

TRANSPORT FOR LONDON

BOARD MEETING – OPEN SESSION TO BE HELD ON WEDNESDAY 27 JUNE 2007 AT 1000 HOURS IN COMMITTEE ROOMS 4 & 5 CITY HALL, THE QUEEN'S WALK, LONDON SE1 2AA

AGENDA

A Meeting of the Board will be held to deal with the following business:

1. Apologies for Absence
2. Minutes of the Previous Meeting held on 30 May 2007
3. Matters Arising from the Minutes

Business Items

Sponsor

- | | |
|--|-----------------------------------|
| 4. The Commissioner's Report | Peter Hendy, Commissioner |
| 5. Annual Report and Accounts | Steve Allen, MD Finance |
| 6. Victoria Station Upgrade | Tim O'Toole, MD LUL |
| 7. Archway Station Upgrade | Tim O'Toole, MD LUL |
| 8. Door to Door Transport
(Withdrawn - oral report given) | David Brown, MD Surface Transport |
| 9. Taxi and Private Hire Vehicle
Licensing Inspections | David Brown, MD Surface Transport |
| 10. Taxi and Private Hire Vehicle
Licensing Fees | David Brown, MD Surface Transport |
| 11. Best Value Performance Plan | Steve Allen, MD Finance |

Items for Noting

- | | |
|--|--------------------------------|
| 12. Direction in relation to Bus Fares | Howard Carter, General Counsel |
|--|--------------------------------|

13. Report from the Finance Committee

Sir Mike Hodgkinson, Chair of the
Committee

14. Report from the Audit Committee

Judith Hunt, Chair of the Committee

15. Any Other Business

Date of next meeting: 19 September 2007

TRANSPORT FOR LONDON

MEETING OF MEMBERS OF THE BOARD – OPEN SESSION

MINUTES of the Board Meeting held in Committee Rooms 4-5, City Hall, The Queen's Walk, London, SE1 2AA at 10.00 am on Wednesday, 30 May 2007

Present:	Ken Livingstone Dave Wetzel Honor Chapman Christopher Garnett Kirsten Hearn Paul Moore Sir Gulam Noon Patrick O'Keeffe Dr Rana Roy Dabinderjit Singh Sidhu Tony West	Chair (33/05/07 – 41/05/07) In the Chair (29/05/07 – 33/05/07)
In attendance:	Peter Anderson Lord Toby Harris Bryan Heiser Shiria Khatun Murziline Parchment	(30/05/07 – 41/05/07)
	Steve Allen Maria Antoniou David Brown Ian Brown Howard Carter Stephen Critchley Michèle Dix Peter Hendy Ellen Howard Nigel Marson Tim O'Toole Jeff Pipe Sam Richards Howard Smith Valerie Todd Jeroen Weimar	MD Finance Director, Group HR Managing Director, Surface Transport Managing Director, London Rail General Counsel Chief Finance Officer MD Planning Commissioner Director of Corporate Governance MD Marketing & Communications Managing Director, London Underground Corporate Governance Adviser Commissioner's Chief of Staff Chief Operating Officer, London Rail MD Group Services Director, TPED (29/05/07 – 35/05/07)
	Horatio Chishimba Kirsten Branks	TfL Secretariat TfL Secretariat

29/05/07 **Apologies for Absence**

Apologies for absence were received from Judith Hunt, Sir Mike Hodgkinson, Stephen Glaister, Lynn Sloman and Eva Lindholm.

Declaration of Interests

No interests were declared.

30/05/07 Minutes of the Previous Meeting held on 28 March 2007

The minutes of the previous meeting were **approved** and signed by the Chair as a correct record, **subject to** amendments being made to the following:

To add Valerie Todd, MD Group Services to the list of attendees;

17/03/07: Cab Design on Overground Rolling Stock: First sentence to read – “Tony West asked about the cab design process for this new rolling stock.”

17/03/07: Powered Two Wheeler Casualties in Greater London: Minute to read – “Dave Wetzel informed the Board that although there was considerable reduction in road casualties overall, there was still a long way to go in respect of powered two wheelers and observed that expenditure was fully justified.”

27/03/07: Update on Sustainability and Climate Change: Second sentence in third paragraph under sub-heading ‘Freight’ to read – “He was especially pleased to note that the document also focused on co-benefits, (economic and social benefits in addition to CO2 reduction), and invited businesses to participate.

31/05/07 Matters Arising

There were no other matters arising from the minutes of the previous meeting. The Board **noted** the table setting out the current status for each of the actions.

32/05/07 The Commissioner’s Report

The Commissioner introduced his report and highlighted key issues and developments since he issued his report.

Blackwall Tunnel – Cessation of tidal flow arrangements on 18 April 2007: The Commissioner said that the Mayor had asked TfL to see whether it would be possible to erect a barrier to separate the two lanes of alternate flowing traffic in the Blackwall Tunnel. The Commissioner confirmed that an engineering solution is not possible.

He also informed the Board that there is some speculation about future arrangements for the Rotherhithe Tunnel which has traffic flow in both directions. Rotherhithe Tunnel is different, in that it is much smaller, is not used by heavy goods vehicles and is subject to a 20mph speed limit. However, David Brown and his team were continuing to keep the matter under review as safety issues were paramount.

Increase in Cycling: The Commissioner advised that the TV Cycling campaign, on a DVD tabled by Nigel Marson, captures in a new way the message TfL

wants to give to Londoners on the benefits of cycling.

FA Cup Final at Wembley Stadium: The Commissioner informed the Board that the transport arrangements had run smoothly and effectively. This demonstrated the success of the re-building of Wembley Park Station, but also that the operational arrangements put in place by LU and Surface Transport for the FA Cup Final were appropriate.

Crossrail: The Commissioner drew to the attention of the Board the paragraph in his report on Crossrail. TfL is engaged in a great deal of activity on the possible funding and management of the project.

Cash Fares: The Board noted that cash use on buses and the Underground was further reduced.

Free Oyster cards: The Commissioner confirmed that TfL had issued the 100,000 free Oyster cards offered to customers in a recent campaign. An analysis of the campaign would be reported at a future meeting.

Action: Nigel Marson

Free Travel for Under 11s on London Underground: The Commissioner told the Board of the successful introduction of free travel on London Underground from 1 April for children aged under 11.

Senior TfL Appointments: The Commissioner informed the Board of the appointment of Michèle Dix and Malcolm Murray-Clark as Managing Director of Planning on a job share basis. Malcolm and Michèle had previously made a great success of a job share arrangement as Directors of Congestion Charging.

Metronet: The Commissioner informed the Board that there was nothing additional to report on Metronet other than that Metronet's recent publicity offensive did not seem to improve the public or media perception of them. TfL's position remains that there should be an Extraordinary Review. While this decision had been reached reluctantly it was necessary due to Metronet's failure to fully disclose information that TfL needs in order to understand Metronet's finances and projected cost overruns.

Climate Change: The Commissioner informed the Board that the Mayor had been in New York for meetings on climate change with 40 city leaders arising from proposals from the Clinton Foundation. TfL would be taking forward a number of actions from this meeting. The Commissioner had also met with chief executive officers of the major European transport organisations and agreed with them that climate change would be put at the top of their collective agenda. There were real opportunities to draw on the expertise across these organisations to develop proposals that would make a significant difference to CO2 emissions.

Discussions of the Commissioner's Report:

Board Members noted that it was difficult for TfL to get positive media coverage despite its proactive media strategy. In addition, TfL did not always receive appropriate acknowledgement of its role in funding facilities such as the cycle

parking at 14 stations on South West Trains.

The Commissioner told the Board that it is difficult to get the media interested in good news. However, TfL had received a lot of positive press coverage in relation to the particular cycle parking initiative. Nigel Marson also confirmed that TfL was examining improvements that it has made throughout London from a marketing and branding perspective and conducting a 'legacy branding' exercise stating that that improvement had been made as a result of investment by TfL.

Board Members and Advisers discussed the quality of accessible bus stops in Paris and elsewhere in the UK such as in Plymouth. It was noted that good bus stop design was essential to achieving modal shift. The Commissioner noted that the accessibility standard of bus stops in Paris varied. The standard in London is more consistent and the bus network larger. David Brown informed the Board that a survey of 18,000 bus stops for accessibility was being undertaken. The Commissioner advised that a paper on bus stop design and TfL's programme in relation to bus stops would be presented to the Surface Advisory Panel.

Action: David Brown

London Overground: Bryan Heiser told the Board that he and Ann Bates, from the Independent Disability Advisory Group, had visited Derby to look at the new rolling stock for London Overground and were delighted with the rolling stock, not only in terms of accessibility but also appearance.

London Travel Demand Survey: The Commissioner informed the Board that an annual document is produced on travel statistics which should be made available to Board members. This would also be considered by the Strategic Planning Advisory Panel. A request was made for information to also be presented in terms of passenger and vehicle kilometre by mode.

Action: Michèle Dix

London Plan – alterations to the Plan to be considered at an Examination In Public: Murziline Parchment requested a copy of the position papers that have been produced by TfL in relation to freight and aviation.

Action: Michèle Dix

Thames Gateway Prioritisation: Board Members congratulated the Commissioner for raising the transport implications of new development in less well served parts of the Thames Gateway with the LDA and GLA. It was important that decisions on these developments took transport demand into account.

Late Running of London Underground – Heathrow Airport: Tim O'Toole explained that discussions about the implementation of the late running of trains were occurring. If it is implemented there would be a reduction in service on Saturday morning which was a concern of both BA and BAA. LU is looking at the possibility of operating a slightly earlier train to Heathrow and this would be supplemented with a bus service to ensure that there was adequate transport provision. However, this would be the inevitable consequence of running a later

service on Friday and Saturday. After consultation, the Mayor had modified his original plan so that there would not be a reduction in service on Sunday morning as this would give rise to real difficulty to those people who needed to use the service.

The Board **noted** the Commissioner's report.

33/05/07 Operational, Financial and Investment Programme Reports

Steve Allen introduced the report which informed the Board of TfL's performance over the fourth quarter of 2006/07; the operational MDs would each speak on their area of management.

Steve Allen said that 2006/07 was a year of significant growth in levels of patronage with passenger journey numbers of just under 3 billion.

London Underground

Tim O'Toole said that LU had carried over 1 billion passengers for the first time. This was facilitated by a switch from ordinary tickets to Pay As You Go. However, while LU operated at a record level during the year this had had implications for the reliability of the service.

During the period, major injuries to customers rose, reflecting in part the increase in traffic across all of the Underground. However, the probability of suffering such an injury remains very low. There were 10 customer fatalities of which eight were trespassers and the remaining two were caused by inappropriate behaviour on platforms.

LU continues to see an improvement in mean time between failures of rolling stock, however track and signal failures increased from the previous year. The Victoria line under-performed in all three categories.

Staff numbers had increased in the final quarter due to the intake of trainee Customer Service Assistants but remained within budget overall. There had also been a 1.3 percent increase in female staff. In December 2006, LU became the first public sector body to be selected to join the Ethical Trading Initiative.

Surface Transport

David Brown said that bus passenger journeys increased by 3.6 per cent to almost 1.9bn passenger journeys. He expected that figure to continue to increase. Bus operated kilometres was the highest since the mid-1960s and the operated mileage before allowing for traffic is the best ever. Reliability has been maintained and excess waiting time remained at 1.1 minutes which means that it had been better than target for 16 consecutive quarters.

The percentage of roads in need of major repair was down 5.7 percent against a target of 6 percent.

As the Mayor had announced recently, there has been an 83 percent increase in cycling since 2001 and funding for cycling has been increased from £5.5m in 2002 to £24m in 2006/7. Road safety targets for 2010 had been met already

and more stringent targets were being applied.

Further improvements in emissions from taxis and the bus fleet have been made. The world's first hybrid double deck vehicle was launched. The Western Extension to the Congestion Charging zone was launched on 19 February and traffic impacts are in line with expectations. The Coulsdon relief road opened to traffic in December 2006.

Over 200 directors and managers in Surface Transport had attended 'Way Forward' workshops launching Surface Transport's Strategic Goals and Leadership Framework. During 2006/07 46 graduates joined Surface Transport's graduate recruitment scheme. He concluded his report by adding that staff turnover was 9.7 percent against a target of 10.3 percent.

London Rail

Ian Brown informed the Board that passenger numbers on the DLR were still growing, with 61 million passengers carried during the period, the highest number ever. The first full year of performance of the DLR to City Airport had gone well and it now carries 100,000 passengers a week. An airport commissioned survey showed that DLR had gained a 50 percent modal share of travellers to the airport. The difficult task for DLR as it grows will be to keep up the on-time performance which has been its highest at 97.8 percent. Scheduled mileage operated was 99.1 percent and customer satisfaction has levelled off at 96.6 percent.

Ian Brown said that passengers will get real benefits from TfL's involvement in the Overground after 11 November. He stressed the following points:

- Oyster PAYG across the whole system;
- 11 stations with barriers;
- a fully staffed railway; and,
- a secure railway with CCTV being phased-in.

In addition, key improvements would include:

- more trains with increased frequency per hour;
- 44 new trains;
- a station refurbishment programme; and,
- track and signalling upgrades.

Ian Brown also confirmed that TfL would require the franchisee to have staff based at all stations, supported by added security staff on the Gospel Oak – Barking line. A request from the Mayor had been included in the Overground Concession that staff, with security support, must be available at the stations at all times, during service hours.

The Chair said that TfL should look at erecting buildings at the stations to accommodate staff. Ian Brown confirmed that there is a programme to install waiting rooms and facilities for staff at stations.

The enabling works on the East London Line were going well without people being too inconvenienced by the works.

All but one of the contracts for the Olympics involving DLR including extensions and upgrades has been completed.

Financial

Steve Allen concluded the presentation by giving financial highlights for 2006/07.

Kirsten Hearn informed the Board that she was participating in the mentoring programme and encouraged Board Members and senior officers to volunteer as mentors. Information on the mentoring scheme would be circulated to Board Members and Advisers.

Action: Howard Carter

A request was made for a record of year-on-year performance on local air quality as this will be critical in linking up with the Climate Change Action Plan.

Action: Michèle Dix

Dr Rana Roy informed the Board that at the Panels meetings earlier that month, he had raised an issue regarding the figures quoted in reports on the percentage of Black and Minority Ethnic staff at TfL. He asked for an explanation of the difference between these figures and those in the TfL Business Plan 2005/06 – 2009/10. Valerie Todd said that the matter will be addressed through the Corporate and Equalities Advisory Panel.

Action: Valerie Todd

Valerie Todd informed the Board that TfL conducted an annual review of pay. The review checks that the historical issues around gender differences have been and continue to be addressed. Valerie Todd confirmed that TfL did not have a pay-gap between men and women.

David Brown confirmed that in Surface Transport the fatality numbers did not include bus staff because a majority of staff worked with operators not TfL itself. David Brown undertook to provide Patrick O’Keeffe with major injury figures.

Action: David Brown

Tim O’Toole agreed to add figures on workforce safety into the London Underground report.

Action: Tim O’Toole

Board members questioned whether it was realistic to indicate that customer satisfaction could be raised to the level proposed given the impacts of implementing TfL’s infrastructure programme and passenger numbers. Tim O’Toole stated that LU was considering making an adjustment to reflect the impact of the increasing numbers of passengers being carried.

The Board **noted** TfL’s:

1. Operational and financial performance over the fourth quarter, 2006/07;
and
2. Progress on the Investment Programme over the fourth quarter, 2006/07.

Update on Sustainable Procurement

Valerie Todd introduced the report which gave an update on progress in implementing the GLA Group's Sustainable Procurement Policy.

The Chair asked whether all the bus companies were making progress in implementing the London Living Wage in their cleaning contracts. Valerie Todd confirmed that the report reflected those companies to whom TfL had recently let contracts. David Brown said that the bus contracts would address the issue over the next two years.

Board Members asked about TfL's Fair Trading initiatives. Valerie Todd confirmed that TfL was currently focussing on its main suppliers and sub-contractors.

The Commissioner told the Board that the Ethical Trading Initiative included the procurement by LU of TfL's uniforms. The Commissioner added that, in future, he would like to turn the report to the Board from one that specified particular "successful" contracts to one that identified the exceptions and particular issues that needed to be addressed.

Board Members raised the issue of employers facilitating staff being members of Trade Unions and TfL auditing its contractors to ensure compliance with these principles. The Commissioner agreed that the next update would deal with these points.

Action: Valerie Todd

Valerie Todd confirmed that discussions with suppliers on sustainable procurement had been very positive. However, it was important to ensure that the cost of applying sustainable procurement principles by TfL's contractors is not transferred back to TfL as an increased cost. The Commissioner added that one of the benefits of applying these principles is that there would be an improvement in recruitment and staff turnover which would result in real savings to the contractors and hence minimise the cost to TfL.

The Chair informed the Board that Valerie Todd was now taking a lead role across the GLA Group on convergence issues and particularly driving forward the sustainable procurement agenda.

The Chair informed the Board that he had recently returned from the C40 conference in New York where an initiative had been launched between major cities to retro-fit public buildings to be more energy efficient. A number of banks had agreed to make loans available and some of the largest energy service companies in the world have agreed to reduce their prices in order to achieve this. There are 900 buildings in the GLA group, excluding LU. The Chair said that the Commissioner had agreed to find someone to lead this project on behalf of the Group. The project would have a project manager, serving the whole of the GLA but based in TfL.

The Board **noted** the contents of the report.

David Brown introduced the report which sought Board approval for the publication and implementation of TfL's 2007/08 Community Safety Plan.

He advised that this document was the outcome of the consultation on TfL's draft Crime and Disorder strategy and outlined the Plan's four strategic priorities to address safety and security on the transport system. He told the Board that the Plan will be updated annually.

Kirsten Hearn asked whether TfL could emphasise the contribution to community safety of full accessibility to transport by customers. The more TfL can enable people to travel independently the less the number of opportunistic crimes will be committed.

Action: David Brown

Board Members welcomed the report and said that it needed to be recognised that, although London's transport system is in fact very safe, there can be a perception that it is not safe. It was suggested that reordering the priorities may assist. The gap between crime and the fear of crime is large and more analysis is required along with strategies to address it. This should be considered in future versions of the Plan.

The Commissioner said that TfL would look at providing further context because the selective use of statistics could indicate, erroneously, a significant increase in crime. In terms of the total level of crime, particularly on the bus network, crime has dropped by four percent as a whole. There has been an increased level of crime committed by under-16 year olds; however that should be seen in the context of an increase in the ridership among that age group.

The Commissioner said that the issue of the perception of crime would be addressed separately and brought to a future Board meeting.

Action: David Brown

The Workplace Violence Unit was commended. Patrick O'Keeffe advised TfL to take the opportunity to provide support to the employees who have been assaulted. TfL should perhaps consider including information in the report on the back-up support it provides to employees.

Action: David Brown

Street Crime and Passenger levels: Jeroen Weimar informed the Board that TfL was introducing the 11-15 Oyster card. TfL would also carry out a schools outreach programme to be rolled out from the summer until September 2008. The outreach programme would go to every school to explain to children of 11 and 12 the use of the Oyster card as well as talk to them about security. He added that the Plan was also a way for TfL to engage with other agencies like local authorities and the Youth Justice Board. On the Overground, Jeroen Weimar confirmed that TfL had introduced over 70 officers from BTP on the North London Line as part of the transition to London Overground in November 2007. Over the last 12 months, the presence of these officers has had a significant impact and this will be built upon from November.

The Board **approved** the publication and implementation of TfL's Community Safety Plan 2007/08 and **agreed** that the Board would receive a report in May 2008 on progress in implementing the Plan.

Action: David Brown

36/05/07 **Venezuela: Energy Funding and Co-operation Agreement**

Peter Hendy introduced the paper which summarised the Energy Funding and Co-operation Agreement between the Venezuelan state oil company's European subsidiary (Petroleos de Venezuela) PDV Europa B.V., the Greater London Authority and Transport for London signed on 20 February 2007.

The Board **noted** the contents of the report.

37/05/07 **Transport Trading Limited – Appointment**

Howard Carter introduced the paper which sought Board approval to appoint Steve Allen as a Director of Transport Trading Limited.

The Board **approved** the appointment of Steve Allen as a Director of Transport Trading Limited.

38/05/07 **Report from the Finance Committee**

Steve Allen introduced the report which informed the Board of matters discussed at the Finance Committee meeting held on 16 May 2007.

The Board **noted** the contents of the report.

39/05/07 **Mayoral Delegation and Direction: re Cross GLA Group Sustainable Procurement and Supply Diversity Implementation Support Team**

Howard Carter introduced the paper which informed the Board of a Direction and Delegation from the Mayor to TfL regarding the establishment and operation of the Cross-GLA Sustainable Procurement and Supplier Diversity Implementation Support Team.

The Board **noted** the receipt of the Delegation and Direction from the Mayor.

40/05/07 **Mayoral Direction: Discounted Bus and Tram Fares for London Residents who receive Income Support**

Howard Carter introduced the paper which informed the Board of a Direction from the Mayor to TfL regarding the level and structure of fares to be charged for public passenger transport services. The Direction implements discounted bus and tram fares for London residents who receive Income Support.

The Board **noted** the receipt of the Direction from the Mayor.

41/05/07 Any Other Business

There being no further business the meeting closed.

Signed by the Chair: _____

Date: _____

TRANSPORT FOR LONDON

BOARD

SUBJECT: THE COMMISSIONER'S REPORT

MEETING DATE: 27 JUNE 2007

1. PURPOSE

This report provides an overview of major issues and developments since the 30 May Board meeting and updates the Board on significant projects and initiatives.

2. MODAL OPERATIONS

2.1 Surface Transport

Bus Passenger Journeys

Estimated passenger journeys for period 1 show an 11.6% increase compared to last year. This is partly due to major changes in the way that passenger journeys are calculated. Previously journeys have been estimated from ticket sales and, where necessary, passenger usage (based on survey data). These estimates are now based on Oyster validations where available (uplifted for non-validation), non-Oyster ticketing and the inclusion of additional categories (TfL staff, under 5s and Police Officers). The 2006/07 passenger journeys will be recalculated for the next Commissioner's report to the Board using an equivalent method to allow year-on-year comparisons to be made on a like-for-like basis.

Bus Driver BTEC Training

Figures for the 2006/07 year end show that 88% of all bus drivers qualified following Business and Technical Education Council (BTEC) training. This is consistent with the network average annual rate of bus driver turnover of 15% and the contractual requirement for all drivers to complete their BTEC within their first year. BTEC training focuses on standards of driving, customer care, disability/equality awareness and service control. Driver and service controller BTECs are now embedded into initial training of new staff and will continue. By the end of this year, all garage support staff should also be BTEC qualified. Good progress is being made towards achieving this target, with a number of operators already having trained all garage staff.

Safer Transport Teams

Deployment of Safer Transport Teams continues with the introduction of the North East Safer Transport Teams completed on target at the end of April. TfL has funded the provision of 375 Police Community Support Officers formed into dedicated

borough based Safer Transport Teams. These are deployed alongside Metropolitan Police Service Safer Neighbourhood Teams to deal with problems on all modes of public transport. With this deployment, teams are now in place in the South East and North East outer London boroughs. The North West and South West roll out should be completed by the end of July.

Highway Trainee Technicians

The first Directorate of Road Network Management Civil Engineering Trainee Technician, Yasaar Masood, aged 16, started in the Directorate of Road Network Management on 23 May 2007. Recruitment of at least three more technicians is in hand, with a view to the initiative being rolled out to other Surface Transport Directorates shortly. Work is also underway in collaboration with London Underground, the Institution of Civil Engineers (London) and the Learning and Skills Council to seek external funding to fund additional posts as part of this initiative.

Bus Stop Arrangements Consultation

Consultation material on London's bus stopping arrangements was sent to over 600 stakeholders. Views are being sought on changes to the current compulsory and request stop operation, how to make Hail & Ride services more accessible, and how best TfL should notify occupiers of frontages when making changes to bus stop infrastructure. Consultation closes on 20 July 2007.

2.2 London Underground

Customer service and performance

The new financial year has got off to a good start with excess journey time averaging 7.16 minutes over the first two periods compared with last year's average of 8.06 minutes, and the percentage of schedule operated averaging 95.9 per cent, well ahead of target. Of note has been the performance of the Northern line which has achieved its best percentage of schedule for almost two years. Another factor is employee attendance which has consistently exceeded 96 per cent, the first time this has been achieved for at least ten years.

Wembley Park and Wembley Station

The first concert to be held at the new Wembley Stadium took place in the evening of Saturday 9 June when George Michael performed in front of an audience of 75,000 fans. Loadings on the Metropolitan and Jubilee lines were heavy but there were no reported problems and all returning traffic from the concert had cleared before midnight.

PPP Contract Reviews

Metronet has indicated that it expects its two Infracos to incur additional costs in excess of £750 million over the current 7½-year review period, and is consequently expected to pursue an Extraordinary Review. This review would be conducted by the PPP Arbiter who would determine who should bear the additional costs.

In order to strengthen London Underground's ability to respond to any Extraordinary Review and to meet the challenges posed by the Periodic Review in 2010, Sarah Atkins, currently LU Director of Legal, has been appointed to the position of Director of Reviews and Legal, with overall responsibility for Contract Reviews. She will take

over a core team currently preparing for Contract Reviews, the role of the team being to prepare submissions to the Arbiter and to ensure there is a consistent analytical approach across Reviews.

2.3 London Rail

DLR Performance

Overall service performance remains at the top of the UK rail industry with all major targets exceeded. The most recent customer satisfaction survey shows record passenger scores for both passenger security and service information. For the last recorded period, DLR obtained a 98.01% service reliability.

National Rail in London

TfL London Rail and TfL Fares and Ticketing are considering how best to integrate Overground fares into the TfL fares structure from 11 November, the start of the London Rail Concession. An Oyster promotional fare is proposed, designed to get passengers used to Oyster Pay As You Go on a National Rail service that previously did not accept this form of payment prior to 11 November.

In order to inform DfT's High Level Output Statement on future rail capacity requirements, TfL, Network Rail and the DfT have jointly undertaken research into the scope for 'peak pricing' to encourage people to move away from the 'peak of the peak'. It was found that significant changes in fares structures and differentials would be needed to spread demand, combined with 'shoulder peak' capacity enhancements.

In relation to step-free access, TfL has identified its next ten preferred National Rail stations for the third tranche of DfT-funded works to create step-free access between street and station. These are Ilford, Bromley South, Ealing Broadway, Edmonton Green, Dalston Kingsland, West Croydon, Worcester Park, Gospel Oak, Hampstead Heath and Camden Road.

Network Rail has agreed to take forward the development and funding of Hackney Interchange. This is a TfL London Rail project which will link Hackney Downs and Hackney Central stations within a secure area and will avoid the need for passengers to interchange via local streets. The scheme will improve access to London Overground services from the Lee Valley (Chingford, Cheshunt, Enfield Town), thus improving access to the Olympic site at Stratford, and has a very good business case. It is to be funded through the Network Rail Discretionary Fund and will be delivered in time for the Olympics.

In relation to the development of rail freight facilities, the Planning Inquiry into the proposed Howbury Park freight interchange (near Slade Green), at which TfL provided evidence in support of the proposal, has now closed. A decision is expected in the New Year. At the site of the proposed Barking International Rail Freight Interchange at Ripple Lane, Barking, (which would have a direct link to the 'High Speed 1' route to and from the Channel Tunnel), the Roadways Container Logistics site is being sold to a developer. TfL intends to work with the developer to take forward its concept for a larger scale facility. TfL is continuing to liaise with the

relevant local planning authorities in order that their planning frameworks recognise this as a strategic requirement.

London Overground

The placing of the 7-year concession contract to operate London Overground services is progressing. The TfL Board meeting held 30 May approved the necessary finance to award and delegated the decision to the commissioner following further negotiations with Hong Kong MTR / Laing and Govia (GoAhead and Keolis). The Mayor announced the successful bid by MTR / Laing on 19 June.

3. MAJOR PROJECTS AND INITIATIVES

DLR Projects

The second bore of the Woolwich Arsenal extension tunnel is progressing well with the Tunnel Boring Machine having almost reached the half way point under the river by early June. The station works in Woolwich itself are well advanced and despite the extensive disruption to Woolwich town centre, local stakeholder support is strong and local residents' complaints have been negligible.

Six months into the Network Rail works package for the Stratford International extension, the contractor Skanska / Grant Rail is making encouraging progress. A number of utility and service diversions are currently underway and the piling for the Olympic bridge works, which DLR is undertaking under agreement with the ODA, are now largely complete. Phase 2 of the project, the main DLR works between Stratford International and Canning Town, is expected to be let during June so that the opening date of 1 July 2010 can be satisfactorily maintained.

Taylor Woodrow, as the recently appointed 3 car contractor, is now mobilising on the railway with site establishment underway at Canary Wharf and Canning Town.

Phase 1 of the new Will Allsop designed station on the north route at Stratford opened on 18 June with the full station opening programmed for late August 2007.

East London Railway Extension

The Main Works Contract to construct the extended East London Railway is well underway with detailed design and approval work progressing. The first four key implementation milestones which were set by the East London Line project, have all been achieved by the contractor Balfour Beatty / Carillon; start of work at Shoreditch, Dalston and Bishopsgate and cablework at New Cross Gate. The programme is on schedule for public opening in June 2010.

Stratford Regional Station Upgrade

The transition of programme management from TfL to the Olympic Delivery Authority (ODA) is progressing towards a projected completion date of the end of June 2007. The Guide to Railway Investment Projects (GRIP) stage 5 review has been completed and passed. Achieving GRIP5 by TfL is the most significant milestone for the project as it marks the transition from a scheme in development to one that is fit for construction. It is the most difficult of all project stages as it requires all stakeholders to give their final sanction, signifying the final commitment to implement the scheme.

4. CORPORATE ACTIVITIES

Stansted Surface Access Strategy Response

TfL submitted a response to the Stansted Generation 2 surface access proposals. These proposals relate to the addition of a second runway at Stansted and arose out of the Government's 2003 White Paper – *The Future of Air Transport* – which set out a framework for the development of airport capacity. BAA has stated that a planning application for the 2nd runway ('G2') will be submitted in Summer 2007, hence this was an important opportunity to provide TfL's input to the surface access strategy. On 30 May, a Public Inquiry will begin regarding Uttlesford council's refusal of BAA's 'G1' application (expansion up to existing limits of 1 runway). However the G2 application can go ahead separately from the G1 application. The Mayor currently does not support any airport expansion. In TfL's response, the main issue highlighted was the substantial increase in surface trips and consequential impacts on the transport network and emissions. The Stansted Generation 2 expansion proposal will mean an increase of more than 40m passengers on top of the current 19m passengers per annum needing surface access to get to or from the airport by 2030. It will have a significant impact on the network and emissions as about 40% of these trips either start or end in London. This will create the need for additional capacity requirements, particularly on national rail and requires consideration of how to balance the needs of all passengers using these corridors.

Planning White Paper

The implications of the Government's Planning White Paper are being investigated including opportunities for improving planning for sustainable travel. A report from TfL will be produced for discussion with the GLA before submitting a final response.

Borough Local Implementation Plans (LIPS)

28 boroughs have finalised and submitted their LIPs with 22 approved to date. The remaining five are due to submit shortly.

LIP Funding

Annual applications from boroughs and sub-regional partnerships for TfL LIP Funding are due this month for schemes to be delivered in 2008/09. They will be based on boroughs' final LIPs. For 2006/07, boroughs delivered nearly 100% of their budgeted programmes. This maintains the excellent delivery record of 95% or more maintained for several years.

TfL Event for London Councils

Borough Partnerships hosted an event for London Councils Transport and Environment Committee (TEC) Members in May, providing an opportunity to meet senior staff from Surface Transport, London Underground, London Rail, Group Property and Borough Partnerships. The event was well received.

4.2 Group Services

Diversity and Equality

The Managing Diversity and Competency Programme (MDCP) in its first phase has now engaged with 400 duty managers from London Underground. Initial evaluation would indicate that the programme is having a positive impact on behaviour within the workplace. The programme is developing greater awareness in understanding others, creating a greater understanding of social identity and builds confidence to manage potential workplace harassment issues.

TfL held a highly successful commemoration event for the Bicentenary of the Abolition of Slavery on 29 May 2007. The event was organised in collaboration with the BAME staff network group.

On 30 June 2007, the Lesbian, Gay, Bisexual and Transgendered (LGBT) Staff Network group will be participating in the annual London Pride event, and are currently organising a bus as part of the parade.

Property

The delivery of phase one of the office accommodation strategy continues on programme. The two new “hub” locations are established as Palestra in Blackfriars Road (occupation 2008) and the Shard at London Bridge (occupation 2011), both in the LB of Southwark. The preferred option for the consolidated back-office site has been selected, and commercial negotiations are ongoing. This trio of new buildings will modernize the majority of TfL’s office portfolio for over 5,000 staff, and will deliver not only the stated strategic objectives of better workspace and lower cost, but also demonstrate TfL’s commitment to sustainability. These new office spaces are due to achieve ‘BREEAM excellent’ (the industry benchmark), incorporate decentralised energy, and implement a variety of further measures to promote both modal shift and emerging technology for emissions reductions (such as the fuel cell technology at Palestra).

Collective Bargaining

The TfL Framework for Consultation and Collective Bargaining was signed on 31 May 2007. The framework will lead to a greater understanding of future organisational requirements by union representatives and employees which will facilitate the implementation of change. Additionally it will assist in the timely resolution of concerns that are raised. A launch event was well attended by union representatives as well as management from TfL.

4.3 Fares & Ticketing

Bus Fares Reduction

On 18 June the Mayor announced a reduction in Oyster Pay-as-you-go fares on buses and trams from £1 to 90p and a reduction in the cost of weekly bus passes from £1.40 to £1.30. The cost of these proposals is estimated as £36m over a full financial year, which is broadly equivalent to the revenue surplus for 2006/07. The fares proposals will come into effect on 30 September 2007.

Expansion of the Oyster Retail Network (Pearl)

TfL agreed a variation to the Prestige PFI contract to enable the Oyster retail network to roughly double in size. This deal will result in the creation of a new card reader called the 'Pearl' that will be integrated with other sales devices to create a new retail terminal. The number of agents will expand from the current 2,200 to 4,000 of which 3,500 will be in postcode areas specified by TfL. The project is due for completion in mid-2008 and results overall in cost savings for TfL due to the elimination of high commission products. The Pearl device will also be integrated with third party manufactured ticket machines such as those being installed later this year on London Overground.

4.4 Finance

Community Infrastructure Fund (CIF)

The DfT have confirmed a payment of £1.25m as an initial CIF grant contribution to the Dalston Junction Interchange and Langdon Park – a new DLR station proposed between All Saints and Devons Road stations. The DfT have also been invited to agree the phasing of the £34m funding for the DLR 3-car upgrade, Greenwich Waterfront Transit and East London Transit.

Positive Feedback on Financial Accounting function

Feedback from KPMG, TfL's external auditors, on the performance of the recently restructured Financial Accounting department was positive. The year end completion meetings noted no unadjusted items and recognised an improvement in the overall performance of processes within the Financial Shared Services Centre's Financial Accounting function.

Actuarial Valuation of Pension Fund

Work to finalise the actuarial valuation of the TfL Pension Fund has continued with a view to finalising it by the statutory deadline of 30 June. This involves further meetings and negotiations involving the Trustees, TfL (as the Principal Employer) and other participating employers in order to seek to resolve any outstanding issues.

4.5 Travel Demand Management

School Travel Planning (STP)

543 School Travel Plans (STPs) were completed and approved in 2006/07, bringing the total number completed to date to 1,627 (53.4% of all schools). The first annual STP Accreditation Scheme awards ceremony took place at City Hall on 14 June, with Jenny Jones presenting the awards. These awards acknowledge schools that 'go the extra green mile' in producing, implementing and reviewing their STPs.

Workplace Travel Planning (WTP)

The NHS Travel Plan Steering Group, which was created through TfL support, hosted a networking conference on 24 May. There are now 30 NHS sites developing WTPs (43% of London Trusts) in the Capital.

Personal Travel Planning (PTP)

Two geographical areas are benefiting from this year's PTP programme, the London Boroughs of Sutton and Camden. The Smarter Travel Sutton programme, targeting

70,000 households, launched in April 2007. The Camden scheme, targeting 30,000 households, was launched on 20 June.

Olympic Games Demand Management

TfL is developing an integrated TDM strategy to reduce background traffic in the run up to the Games. The aim is to free road space for the Games related traffic and also leave a legacy of a significant uplift in the levels of walking, cycling and public transport usage across the boroughs of east London. Meetings have been held with LOCOG and the ODA to agree the scope of this project, with options for an intensive TDM programme, similar to the Smarter Travel Sutton approach, being developed.

4.6 Marketing and Communications

Safety and Security

The latest Teens road safety research has highlighted the increased effectiveness of the new TfL TV and poster campaign: overall prompted recognition has risen to 89% from 79% in 2005; spontaneous recognition has risen to 82% from 78% in 2006; prompted recall of the new TV advertisements is 77% on a far lower spend than that of the previous advertisement (66%); the highest recognition of TV was amongst Black Asian Minority Ethnic (BAME) boys (the most vulnerable group) with 81% compared to the previous two TV advertisements which scored 63% and 57% respectively; poster recall increased amongst BAME boys to 68% from 57%; and spontaneous message recall to 'be careful on the roads' has increased to 56%.

Best Central Government Website

The TfL website won the Best Central Government Website at the Good Communications Awards 2007. The awards recognise excellence in public sector (local and central government departments) communications. TfL's website was described by judges as "highly interactive, clearly designed and informative. Excellent innovative use of media with mobile and online interactive map traffic alerts, interactive timetable and journey planners". TfL.gov.uk beat the Home Office and Direct Gov to clinch the prize.

Coverage in Local and BAME Media

TfL has had extensive positive coverage in the local and BAME press on a number of issues. The Tube Investment Programme and the cooling the tube announcement were of particular interest to the Turkish and Polish papers. Cycling and the Tour de France have also been picked up by many local papers and BAME outlets. The Mayor's announcement that licensed minicabs will be allowed to stop on red routes received strong positive press coverage with 9 positive pieces across a balance of Black Asian Minority Ethnic (BAME), trade and local media titles. The DLR extra carriage upgrade received good media coverage with 12 positive pieces across both trade press and local press.

5. CORPORATE ISSUES

UITP Helsinki Congress

The Commissioner visited Helsinki for UITP's biennial Congress on 22-24 May. In addition to speaking on "Transport challenges for growing cities", the Commissioner attended meetings of the Major Metropolises Group (MMG) with CEOs of other

European city transport organisations and achieved agreements including taking forward initiatives on climate change and joint positions on the forthcoming Green Paper on Urban Transport.

Report to Assembly Meeting 13 June re Mr Kiley

A Report on the Consultancy Arrangements for Bob Kiley was submitted to the London Assembly and senior officers attended a meeting of the Assembly together with the Mayor to answer questions. The session focused on the retainer nature of the contract, how value for money was judged and the separate arrangements made at the time of Mr Kiley's departure relating to his contract of employment. The Assembly passed a motion concerning the consultancy arrangements.

Commissioner's visit to Caracas

The Commissioner will be visiting Caracas between 20 and 25 June as part of the Bus and Tram fares support scheme. After the Commissioner's fact finding visit TfL will confirm with Venezuela the areas where technical advice will be agreed.

Peter Hendy
Commissioner of Transport
Transport for London
June 2007

TRANSPORT FOR LONDON

BOARD

SUBJECT: TFL'S ANNUAL REPORT AND ACCOUNTS 2006/07

MEETING DATE: 27 JUNE 2007

1. PURPOSE

- 1.1 The purpose of this report is to seek the Board's approval for the publication of TfL's 2006/07 Annual Report.

2. BACKGROUND AND OBJECTIVES

- 2.1 TfL is legally required under section 161 of the Greater London Authority Act 1999 to produce a report on its achievements and the performance of its functions during the year. Approval of the Annual Report is a matter reserved to the Board under TfL's Standing Orders.
- 2.2 The 2006/07 Annual Report will include the final statement of TfL's Accounts. While this is not a legal requirement it is regarded as good practice and will assist key audiences in understanding TfL's financial and operational performance over the year.
- 2.3 This year there will be two separate versions of the report produced
- (1) Version "A" will consist of the front section of the report and will additionally include the full statement of accounts for 2006/07. This version will be 110 pages long. It is intended that this version be sent out to key financial institutions and rating agencies.
 - (2) Version "B" will consist of the front section of the report, and will instead include a financial review – highlighting key financial information. This version will be 60 pages long. It will still include the information that is required under the GLA Act. It is intended that this version be sent out to stakeholders, and other parties not specifically requesting full financial information.

2.4 Both versions, "A" and "B", are clearly labelled and have been provided to the Board.

3. FINANCIAL IMPLICATIONS

3.1 There are no direct financial implications.

4. CRIME AND DISORDER IMPLICATIONS

4.1 There are no direct crime and disorder implications.

5. EQUALITIES AND INCLUSION

5.1 TfL's Annual Report 2006/07 will be made available on request in a variety of languages, Braille, Large Print, Easy read and British Sign Language.

6. SUSTAINABILITY

6.1 The report highlights TfL's key achievements in tackling climate change and its initiatives to improve its environmental impact.

6.2 TfL's Annual Report 2006/07 will be printed on 80% recycled paper to reduce the impact to the environment through its production. A tighter focus on content also means that version B will be approximately 90 pages shorter than last year, which will save resources whilst safeguarding the quality of the information in the report.

7. RECOMMENDATIONS

7.1 The Board is recommended to:

- (1) APPROVE the 2006/07 Annual Report subject to any comments they might have;
- (2) NOTE that the foreword from the Mayor will be added prior to publication;
- (3) DELEGATE authority to the Managing Director of Marketing and Communications for final changes to the Annual Report; and
- (4) APPROVE the Statement of Accounts and to agree that the Chief Finance Officer will make any adjustments arising from the ongoing work prior to the auditors signing their opinion. Should any changes be required to the Statement of Accounts which, in the opinion of the Chief Finance Officer, are material, he will seek the approval of the Board to these changes.

Meeting	TfL Board
Date	27 June 2007
Title	TfL's Annual Report 2006/07

Author	Stephen Webb, Interim Director of Communications	
Sponsor	Nigel Marson, Interim Managing Director of Marketing and Communications	•
For queries please contact	Stephen Webb	Auto 64884

TRANSPORT FOR LONDON**TFL BOARD**

**SUBJECT: LONDON UNDERGROUND
VICTORIA STATION UPGRADE**

MEETING DATE: 27 JUNE 2007

1.0 PURPOSE

- 1.1 To secure Board approval for London Underground Limited (LU) to submit an application for a Transport & Works Act Order (TWAO) in respect of the proposed upgrade of Victoria station.

2.0 BACKGROUND

- 2.1 The Victoria station upgrade is included in the Mayor's Transport Strategy, London Plan and TfL Investment Programme. It is a non-PPP project managed and delivered by LU. It is also included in Westminster City Council's (WCC) Victoria Area Planning Brief, March 2006. The scheme is illustrated in Figure 2, accompanied by a plan of the existing station in Figure 1.
- 2.2 Congestion at Victoria Underground station is severe, resulting in daily peak closures of the station. Passenger numbers are forecast to rise 20% by 2016, worsening the situation. A congestion relief scheme is urgently required and the project to deliver this is known as the Victoria Station Upgrade (VSU). VSU aims to be completed as soon as possible following the PPP Victoria Line Upgrade (VLU) and is needed in order to safeguard the delivery of VLU's benefits by enabling better access, including step-free access, to the improved train service at Victoria.
- 2.3 Victoria is one of the busiest and most-congested multi-modal transport interchanges in London and a principal National Rail gateway. The provision of better access and capacity at the Underground station has been a high priority for LU and TfL for many years as part of a wider aspiration to improve the interchange. The development of the current scheme dates back to mid-2004 when a decision was made by TfL and LU to phase the implementation of transport improvements at Victoria to achieve key transport objectives, by prioritising investment on the most critically-congested areas of the Underground station.

3.0 DESCRIPTION OF THE SCHEME

- 3.1 The VSU proposals provide new Underground station entrances and a subterranean ticket hall at the junction of Bressenden Place and Victoria Street, with escalator and lift access to the north end of the Victoria line platforms. The existing Victoria line ticket hall, to the south, will be enlarged to provide further escalators and lifts to improve access to the Victoria line

platforms. Additional sub-surface capacity will be provided with an additional link between the Victoria and District & Circle (D&C) line platforms and passageways connecting the new south escalators with the new north end of the station and the existing interchange concourse. The station will become double-ended so that capacity, journey time and emergency evacuation are improved. The proposed Victoria station upgrade is illustrated in Figure 2.

- 3.2 Further transport development, such as access improvements to the District & Circle line, will be addressed in due course but these do not form part of the VSU scheme. The means of achieving this will be assessed in the light of progress with the development of the Victoria Transport Interchange (VTI) project. VTI is a commercially-led scheme promoted by Land Securities in consultation with TfL. The VTI proposals include a comprehensive redevelopment of a large area, including the reconstruction of the District & Circle line station. The VTI proposals remain distinct from, but complementary with the VSU scheme. LU is continuing to work with the TfL VTI project and Land Securities to maximise compatibility whilst maintaining an independent scheme and programme towards a TWAO application for VSU.

4.0 CURRENT STATUS

- 4.1 The VSU project has been developed to scheme design (RIBA Stage D) with a recommendation to take forward detailed design development (RIBA Stage E-G) was approved by the Commissioner following the Project Review Group on 18 May 2007.
- 4.2 The development of VSU incorporates a number of associated initiatives to form a comprehensive programme of works. The opportunity has been taken to accommodate the emerging Tunnel Cooling Project infrastructure requirements, absorb the Public Private Partnership Station Modernisation scope, progress asbestos removal works and design the required utility diversions. The on-going project development is being informed by an Independent Engineer Review which has been undertaken by TfL.
- 4.3 With respect to powers to build and operate the new station facility, LU is proceeding with a TWAO application. LU has been advised by our legal representatives that this route is the optimal one taking into consideration the strengths and weaknesses of alternative routes using separate compulsory purchase powers under the GLA Act, alternative means of dealing with the stopping up and diversion of highways and securing planning consent under the Town & Country Planning Act.

5.0 KEY IMPACTS

- 5.1 A summary of the key impacts of the Scheme is given below.

Regeneration

- 5.2 Victoria is a major centre of office and retail employment within Westminster, whilst including substantial residential areas. Victoria is identified in the London Plan as an *Area for Intensification*, with 2,000 new

jobs and 200 new homes. The Victoria Station Upgrade positively contributes to achieving the objectives of growth by providing an expanded Underground station to improve access to the area.

Congestion Relief

- 5.3 The Victoria Station Upgrade will relieve existing congestion, enable faster journey time and interchange between the Victoria and D&C lines, and improve interchange with the National Rail station. VSU positively contributes to the objectives of the London Plan and the Mayor's Transport Strategy (specifically Proposal 4C.9: improving conditions at London's most congested stations, and Proposal 4C.11: creation of a core accessible network).

Equality and Inclusion

- 5.4 An EQIA assessment has been undertaken for the proposed scheme with the result that VSU has a positive EQIA impact. The Victoria Station Upgrade will improve accessibility to the station and the Underground network with the provision of lifts throughout the station, enabling step-free access between street, ticket hall and platform levels.

Environmental Considerations

- 5.5 The introduction of new station structures will have some impact on the local urban environment but through careful design and appropriate mitigation, they have the potential to be seen as a positive impact on the local area. As part of the TWAO application, the proposals will be subject to a full environmental impact assessment and appropriate mitigation.

Sustainability

- 5.6 A sustainability appraisal is being implemented to ensure that LU complies with all relevant policies, industry standards and good practice and to ensure that sustainability is an integral part of the design process. Issues such as energy conservation in lighting and power supply, re-use of ground water for the Tunnel Cooling Project and materials management are being integrated with the design.

Crime and Disorder

- 5.7 Consultation with the TfL Crime and Disorder Partnership Unit will inform the on-going detailed design.

TfL Group Issues

- 5.8 LU is working closely with other parts of the TfL Group, in particular TfL Major Projects, TfL Surface Transport and London Rail, to ensure that the scheme is integrated with other TfL schemes and where appropriate, the necessary protections or arrangements are put in place. This includes ensuring that the VSU proposals are integrated with the LU Public Private Partnership (PPP) line upgrades and also complement the emerging Victoria Transport Interchange scheme.

- 5.9 The VSU proposal contributes positively to the following TfL Strategic Priorities:
- Improve safety and security;
 - Reduce crowding and congestion;
 - Promote sustainable development;
 - Promote equality and inclusion;
 - Expand network capacity.

6.0 PUBLIC CONSULTATION

- 6.1 Wide consultation has been undertaken for the Scheme. LU has approximately 1,200 registered stakeholders within its database relevant to the VSU project. Letters have periodically been sent to stakeholders to keep them informed of Scheme progress and public consultation events.
- 6.2 A public exhibition was held during May 2007. Visitors were encouraged to comment on the current proposals by completing a leaflet available at the exhibition. A second public exhibition is planned for July 2007.
- 6.3 Two "Meet the Manager" events have been held in the last twelve months. These are aimed at LU customers using the station, which have informed them of progress of Scheme development as well as the current asbestos removal works within the Underground station.
- 6.4 There have been three press releases for the project; two announcing the Scheme and its progress and the 3rd being the commencement of the asbestos removal works.
- 6.5 LU has held meetings with and given presentations to many groups representing residents, businesses and other organisations. Significant support for the Scheme has so far been received.
- 6.6 Stakeholder engagement is continuing to ensure that parties affected by VSU are fully consulted, and where possible, agreements are in place prior to the TWAO public inquiry. Key parties include Network Rail, the Victoria Palace Theatre, Land Securities and the owners of the Abford House site (Abford House itself having recently been demolished) adjacent to the proposed VSU works in Wilton Road. A legal agreement has recently been signed with the owners of Abford House which secures a no-objection to VSU. Similarly, Heads of Terms have recently been signed between Land Securities and TfL to establish common agreement between the organisations. LU are also negotiating an agreement with the Victoria Palace Theatre prior to the TWAO Public Inquiry in order that their concerns are minimised or removed so far as practicable and appropriate.
- 6.7 A statement of consultation will be prepared and made available as part of the TWAO application.
- 6.8 In pursuing the VSU scheme LU is conscious of the need to strike a balance between the rights of the individual and the interests of the public. In the light of the significant benefits arising from the implementation of the Scheme, LU is of the view that it would be appropriate to apply for a TWAO that includes compulsory purchase powers. It does not regard such a

TWAO as constituting any unlawful interference with individual property rights and compensation will be paid under the statutory code to all landowners from whom land or rights in land is taken. LU is of the view that in all cases the acquisition of property rights by these means would be proportionate and justified.

7.0 ECONOMIC EVALUATION

7.1 LU has undertaken a full cost-benefit analysis of the Scheme using TfL's Business Case Development Manual. The Scheme has a BCR of 2.6:1, reflecting the major benefits that are derived from the upgraded station. The high benefits are a combination of:

- the reduction in congestion identified, using dynamic pedestrian modelling, to compare movements through the station under a 'do minimum' scenario against the upgrade scheme;
- provision of improved access, including step-free access between the street and the platforms and in assessing the on-street pedestrian travel time savings with the introduction of the proposed Bressenden Place ticket hall.

7.2 The appraisal includes full project implementation costs, with a conservative optimism bias of 66% as well as staff, operational, maintenance and mid-life renewal costs over the 60 year appraisal period.

7.3 The appraisal relates to an earlier version of the scheme design. Further work on a quantified appraisal has been progressing to assess the effects of a number of design improvements recently made to the Scheme. As these changes are expected to be beneficial over the previous design, it is expected that the benefit-to-cost ratio will be maintained or bettered under a revised appraisal. This revised appraisal will support the TWAO application.

8.0 COST, PROCUREMENT AND FUNDING

8.1 The VSU project outturn cost is currently forecast at £638m, which includes risk, contingency and inflation allowances totalling £268m. Provision within the Investment Programme (2005-2010) totals £112m, the bulk of the remaining expenditure being in the years after 2010. Spend to date (to June 2007) is £14m.

8.2 An earlier cost estimate of £509M, as declared in the TfL Investment Programme, relates to estimates that assumed an inflation rate of 2.5%. Indications are that forecast inflation will be much greater and therefore an average inflation rate of 7% has been assumed over the life of the project. Levels of inflation and construction price increases will be monitored as part of the risk management process. Where this is lower than currently provided, reductions in estimated final cost will be made accordingly.

8.3 Land acquisition for the scheme will cost £20M, relating to the purchase of surface and sub-surface rights for temporary and permanent acquisition of land for the Scheme, including land at 120-124 Victoria St. and 3-11

Bressenden Place which is required to construct the new Bressenden Place ticket hall and entrances. This land is currently owned by Land Securities and the Victoria Palace Theatre. The land will be compulsorily purchased using the powers obtained under the TWAO. However, negotiations are continuing in parallel with the owners in order to purchase the land by private treaty in advance of a TWAO being made.

- 8.4 LU has undertaken all procurement for the project in accordance with relevant legislation and internal TfL procedures. Professional services for scheme design and planning have been competitively tendered. The implementation works will also be competitively tendered.
- 8.5 Submission of the TWAO application does not require a decision to have been made on the procurement method for the implementation works and LU is continuing to assess the optimum procurement approach.

9.0 RISKS

- 9.1 LU has so far undertaken five quantified risk analyses for the Scheme. Further analysis will continue throughout the life of the project. A significant risk allowance has been made in the cost estimate, reflecting the stage the project is at and the risks to which it is exposed. There are risk management plans in place and risks will be mitigated to the extent practicable given the physical, schedule and financial constraints on the project.
- 9.2 The implementation of the Scheme is subject to obtaining the necessary TWA Order and associated consents. This involves an element of risk in terms of third party objections and the risks inherent in applying for consents to a local authority or to the Secretary of State. The management of these risks is integral to informing the on-going design development which seeks to mitigate as far as practicable third party concerns.
- 9.3 There are ongoing discussions with parties affected by the proposals, including Land Securities and the owners of the Victoria Palace Theatre. Land Securities own land required for VSU and, as mentioned earlier in this report, are pursuing the VTI development, for which a planning application is expected later this year. Heads of terms, although not contractually binding, have been settled with Land Securities. Amongst other things, they contain provisions to regulate the transfer of land for the purposes of the VSU project, with a view to obviating the need to use compulsory purchase powers. Work is also in progress with a view to ensuring that the VSU and VTI schemes are compatible, although VSU is not dependent upon VTI and the relevant assessments for the VSU will be conducted accordingly.
- 9.4 The discussions taking place with the owners of the Victoria Palace Theatre are with a view to reaching arrangements that provide for regulation of the VSU scheme such that its impacts upon the theatre and its use, particularly during the construction phase, are subject to appropriate controls.
- 9.5 Other steps being taken with a view to ensuring that the consents for VSU are efficiently obtained are seeking a planning permission for a building on the corner of Bressenden Place and Victoria Street (the so called "Corner

Site Development") before the TWAO application is made, if not before the TWAO inquiry starts and making arrangements with the utility companies involved to divert utilities in advance of the main VSU works.

- 9.6 LU has experience of the TWA process and has developed a fully populated project plan with all required activities, timescales and milestones identified. This plan will be use to manage and monitor the progress of the TWA application and decision making. A TWA working group has been established to ensure this programme has the correct level of resource, is monitored and any additional risks identified and where possible resolved.

10.0 PROGRAMME

- 10.1 The outline timetable for the project is summarised below.

Milestone	Date
TWAO application	Nov 07
TWAO Public Inquiry starts	Jun/Jul 08
Utility diversions start	Mid-2008
Secretary of State decision	Jul 09
Land acquired by LU	Oct 09
Main works construction start	Oct 09
Project completion	Oct 14

11.0 RECOMMENDATIONS

- 11.1 The TfL Board is requested to:

- (a) **note** the content of this paper;
- (b) **approve** the submission by LU of an application for a Transport & Works Act Order in respect of the proposed upgrade of Victoria station, subject to:
 - (i) the Managing Director London Underground agreeing the details of the final scheme; and
 - (ii) the consent of the Mayor,
 and
- (c) **approve** the delegation of authority to the Managing Director London Underground to:
 - (i) agree the final terms of the application for an Order under the Transport & Works Act for the Scheme; and
 - (ii) do all such further things as may be required in order to submit the application and achieve an order under the Transport and Works Act and any related planning direction (including, without limitation, entering into agreements with objectors and acquiring third party land or interests in land).

Attachments

Figure 1 Existing Victoria Underground Station

Figure 2 Proposed Victoria Station Upgrade

Existing Victoria Underground Station

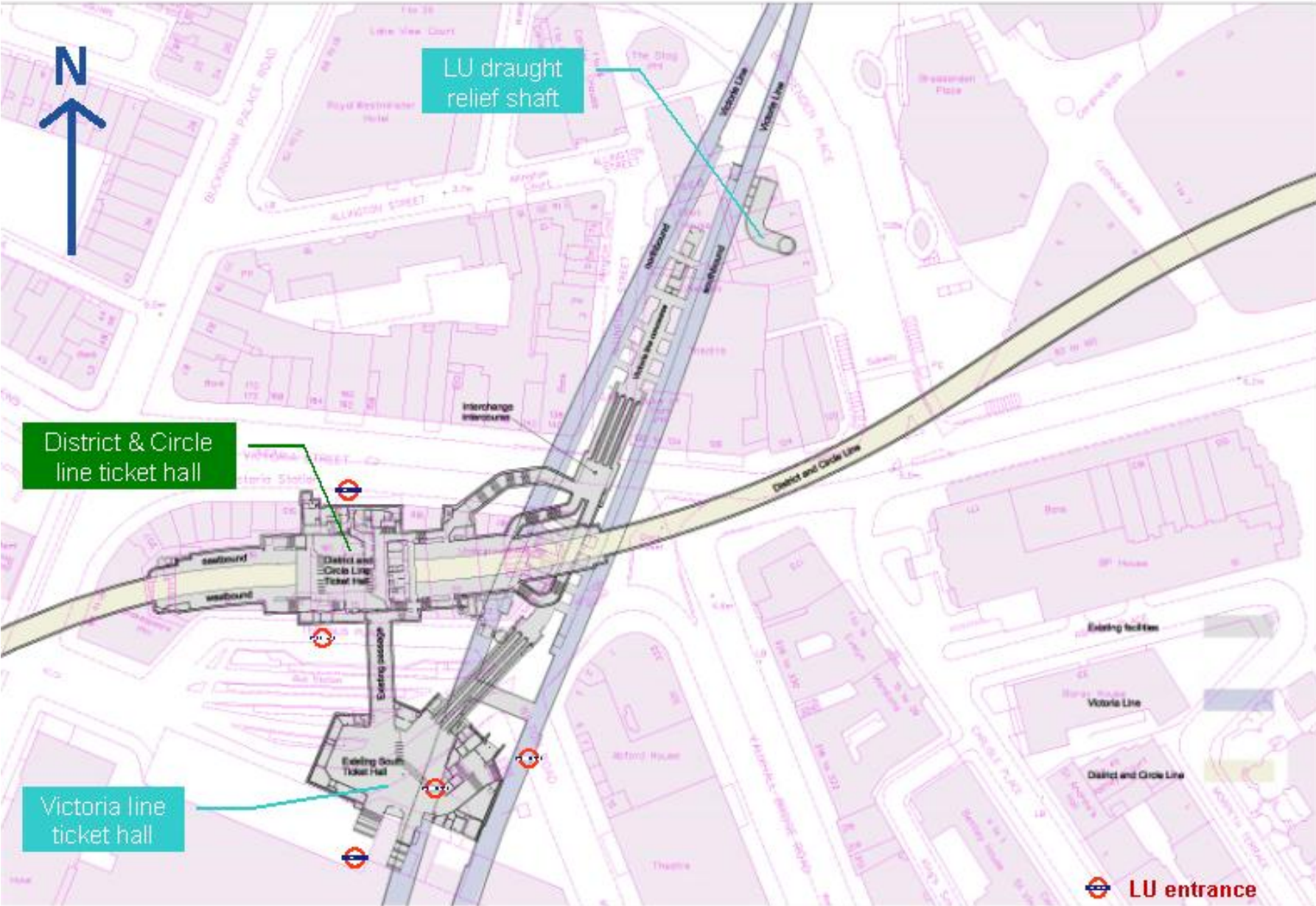

Figure &

Proposed Victoria Station Upgrade

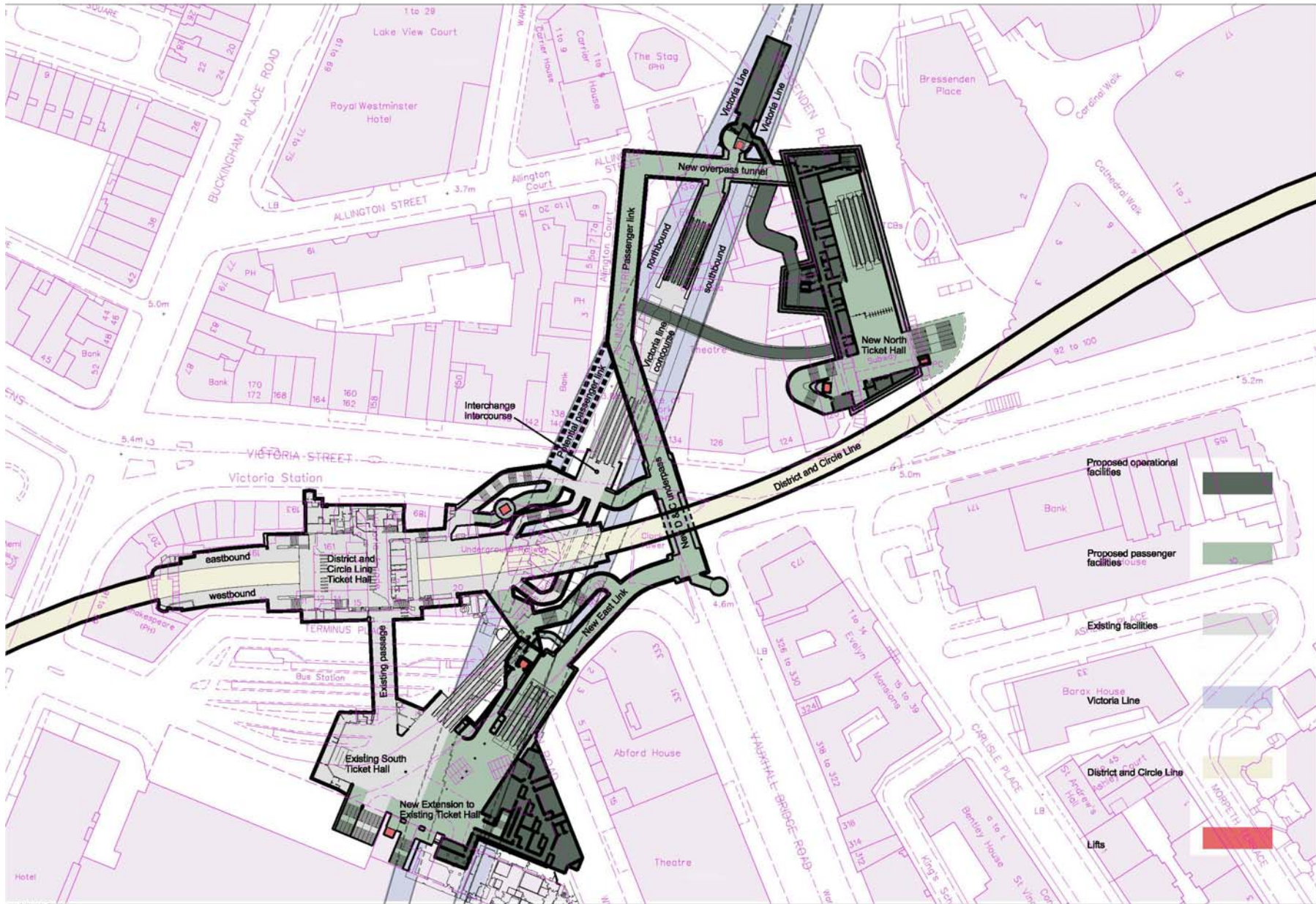

Figure 2



Victoria Station Upgrade

Tim O'Toole



Existing Victoria station

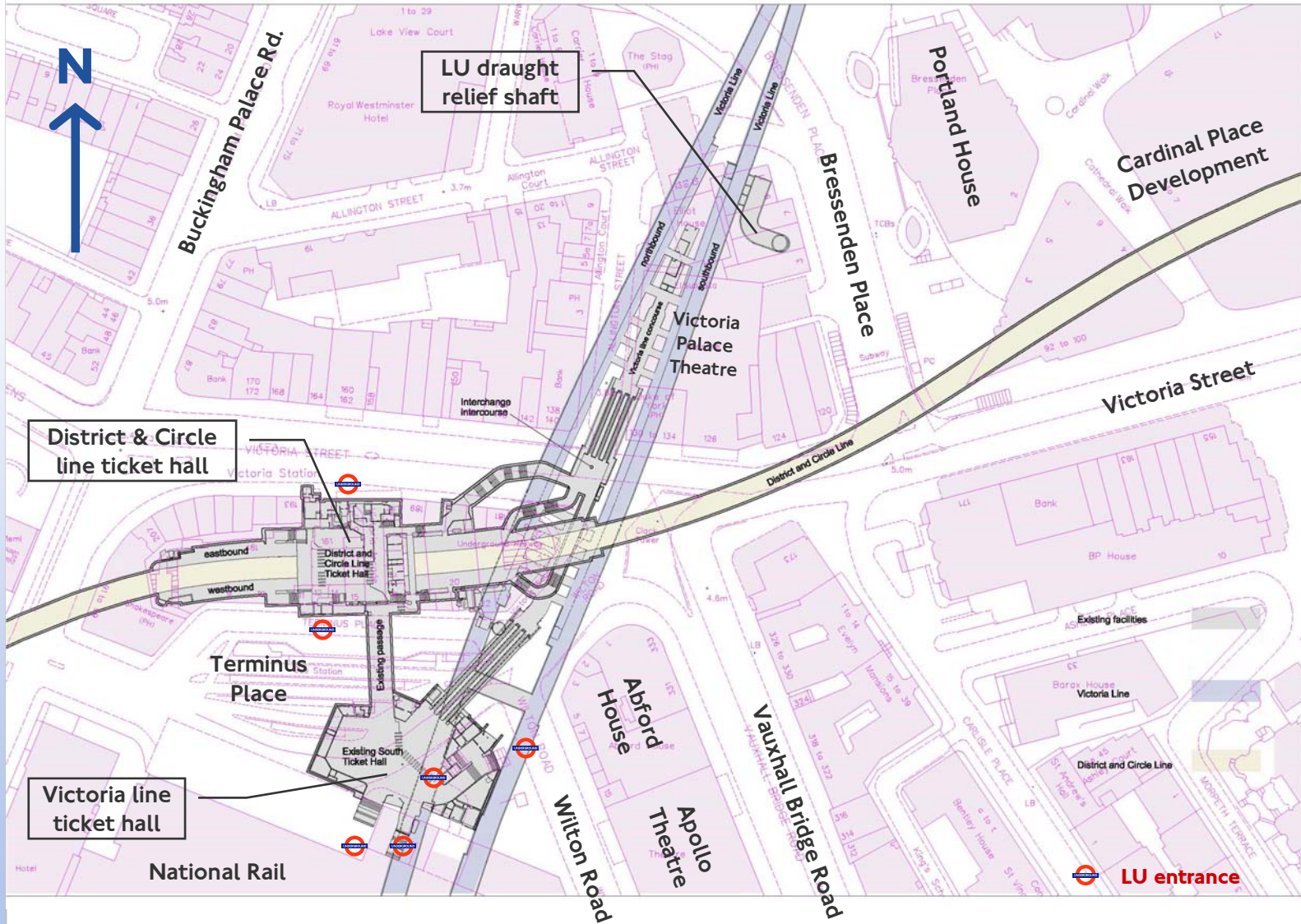



Proposed Victoria Station Upgrade

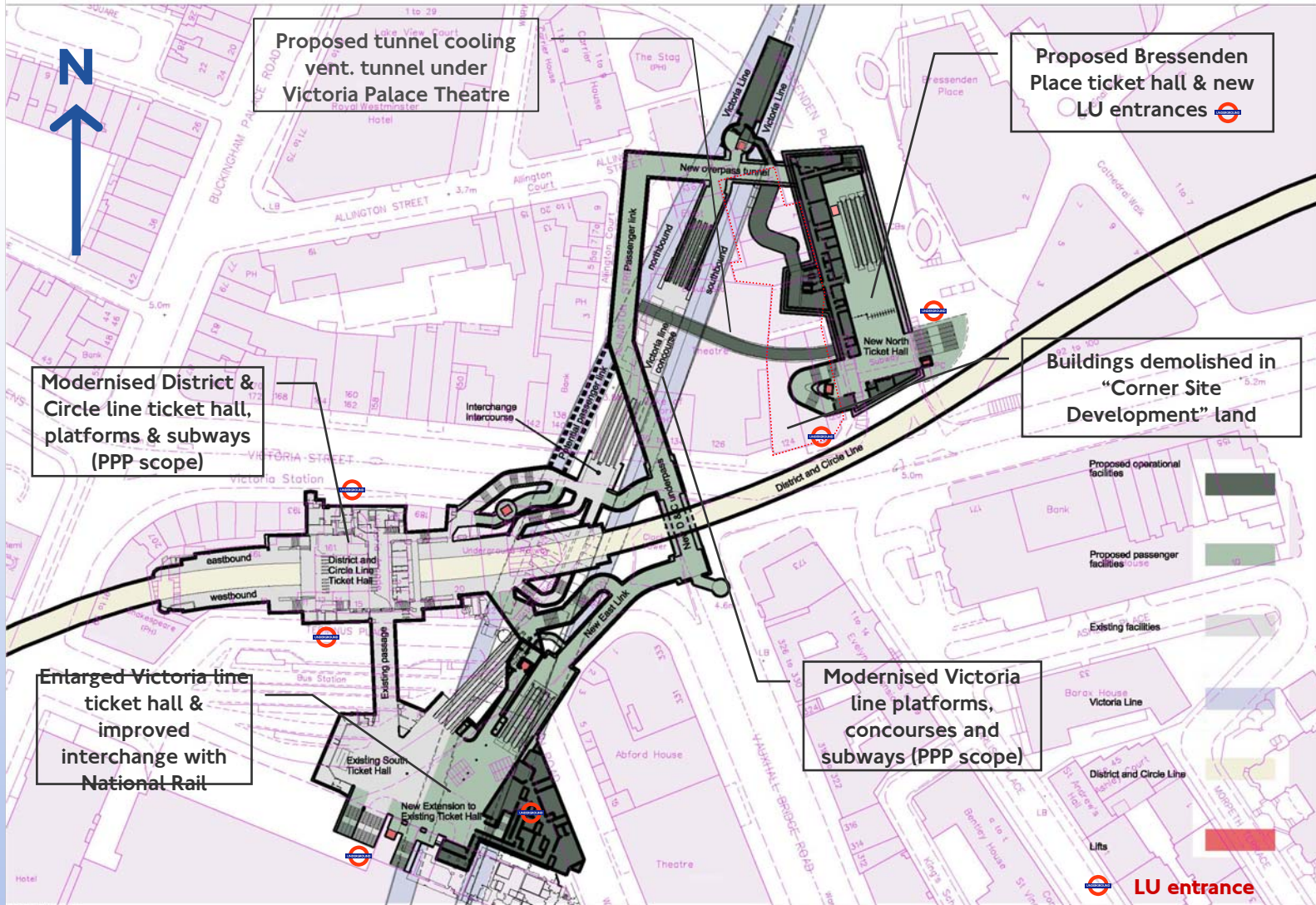

TRANSPORT FOR LONDON

BOARD

**SUBJECT: ARCHWAY STATION :
TRANSPORT & WORKS ACT CONSENT TO PROCEED**

MEETING DATE: 27 JUNE 2007

1. PURPOSE

- 1.1 To secure Board approval for London Underground Ltd to submit an application for an Order under the Transport & Works Act (TWA) in respect of the proposed step-free access upgrade project at Archway station. The project is budgeted within the TfL Investment Programme (code LU-PJ08).

2. BACKGROUND

- 2.1 London Underground Ltd (LUL) is developing a Foundation Network of step-free access (SFA) schemes, consistent with the Mayor's Transport Strategy and aimed at meeting the Mayor's target of one-third of Underground stations being accessible to mobility-impaired customers by 2013. This Foundation Network includes Archway station because of its town centre location and its function as an important bus/Underground interchange.
- 2.2 A TWA Order is required to implement the scheme, on the advice of LUL's legal advisers, because of the property rights needed over third party land to construct permanent facilities, provide working sites, and divert utilities' services. While it is hoped that the land and new rights required will be acquired by agreement, there is no guarantee that negotiations will be successful or that they will be concluded in a timely manner. The TWA Order, if made, would authorise the compulsory acquisition of the land and new rights required.

3. DESCRIPTION OF THE SCHEME

- 3.1 Archway station is in the London Borough of Islington (LBI), on the Northern line (High Barnet branch). It has a street-level ticket hall adjacent to the major road intersection, and platforms at deep level reached by escalators and stairs. Around 22,000 passengers daily start or finish their Underground journeys at Archway (equivalent to 7m p.a.), of which 20% interchange to or from bus services.
- 3.2 LUL's objective for the Archway scheme is to provide SFA in accordance with the Foundation Network policy. There are no proposals for congestion relief, as the existing station capacity is adequate for present and forecast future demand.
- 3.3 The SFA scheme, illustrated in Appendix A, comprises a lift from ticket hall to a new subway at intermediate level, from which the platforms (underneath Junction Road) are accessed by a further lift. This route-way mainly extends beneath the public highway and public realm rather than buildings, but is in various freehold and leasehold interests.
- 3.4 LUL plans to integrate the SFA installation at Archway with the PPP station modernisation works, as there is considerable overlap between the physical works required for the two projects in the ticket hall and platform areas.

- 3.5 Submission of the TWA Order for the SFA scheme (the station modernisation works do not require third party property rights) is planned for November 2007. Assuming consent is granted by Summer 2009, implementation on site is projected to commence late in 2009, with completion in 2012.
- 3.6 Archway station abuts the Archway Mall area, for which LBI are preparing a planning framework. The LU SFA scheme will be compatible with these proposals. The Archway Mall is also the location of a weekend street market, which will require at least partial re-location for the duration of the works, as the site will be required for access, plant working, and materials storage.

4. CURRENT STATUS

- 4.1 The Archway SFA project has completed outline scheme design (RIBA Stage D) and is currently awaiting the design milestone of Approval-in-Principle. Funding for detailed design (RIBA Stages E-G) and the TWA Order application will be sought from the MD Finance following PRG review in June/July 2007.
- 4.2 The project has reviewed numerous scheme configuration options during the feasibility and early design stages, with the objective of identifying an optimal operational arrangement, allied to consideration of minimising land take, operational and construction disruption, and adverse environmental impact. The scheme now being promoted has been discussed with LBI as the local planning authority, and has secured in-principle support.
- 4.3 Berwin Leighton Paisner LLP were appointed as legal advisers in December 2006 to advise on the town planning and consents issues affecting Archway (and also planned works at Highbury & Islington and Finsbury Park stations, also within Islington). Berwin's advice is that the TWA Order route is the most appropriate in order to achieve programme, for the reasons noted in 2.2 above.

5. KEY IMPACTS

- 5.1 The Archway project is aimed at improving accessibility consistent with the Mayor's Transport Strategy policy 4C.11. The proposals have a wider influence, and touch other strategies, as follows :-

Regeneration and Urban Realm Improvement

- 5.2 LBI is currently out to consultation on a Supplementary Planning document related to a Development Framework covering the station, the adjacent 1970s shopping mall and office complex and the nearby gyratory system. TfL is working closely with the local authority to ensure synergy between LUL's project and LBI's aspirations for the district.

Accessibility and Integration

- 5.3 The purpose of the project is to provide facilities to create a step-free route through the station from street to platform, thereby making them accessible to all potential users. This will be achieved by provision of two new lifts, linked by passageways. Step-free access between platform and train will be provided by using a form of platform hump, following the principle of systems currently under trial on the Waterloo & City line and at London Bridge. There are already good interchange facilities with bus services at Archway (all of which are accessible), and these will be retained under LU's proposals.

Equality and Inclusion

- 5.4 The scheme will benefit all those travelling to and from the areas around the stations, including residents, employed persons, and visitors, to have improved access to the

rest of London. Especially benefited will be those with significantly impaired mobility, people with health problems, and those burdened with heavy luggage or travelling with small children, who are unable to use the train services because of the current lack of step-free routes.

Environmental Considerations

- 5.5 The permanent works at Archway will be either below ground or incorporated within the existing station structure, so their long-term environmental impact will be minimal. Temporary works for shaft excavations will require extensive lorry movements and raise issues of noise, dust, and other construction-related impacts. Consultants have been appointed to undertake a full Environmental Impact Assessment of the scheme. Mitigation measures will be identified to avoid, reduce or remedy any negative environmental effects identified. There are currently no listed building, conservation area, special habitat or open space issues identified for the Archway scheme.

TfL Group Issues

- 5.6 LUL is working with TfL Surface to ensure that the necessary protections and arrangements are put in place in relation to street facilities and bus services. The Director of Strategy has been consulted in the preparation of this paper and confirms his support of the proposal. TfL London Rail are not impacted at Archway.

Human Rights

- 5.7 The Human Rights Act 1998 incorporated into domestic law the European Convention on Human Rights (“the Convention”). The Convention includes provisions in the form of articles, the aim of which is to protect the rights of the individual. In deciding to proceed with the application for the TWA Order LUL has duly considered the rights of property owners under the Convention, notably under the following Articles:

Article 1

This protects the right of everyone to the peaceful enjoyment of possessions. No one can be deprived of possessions except in the public interest and subject to the relevant national and international laws.

Article 8

This protects private and family life, home and correspondence. No public authority can interfere with these interests except if it is in accordance with the law and is necessary in the interest of national security, public safety or the economic well-being of the country.

Article 14

This protects the right to enjoy rights and freedoms in the Convention free from discrimination on any ground such as sex, race, colour, language, religion, political or other opinion, or national or social origin.

- 5.8 In the case of each of these Articles (and indeed other provisions in the Convention) LUL has been conscious of the need to strike a balance between the rights of the individual and the interests of the public. In the light of the significant public benefit which would arise from the implementation of the Archway project, LUL has concluded that it would be appropriate to submit an applications for the TWA Order. It does not regard the TWA Order (if made) as constituting any unlawful interference with individual property rights.
- 5.9 The opportunity will be given to landowners to make representations in the context of any public inquiry which the Secretary of State decides to hold in connection with the Order, and those directly affected by the Order will be entitled to compensation

proportionate to the loss which they incur as a result of the acquisition pursuant to the Compensation Code.

Sustainability

- 5.10 In the continuing project design LUL will seek to comply with all relevant policies, industry standards and good practice and to ensure that sustainability is an integral part of the design process. Issues such as energy conservation in lighting and power supply and materials management are being integrated with the design.

Crime and Disorder

- 5.11 The scheme project team will seek advice from the TfL Crime and Disorder Partnership Unit and incorporate it within the next stage of detailed design. No specific security or public order-related issues have been identified for Archway.

6. PUBLIC CONSULTATION

- 6.1 Public consultation is scheduled to take place throughout summer/autumn 2007 in advance of the TWA Order being submitted. This will take the form of leaflets for residents, businesses and station users, public exhibitions and presentations to particular interest groups such as amenity associations and local politicians.
- 6.2 LUL has been in regular dialogue with LBI Officers regarding the proposed schemes. Presentations to key councillors, Members of Parliament and London Assembly Members are planned to take place during June 2007.
- 6.3 A statement of consultation will be prepared and made available as part of the TWA Order submissions.

7. BUSINESS CASE EVALUATION

- 7.1 The Archway scheme forms part of LUL's strategy to make one third of all stations step-free by 2013. The benefits of step-free access are realised through the variety of journey opportunities opened up by this wider step free network, rather than on an individual station by station basis. The SFA Foundation Network, which includes Archway, has a business case benefit : cost ratio (based on current scheme costings) of 1.7 : 1.

8. COST, PROCUREMENT AND FUNDING

- 8.1 LUL's investment plans have budget for the Archway project of £45m (£25m in the current Investment Programme to March 2010). This figure is consistent with cost forecasts developed at the current stage of design. Independent consultants are being commissioned to undertake a thorough review of the costs provided by Tube Lines for the main construction works and those identified by LUL for other elements.
- 8.2 The preferred procurement route for the detailed design phase of the Archway project (including integration of the PPP station modernisation design) is to single source from Tube Lines Limited via the PPP-defined Major Enhancement Agreement (MEA) process. The procurement route for the implementation phases, following Secretary of State approval of the TWA Order, will be reviewed in the light of circumstances pertaining at that time.¹

9. RISKS

- 9.1. Implementation of the Archway scheme is subject to obtaining the third party land, and new property rights over third party land, needed to construct permanent

¹ In the event that TWA Orders are not confirmed, the PPP works will be resumed on a stand-alone basis.

facilities, provide working sites, and divert utilities' services. While it is hoped that the land and new rights required will be acquired by agreement, there is no guarantee that negotiations will be successful or that they will be concluded in a timely manner. The TWA Orders if made would authorise the compulsory acquisition of the land and new right required. The application for the TWA Order could involve third party objections, and the objections will need to be met in evidence at a public inquiry. In order to reduce the amount of opposition there will be a process of public consultation and negotiation with individual objectors and property interests. In deciding whether or not to make the TWA Order, the Secretary of State will need to be satisfied that the provisions in the Order are appropriate and justified.

9.2 Other key risks in relation to Archway include:

- Reaching agreement with property holders regarding access for surveys and protective works; termination of LU tenancies; sub-soil rights required for tunnelling; temporary dislocation to the weekend market and other users of the Archway Mall caused by its partial use as a working site. There may be some temporary restrictions on road traffic using Junction Road, but these cannot be clarified until detailed design is undertaken. It is envisaged that all of these can be mitigated by negotiation and, if appropriate, facilitation of an alternative trading location for the weekend market.
- The detailed design for the tunnelling work may identify engineering issues which could impact the scheme layout. This is most likely in the area where the lower lift is brought down to platform level, where there are limited clearances. This will be mitigated by focussing specifically on the known risk areas at an early stage in the design process, so that any necessary design modifications to achieve the scheme objectives are understood and evaluated without delaying the scheme programme.
- Stakeholders promoting or objecting to plans for the upgrading/regeneration of the Archway Tower and Mall area may seek to influence the LUL SFA project to secure their wider objective, with risk to the project of additional objections to the TWA Order. This will be mitigated by working with LBI officers and members, the local MPs and Assembly Members to keep the two programmes distinct but complementary. LU has already initiated minor scheme design changes to facilitate this separation and reduce the risk of objections.

10. OVERALL PROGRAMME

10.1 The key milestones for the Archway projects are as follows :-

Detailed design commenced	July 2007
Submission of TWA Order	November 2007
Detailed design completed	December 2008
Public Inquiry held	Spring/summer 2008
TWA Powers granted (assumed)	Summer 2009
Site works commenced	Late 2009
Site works completed	Mid-2012

11. RECOMMENDATIONS

11.1 The TfL Board is requested to :-

- a) note the content of this paper;

- b) approve the submission by LUL of an application under the Transport & Works Act for powers, including compulsory acquisition of land and other property rights, to undertake a scheme for provision of step-free access at Archway station, subject to consent of the Mayor;
- c) to delegate authority to the Managing Director LUL to :
 - i) agree the final terms of the application (including the land and interests to be subject to compulsory purchase) for the Order under the Transport & Works Act for the scheme;
 - ii) do all such further things and sign and/or seal such further documents, agreements or notices as are required in connection with the submission of the application for an Order under the Transport & Works Act for the scheme;
 - iii) do all such further things and take all relevant action thereon to promote the making of the Order for the scheme, including responding to any objections to the scheme or in connection with responding to any public inquiry that may be held in relation to the scheme;
 - iv) in the event that the Order is made, to do all such further things necessary to implement the powers and to undertake the step-free access scheme at Archway station.

PLAN OF PROPOSED ARCHWAY SCHEME (new works shown shaded)

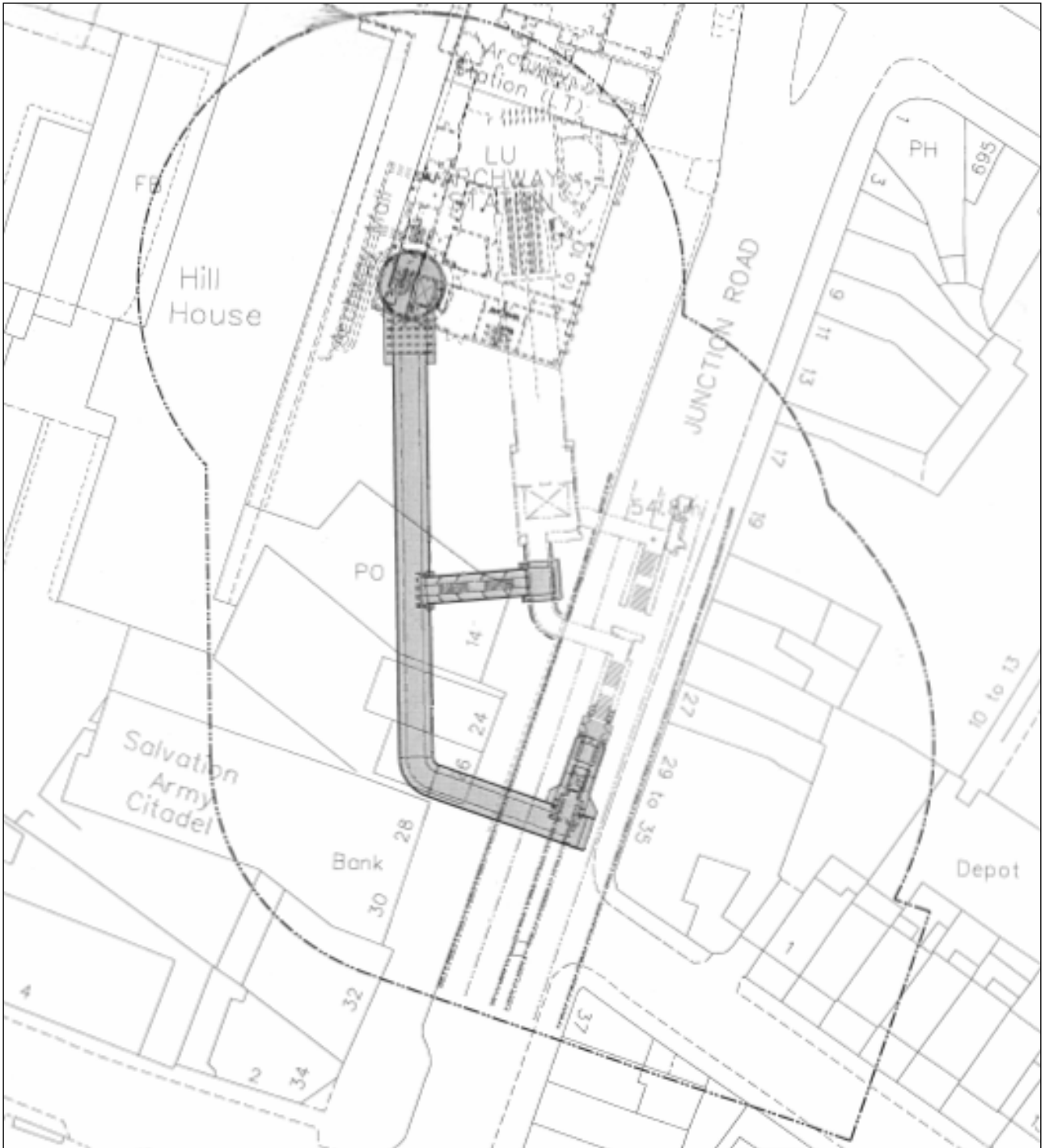



Archway Station Step-Free Access

Tim O'Toole



Current Station Layout

- Street level ticket hall leading via two escalators to lower concourse level
- Two corridors/staircases to platform level
- Spiral staircase and associated corridor/staircase provided limited capacity and secondary means of access
- Two deep tube platforms

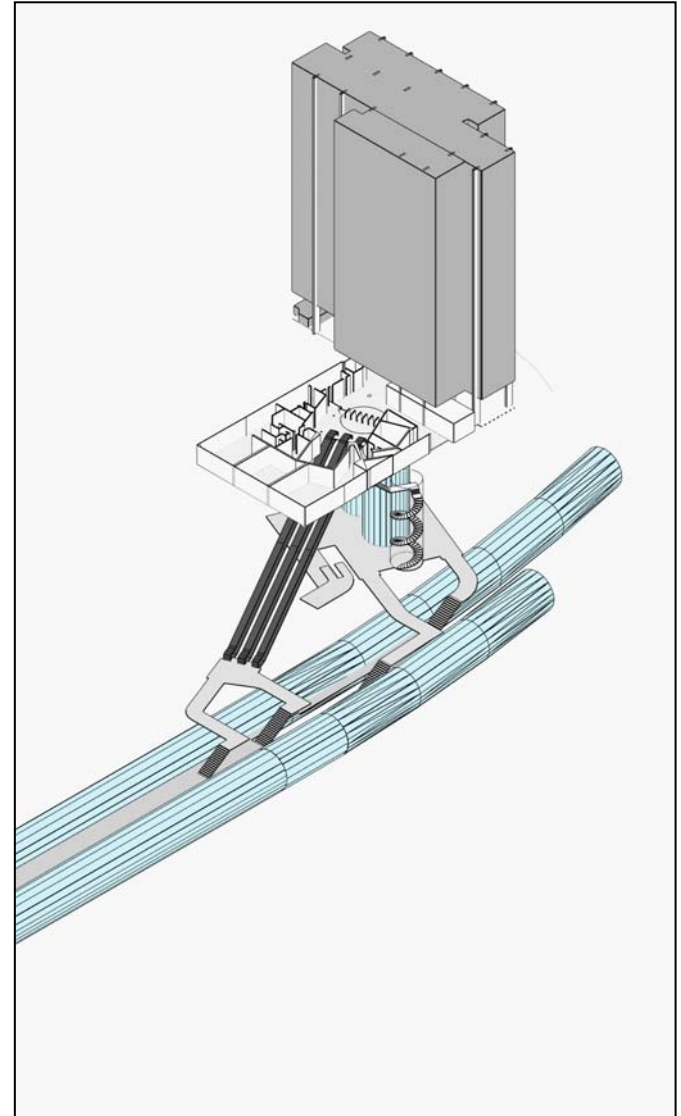



Proposed Station Layout

- New lift and staircase shaft within LU building, linked to ticket hall
- Resited, enlarged station supervisor's office
- New, low level passageway leading to second lift which gives access to platform level
- Link staircase provided for staff and emergency means of escape

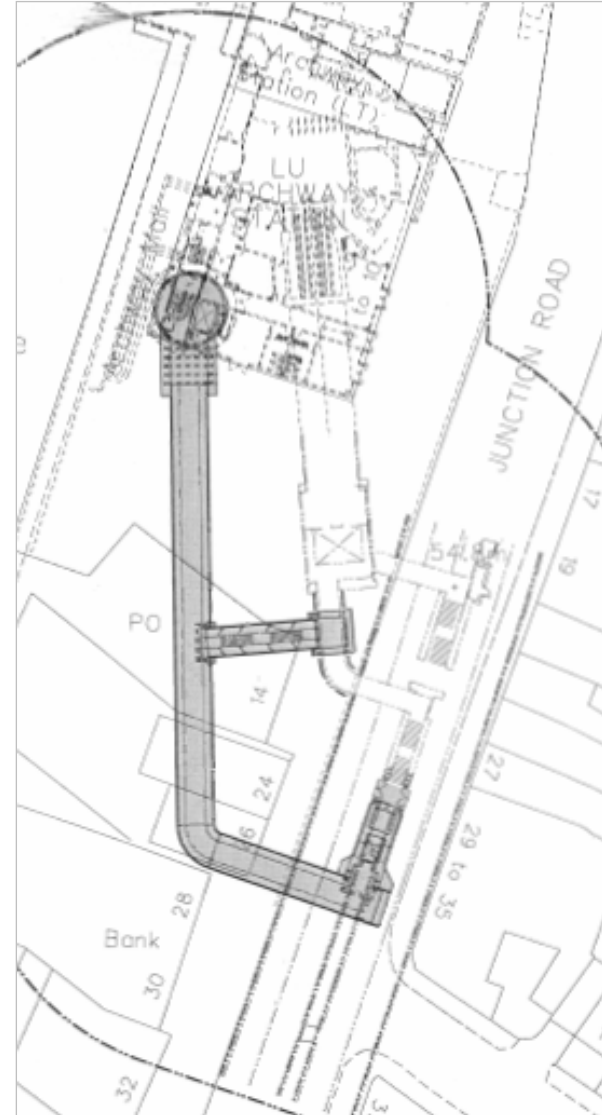

TRANSPORT FOR LONDON

BOARD

**SUBJECT: TAXI AND PRIVATE HIRE VEHICLES:
SCHEDULED AND AD HOC INSPECTIONS**

MEETING DATE: 27 JUNE 2007

1. PURPOSE

1.1 The purpose of this paper is to report to the Board on ad hoc and scheduled inspections of taxis and private hire vehicles (PHVs) licensed by TfL's Public Carriage Office (PCO). This follows a discussion at the February 2007 Board (ref. 07/02/07).

2. DECISION REQUIRED

2.1 The board is requested to note the strategic approach that the PCO is taking in respect taxi and private hire compliance and note the contribution this will have towards maintaining safe taxi and private hire services for the travelling public in line with legal requirements.

3. BACKGROUND

3.1 TfL is one of the world's largest licensing authorities, with some 130,000 licensees who provide London's taxi and private hire services. Of these, some 60,000 are vehicle licensees (split approximately 20:40 between taxi:PHV), with vehicles licensed annually.

3.2 The overriding purpose of vehicle licensing (via scheduled inspections) and vehicle compliance (via ad hoc inspections) is to make London's taxis and private hire vehicles (PHVs) safe for the travelling public. Scheduled licensing work supplemented by continuous compliance activity by the PCO should provide reassurance to the public and encourage high standards of safety.

3.3 Scheduled inspections are characterised as follows:

- They are carried out at least annually, by appointment with the vehicle owner (or licensee) who may also be a licensed driver, or taxi garage, or leasing company.
- All annual inspections are carried out on behalf of the PCO by SGS (United Kingdom) Ltd at their premises by their staff.
- Taxi inspection centres are at Tottenham, Hanworth and Deptford and owners have a choice of location.
- Annual taxi inspections are thorough, include a smoke test, and exceed the standard MoT test for cars.
- Mid-year inspections for taxis are planned to start at SGS centres in October 2007: these will incorporate essential safety checks including a smoke test and will be similar to an MoT test for cars.

- The annual cost of taxi inspections (both annual and mid-year) is proposed to be £178.
- Private hire inspections are undertaken at Hanworth, Enfield, Croydon and Woolwich, and again owners have a choice of location.
- Annual private hire inspections currently do not include the MoT-type safety checks, but PHVs will not pass their licensing inspection unless they present an MoT certificate, from a VOSA appointed MoT station, dated not more than 14 days before the licensing inspection.
- Licensed PHVs are required to have a mid-year MoT test, at a VOSA appointed MoT station, roughly six months after their annual licensing inspection.

Standards for tests carried out by SGS are set and monitored by the PCO. Vehicle data records are held by both SGS and the PCO.

3.4 Ad hoc inspections are characterised as follows:

- Inspections of either taxis and PHVs outside of the scheduled inspection regime.
- They are carried out by technically qualified PCO staff.
- No advance notice need be given to owners, and whoever is in control of the vehicle must comply with a reasonable request to inspect by a Public Carriage Examiner and/or authorised officer.
- They can be carried out on or off highway as long as they can be undertaken safely for all parties including other road users, and the vehicle is legally parked.
- Taxis, traditionally, have been subject to ad hoc inspections by the same PCO staff who carried out annual inspections. They would visit taxi ranks, for example, Heathrow and major railway stations, ask to see the driver's 'badge and bill' and carry out a brief vehicle inspection.
- PHVs are still relatively new to this procedure but have been subject to ad hoc checks from 2006 onwards. As PHVs cannot 'rank up', and if they are in motion they are generally carrying passengers or on their way to pick up passengers, the best places to inspect them are generally close to private hire operators' offices while they wait to be allocated bookings.
- In the cases of both taxis and PHVs, ad hoc inspections should aim to minimise the inconvenience to licensees and their customers.

3.5 Two other modes of operation are:

- **Planned fleet visits** are arranged with taxi proprietors at their premises, with the aim of checking and advising on maintenance methods in preparation for taxi inspections.
- **Special operations** are usually conducted with the Metropolitan Police and other agencies, including the PCO, near busy nightspots. The police are able to stop moving vehicles for mechanical inspection – taxi, PHV and suspected touts. If a vehicle is determined to be unsafe, this would normally result in the issue of a PG9 to prevent it from being used until the defects have been rectified.

3.6 Appendix 1 discusses the results of both scheduled and ad hoc inspections in recent years.

4. INFORMATION

4.1 Future Strategy For Maintaining Vehicle Standards

4.1.1 Strategy Refresh

The placing of scheduled inspections for taxis and PHVs with SGS plus the MoT testing of PHVs to VOSA qualified testers has offered the opportunity to improve the way that vehicle standards will be maintained in future. The PCO still sets the standards but the scheduled testing is carried out by SGS.

The PCO will ensure that SGS deliver the service as specified in the contract, through close contract management by PCO staff. Compliance of licensed vehicles is implemented directly by PCO staff and will focus on the following:

- The PCO will educate and support the licensed taxi and private hire services and aim to maintain positive relations with licensees. It is in all parties' interests to raise standards and reduce failures arising from inspections.
- To deliver safe taxi and private hire services for the travelling public in line with legal requirements.
- To conduct fair, proportionate, transparent and focussed ad hoc inspections which provide assurance that vehicles and any relevant documents are fully compliant with legislation.
- Compliance inspection work will be planned and often intelligence-led and documented, to ensure maximum impact over time.
- To ensure that illegal vehicles (and drivers) are identified and pursued, which in turn will improve the safety of the travelling public and provide a demonstrable deterrent to illegal drivers.
- Develop IM systems to support the above.

4.2 Partnership Working

The PCO will seek to fulfil its Compliance Objectives in partnership with various internal and external agencies and partners such as:-

- Owners and drivers of taxis and PHVs
- Transport Operational Command Unit (TOCU)
- Vehicle and Operator Services Agency (VOSA)
- City of London Police
- Congestion Charging Unit (CCU)
- Greater London Authority (GLA)

4.3 PCO Compliance Team

- Before April 2007, the PCO relied on having enough officers to carry out on-street compliance once scheduled inspections were covered. Due to seasonal variations in scheduled work, holidays and sickness on-street compliance was inconsistently applied.
- Since April 2007 the PCO has set up a dedicated 'on-street' compliance team consisting of highly qualified motor vehicle engineers with licensing experience of the taxi and private hire industries.

- The team consist of a Senior Vehicle Compliance Manager, 2 Compliance Managers and 8 Compliance Officers, all previously part of the PCO's technical licensing team.
- Licensing Officers will also work closely with the Compliance team on various compliance activities to bring about an integrated approach in relation to licensed operators, drivers and vehicles, for example, on street vehicle checks could result in cross-checks at operator's offices to ensure that driver's files and journey records are consistent.

4.4 PCO Compliance Vehicle

- Since February 2007 the PCO has commissioned a fully equipped compliance vehicle capable of carrying 8 people.
- The vehicle is fully TfL and PCO branded and is highly visible.
- The vehicle carries all the equipment required that enables the team to conduct comprehensive road side examination of taxi and private hire vehicles.
- The vehicle is fully Euro 4 emissions compliant and runs on LPG with petrol backup.
- The use of this highly visible compliance vehicle promotes the licensing authority and enables the PCO to maintain an ongoing presence at various locations throughout London.

5. CRIME AND DISORDER

TfL assesses its activities for the impact of Crime and Disorder under Section 17 of the Crime and Disorder Act 1998.

Inspections of taxis and private hire vehicles, whether scheduled or ad hoc, and other PCO compliance activities, improve the quality and legitimacy of London's licensed taxi and private services and help to reduce demand for illegal cabs (or touts).

6. RECOMMENDATIONS

6.1 It is recommended that the Board:

- a) Notes the strategic approach that the PCO is taking in respect taxi and private hire compliance; and
- b) Notes the contribution this will have towards maintaining safe taxi and private hire services for the travelling public in line with legal requirements.

APPENDIX 1A

RECENT COMPLIANCE ACTIVITIES

A1 Taxis

- There were 21,596 licensed taxis at the end of March 2007.
- The taxi licensee, the person to whom the licence has been issued, is required to ensure that the taxi remains fit for public use and conforms to the licensing authority (TfL) 'Conditions of Fitness'.
- Ongoing checks of this requirement are carried out by PCO Compliance Officers by way of ad-hoc 'on-street' inspections and some pre-planned fleet inspections.
- Licensees failing to comply may be reported to the Licensing Authority under the London Cab Order 1934.
- A summary of the last 3 years of taxi 'on-street' inspections conducted by Compliance Officers is as follows:-

Year	Number Examined	Number Unfit for Service	% Unfit
2006	2,348	154	7
2005	11,797	1197	10
2004	9,461	928	10

- The main reason for a vehicle to be declared "unfit" is mechanical condition.
- Other legal requirements such as insurance, road fund licence, taximeter and wheelchair equipment are also checked.
- The reason for the much lower amount of compliance work in 2006 was that in the final year of scheduled inspections at the PCO, there was less capacity for on-street work.

A2 Private Hire Vehicles (licensed in London from April 2004)

- There were 45,044 active licensed private hire vehicle licences in April 2007.
- The owner of a licensed private hire vehicle is required to ensure that it remains safe, comfortable and in a suitable mechanical condition for that use.
- Ongoing checks of this requirement are carried out by PCO Compliance Officers by way of ad-hoc 'on-street' inspections and joint initiatives.
- Owners failing to comply may be advised and/or reported to the Licensing Authority under the Private Hire Vehicles (London) Act 1998.
- A summary of the last year of private hire 'on-street' inspections conducted by Compliance Officers is as follows:-

Year	Number Examined	Number Unfit for Service	% Unfit
2006	821	134	16.3

- The main defects for which "unfits" were issued were:- tyres, insurance, radio equipment and accident damage. "Unfits" may contain more than one of these defect categories. In addition, checks are made on other legal requirements such as the correct display of licence discs.

Note: In order to create a stable licensing platform, encourage the trade to become licensed and allow for start up fleet re-generation to take place, full on-street inspections were not carried out until 2006. Private hire vehicle inspections have also been mainly carried out as part of formal joint initiatives with the Vehicle and Operator Services Agency (VOSA), TOCU and City of London Police.

APPENDIX 1B

RECENT SCHEDULED INSPECTION RESULTS

B1 Taxi Licensing Inspections

- A summary of the last 3 year's taxi licensing inspections annual first time pass rate is as follows;-

2006	48%
2005	42%
2004	44%

- Since April 2007, the taxi licensing inspection service has been conducted by TfL's service provider SGS UK Ltd using up to date electronic vehicle testing equipment. The use of this equipment provides greater consistency together with a greater transparency of the required standards.
- First time pass rates in the first 3 months of licensing taxis with SGS have been similar to those in the last year of inspections at the PCO, which was to be expected as the standards that had to be met were largely unchanged.
- The main reasons for failure were brakes, steering, lights and suspension.
- The introduction of mid-year inspections is expected to improve the first time pass rate.

B2 Private Hire Vehicle Inspections

- A summary of the last 2 years private hire vehicle licensing inspections annual first time pass rate is as follows;-

2006	75%
2005	76%

- It must be noted that private hire vehicle licensing does not include a full mechanical inspection of the vehicle as owners are required to have an MoT issued to the vehicle no more than 14 days prior to its annual licensing inspection.
- It would therefore be expected that the overall first time pass rate for private hire vehicles would be higher than those for taxis as the taxi test comprises a complete mechanical and legislative examination.
- The main reasons for failure were incomplete documentation, faults in the internal layout and damaged body work.

TRANSPORT FOR LONDON

BOARD

SUBJECT: TAXI AND PRIVATE HIRE LICENCE FEES

MEETING DATE: 27 JUNE 2007

1. PURPOSE

1.1 The purpose of this paper is to seek approval from the Board for changes in July 2007 to private hire licence fees.

2. DECISION REQUIRED

2.1 The Board is requested to:

- a. Note the intended changes to taxi and taxi driver licence fees with effect from Monday 2 July 2007.
- b. Approve the making of regulations to take effect from Monday 2 July 2007 that will implement new private hire operator fees and 5 year licence fees.

3. BACKGROUND

3.1 TfL is the licensing authority for taxi and private hire services in London.

3.2 Charges for taxi and taxi driver licences were subject to maximum prescribed limits until the Transport Act 1981 introduced changes that enabled the licensing authority to determine charges. Since then, licence fees have been reviewed every year and set to recover the full cost of the PCO taxi licensing functions.

3.3 Sections 6(5) and 8(8) of the Metropolitan Public Carriage Act 1869 (amended by the Greater London Authority Act 1999) enabled the licensing authority to charge for taxi driver and taxi applications and for licensing application tests and re-tests, as well a charging for driver and vehicle licences. Since then changes have been introduced to reflect the principle that licence holders and applicants alike should pay for the costs of the licensing resources they use.

3.4 Private hire operator licensing in London was introduced in January 2001, with private hire driver licensing introduced in April 2003, and private hire vehicle licensing introduced in April 2004. The level of charges for PHV related licence fees are set by regulations made by TfL.

3.5 Under paragraphs 4.2(k) and 19 of TfL Standing Order Number 2: Scheme of Delegation, the amendment of PHV regulations for the purpose of ensuring that licence fees cover the costs of licensing activities is a matter

delegated to the Commissioner. Whilst the making of these regulation amendments is not a matter reserved to the Board, the Commissioner has indicated that he would wish the Board to consider and approve the changes.

3.6 Regulations are required to make changes in respect of private hire operators only. No changes are proposed to private hire driver and vehicle fees on this occasion.

3.7 A change in taxi driver and taxi licensing fees does not require regulations. It is an administrative decision for the Chief Officer responsible for the PCO.

4. INFORMATION

4.1 PROPOSALS FOR JULY 2007

4.1.1 The following fees and charges are intended to take effect from Monday 2 July 2007.

Drivers

- (1) Taxi driver application fee increased from £25 to £50 (100%).
- (2) Taxi driver three-year licence fee reduced from £224 to £199 (11%).
- (3) Written Knowledge pre-appearance written test fee (All-London, Green-badge, applicants only) increased from £25 to £50 (100%).
- (4) One-off Knowledge 'appearance' fee for Suburban (Yellow badge) driver applicants increased from £100 to £150 (50%).
- (5) One-off Knowledge 'appearance' fee for All-London (Green badge) driver applicants increased from £150 to £200 (33%).

- (6) Private hire driver application fee remains at £105
- (7) Private hire driver three-year licence fee remains at £157.
- (8) **Total private hire driver fees remain at £262** (Items 6 and 7 combined).

Vehicles

- (9) Taxi licensing application and inspection fee remains at £107.
- (10) Taxi annual licence fee increased from £35 to £71 (103%).
- (11) **Total taxi fees increased from £142 to £178 (25%)** (Items 9 and 10 combined).

- (12) Private hire vehicle application and inspection fee remains at £82.
- (13) Private hire vehicle annual licence fee remains at £27.
- (14) **Total private hire vehicle fee remains at £109¹** (Items 12 and 13 combined).

Private Hire Operators

- (15) Private Hire operator licence application fee decreased from £703 to £450 (36%).
- (16) PH (small) operator five-year licence fee decreased from £550 to £450 (18%).
- (17) PH (standard) operator five-year licence fee increased from £1,707 to £2,680 (57%).
- (18) **Total PH operator fees (small) decreased from £1,253 to £900 (28%)** (Items 15 and 16 combined).
- (19) **Total PH operator fees (standard) increased from £2,410 to £3,130 (30%)** (Items 15 and 17 combined).

¹ In addition to the licence, vehicles more than 1 year old must have an MoT test twice a year. The current maximum MoT fee is £50.35.

(20) PH operator licence variation fee remains at £25.

4.1.2 Application fees and Knowledge fees have traditionally been set at low levels to ensure that the fees did not constitute barriers to entry. However, following consultation with the taxi trade, licence fees for drivers were restructured in April 2005 to redistribute small amounts of expenditure from licensed drivers to applicants as a modest step along the line of equitable charging arrangements. The PCO has seen significant increases over the past few years in the number of new taxi driver applicants, and are therefore confident that this has not been a detrimental step.

4.1.3 Consequently in order to continue to reflect actual costs there is the intention to further redistribute costs to applicants as set out in paragraph 4.1.1 above. The situation will continue to be closely monitored.

4.1.4 There have been no changes to taxi driver licence fees, including application and Knowledge fees, since April 2005.

4.1.5 There are no proposals to change private hire driver fees, which have remained unchanged since April 2004.

4.1.6 Taxi licensing fees are increasing overall by £36 to reflect the planned introduction, this coming October, of mid-year safety inspection as a condition of licensing noted by the Board at its meeting on 7 February 2007. At that time the Board was informed of the wide ranging measures that were being introduced to modernise and improve arrangements for the delivery of taxi licensing and inspections following the outcome of a best value review. The measures included the transfer of the inspection services to SGS. The transfer took effect as planned on Monday 2 April 2007.

4.1.7 The cost of the annual taxi licensing inspection remains unchanged.

4.1.8 There are no proposals to change private hire vehicle fees on this occasion.

4.1.9 The balance between the fees charged in respect of small private hire operators (one or two vehicles) and standard private hire operators (three or more vehicles) is being changed to reflect adjustments to the distribution of PCO staff resources allocated to operator licensing. The effect is to reduce the cost of the unified application fee for both small and standard operators, and increase the cost of the standard private hire operator five-year licence whilst making a modest reduction in the cost of the small operator five-year licence.

4.1.10 Personal visits by Licensing Officers drive much of the cost of operator licensing over the five-year term. The PCO is reviewing the need and format for such visits by PCO Licensing Officers to very small operators in order to reduce their costs.

4.1.11 The PCO is also reviewing the structure of operator licence fees, and will consider options and assess the impacts on licensees. The analysis and outcome will provide the basis for consultation.

4.2 IMPACT ON THE TRADES

4.2.1 Changes in taxi and taxi driver licence fees are included (as a very small element) in the cost-of-living index and are therefore recovered by the drivers through fares.

4.2.2 The proposed increase in respect of standard private hire operators is not considered to impose an unreasonable burden on the trade.

4.2.3 The fees for both taxi and private hire continue to compare favourably with fees charged by licensing authorities elsewhere, and this is especially so when London's office accommodation, staff and general business costs are taken into account.

4.2.4 A comparison with Birmingham City Council licence fees are as follows.

- Taxi driver licence fees are £172 per annum (£516 over three years) compared to TfL three-year licence fees of £249 (excluding Knowledge fees).
- Taxi licence fees are £200 per annum compared with TfL's intended fee of £178.
- Small PH Operator fees (up to five vehicles), over a five-year period, would be £3,430 compared with TfL's proposed fee of £900 for a five-year licence for small operators (one or two vehicles).
- Standard PH Operator fees would be £6,010 compared with TfL's proposed fee of £3,130 for standard operators (three vehicles or more).
- Private hire driver fees over three years would be £513 compared with £262 for TfL's three-year licence fee.
- Private hire vehicle annual licence fees are £172 compared with TfL's annual fee of £109.

4.3 ALTERNATIVES

4.3.1 Fund the full costs of licensing through TfL grant, or through a combination of grant and fees. There is no justification to use TfL's financial resources to subsidise taxi and private hire businesses, particularly when the costs in the former are recovered through fares and the prices in the latter trade are not regulated.

5. EQUALITIES

5.1 As noted in paragraph 4.1.2 of this paper, the introduction of application fees and other fees associated with the Knowledge of London for taxi driver applicants do not appear to have deterred applicants, as evidenced by significant increases in the level of applications received by the PCO over the past few years. It is, therefore, considered unlikely that taxi driver applicants will be deterred by the intention to increase these types of fee to more fully reflect the principle that licence holders and applicants alike should pay for the cost of the licensing resources.

6. CRIME AND DISORDER

6.1 TfL has agreed to assess its activities for the impact of crime and disorder under Section 17 of the Crime and Disorder Act 1998.

6.2 There are no implications for crime and disorder as a result of this paper to the Board.

7. RECOMMENDATIONS

The Board is asked to approve:

- (1) The intended changes to taxi and taxi driver licence fees with effect from Monday 2 July 2007.
- (2) The making of regulations to take effect from Monday 2 July 2007, that will implement new:
 - (i) Private hire operator application fees; and
 - (ii) Private hire operator five-year licence fees.

Routing Sheet

Meeting	Board
Date	June 2007
Name of paper	Best Value Performance Plan (BVPP)

Name	Signature	Date
Stephen Critchley Chief Finance Officer		
Steve Allen MD Finance		
Nigel Marson Interim MD Group Marketing & Communications		
Gareth John Director of Legal & Compliance		
Ellen Howard Director of Corporate Governance		

TRANSPORT FOR LONDON

BOARD

SUBJECT: BEST VALUE PERFORMANCE PLAN (BVPP)

MEETING DATE: 27 JUNE 2007

1. Introduction

1.1 Government introduced Best Value via the Local Government Act 1999 and TfL is specified as a 'Best Value' authority under that Act. As such, TfL has a duty to secure continuous improvement in the way that its functions are exercised having regard to economy, efficiency and effectiveness.

1.2 In practical terms, Best Value legislation requires TfL to:

- Carry out reviews of its services having regard to economy, efficiency and effectiveness. The previous requirement to review all of its services was relaxed in March 2002 and the number and scope of reviews are no longer prescribed.
- Monitor and compare performance across a range of statutory best value performance indicators (BVPI's) and report on such annually.
- Publish summary performance data by 31 March each year, although Best Value authorities have discretion as to the content and method of communication.
- Produce annually by 30 June each year a BVPP in accordance with the guidance published by Government. For Best Value authorities such as TfL who have achieved either a 'good' or 'excellent' rating from its Comprehensive Performance Assessment (CPA)¹ the detailed requirements have been relaxed.

1.3 TfL's compliance with Best Value legislation is subject to annual audit by external auditors, KPMG. The annual audit includes a review of the BVPP both for general compliance with legislation, and also specifically in relation to the content and accuracy of the performance indicators. The outcome is reported to TfL's Audit Committee by KPMG as part of the annual Data Quality Review.

2. Detailed requirements for the BVPP

2.1 TfL is required to publish a Best Value Performance Plan (BVPP) by 30 June each year. Detailed guidance for the requirements of the BVPP is contained within government circulars published by the Office of the Deputy Prime Minister

¹ TfL achieved an 'excellent' rating from its Initial Performance Assessment the Audit Commission equivalent of CPA as applied to Local Authorities

(ODPM)²; the current circular applicable is 05/2006 which sets out TfL's statutory obligations.

2.2 The required content of the BVPP is:

- A brief summary of TfL's strategic objectives and priorities for improvement,
- Arrangements for addressing TfL's improvement priorities,
- The out-turn Best Value Performance Indicators (BVPIs) for 2006/07 with associated commentary, and targets for the following year, and
- A brief statement on contracts. TfL is required to certify either that there were no contracts awarded during the year which involved a transfer of staff, or that those let, where applicable, complied with the Code of Practice on Workforce Matters in Local Authority Service Contracts.

3. 2007 BVPP

3.1 In common with previous years, and in accordance with best practice, TfL has integrated the production of the BVPP with its business and corporate planning process and resultant publications. Hence the abbreviated BVPP (see appendix 1) is published as an annex to the 2007/08 – 2009/10 business plan, published in November 2006.

3.2 The contents of this Annex are:

- The out-turn Best Value Performance Indicators (BVPIs) for 2006/07 with associated commentary and comparison,
- A statement on contracts, and
- A small amount of additional information relating to business improvement processes that is not contained in the main business plan text.

3.3 The Annex contains outturn performance information against the BVPIs. These are specific indicators prescribed by Government – TfL has no control over the areas to be measured or their methodology. As such, they are not representative of TfL's activities, but where appropriate are integrated into the wider performance monitoring and reporting framework. There are significant changes in some of the BVPI figures when comparing 2006/07 performance against target or prior year outturn and an explanation for such is given in the commentary for that indicator.

3.4 Final year outturn information has been provided for all of the prescribed performance indicators and has been signed-off by the responsible Director.

3.5 The BVPP will be audited by KPMG, TfL's appointed external auditors. As in previous years, the BVPP will be published on the TfL website by the end of June.

4. Future Developments

4.1 Government are currently working on the new national set of performance indicators, the result of which they expect to announce in Autumn 2007. The

² ODPM became the Department for Communities and Local Government in May 2006

proposal is to reduce the number of national indicators from the current level (600-1200) to a single set of around 200 which will be designed to measure national priority outcomes.

- 4.2 Under the Government's current plans, the new performance framework and single set of national set of performance indicators will be phased in from 1 April 2008 with full implementation from 2009/10. Therefore, 2007/08 will be the last year of Best Value Performance Indicators.

5. Impact on Crime and Disorder

- 5.1 There is no direct impact on crime and disorder arising from the contents of this paper. However, there is an indirect impact resulting from the monitoring of the average time taken to repair street lighting fault indicator contained within this paper.

6. Recommendation

The Board is asked to:

- APPROVE the contents of this Annex to the 2007/08 – 2009/10 business plan to form the overall 2006/07 BVPP
- DELEGATE authority to the Managing Director, Finance to make any changes prior to publication

Meeting: Board
Date: 27 June 2007
Title: BEST VALUE PERFORMANCE PLAN (BVPP)
Version: 1

Authors	Andy Lacey Group Improvement & Efficiency Manager	
	Gareth Powell Head of Group Performance	
Sponsor	Stephen Critchley Chief Finance Officer	
For queries please contact	Andy Lacey Group Improvement & Efficiency Manager	Telephone: 020 7126 3942 AndyLacey@TfL.gov.uk

Annex to the 2007/08 – 2009/10 Business Plan (Best Value Performance Plan)

Introduction

TfL is required, as part of the Local Government Act 1999 and supplemented by ODPM circular 05/2006 to publish a Best Value Performance Plan (BVPP). TfL, in line with good practice, integrates its improvement planning with its business plan process. The 2007 BVPP is integrated into its 2007/08 - 2009/10 business plan, which was published in November 2006. This Annex to that plan contains supplementary outturn performance information and other statements that TfL is required to publish.

Strategic objectives and priorities for improvement

TfL's strategic objectives and overall priorities for improvement are outlined in both the summary and main text of the business plan.

TfL and other functional bodies of the GLA group underwent an Initial Performance Assessment (IPA), carried out by the Audit Commission which concluded in November 2004. IPA is a version of Comprehensive Performance Assessment (CPA) which has been concluded for all top tier Local Authorities and district councils in England. The aim of the process was to assess the Authority's capability to deliver excellent outcomes for local people. TfL was awarded the top rating of '**Excellent**' - a copy of the Audit Commission inspection report can be found on their website at

<http://www.audit-commission.gov.uk>

Whilst TfL is rated as 'excellent' overall, there were a number of areas for improvement identified in the report, which TfL recognises. As an 'excellent' organisation, TfL was not required to develop a formal improvement plan but nevertheless, has developed a work programme which pulls together the various initiatives being undertaken to address these issues. The 'areas for improvement' are grouped around five broad themes:

- Partnership working and shared priorities, such as developing our relationship with stakeholders and having greater clarity in respect of the decision making process.
- Achieving the benefits of 'one TfL', for example implementing shared services for corporate activities and realising associated benefits.
- Service quality improvements, such as improving the capacity of transport systems and infrastructure.
- Challenge through scrutiny, transparency and learning, such as developing greater opportunities for shared learning across the GLA Group.
- Reducing travel demand and PPP issues, an example being that our plans give comparatively less weight to reducing the need to travel.

The Audit Commission have, through the Direction of Travel process, assessed TfL's progress against these areas for improvement and concluded that 'good progress has been made in completing the actions in the improvement plan. To date of the previously agreed 49 actions included in the original improvement plan 42 have been completed, the remaining 7 actions are ongoing, and in addition 4 new ones have been added to the plan.'¹

¹ Source: Audit Commission 2006 Annual Audit and Inspection Letter

Arrangement for addressing TfL's improvement priorities

TfL has a number of arrangements in place for addressing improvement priorities.

TfL's Business Planning Guidelines are distributed throughout the organisation in April each year. Each business unit is required to identify improvement opportunities and efficiencies not only for the coming year, but for the life of the Plan. This bottom up approach ensures that improvement planning is fully integrated into the overall business planning process. The business units are also required to review their programme of improvements and reviews, to ensure it is the most relevant and appropriate at that time. This approach allows flexibility to meet the business units' needs.

Internal Audit has an established programme of reviews which is agreed by the Audit Committee, but additional reviews can be added by the Director of Internal Audit if necessary.

TfL's future business improvement programme has been influenced by the:

- Outcomes of the IPA review in response to the 'areas for improvement',
- Need to support the business plan in relation to key decisions which need to be made in respect of existing arrangements for service delivery, and
- Ongoing identification and realisation of efficiency gains.

The anticipated outcomes of this process will be a scheme of improvements, the adoption of best practice throughout the business, and continued attention to maximise efficiencies at all levels.

Statement on contracts

TfL confirms that during 2006/07, three contracts were awarded which involved a staff transfer and certifies that it complied with the requirements in the Code of Practice on Workforce matters in Local Authority Service Contracts.

Best Value Performance Indicators

This section sets out the Best Value Performance Indicators (BVPIs) that have been prescribed by Department for Communities and Local Government (DCLG) for TfL in 2006/07. Also included are the performance out-turn figures for 2005/06 (where applicable), the target and outturn figures for 2006/07, and targets for 2007/08.

The comparisons against other authorities have been made against the most recent data available, which relates to 2005/06.

BV No.	Title	Page
Transport Best Value Performance Indicators		
BV 100	Temporary road closures	4
BV 102	Passenger journeys on buses	5
BV 165	The percentage of pedestrian crossings with facilities for disabled people, as a proportion of all crossings in the authority area	6
BV187	Percentage of the category 1, 1a and 2 footway network (on TLRN) where structural maintenance should be considered.	7
BV215a	The average number of days taken to repair a street lighting fault, which is under the control of the authority.	8
BV215b	The average number of days taken to repair a street lighting fault, where the response time is under the control of a DNO.	8
BV223	Percentage of the authority principal road network where structural maintenance should be considered.	9
BV99	Road Safety – number of road accident casualties	10-11
Corporate Health Best Value Performance Indicators		
BV 2a	Equality standard for local government	12
BV 2b	Duty to promote race equality	12
BV 8	Percentage of invoices paid on time	13
BV 11a	Top 5% of earners : women	13
BV 11b	Top 5% of earners : ethnic minorities	14
BV 11c	Top 5% of earners : with a disability	14
BV 12	Working days lost due to sickness absence	15
BV14	Percentage of early retirements	16
BV15	Percentage of ill-health retirements	16
BV16	Percentage of employees with a disability	17
BV17	Ethnic minority representation in the workforce	17
BV156	Buildings accessibility to people with a disability	18
Best Value User Satisfaction Surveys		
BV103	Satisfaction with public transport information	19
BV104	Satisfaction with local bus services	19

Transport Best Value Performance Indicators

BV100 Temporary road closures	2005/06 Actual	2006/07		2007/08 Target
		Target	Actual	
Number of days of temporary traffic controls or road closure on traffic sensitive roads caused by local authority road works per km of traffic sensitive roads	0.088	0.088 51 days	0.436 253 days	0.43 250 days
<p>Comment on performance</p> <p>This indicator is measured for traffic sensitive roads controlled by TfL. For TfL this is the Transport for London Road Network (TLRN), of which all 580 km are treated as traffic sensitive.</p> <p>TfL's policy is to programme works to avoid road closure on the TLRN during daytime hours. However, there is a balance to be struck between keeping the network open and the need to renew London's road network as part of the TfL Investment Programme, and there are occasions when a longer period of closure or traffic control (e.g. at weekends) is more effective than frequent short closures (e.g. overnight). Similarly, where diversions are available which will accommodate displaced traffic, it is often more desirable to effect closures and work for 24 hour periods (or extended shifts), where residents will not be inconvenienced or disturbed.</p> <p>The 2005/06 figure of 0.088 represented 51 days of traffic control, of which only 1 day was a full closure, but excluded the closure of Battersea Bridge for 118 days for structural repair after being hit by a barge.</p> <p>The 2006/07 capital maintenance programme identified major re-waterproofing works that were required on the A40 Marylebone Flyover, which was closed for 31 days as there was a reasonable diversion route. There was a further 63 days of closure at seven locations across the network where closure was the best option. Single Alternate Lane working (SALT) was maintained for 159 days on various schemes. The total of 253 days is equivalent to a BVPI value of 0.436.</p> <p>TfL's performance is better than the 2005/06 median performance for all authorities of 0.6.</p>				

BV 102 Passenger journeys on buses	2005/06 Actual	2006/07		2007/08 Target
		Target	Actual	
Number of local bus passenger journeys originating in the authority area undertaken each year (millions)	1,816	1,844	1,880	1,897
<p>Comment on performance</p> <p>The 2006/07 bus passenger journey figure shows a 3.5% growth compared to last year, and follows a period of significant growth of 40% between 1999/2000 and 2004/05. Growth is expected to continue, but at a somewhat reduced rate.</p> <p>Patronage was above target for 2006/07 despite lower than expected growth in the previous year. The original 2006/07 target of was reduced from 1,876m to 1844m to reflect the actual result for 2005/06 which at 1,816m was below the target of 1,824m for the year, and the revised modelling assumptions following new surveys of under 16 patronage.</p> <p>Further growth of just under 1% is forecast for 2007/08 in the current Business Plan. The increase in bus passenger journeys will result from:</p> <ul style="list-style-type: none"> • The continuing additional journeys made by 16/17 year olds in full time education from September 2006 who are eligible for free travel • A slight increase in journeys from the introduction of the Western Extension of the Congestion Charging Zone. <p>The effects of the 2007 fares revision, the Under 16s free travel initiative and the continuing switch from bus seasons to travelcard seasons will continue to be monitored. The target for 2007/8 is based on the current methodology for capturing passenger journeys, which is being revised to take account of passengers under 5 and other groups currently not captured.</p>				

BV165 Pedestrian crossings with facilities for disabled people	2005/06 Actual	2006/07		2007/08 Target
		Target	Actual	
The percentage of pedestrian crossings with facilities for disabled people, as a proportion of all crossings in the local authority area	64.1%	67%	29%	50%

Comment on Performance

BVPI 165 measures 'Fair Access' and the definition has been changed three times in recent years (for 2002/03, 2005/06 and again in March 2006 to revert to the 2002/03 definition). Last year's Best Value Performance Indicator report outlined the effect of these changes, and confirmed that TfL intended to continue with detailed surveys being undertaken to create a comprehensive database of all crossings on the TLRN which would be continuously updated so that not only could BVPIs be reported robustly, but areas where facilities needed to be updated to improve accessibility could also be more easily identified.

The change of definition in 2002/03 detailed more precise requirements of criteria to be met at crossings, in line with DfT Guidance on Inclusive Mobility. The current BVPI definition allows some latitude in respect of crossings installed before the revised indicator came into operation on 1 April 2002, which has been relied upon in the past to classify as 'compliant' some crossings that do not meet the strictest criteria. (The ambiguity in interpretation may also explain TfL's apparent low performance figures in comparison with the national average of 83%). However, the TLRN carries relatively high volumes of traffic and, in line with Accessible London objectives, it is considered imperative that all crossing facilities should meet the highest practical standards of compliance. After the approval of the BVPP in June 2006 the decision was taken to apply the stricter standards to the measurement of compliance, and a new survey commissioned accordingly. It is not therefore possible to directly compare the target with the actual performance, however during the year 271 individual crossings were upgraded.

As at the end of March 2007 29% of all crossings (either 'stand alone' or complete junctions as per BVPI definition) met the highest criteria of provision using the revised methodology. There are a number of crossings where only relative minor improvements are needed to bring the crossing up to compliance standards, and a programme of these has been identified for implementation in 2007/08, which in conjunction with other planned crossing work accounts for the substantial increase to 50% compliance.

TfL has ongoing concerns with the methodology for measuring performance for this indicator and is planning to commission a review to clarify the requirements of those people with disabilities in a pedestrian environment in London.

TfL continues to ensure that all new crossing facilities on the TLRN and those funded by TfL through Local Implementation Plans (LIPs) now meet BV165 accessibility standards.

BV187 Condition of surface footway	2005/06 Actual	2006/07		2007/08 Target
		Target	Actual	
Percentage of category 1, 1a and 2 footway network (TLRN) where structural maintenance should be considered.	18%	17%	20.5%	23%
<p>Comment on performance</p> <p>As part of the TfL Investment Programme and the 'Step Change' initiative of Street Management, TfL focused on improving the condition of footways on the TLRN in 2005/06, which resulted in a substantial reduction in footways reported as defective and a corresponding improvement in this indicator.</p> <p>This indicator is based on the collection and analysis of Detailed Visual Inspection (DVI) measurements, using the national Rules and Parameters for UKPMS. It is designed to provide the percentage length of the footway network with a Footway Condition Index greater than a defined threshold value. The threshold of 20.0 is indicative of the need for an investigation to determine whether maintenance is needed to preserve the footway serviceability.</p> <p>However, not only is this indicator relevant only for approximately 60% of our network, as it only applies to category 1a, 1 and 2 footways, it is potentially misleading, as it indicates the percentage of footway <i>in need of investigation to determine whether maintenance is required</i> to preserve the footway serviceability not the <i>actual</i> condition of the footway.</p> <p>Therefore although the proportion of footway in need of investigation was larger than at the end of 2006/7, and worse than target, this does not necessarily correspond to an increase in the level of footway in need of repair.</p> <p>In 2006/07, TfL introduced its own local indicator measuring the percentage of all footway network with a threshold value of 50.0 or above (i.e. in need of major repair). For 2006/07, this value was only 6%, and in part the missing of the target on the proportion in need of investigation (as above) reflected a re-prioritisation of resources away from footway work and towards road carriageway maintenance, resulting in a corresponding improvement in the condition of that asset (using the DVI method, see BV 223 on page 9). The need to re-prioritise was also in part due to the change in maintenance contracts at the end of 2006/7, which necessitated the completion of all outstanding works, accelerating some carriageway expenditure and diverting it away from footway reconstruction.</p> <p>TfL's performance is slightly better than the average of 24% for all authorities.</p>				

BV215a Rectification of street lighting faults – Non DNO	2005/06 Actual	2006/07		2007/08 Target
		Target	Actual	
The average number of days taken to repair a street lighting fault, which is under the control of the local authority	12.5	12.5	6.16	7

Comment on performance

BV215a measures lighting faults that are the responsibility of TfL, whereas BV215b requires the same information for those failures which are the responsibility of the distribution network operator (DNO) i.e. the utility companies.

The total BV 215a value includes all street lighting on the TLRN. However, TfL has adopted a risk-based approach to maintenance of street lights and focuses on lighting failures on those parts of the TLRN with relatively high pedestrian usage where lighting is (or is perceived to be) a safety issue for pedestrians and other road users (Category A-C faults). This is separated out from lighting failures in those areas where the loss of lighting represents less of a hazard, and which includes high-masted lights and those on higher speed roads where individual lamp repairs are too disruptive to traffic (Category D faults).

The reported 2006/07 value of 6.16 days comprise Category A-C faults: 4.4 days and Category D faults: 28.6 days.

A target of 12.5 days was set as this year's target because, as a new indicator for 2005/06, there were no comparable results available from other highway authorities nor any other trend data on which to base an alternative target. The target of 7 days for 2007/08 is in line with the requirements of the recently awarded Highways Maintenance Works Contracts.

TfL's performance is slightly worse than the average of 5.74 days for all authorities which is the direct result of TfL's policy regarding Category D defects.

BV215b Rectification of street lighting faults – DNO	2005/06 Actual	2006/07		2007/08 Target
		Target	Actual	
The average number of days taken to repair a street lighting fault, where response time is under the control of a DNO.	42.4	42.4	31.49	31.49

Comment on performance

BV 215b includes all street lighting faults where responsibility for time to repair is under the control of the distribution network operator (DNO) which for London, which in the main are the responsibility of EDF Energy.

TfL has little influence over the DNOs to affect their performance, although discussions with them during the year have resulted in improved performance for 2006/07. However, as DNO faults represent less than 5% of all faults this figure does not represent a significant reduction in overall street lighting service – where an average of 98.5% of street lighting has been operational throughout the year.

The target for 2007/08 has been set as the actual BV value for 2006/07.

TfL's performance is slightly better than the lower quartile of 33.77 days for all authorities.

BV223 Condition of principal roads	2005/06 Actual	2006/07		2007/08
		Target	Actual	Target
Percentage of the local authority principal road network (TLRN) where structural maintenance should be considered.	9.3%	9%	10%	8.5%
<p>Comment on performance</p> <p>SCANNER (surface condition assessment of the national network of roads) is machine based survey method, still in its infancy in terms of data interpretation. The indicator is not a measure of the network requiring investment, but an indication of where structural maintenance should be considered. Data is collected from the nearside lane, which is often difficult in London's environment.</p> <p>It was extremely difficult to set a target for 2006/7, since as discussed above, the relation between the condition of the TLRN as revealed using the SCANNER method, and maintenance intervention activities on the network, are not clear. In addition, there are methodological issues such as the need to inspect the nearside lane and maintain a constant speed, both of which are uniquely difficult on a busy network such as the TLRN. However TfL continues to use the Detailed Visual Inspection (DVI) method (which does not suffer from the limitations of the SCANNER method noted above) to monitor the entire width of the carriageway and has 5 prior years of comparable results to demonstrate improvement and to use for investment prioritisation.</p> <p>The latest DVI results showed an improvement from 6.7% in 2005/06 to 5.7% in 2006/07.</p>				

BV 99 Road Safety – Number of road accident casualties London-wide

Killed and Seriously Injured	Jan-Dec 2006/07 (Based on 2005 data)		Percentage change from Jan-Dec 2005/06 (2004) to Jan-Dec 2006/07 (2005)	Percentage change from 1994-98 average to 2005/06	2007/08 Target (For the 2006 data)
	Target	Actual			
Road User Type					
Pedestrians	1,290	1,224	-8%	-43%	
Pedal Cyclists	331	372	9%	-34%	
Powered two wheeler Riders or Passengers	839	845	-6%	-9%	
Car Drivers or Passengers	See note* ¹	989	-23%	-61%	
Other Vehicle Drivers or Passengers	See note* ¹	220	-29%	-54%	
Total	4,031	3,650	-12%	-45%	3,588

Killed and Seriously Injured	Jan-Dec 2006/07 (Based on 2005 data)		Percentage change from Jan-Dec 2005/06 (2004) to Jan-Dec 2006/07 (2005)	Percentage change from 1994-98 average to 2005/06	2007/08 Target (For the 2006 data)
	Target	Actual			
Road User Type					
Child Pedestrians	See note* ¹	241	-21%	-59%	
Child Pedal Cyclists	See note* ¹	34	-28%	-69%	
Child Car Passengers	See note* ¹	53	-40%	-73%	
Other Child Casualties	See note* ¹	27	-43%	-29%	
Total	468	355	-27%	-62%	359 (see note *³)

Slightly Injured	Jan-Dec 2006/07 (Based on 2005 data)		Percentage change from Jan-Dec 2005/06 (2004) to Jan-Dec 2006/07 (2005)	Percentage change from 1994-98 average to 2005/06	2007/08 Target (For the 2006 data)
	Target	Actual			
Road User Type					
Pedestrians	See note* ¹	4,799	-5%	-33%	
Pedal Cyclists	See note* ¹	2,523	-4%	-34%	
Powered two wheeler Riders or Passengers	See note* ¹	4,297	-8%	-16%	
Car Drivers or Passengers	See note* ¹	13,790	-7%	-29%	
Other Vehicle Drivers or Passengers	See note* ¹	2,771	-13%	-22%	
Total	See note*¹	28,180	-7%	28%	28,394 (see note *³)

BV 99 Road Safety – Number of road accident casualties London-wide

Comment on performance

Total Killed and Seriously Injured (KSI)

The full year results for 2006/07 show that the reduction in the total number of those Killed or Seriously Injured (KSI) London-wide was better than target. The total number of KSI London-wide recorded at 3,650 is 12% less than the 2005/06 total and 45% less than the 1994-98 average. It should be noted that KSIs in the first three months of the reporting year were considerably below expectations. There is a concern that this was due to under reporting by the police although there is no evidence to confirm this. The reported reduction may therefore be slightly overstated.

The target for reduction in KSI casualties across all groups by 2010 compared to the 1994-98 base average was set at 40%. However, owing to the exceptional success of road casualty reduction up to 2004, the end point targets had nearly been met six years in advance. New end point targets for 2010 were agreed. These set out reduction targets of 50% in killed and seriously injured (KSI) casualties by 2010 against the 1994-98 average across all modes both London-wide and on the TLRN. Within the modes the vulnerable road user groups, pedestrian and pedal cyclists, have a 50% reduction target, while powered two-wheelers retain a 40% reduction target. The results for 2006/07 (2005) onwards are being monitored against these new targets.

Children Killed and Seriously Injured (KSI)

The full year results for 2006/07 show that the reduction in the total numbers of Children Killed and Seriously Injured (KSI) London-wide was better than the annual target. The total number of Children KSI London-wide recorded at 355 is 27% less than the 2005/06 total and 62% less than the 1994-98 average.

The target for reduction in Child KSI casualties across all groups by 2010 compared to the 1994-98 base average was set at 50%. Exceptional success of road casualty reduction up to 2004 means a new end point target of a 60% reduction has been agreed. The results for 2006/07 (2005) onwards are being monitored against these new targets.

Slightly Injured

The full year results for 2006/07 show that the total number of slightly injured London-wide recorded at 28,180 is 7% less than the 2005/06 total and 28% less than the 1994-98 average.

The London-wide 2010 target in slightly injured across all groups was previously a 10% reduction compared to the 1994-98 base average. A new target of a 25% reduction has now been agreed. The results for 2006/07 (2005) are being monitored against these new targets.

Note *¹ : The Londonwide targets to be achieved by 2010, compared with the average for 1994-98 (which are tighter than the national targets), are for a 50% reduction in total KSI casualties, a 60% reduction in child KSI casualties, and a 25% reduction in the total slight casualty rate (expressed as number of people slightly injured per 100 million vehicle kilometres). The 25% reduction target for slight casualties applies only to the total since there are no national targets for individual categories. However, TfL retains this information for internal guidance. In addition, TfL adopted the London-wide target of a 50% reduction in KSI casualties for pedestrians and pedal cyclists and a 40% reduction for powered two wheelers to ensure attention is focused on these vulnerable user groups.

Note *² : The 2007/08 targets actually apply to the calendar year 2006 as casualty figures are reported 15 months in arrears for BV 99.

Note *³ : The 2007/08 targets for total child KSI casualties and for total slight casualties have already been exceeded by the 2006/07 results.

Corporate Health Best Value Performance Indicators

BV 2a Equality standard for local government	2005/06 Actual	2006/07		2007/08 Target
		Target	Actual	
The level of the Equality Standard for local government to which the authority conforms in respect of gender, race and disability	Level 4	Level 5	Level 4	Level 5
<p>Comment on performance</p> <p>TfL did not achieve Level 5 as originally targeted as the organisation could not fully demonstrate that it has met the required criteria as part of the assessment process. The assessment process identified gaps in the evidence provided by TfL in response to which TfL has organised a number of activities to demonstrate that it meets the required criteria to be assessed at Level 5. It is anticipated that the external assessment of TfL will be completed by Summer 2007.</p>				

BV 2b Duty to promote race equality	2005/06 Actual	2006/07		2007/08 Target
		Target	Actual	
The quality of an Authority's Race Equality Scheme (RES) and improvements resulting from its application	55%	62.5%	68.4%	79%
<p>Comment on performance</p> <p>TfL has a well established programme of activity to promote race equality and is making good progress in achieving positive outcomes for Black, Asian and Minority Ethnic (BAME) people as employees and service users. Improving the safety and security of passengers on the network through the establishment of the Transport Operations Control Unit and the increase in CCTV coverage has addressed a major concern for BAME people.</p> <p>Affordability of transport has been enhanced through the introduction of free travel schemes for children and young people and further developments to help the poorest households have benefited BAME families who are over-represented in these groups.</p> <p>The 2006/07 target was exceeded as TfL meet one of the assessment criteria a year earlier than anticipated. TfL embedded the supplier diversity requirement into major contracts and can now see the evidence of the supplier diversity agenda through contractor action plans.</p> <p>During 2007 TfL will review its RES and publish a new RES and action plan in March 2008 and plans for the involvement of BAME people in its development are already in place which will require TfL to consult with both staff and external stakeholders. As a result, TfL has set its 2007/08 target at 79%.</p>				

BV 8 Percentage of invoices paid on time	2005/06 Actual	2006/07		2007/08 Target
		Target	Actual	
Percentage of undisputed invoices for commercial goods and services paid by the Authority within 30 days of receipt or within agreed payment terms.	85%	86%	89.5%	88%
<p>Comment on performance</p> <p>TfL Group has achieved the cumulative result of 89.5% of undisputed invoices paid within agreed terms for financial year 2006/07. Following the implementation of a Shared Service Centre for TfL in September 2004, there has been steady progress across all modes and there have been additional process improvements implemented in 2006/07 which contributed to the improved result. The most important of these was the go-live of "Electronic Invoicing" which reduced processing time and increased accuracy. This has led to continuing improvement on last year and TfL has exceeded this year's target.</p> <p>TfL's performance is below the average of 92% for all authorities, but above the average for London Boroughs at 86.9%, a more appropriate comparator reflecting the size of TfL.</p>				

BV 11a Top 5% of earners : women	2005/06 Actual	2006/07		2007/08 Target
		Target	Actual	
Percentage of top paid 5% of authority staff who are women	16.72%	18.3%	20.22%	21.3%
<p>Comment on performance</p> <p>Following a third consecutive year on year improvement TfL has exceeded its target for the second year in a row. This is partly due to the overall percentage of female staff across TfL increasing to 23.3%.</p> <p>However, TfL's performance is below the average of 41.39% when compared to London boroughs, but better than the average of 18.73% for the more comparable Passenger Transport Authorities, reflecting good performance in a marketplace traditionally dominated by men.</p> <p>TfL has a number of objectives in place to improve these results going forward:</p> <ul style="list-style-type: none"> • Attract an increasing number of female applicants into operational and technical roles, • Improving retention by making TfL an employer of choice where women want to stay and have access to career development, and to roles in senior management, • Flexible working by making sure it is part of TfL's culture in helping women achieve a work-life balance, • Equal pay by ensuring there is no pay gap between men and women, • Making TfL a workplace that is free from discrimination, and • Continue to attract women to senior positions in the organisation. 				

BV 11b Top 5% of earners : ethnic minorities	2005/06 Actual	2006/07		2007/08 Target
		Target	Actual	
Percentage of top paid 5% of authority staff who are from an ethnic minority.	9.92%	10.9%	11.78%	12.3%
<p>Comment on performance</p> <p>TfL continues to be a strong 'brand' for attracting workforce from ethnic minority communities. This and focused advertising in BAME media have led to a third year of improvement, and for the second year in a row, TfL has exceeded its target.</p> <p>Given the overall percentage of BAME staff employed at TfL is 33.6%, the organisation is taking action that will improve the balance of BAME representation at senior level within the organisation and includes:</p> <ul style="list-style-type: none"> • Ensuring appropriate representation on the TfL mentoring scheme – phase 1 had 48% BAME participation and at the end of 2006/7 phase 2 will be rolled out, • Coaching programme, • Providing for secondment opportunities, and • Roll out of the leadership programme across TfL. <p>TfL's performance is slightly below the average of 11.86% for London boroughs.</p>				

BV 11c Top 5% of earners : with a disability	2005/06 Actual	2006/07		2007/08 Target
		Target	Actual	
Percentage of top paid 5% of authority staff who have a disability.	4.73%	5.0%	4.49%	5.1%
<p>Comment on performance</p> <p>Disability status is monitored in the organisation through self declaration by staff. In accordance with Best Value guidelines, the number of disabled people is reported as a percentage of those who have declared their status and not as a percentage of the whole organisation.</p> <p>The decline in the percentage of disabled staff was largely caused by an increase in the number of people who have provided information on their disability status. There has been a 3% increase in the number of staff responding to the most recent survey whereas the actual number who declared having a disability remained the same.</p> <p>TfL is continuing to review policies and procedures associated with recruiting of disabled people and ensuring that the working environment encourages their development and retention.</p> <p>TfL's performance is not only above the average of 3.58% for London Boroughs but represents better than the upper quartile performance of 4.30%.</p>				

BV 12 Working days lost due to sickness absence	2005/06 Actual	2006/07		2007/08 Target
		Target	Actual	
The number of working days/shifts lost to the Authority due to sick absence All Staff	13.05	11.6	11.70	11.0
Operational Staff	15.82	13.8	14.46	13.8
Non-Operational Staff	7.82	7.5	6.91	6.5

Comment on performance

TfL's overall sickness performance at 11.70 days represents a 10% reduction on the previous year though is marginally above the 2006/07 target.

Operational sickness levels although worse than target have fallen for the first time since the new reporting methodology was introduced in 2003/04. In Surface Transport, Dial-A-Ride experienced attendance issues as it went through reorganisation and the implementation of a new software system. Operational attendance in London Underground improved significantly compared to the previous year and only narrowly met its target.

In the Underground there is a HR Senior Business Partner with the role of 'Attendance Champion' who reports weekly to Service Directors on attendance. In addition, a 'persistent sickness handling' project is underway that identifies those who are habitually sick and considers the measures which can be implemented to address these issues.

Non-operational sickness levels have fallen for the third year in a row and for the first time are better than target.

It is not easy to make comparisons for operational and non-operational results, as this split is unique to TfL and is not published by other authorities. TfL's overall performance is worse than the average of 10.47 days for the Passenger Transport Authorities but will be affected by the proportion of operational / manual roles in TfL. However, the level of non-operational absenteeism at 6.91 days represents upper quartile performance when compared to the London Boroughs.

BV 14 Percentage of early retirements	2005/06 Actual	2006/07		2007/08 Target
		Target	Actual	
Percentage of employees retiring early (excluding ill-health retirements) as a percentage of the total workforce	0.36%	0.50%	0.26%	0.4%
Comment on performance				
<p>The 2006/07 target was set at 0.5% in recognition of the level of performance sustained from 2004/05 into 2005/06 but reflected the level of planned organisational change. However, despite the level of change, TfL's performance has continued to improve. This is mainly due to TfL working pro-actively to ensure staff that are affected by organisational change are found suitable alternative work within the organisation.</p> <p>The TfL Pension Fund is an attractive scheme and allows for voluntary early retirement, however, the organisation remains optimistic it can meet the 2007/08 target although this is determined by the demographics of the workforce and their aspirations.</p> <p>TfL's overall performance is better than the average for the London Boroughs of 0.45%</p>				

BV 15 Percentage of ill health retirements	2005/06 Actual	2006/07		2007/08 Target
		Target	Actual	
Percentage of employees retiring on the grounds of ill-health as a percentage of the total workforce All Staff	0.57%	0.6%	0.60%	0.6%
Operational Staff	0.67%	0.7%	0.76%	0.7%
Non-Operational Staff	0.38%	0.4%	0.33%	0.4%
Comment on performance				
<p>TfL's overall performance is worse than target due to higher than anticipated ill-health retirements amongst operational staff. In London Underground, better management of long term sickness cases has contributed to the increase of ill health retirements, whereas the operational areas of Surface Transport have experienced greater difficulty in redeploying staff with health problems as there is a lack of alternative operational roles and individuals often lack the skills required for non-operational posts.</p> <p>TfL's overall performance is worse than the average of 0.23% for the London Boroughs. However, it is difficult to make a true comparison due to the predominance of operational staff and safety critical roles within TfL, which does not apply to other local authorities.</p>				

BV 16 Percentage of employees with a disability	2005/06 Actual	2006/07		2007/08 Target
		Target	Actual	
The percentage of authority employees with a disability	7.66%	8.5%	7.21%	8.0%
Compared with the percentage of the economically active population in the authorities area who have a disability. ²	12.7%	-	12.7%	
<p>Comment on performance</p> <p>Disability status is monitored in the organisation through self declaration by staff. In accordance with Best Value guidelines, the number of disabled people is reported as a percentage of those who have declared their status and not as a percentage of the whole organisation.</p> <p>The decline in the percentage of disabled staff was partly caused by an increase in the number of people who have provided information on their disability status, which were disproportionately not disabled.</p> <p>The TfL Disability Equality Scheme was published in December 2006 includes activities to improve access to employment for disabled people, including a review of recruitment practices and promoting opportunities to disabled applicants, through targeted advertising and working with organisations of and for disabled people. The establishment of the Independent Disability Advisory Group in 2006 has provided TfL with additional expertise in addressing some of the historic barriers faced by disabled people in employment.</p> <p>TfL's performance is above the upper quartile figure of 4.23% for London Boroughs.</p>				

BV 17 Ethnic minority representation in the workforce	2005/06 Actual	2006/07		2007/08 Target
		Target	Actual	
The percentage of authority employees from ethnic minority communities	32.87%	28% or above	33.62%	29% or above
Compared with the percentage of the economically active population in the authorities area who are from ethnic minority communities	27.7%	-	29% ³	
<p>Comment on performance</p> <p>TfL continues to maintain a workforce well above the percentage of economically active minority communities in the authority area, which currently stands at 29%, and above the average of 26.2% for London Boroughs. Recruitment performance has again been particularly strong in this area during the year.</p>				

² Source: 2001 Census Standard Table ST106

³ Source: Office for National Statistics, Annual Population Survey 2005 (Jan – Dec)

BV 156 Buildings accessibility to people with a disability	2005/06 Actual	2006/07		2007/08 Target
		Target	Actual	
The percentage of authority buildings open to the public in which all public areas are suitable for, and accessible to, disabled people. ⁴	32.5%	33.6%	33.0%	34.7%

Comment on performance

This indicator includes TfL's portfolio of buildings within its control and includes both operational and non-operational buildings. TfL's overall performance of 33.0% against a target of 33.6% reflects a slight overrun in achieving one additional step-free access station on London Underground (Morden) which will be achieved early in 2007/08.

- London Underground which serves 275 stations has a programme of activity to increase the number of accessible stations from the current 16.7% to 25% by 2010, and to 33% by 2013.
- TfL currently uses 45 bus stations in the Greater London area and since last year has completed an upgrade on one (Finsbury Park) with plans to upgrade a further two (Hammersmith and Hounslow) in 2007/08. There are plans to construct a new bus station (Edmonton Green) in 2007.
- There are a total of 38 stations on the DLR, all of which are accessible and suitable for disabled people.
- TfL also manages 5 other properties which are open to the public. These include head office buildings, London Transport Museum (LTM), Victoria Coach Station and the Museum Archive. Of these 3 are accessible. LTM is due to re-open during 2007 and will add to the number of accessible properties.

It must be emphasised that in relation to Part 3 of the DDA, TfL has had an established practice since 1999, in any 'fit-out' and refurbishment upgrade projects, of ensuring that existing facilities, e.g. toilets, are upgraded to allow universal use and to assist in our duties under the Approved Document to Part M of the Building Regulations in force at the time (1999 and 2004 being the relevant editions). Additionally, renewals of building services and systems, e.g. fire alarms and PAs, also include the requirements of Approved Document to Part M of the Building Regulations.

In relation to emergency egress issues under BS 5588, Part 8, e.g. installation of disabled refuges, TfL adopts a risk based approach, with specific Personal Egress Emergency Plans (PEEPs) being developed on an individual basis.

TfL's performance of 33.0% is significantly below the average of 82.09% for Passenger Transport Authorities. However, this comparator is not representative since other authorities do not have operational buildings, and TfL is unique in its challenge to improve the accessibility of the London Underground system.

⁴ The assessment was carried out using Building Regulations Approved Document M, 2004 version

Best Value User Satisfaction Surveys

TfL is required to report on Best Value Performance Indicator surveys carried out by the London Boroughs on a three-yearly basis to collect data for satisfaction performance in relation to local transport information (BV102) and local bus services (BV103).

BV103 – Satisfaction with public transport information					
% satisfied	2000-01	2003-04	Change 2000-01 to 2003-04	2006-07	Change 2003-04 to 2006-07
London Boroughs	47	51	+4	60	+9
Metropolitan Boroughs	54	53	-1	57	+4
National average	47	50	+3	54	+4
Comment on performance					
Levels of satisfaction with public transport information have increased nationally however, performance in London has both exceeded the absolute level and is also improving at a faster rate.					
The figure for London is above the national top quartile percent of 59.5.					

BV104 – Satisfaction with local bus services					
% satisfied	2000-01	2003-04	Change 2000-01 to 2003-04	2006-07	Change 2003-04 to 2006-07
London Boroughs	49	58	+9	69	+11
Metropolitan Boroughs	58	57	-1	61	+4
National average	50	54	+4	60	+6
Comment on performance					
Customer satisfaction with bus services in London continues to improve at a rate above the Metropolitan Boroughs average and the national average. Satisfaction in London in 2006/07 was 9 points higher than that of the national average and is also above the national top quartile percent of 68.					

TRANSPORT FOR LONDON

BOARD

SUBJECT: Mayoral Direction to TfL in relation to fares

MEETING DATE: 27 June 2007

1. Purpose

- 1.1 To inform the Board of a Direction from the Mayor to TfL regarding the reduction of Oyster Pay-as-you-go single fares on buses and trams, and the cost of weekly bus passes from 30 September 2007.

2. Background

- 2.1 Under TfL's Standing Order No. 1 paragraph 18, TfL is required to report any Directions from the Mayor to a Board meeting as soon as reasonably practicable. A copy of the Direction issued by the Mayor on 18 June 2007 is attached to this paper.

3. The Mayor's Direction

- 3.1 In order to implement additional fares revision, the Mayor has directed TfL to reduce Oyster Pay-as-you-go fares on buses and trams from 100p to 90p and reduce the cost of weekly bus passes from 1400p to 1300p. The cost of these proposals is estimated as £36m over a full financial year, which is broadly equivalent to the revenue surplus for 2006/07. The fares proposals will come into effect on 30 September 2007.
- 3.2 The reduction to the cost of the weekly bus pass will result in a consequential reduction in the cost of the monthly and annual bus passes, as these are based on a multiple of the cost of the weekly pass.

4. Recommendation

- 4.1 The Board is requested to **NOTE** the receipt of the Direction from the Mayor.

Meeting: TfL Board Meeting

Date: 27 June 2007

Title: Mayoral Direction to TfL in relation to Fares

Version: 1

Author	Amrapali MacDonald Public Law Associate Lawyer	
Sponsor	Howard Carter General Counsel	
For queries please contact	Amrapali MacDonald	Tel: 020 7126 4090

Mayor's Office

City Hall
The Queen's Walk
London SE1 2AA
Switchboard: 020 7983 4000
Minicom: 020 7983 4458
Web: www.london.gov.uk

Peter Hendy
Transport Commissioner
Transport for London
Windsor House
42/50 Victoria Street
London
SW1H 0TL

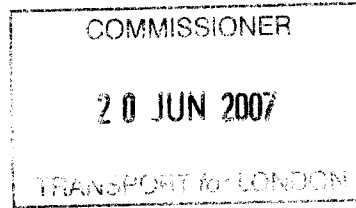

Date: 18 JUN 2007

I, KEN LIVINGSTONE, MAYOR OF LONDON, in exercise of the powers conferred on me by section 155(1)(c) of the Greater London Authority Act 1999 ("the Act") and in pursuance of my duty under section 174 of the Act, hereby direct Transport for London that the level and structure of fares to be charged for public passenger transport services provided by Transport for London or by any other person in pursuance of an agreement or in pursuance of a transport subsidiary's agreement shall from 30 September 2007 be in accordance with the conditions attached hereto.

Dated this day 18th of June 2007.

KEN LIVINGSTONE
MAYOR OF LONDON

ANNEX A

Bus and Tram tickets

	Adult price		Change	Change
	Current	Sep-07	(£)	(%)
7 Day Bus Pass				
All zones	14.00	13.00	-1.00	-7.1
Bus Oyster 'pay as you go' fare				
Any journey	1.00	0.90	-0.10	-10.0

Monthly bus season prices are 3.84 * 7-Day price (rounded up to 10p multiples). Annual season prices are 40 * 7-Day price

TRANSPORT FOR LONDON

BOARD

SUBJECT: FINANCE COMMITTEE REPORT

MEETING DATE: 27 JUNE 2007

1. PURPOSE

To report to the Board on matters discussed at the Finance Committee meeting on 7 June 2007.

2. BACKGROUND

The Committee received a paper updating it on the Best Value legislation which applies to TfL and seeking its approval for TfL's Best Value Performance Plan (BVPP) prior to publication as required by 30 June 2007. The BVPP is made up of the Business Plan which the Board approved last October together with an Annex, which principally contains the outturn Best Value Performance Indicators (BVPIs) for 2006/7 with associated commentary and comparison. The Committee had a number of observations on the BVPIs and the associated commentary and it was agreed that the Annex would be revised for these comments before submission to the Board. A paper on the BVPP enclosing the revised Annex appears as a separate item on the agenda.

The Finance Committee receives reports on approvals expected to be given in 2007/8 by the Commissioner (or in his absence, the Managing Director, Finance and Planning) for projects budgeted to cost between £25m and £100m (£10m and £25m for unbudgeted projects). Two projects had been approved since the Committee's last meeting, namely to authorise the expenditure necessary to proceed with the Low Emission Zone for lighter HGVs, buses and coaches and, secondly, to develop and supply a new type of radio for use on the new stock being ordered for the Victoria Line and the Sub-Surface Railway.

The next regular meeting of the Finance Committee will take place on 14 September 2007.

3. RECOMMENDATION

The Board is asked to NOTE the contents of this report.

TRANSPORT FOR LONDON

BOARD

SUBJECT: AUDIT COMMITTEE REPORT

MEETING DATE: 27 JUNE 2007

1. Purpose

- 1.1 The purpose of this paper is to report to the Board on the proceedings of a routine meeting of the Audit Committee held on 15 June 2007. The principal agenda item for this meeting was the review of the Annual Report and Accounts which are also being presented to the Board at today's meeting.

2. Background

- 2.1 The Audit Committee confirmed that a training session will be held on the afternoon of September 12 after the next scheduled Audit Committee meeting and confirmed that other Board members will be invited to attend should they so wish.
- 2.2 The Committee received a progress report on Strategic Risk Management and in particular noted the planned training for TfL staff on this topic and noted that this item had been added to the Audit Committee training agenda.
- 2.2 The report on Management Actions completed from audit reports was noted and it was agreed that the Committee will consider in September whether the cut-off point for reports to be made to the Audit Committee should be reduced to 30 days from the present 60.
- 2.3 The report on Final Audit Reports Issued was noted and satisfactory progress was reported on the one outstanding item. The Committee also noted the Quarter 4 Productivity and Resources report.
- 2.4 The Director of Internal Audit presented the Internal Audit Annual Report for 2006/07 which is a document required by the Code of Practice for Internal Audit in Local Government in the United Kingdom. The Director reported a clean audit opinion on the control systems within TfL based on the internal audit work completed during the course

of the year. The report also noted the progress with completion of the audit plan for 2006/07; the other work done by the department in addition to the issue of reports, reported on the development of control self-assurance, summarised the work done by the fraud prevention, detection and investigation team and summarised the resources used by the department in completing its work. The Committee noted that the department does not meet TfL's targets for equality and diversity and were told that the Director of Internal Audit is considering ways in which this can be addressed whilst recognising that this is a small team with a low turnover rate. The Committee also noted the summary of customer feedback forms received during the year and was assured that action is taken to address any negative feedback that is received.

2.5 The Committee then considered the proposed wording for the Statement of Assurance on Corporate Governance, which is included within the Statement of Accounts presented elsewhere on this agenda, and also considered the report from General Counsel and the Director of Internal Audit on the adequacy and effectiveness of the Code of Corporate Governance within TfL and compliance therewith. The Committee noted that some of the individual "commitments" included within the Code of Corporate Governance will never be assessed as green (i.e. full compliance) as it is not always possible to be assured of 100% compliance in all areas. It was also noted that CIPFA/Solace, who publish the Guidance on Corporate Governance for local government, have released a revised requirement and a presentation will be made to the September meeting explaining how this will impact TfL.

2.6 The Audit Committee reviewed:

- a paper from the Chief Finance Officer enclosing a draft of the Statement of Accounts;
- a report from KPMG on the audit of the accounts and accounting policies. KPMG's annual audit of the TfL Group is substantially complete, subject to finalisation of their value for money work which was expected to be concluded by the time of the Board meeting. They further reported that they expect to give an unqualified audit report on the accounts;
- The Committee noted that the public inspection period for the accounts had started on 31 May 2007. It was noted that the external auditor may receive questions from electors in London from 28 June regarding the accounts.

- The Committee requested that in future years members should be sent a draft of the Statement of Accounts no later than the start of public inspection to allow members more time to review and comment on it.

The report from KPMG outlined areas where significant accounting judgement has been required in preparing the accounts, which principally related to the provisions referred to above. KPMG reported that they were satisfied that management have made appropriate estimates, provisions and disclosures within the constraints of the commercial sensitivities around these claims. The highlights memorandum also reported that there were no unadjusted differences which had arisen from the audit.

In line with previous years and auditing standards, KPMG will be seeking management representations from the directors of subsidiary companies in respect of the relevant subsidiary's accounts and a representation letter from the Chief Finance Officer in respect of the Statement of Accounts.

- 2.8 The Committee received routine reports from the external auditors on independence and objectivity and on their non-audit fees for the 6 months ended 31 March 2007. The Audit and Inspection Plan for the year ended 31 March 2008 for TfL Corporate was also presented for consideration.
- 2.9 At the end of the meeting the Committee members met in private session with the external auditors.

3. Recommendation

- 3.1 The Board is requested to NOTE the content of this report.

Meeting: TfL Board
Date: 27 June 2007
Title: Audit Committee Report
Version: 1

Author	Mary Hardy	Signature of author
Sponsor	Judith Hunt	Signature of sponsor
For queries please contact	Mary Hardy	020 7126 3022