



PUBLISHED PROJECT REPORT PPR639

Construction logistics and cyclist safety

Technical report

E Delmonte, J Manning, S Helman, D Basacik, J Scoons, J Chappell, J Stannard, M Jones, I Knight

Prepared for: Transport for London (TfL)

Quality approved:

J Stannard
(Project Manager)



S Helman

G Coley

A Parkes

(Technical Referees)



Disclaimer

This report has been produced by the Transport Research Laboratory under a contract with Transport for London (TfL). Any views expressed in this report are not necessarily those of Transport for London (TfL).

The information contained herein is the property of TRL Limited and does not necessarily reflect the views or policies of the customer for whom this report was prepared. Whilst every effort has been made to ensure that the matter presented in this report is relevant, accurate and up-to-date, TRL Limited cannot accept any liability for any error or omission, or reliance on part or all of the content in another context.

When purchased in hard copy, this publication is printed on paper that is FSC (Forest Stewardship Council) and TCF (Totally Chlorine Free) registered.

Contents amendment record

This report has been amended and issued as follows:

Version	Date	Description	Editor	Technical Referee
1	21.9.12	First draft for client review	ED	SH
2	18.10.12	Second draft incorporating client comments	ED	SH/AP
3	7.12.12	Final draft	ED	JS
4	15.1.13	Final report for publication	ED	SH

Table of Contents

Executive summary	11
Abstract	18
1 Introduction	19
2 Analysis of collision and exposure data	21
2.1 What is a construction vehicle?	21
2.1.1 Goods vehicles	22
2.1.2 Construction plant	23
2.1.3 Comparison vehicles	24
2.1.4 Conclusion based on vehicle descriptions	24
2.2 Risk analysis	24
2.2.1 Exposure to risk	25
2.2.2 Collisions	31
2.2.3 Contributory factors	40
2.2.4 Analysis of risk	41
2.3 Vehicle specifications	42
3 Literature review	44
3.1 Background information	44
3.2 Literature search findings	44
3.2.1 Literature search method	44
3.2.2 Existing reviews of cyclist and HGV collision research	45
3.2.3 The extent of existing research into construction vehicles	45
3.2.4 Headline findings	46
3.2.5 Blind spot mirrors	47
3.2.6 Work-related road safety	48
3.3 Review of current guidance and activities	48
3.3.1 Guidance provided by organisations/associations	48
3.3.2 Construction Design and Management Regulations	51
3.3.3 FTA Cycling Code (2011)	51
3.3.4 Driver CPC (Certificate of Professional Competence) syllabus	52
3.3.5 Croydon Council Code of Practice	53
3.4 Overall findings from literature review and implications for research design	54
4 Safety issues relating to vehicle routing and delivery restrictions	55

4.1	Purpose of Construction Logistics Plans and their role within the Transport for London 'London Freight Plan'	55
4.1.1	Progress made to date in CLP design – generic output	55
4.1.2	Croydon Council development of CLPs	56
4.2	London Borough of Croydon CLP template	57
4.2.1	Supply chain management	57
4.3	Examples of CLPs in use in Croydon	59
4.3.1	General findings	59
4.3.2	Content of exemplar road safety orientated CLPs	60
4.4	Sample of best practice examples of CLP use outside of Croydon	60
4.4.1	General findings	60
4.4.2	Content of exemplar road safety orientated CLPs – external to Croydon	61
4.5	Conclusions	61
5	Direct and indirect visibility assessment	63
5.1	Mirror classifications	63
5.2	Visibility assessment process	65
5.3	The visible and non-visible zones for each vehicle	72
5.3.1	DAF CF Mixer (Cemex Vehicle)	72
5.3.2	DAF CF Tipper (Cemex Vehicle)	78
5.3.3	MAN TGM26 Curtain side (Dooley Rumble Vehicle)	83
5.4	Comparison of the visibility zones	87
5.5	The potential of being able to 'see' a cyclist	92
5.5.1	DAF Mixer	93
5.5.2	DAF Tipper	96
5.5.3	MAN Curtain side	98
5.5.4	Comparison of cyclist position assessment	101
6	Driver behaviour	103
6.1	Method	103
6.2	Cognitive task analysis	104
6.2.1	Description of the task	104
6.2.2	Human errors	105
6.2.3	Factors that affect the likelihood of error	107
6.3	Comments and conclusions	109
7	Construction site interviews	111
7.1	Method	111
7.2	Findings	111
7.2.1	The general structure of construction site networks	111

7.2.2	Construction Site 1	113
7.2.3	Construction Site 2	121
7.2.4	Construction Site 3	126
7.2.5	Comparison of general haulage and construction contracts	132
7.2.6	Summary of interview findings	136
8	Findings	139
8.1	General findings	139
8.2	Contractual and operational practices	140
8.3	Drivers and vehicles	143
9	Recommendations	146
9.1	Raising the profile of work-related road safety	146
9.2	Improving work-related road safety management in the construction industry	147
9.3	Making construction vehicles and journeys safer	148
9.4	Making construction vehicles and journeys safer	148
9.5	Data improvements	150
9.6	Ownership of recommendations	151
9.7	Limitations, and general considerations for future research	151
	References	153

List of figures

Figure 1: Trend in killed and seriously injured pedal cyclists for GB (from Stats19) and London (TfL, 2011b).....	32
Figure 2. Goods vehicles involved in small two wheeled collisions (source: TNO, November 2001).....	46
Figure 3: Classification and description of the mirrors discussed and assessed in this project. The image is of the DAF Tipper lorry	63
Figure 4: The Class V convex side close proximity mirror fitted to the MAN Curtain side lorry showing the distortion in the image to the straight line of the nearside side window frame where it appears curved in the image.....	64
Figure 5: The images show the internal view towards the nearside of the lorries, showing the four mirrors fitted on the nearside. The DAF mixer image shows the internally mounted front projection mirror.....	65
Figure 6: Comparison of the driver seating and eye position and the position of the steering wheel mounted laser assessment tool (DAF Tipper).....	66
Figure 7: The steering wheel mounted laser assessment tool and the rotating mount to simulate the eye	67
Figure 8: Point cloud images of the DAF Mixer, DAF Tipper and MAN Curtain side lorries.....	68
Figure 9: The direct view through the windscreen and side window for the DAF Mixer lorry and a photograph showing the A-pillar and mirror obstructions	69
Figure 10: The visibility zones for the indirect (mirror) views for the DAF Tipper lorry..	70
Figure 11: Demonstration that an object can be visible in both direct and indirect visibility	71
Figure 12: Image to show the mirrors reducing the 'blind spot' area at the front nearside corner of the MAN curtain side lorry. The light grey section of the cylinder is not visible in any view	71
Figure 13: Image showing the effect of the 'step' shape in the window frame on the shape of the visible zone on the ground	72
Figure 14: The lower and side boundaries of the visibility zones of the DAF Mixer measured from the windscreen (purple), nearside side window (brown) and the rear window in the cab (blue), the light grey sections of the cylinders are all directly visible.....	73
Figure 15: The lower and side boundaries of the indirect visibility zones of the DAF Mixer for the plain rear view mirror (green) and the wide angle rear view mirror (red). The whole boundary of the side close proximity mirror (orange) and the nearside and lower boundary of the front projection mirror (cyan)	73
Figure 16: The visibility zones mapped on an area at ground level for the nearside half of the DAF Mixer vehicle (grey area of ground not visible).....	74
Figure 17: The images show a combination of the ground coverage and three dimensional modelling of the visibility areas for the rear view mirrors (top images) and the windscreen and nearside side window (bottom images) of the DAF Mixer	75
Figure 18: A photograph of the forward projection mirror fitted internally in the DAF Mixer showing that the front of the vehicle is not visible. The model shows the effect of the mirror being fitted rearwards of the front of the cab	76

Figure 19: Image showing a 0.3m diameter cylinder positioned directly in front of the lorry and the height with which it could be to remain hidden from view in the front projection mirror 77

Figure 20: The position of the nearside side mirrors and the obstruction caused by them and the metal protective cover 78

Figure 21: The lower and side boundaries of the direct visibility zones of the DAF Tipper measured from the windscreen (purple), nearside side window (brown) and the rear window in the cab (blue). The dark green enclosed plane is the obstruction in the direct view caused by the nearside mirrors 79

Figure 22: The lower and side boundaries of the indirect visibility zones of the DAF Tipper for the plain rear view mirror (green) and the wide angle rear view mirror (red). The whole enclosed boundary of the side close proximity mirror (orange) and the whole enclosed boundary of the front projection mirror (cyan) 79

Figure 23: The visibility zones mapped on an area at ground level for the nearside half of the DAF Tipper vehicle (grey area of ground not visible)..... 80

Figure 24: The images show a combination of the ground coverage and three dimensional modelling of the visibility areas for the rear view mirrors (top images), the windscreen, nearside side window and rear window (middle images) and the side close proximity and front projection mirrors (bottom images) of the DAF Tipper..... 81

Figure 25: A photograph of the view through the rear window of the DAF Tipper and the visibility zone through the window shown on the model 82

Figure 26: The photograph shows the gap between the plain rear view mirror (top) and the wide angle rear view mirror (bottom) on the DAF Tipper 82

Figure 27: The effect of the obstruction caused by the mirrors on the nearside shown as the dark green zones. The light grey section of the cylinder is the only section that would be visible in this position between the two mirrors..... 83

Figure 28: The lower and side boundaries of the direct visibility zones of the MAN Curtain side measured from the windscreen (purple) and the nearside side window (brown). The dark green enclosed plane is the obstruction in the direct view caused by the nearside mirrors..... 83

Figure 29: The lower and side boundaries of the indirect visibility zones of the MAN Curtain side for the plain rear view mirror (green) and the wide angle rear view mirror (red). The whole enclosed boundary of the side close proximity mirror (orange) and the whole enclosed boundary of the front projection mirror (cyan) 84

Figure 30: The visibility zones mapped on an area at ground level for the nearside half of the MAN Curtain side vehicle (grey area of ground not visible) 85

Figure 31: The images show a combination of the ground coverage and three dimensional modelling of the visibility areas for the rear view mirrors (top images), the windscreen, nearside side window and rear window (middle images) and the side close proximity and front projection mirrors of the MAN Curtain side 86

Figure 32: The nearside mirrors that were found to cause an obstruction to the view through the nearside side window of the MAN curtain side lorry 87

Figure 33: The ground level visibility coverage area assessed over an area of 4m to the nearside of the vehicle, replicating a road lane width to the nearside 89

Figure 34: Simple example of the effect of a higher vehicle on the position that the ground first becomes visible 90

Figure 35: The area of ground that is visible in the front projection mirror between the front of the DAF Mixer and the first point the ground is visible through the windscreen, highlighted by the yellow border line..... 91

Figure 36: The three dimensional model of the cyclist used for the assessment. The cyclist is 1.5m tall when sitting on the bicycle 92

Figure 37: The positions of the cyclist considered during the assessment, the two rows of cyclists are 1m and 3m away from the nearside of the vehicle respectively 93

Figure 38: The cyclist in position 7 showing that for the DAF Mixer the top of the head only is visible of a cyclist 1.5m tall..... 95

Figure 39: The cyclist in position 10, showing that a proportion of the cyclist is visible in the windscreen, close proximity and front projection mirrors for the DAF Mixer. 96

Figure 40: The 1.5m tall cyclist in position 9 showing the small area of forehead that is potentially visible in the lower nearside corner of the windscreen of the DAF Tipper . 98

Figure 41: The cyclist in position 7 showing that for the MAN Curtain side lorry the upper half of the head only is visible of a cyclist 1.5m tall 100

Figure 42: Hollnagel's basic cyclical model of human action (from Hollnagel 2005) 104

Figure 43. General construction site network structure..... 112

Figure 44. Construction Site 1 interviewee network structure..... 114

Figure 45. Weekly summary of Site 1 deliveries etc. 120

Figure 46. Construction Site 2 interviewee network structure..... 121

Figure 47. Subcontractor safety questionnaire 123

Figure 48. Construction Site 3 interviewee network structure..... 127

List of tables

Table 1. Findings and associated recommendations	17
Table 2: Construction vehicle types	22
Table 3. Comparison of goods vehicle traffic in London and GB (2008).....	25
Table 4: Goods moved by HGVs on journeys to, from and within London by vehicle type, 2008 (million tonne-kilometres and proportion by vehicle type and weight). Source: UoW (2011).....	26
Table 5: Goods lifted by HGVs on journeys to, from and within London by vehicle type, 2008 (million tonnes and proportion lifted by vehicle type and weight). Source: UoW (2011)	27
Table 6: Goods lifted by HGVs to, from and within London by type of commodity, 2008 (thousand tonnes) (source: UoW, 2011)	29
Table 7: Total number of GB registered rigid goods vehicles over 3.5 tonnes in 2011 by gross weight and body type, in thousands (source: DfT, 2011b)	30
Table 8: Collisions 2008–2011 where a pedal cyclist was killed or seriously injured, with severity ratios.....	32
Table 9: All pedal cyclist casualties from collisions where at least one pedal cyclist was killed or seriously injured (2008-2011)	33
Table 10: Vehicles involved in collisions where a pedal cyclist was killed or seriously injured by collision severity (2008-2011)	33
Table 11: Goods vehicles and OMVs involved in collisions with fatally or seriously injured pedal cyclists (2008-2011)	35
Table 12: Manoeuvres of Goods vehicles and OMVs in collisions where a cyclist was killed or seriously injured (2008-11).....	36
Table 13: HGVs and OMVs in collisions with fatally and seriously injured pedal cyclists by body type (2008-11).....	37
Table 14: HGVs and OMVs in collisions with fatally and seriously injured pedal cyclists by gross vehicle weight (2008-11)	37
Table 15: HGVs and OMVs in collisions with fatally and seriously injured pedal cyclists by axle configuration (2008-11).....	38
Table 16: HGVs and OMVs in collisions with fatally and seriously injured pedal cyclists by axle configuration and body type (2008-11).....	39
Table 17: HGVs and OMVs in collisions with fatally and seriously injured pedal cyclists by junction type and body type (2008-11)	39
Table 18: HGVs and OMVs in collisions with fatally and seriously injured pedal cyclists by vehicle manoeuvre and body type (2008-11)	40
Table 19: Number of KSI pedal cyclist collision involved vehicles (in London) per thousand licenses (in GB) for selected body types	42
Table 20: The areas of visible ground coverage within an area measuring 16m x 18m for the DAF Mixer lorry	75
Table 21: The areas of visible ground coverage within an area measuring 16m x 18m for the DAF Tipper lorry	80

Table 22: The areas of visible ground coverage within an area measuring 16m x 18m for the MAN Curtain side lorry..... 85

Table 23: The areas of visible ground coverage within an area measuring 16m x 18m for the three assessed lorries..... 88

Table 24: The areas of visible ground coverage for a representative lane one when the assessed vehicle is in lane two 89

Table 25: A summary of the cyclists that would be visible (wholly or a proportion thereof) for each viewing component of the DAF Mixer. The cyclist was 1.5m tall in this assessment 93

Table 26: A summary of the cyclists that would be visible (wholly or a proportion thereof) for each viewing component of the DAF Tipper. The cyclist was 1.5m tall in this assessment 96

Table 27: A summary of the cyclists that would be visible (wholly or a proportion thereof) for each viewing component of the MAN Curtain side lorry. The cyclist was 1.5m tall in this assessment 99

Table 28: The collated results of the assessment of the cyclists that would be visible (wholly or a proportion thereof) for each viewing component of the three assessed lorries. The cyclist was 1.5m tall in this assessment 102

Table 29: Driver errors that could lead to a collision between a HGV and cyclist..... 106

Table 30: Factors which may affect the likelihood of human errors leading to HGV-cyclist crashes 108

Table 31. Typical level of ownership of construction vehicle driver’s safety by different stakeholders, on-site and off-site (for secondary subcontractor level driver) 136

Executive summary

Background

One of the Mayor's objectives is to bring about a significant increase in cycling in London, with a target that it accounts for at least 5% of modal share by 2026 (Greater London Authority, 2011). Cycling is seen as a mode of transport to be encouraged within London because of the health and traffic congestion benefits it brings, and the number of cyclists in London is increasing. The improvement of cyclist safety is seen as a key priority for TfL, as concerns about safety are a barrier to increasing cycling levels further.

Detailed analysis of cyclist fatalities has shown that of the 16 in 2011 in London, nine involved a heavy goods vehicle (HGV), and seven of these were construction vehicles. Given that the construction industry is responsible for only a small proportion of freight traffic in GB and London this suggests that construction vehicles may be overrepresented in cyclist fatalities in London.

TfL has therefore commissioned TRL to undertake research aimed at understanding the following general themes around this issue:

1. Is it possible to understand the relative risk represented by construction vehicles to cyclists, when compared with general haulage vehicles? If so, what is it? What are the limitations in the data available?
2. Are there features of contractual arrangements, working practices, driver behaviour, or vehicle design (or combinations of these) that contribute to the apparent over-involvement of construction vehicles in fatal collisions with cyclists in London?

The research also aimed to identify measures that could be implemented to help reduce the number of such collisions.

The current report provides a technical report of the research carried out and gives detail on the methods used, the data gathered, and the supporting evidence that give rise to these findings and recommendations the resulting recommendations. A summary report (Helman, Delmonte & Stannard, 2012) provides a concise summary of the research carried out and the resulting recommendations.

Methods

The project employed six largely concurrent streams of research:

- An analysis of collision and exposure data which attempts to define what a 'construction vehicle' is and the collision risk (with cyclists) of vehicles relating to the construction industry.
- A review of existing literature relating to collisions between HGVs/construction vehicles and cyclists, as well as literature relating to work currently being undertaken within the UK to reduce risk.
- An overview of safety issues relating to vehicle routing and delivery restrictions, focusing on Construction Logistics Plans and their role within TfL's London Freight Plan.

- Laser scans of two construction vehicles, and one general haulage vehicle for comparison, to investigate the direct and indirect visibility available to drivers.
- Three observational drives (two in construction vehicles, one in a general haulage vehicle for comparison) to inform a task analysis and to analyse the errors that drivers could make which might lead to a collision with a cyclist.
- Interviews with 27 individuals involved in one of three London construction sites (from subcontracted drivers to clients), as well as seven individuals involved in construction and general haulage (for comparison) but not directly related to the sites visited. These interviews improved understanding of how the various individuals and organisations in a given network perceive the issues associated with vulnerable road user safety, as well as investigating contractual practices, recruitment, remuneration etc.

Findings

Eleven key findings emerged from the research (two general findings, and nine specific).

General findings

General finding 1: Road risk is viewed as less important than general health and safety risk (see recommendations 1, 2 and 3)

At the operational level the construction industry does not ascribe road risk the same level of importance as general health and safety risks when selecting who to work with, and when managing safety performance.

General finding 2: Although road casualty statistics make it difficult to identify industry sectors associated with collisions, construction traffic appears likely to be over-represented in collisions with cyclists (see recommendation 11)

This is likely to be due to differences in the features of the routes that construction and general haulage vehicles drive, the vehicles themselves, and the types of journey in which they are engaged.

Specific findings

Specific finding 1: There is a lack of ownership of road risk by clients and principal contractors in the construction industry (see recommendations 3, 4, 5, 8 and 9)

There is limited ownership of road risk within the construction industry by clients and principal contractors. This stands in contrast to the ownership of health and safety risk on site.

Specific finding 2: Data on collisions and near misses on the road are not generally collected on construction projects (see recommendations 1, 3, 4 and 5)

Statistics relating to on-road collisions are generally excluded from an organisation's overall safety statistics. Safety statistics are often inspected during contractor procurement, but the key concern is on-site collisions. Driver safety, particularly off-site, does not generally appear to be considered.

Specific finding 3: Evidence suggests that there is a lack of awareness about road risk in the construction industry (see recommendations 1, 2, 3, 4, 5 and 9)

Despite the wide publicity that the issue of cyclist collisions with large vehicles has received, the levels of awareness of the issue in the construction industry in London appear to be low.

Specific finding 4: The Fleet Operator Recognition Scheme (FORS), and Construction Logistics Plans (CLPs), are existing mechanisms that might be used to manage road risk in the construction industry; however they are not used as widely or as seriously as might be hoped (see recommendations 5 and 9)

There are two existing mechanisms by which road risk might be managed in the construction industry; these are FORS and CLPs. Although these are used, there are shortcomings in how they are used and monitored.

Specific finding 5: Delivery time slots used in the construction industry may contribute to driver pressure (see recommendations 5 and 8)

Many construction sites utilise a delivery booking system to manage arrivals to the site, whereby vehicles are assigned a time slot in which to arrive. There is clearly awareness in the industry that this can place pressure on drivers, particularly when the time slot is tight.

Specific finding 6: Route planning to avoid interactions with cyclists is especially difficult on construction projects due to the transitory nature of sites (see recommendations 5 and 9)

The transitory nature of construction sites makes route planning to avoid interactions with cyclists (the best way of avoiding collisions) challenging.

Evidence suggests that pay per load does happen in the construction industry, however no evidence was found to suggest that it is a crucial factor in collisions with cyclists (see recommendation 10)

Although some types of construction driver are paid on a per load basis, no specific evidence was found that that paying drivers in this manner changes the amount of work drivers attempt to do, or the time in which they attempt to complete the work.

Specific finding 8: Although total blind spots are likely to be rare, visibility of cyclists in some areas around construction vehicles is still poor (see recommendations 6 and 7)

The view afforded of cyclists in some positions to the left and in front of the vehicle, even with mirrors fitted to meet legal requirements and positioned by a fully qualified driver, can be poor. Some differences between the construction vehicles and general haulage vehicle examined are worthy of further investigation.

Specific finding 9: There is great potential for driver error and high driver workload in construction industry driving, and multiple changes will be needed to reduce this (see recommendations 4 to 10)

The cognitive task analysis revealed a number of points of possible failure, most of which are associated with a breakdown in visual awareness, and many of which may take place before the driver and cyclist arrive at a junction. Many of the factors identified in other

findings (for example driver pressure to meet time slots, and view from the cab) will make errors more likely.

Recommendations

Twelve recommendations are made on the basis of the findings. These are grouped under the categories of 'Raising the profile of work-related road safety', 'Improving work-related road safety management in the construction industry', 'Making construction vehicles and journeys safer', and 'Data improvements'. In addition, a final recommendation is given relating to the ownership of recommendations one to 11. Table 1 (on page 17) illustrates the connection between the findings and recommendations.

Raising the profile of work-related road safety

Recommendation 1: HSE should extend the Reporting of Injuries, Diseases and Dangerous Occurrences Regulations (RIDDOR) to include on-road collisions

This will send a clear message to businesses (including the construction sector) that road risk and general health and safety are to be treated equally. To improve the likelihood of this happening, the HSE should extend RIDDOR to include on-road collisions as a matter of urgency. It is likely that changes to RIDDOR of this magnitude will take a considerable amount of time to implement. In the shorter term, HSE could develop an Approved Code of Practice (ACoP) for work-related road safety (including the requirement to record on-road collisions), for use by all industry sectors, including the construction industry.

Recommendation 2: Adherence to a nationally recognised standard on work-related road safety (such as the ISO39001 standard on road traffic safety management) should be promoted

A new International Standard has recently been issued (ISO39001:2012). Organisations of five or more employees driving to or from construction sites within London should be required to achieve this standard, or a similar standard as determined by the industry. Consideration should be given as to how this standard would apply to companies of different sizes. TfL should extend and mandate CLP guidelines to support these activities.

Improving work-related road safety management in the construction industry

Recommendation 3: HSE should include off-site safety in the Construction Phase Plan (mandatory under the CDM regulations)

The regulations governing the construction industry, construction design and management regulations (CDM), owned by the HSE, do not require driving for work to be included in the construction phase plan (currently it only covers on-site health and safety). The HSE should mandate inclusion of off-site safety (i.e. driving for work) in the construction phase plan. Under the CDM regulations the principal contractor takes ownership of the construction phase plan and therefore, if it were included, ownership of road risk.

Recommendation 4: Existing channels should be utilised more effectively to raise awareness of road risk within the construction industry

There are many associations within the transport sector who should use their networks to improve communication of the importance of managing construction vehicle safety (including the risk they present to cyclists and other vulnerable road users) once vehicles

have left sites. These include the FORS network, Construction Equipment Association, the Construction Industry Council and the Mineral Products Association.

Recommendation 5: CLP guidance should be updated by TfL and its use promoted throughout London. CLP compliance should be monitored by TfL. This should be embedded into the planning application process for London-based construction projects

There needs to be a standard to which all organisations operating in the construction industry within London adhere to. Updated CLP guidance which is used by all London boroughs for public and private construction work should be used for this. The CLP guidance should be updated to make it more robust as a means of ensuring each construction site has a mechanism for managing road risk.

Making construction vehicles and journeys safer

Recommendation 6: Vehicle manufacturers should work to improve vehicle and mirror design

Of the vehicles examined, some had a much larger non-visible area (at ground level) than others; various aspects of vehicle design can be addressed to improve drivers' view of cyclists, and vehicle manufacturers should seek to identify and implement design improvements that might be made specifically for vehicles driving on London's streets. This could include changes to windscreen or dashboard design, as well as new technologies and improved mirror design. It is important that the introduction or modification of mirrors (or mirror configurations and combinations) does not result in an increase in driver workload; the best combination of mirrors needs to be identified which enables optimal visibility and workload. Further research will be needed to define this, in line with the following recommendation.

Recommendation 7: A wider review of the blind spots in different construction vehicle types should be conducted

The current research considered three vehicles of differing ages and produced by different manufacturers, and therefore was not representative of the range of tippers, mixers and curtain side vehicles available. A comprehensive review of vehicles used in the construction industry would greatly improve understanding of the challenges faced by drivers in relation to observing cyclists on the road. The outcome of such a review would be a business case for demonstrating the need for regulatory change in the UK or EU.

Recommendation 8: Principal contractors and clients should use more realistic delivery time slots

The use of more realistic time slots (for example by allowing vehicles arriving either side of their allocated slot to enter the site where reasonable, or use of holding bays to facilitate early arrival) would help to reduce driver pressure, and thus would help reduce driver errors. This should be included as an additional aspect to the CLPs.

Recommendation 9: CLPs must include the definition of safer routes to construction sites

As part of the mandatory CLPs, principal contractors should define safer routes to their site (within a set local radius, for example five miles), where possible avoiding risky

areas such as schools, cyclist 'hotspots', narrow roads and difficult junctions. In all cases consideration should be given to minimising exposure to vulnerable road users.

Recommendation 10: Further research should be conducted to understand the effects of pay per load contracts

Pay per load contracts are sometimes used in the construction industry, principally where owner-drivers are involved. No definitive evidence emerged in the current research to support the perception that paying a driver per load may discourage safe driving. However further research with a much larger sample is required to fully understand the current use of pay per load contracts and any effects they may have on driver behaviour.

Data improvements

Recommendation 11: The vehicle type 'construction vehicle' should be included in Stats19

This would improve knowledge of the incidence of collisions between cyclists (and other vulnerable road users) and vehicles used for construction. If possible, this should be done quickly with the involvement of the Metropolitan Police Service, or otherwise should be prioritised in the next consultation on Stats19.

Ownership of recommendations

Recommendation 12: Recommendations 1 to 11 need to be addressed by stakeholders from across the industry, working with relevant regulatory bodies when necessary

Where possible, the ownership of the previous recommendations should lie with the relevant industry stakeholders, including regulators, the construction industry, and vehicle manufacturers. Without clear ownership there is a risk that the recommendations will not be addressed; the identification and engagement of relevant key stakeholders is crucial to ensure that the recommendations are taken forward and acted on appropriately.

Limitations and general considerations for future research

The research should be seen as having identified some general and specific issues that deserve action, and in some cases that demand further investigation using more quantitative techniques on larger samples (where quantification of issues is desired). Many of these are represented in the recommendations. It is noteworthy that no previous research could be found in the literature that has addressed the specific issues associated with the construction industry and cyclist safety; this suggests that further research in the area would be timely.

Table 1. Findings and associated recommendations

Findings	Recommendations										
	1: HSE should extend RIDDDOR to include on-road collisions	2: Adherence to a nationally recognised standard on WRRS should be promoted	3: HSE should include off-site safety in the Construction Phase Plan	4: Existing channels should be utilised more effectively	5: CLP guidance should be updated by TfL	6: Vehicle manufacturers should work to improve vehicle and mirror design	7: A wider review of the blind spots in different construction vehicle types	8: Principal contractors and clients should use more realistic delivery time slots	9: CLPs must include the definition of safer routes to construction sites	10: Further research should be conducted to understand the effects of pay per load	11: 'Construction vehicle' Stats19 should be included in
General 1: Road risk is viewed as less important than general health and safety risk											
General 2: Although road casualty statistics make it difficult to identify industry sectors associated with collisions, construction traffic appears likely to be over-represented in collisions with cyclists											
Specific 1: There is a lack of ownership of road risk by clients and principal contractors in the construction industry											
Specific 2: Data on collisions and near misses on the road are not generally collected on construction projects											
Specific 3: Evidence suggests that there is a lack of awareness about road risk in the construction industry											
Specific 4: FORS and CLPs are existing mechanisms that might be used to manage road risk in the construction industry; however they are not used as widely or as seriously as might be hoped											
Specific 5: Delivery time slots used in the construction industry may contribute to driver pressure											
Specific 6: Route planning to avoid interactions with cyclists is especially difficult due to the transitory nature of construction sites											
Specific 7: Evidence suggests that pay per load does happen in the construction industry, however no evidence was found to suggest that it is a crucial factor in collisions with cyclists											
Specific 8: Although total blind spots are likely to be rare, visibility of cyclists in some areas around construction vehicles is still poor											
Specific 9: There is great potential for driver error and high driver workload in construction industry driving; multiple changes will be needed to reduce this											

Abstract

This research explored the reasons for the apparent disproportionately high involvement of construction vehicles in cyclist fatalities in London. Of the 26 cyclist fatalities that occurred in London in 2010 and 2011, 9 (35%) involved a vehicle used for construction. The purpose of the research was to identify potential measures that could be implemented to help avoid such collisions in the future. Six research activities were undertaken. These were an analysis of collision and exposure data, a literature review, an overview of safety issues relating to vehicle routing and delivery restrictions (focusing on Construction Logistics Plans), 3D scans of three vehicles to investigate the visibility of cyclist to drivers, observational drives, and interviews with individuals involved in construction sites. The key findings were that road risk tends to be viewed as less important than general health and safety risk in the construction industry, and that clients and principal contractors on construction projects tend not to take responsibility for road risk in the same way that they do for general health and safety risk. A number of more specific findings are described, along with recommendations for action.

1 Introduction

One of the Mayor's objectives is to bring about a significant increase in cycling in London; accounting for at least 5% of modal share by 2026 (Greater London Authority, 2011). Cycling is seen as a mode of transport to be encouraged within London because of the health and traffic congestion benefits it brings. In line with this aim, the number of people cycling in London is increasing; between 2000/01 and 2011/12, the cyclist flow on the Transport for London Road Network (TLRN) increased by 173% (TfL, 2012a).

The improvement of cyclist safety is seen as a key priority for TfL and data suggest that the risk of being killed or injured on a bicycle has been reducing steadily (e.g. TfL, 2010 states that there was a 107% increase in cycling flow between 2000 and 2008, compared with a 9.8% increase in cyclist casualties). However, the reduction in risk per trip has not been enough to completely offset the increased traffic, such that the total number of cyclists being injured has increased: in Greater London there were 3,506 cyclist injuries (422 killed or seriously injured) in 2000, and 4,497 (571 killed or seriously injured) in 2010 (TfL, 2012a).

TfL has also identified that the movement of goods has a crucial role to play in supporting the future growth of London's economy, and TfL's London Freight Plan (published in October 2007) identified steps to be taken to address the challenge of delivering freight sustainably in the capital. It stated that "...it is essential that freight activity is considered...to avoid generating conflict with other road users, particularly pedestrians and cyclists" (TfL, 2007, p.27).

Recent research (Keigan, Cuerden & Wheeler, 2009) used Stats19 data on 92 fatal cyclist collisions to show that 38% involved an HGV of 7.5 tonnes or over in weight. A substantial proportion of those (25%) involved a large vehicle turning left or changing lanes to the left and striking a pedal cyclist.

According to TfL, more detailed information has shown that, of the ten cyclist fatalities that occurred in London in 2010, two involved an HGV of 7.5 tonnes or over, one of which was a concrete mixing lorry and the other a skip lorry. The incident involving the skip lorry occurred when both the vehicle and the cyclist were turning left, while the collision with the mixing lorry occurred when the lorry changed lane to the left across the cyclist's path (TfL, 2011b).

Of the 16 fatalities in 2011, nine involved an HGV, and seven of these were a construction vehicle (TfL bid specification, 2011c). More detailed data support the earlier research in suggesting that HGVs over 7.5 tonnes are disproportionately involved in pedal cycle fatalities in London. Further to this it also suggests that seven of the 11 HGVs involved were trucks that could be associated with the construction industry. Given that the construction industry is responsible for only a small proportion of freight traffic in GB (see section 2), this suggests that construction vehicles are disproportionately overrepresented in cyclist fatalities in London.

TfL has commissioned TRL to undertake research aimed at understanding the reasons for this. The research aims to identify potential measures that could be implemented to help avoid such collisions in the future, by addressing the following specific research questions:

- Is it possible to define what counts as a construction vehicle in the collision data that are available? What are the data limitations? What do the most recent data suggest in terms of the scale of the problem?
- Are there aspects of the design and specification of the vehicles used by the construction industry that contribute to their apparent over-involvement in fatal collisions with cyclists?
- Are there aspects of driver behaviour in the construction industry that contribute to the apparent over-involvement of construction vehicles in fatal collisions with cyclists?
- Are there aspects of contractual or operational practices in the construction industry that contribute to the apparent over-involvement of construction vehicles in fatal collisions with cyclists?

This research involved the following key tasks:

- Defining what counts as a construction vehicle, especially in the collision data that are available
- Understanding the collision mechanisms involved
- Investigating whether the design and specification of the vehicles used by the construction industry contributes to their apparent over-involvement in fatal collisions with cyclists
- Investigating whether driver behaviour in the construction industry contributes to their apparent over-involvement in fatal collisions with cyclists
- Investigating whether contractual or operational practice within the construction industry contributes to the over-involvement of construction vehicles in fatal collisions with cyclists
- Developing proposals for measures capable of solving or mitigating the extent of any problems identified.

The work has been undertaken with input from a Technical Advisory Group, which incorporated a wide range of interested stakeholders from TfL, the freight industry, representatives of pedal cyclists, and academia.

This is the final report from this research and describes in full all methods, results and conclusions from the work. The remaining sections of the report are structured as follows:

Section 2 describes an analysis of collision and exposure data using the Stats19 database (including enhanced data), which was used to guide later work in the project.

Section 3 describes the findings from a review of the literature (including industry websites and activities) relating to construction logistics operations and interactions between HGVs and cyclists (and other vulnerable road users).

Section 4 looks wider still at vehicle routing and delivery restrictions enforced upon construction sites, or their subcontractors, and describes the development of Construction Logistics Plans (CLPs), paying particular attention to their contribution to the safety of cyclists and other vulnerable road users. The section focuses on recent and concurrent work undertaken by the London Borough of Croydon, in conjunction with TfL,

to further develop CLPs. Examples of Best Practice within the construction industry are analysed and presented within this section.

Section 5 describes the results of vehicle scanning, in which the mirror configurations on two types of construction vehicle and one general haulage vehicle were modelled to investigate what can be seen by the driver, and where blind spots exist.

Section 6 presents work that aims to build a comprehensive picture of typical driver behaviour and collision scenarios using observations of construction vehicle and HGV drivers (using the same vehicle types as in Section 0) on real drives of such vehicles. This allowed observation of the way in which drivers use their mirrors and other devices when driving the vehicle, and included a cognitive task analysis. It also considered driver distractions that may impact on the task of driving the vehicle.

Section 7 presents the outcome of interviews with stakeholders throughout networks of construction operators (logistics companies, site management companies, sub-contractors and clients) to establish whether there are contractual practices that contribute to the problem. Since collisions are not simply a driver/vehicle issue, it was important to expand the research to understand the contractual processes in place and the communication of health and safety messages that may impact on driver behaviour.

Section 8 presents the findings, and section 9 presents associated recommendations.

2 Analysis of collision and exposure data

2.1 What is a construction vehicle?

Prior to undertaking any analysis of collision and exposure data it is important that the term "construction vehicle" is clearly defined so that they may be identified in existing datasets.

There are two main categories of task in which the construction industry uses vehicles:

- To deliver construction materials to, and remove waste from, construction sites.
- To undertake construction tasks such as moving materials around sites, digging, lifting, and demolition.

The first task of delivery and collection will use goods vehicles of varying shapes and sizes. These vehicles will typically spend most of their time on the public road moving the materials they carry between their source and the construction site. However some of the vehicles can also be used for purposes other than construction. This makes it important to consider whether there are any features that help to distinguish their use predominately or exclusively in the construction industry.

The second task of involvement in the construction process itself will typically be undertaken with construction plant vehicles. These will tend to be items of machinery far more specifically designed for the construction task, though some such as cranes and telehandlers are also used in a variety of other applications. Typically, these vehicles would be expected to spend most of their time on site, occasionally travelling on public roads in order to access different parts of a site or to move between different sites when their job is completed.

Table 2 is a list of construction vehicle types, which are described in greater detail in section 2.1.1.

Table 2: Construction vehicle types

Vehicle group	Vehicle type
Goods vehicles	Tipping vehicles
	Concrete mixers
	Skip carriers
	Flat beds
	Drop sided
	Low loaders
Construction plant	Earth movers, diggers, Backhoes etc.
	Dump trucks
	Mobile cranes
	Telehandlers

2.1.1 Goods vehicles

2.1.1.1 Tipping vehicles

Typically these vehicles are used by the construction industry to transport loose materials such as aggregates to sites and/or to remove 'waste' materials such as soil removed as part of landscaping or digging foundations. However, these are also used in other applications, for example in agriculture for the transport of grain or manure. Some distinction can be made based on off-road capability. Construction vehicles are often required to load at quarries and unload on sites in a variety of sometimes poor conditions and will thus often have more than one drive axle. Many sites also prohibit articulated vehicles because of concerns about their stability during tipping operations on uneven ground. Thus, large rigid tippers, particularly those with twin drive axles (e.g. 6x4 and 8x4), are more likely to be associated with the construction industry than articulated tippers with a 6x2 tractor.

2.1.1.2 Concrete mixers

These are rigid vehicles used to transport cement and concrete products to site in a ready mixed form, and are not typically used in other industries.

2.1.1.3 Skip carriers

Skip carriers are rigid vehicles specially adapted to enable waste skips to be delivered, transported and collected. Skips are primarily used to collect waste for transport to disposal (recycling or landfill) and while the waste may often be from the construction industry it can also be domestic or from other industries. There would be nothing to distinguish a skip carrier involved in carrying waste from ones used in different industries.

2.1.1.4 Flat beds

These are used to transport a variety of construction products including large beams, pipes, roof trusses etc. They are also widely used in other industries to carry, for

example, hay bales, timber products, and machinery. Those used in construction will have few unique identifying features.

2.1.1.5 Drop sided

These are often used in construction to carry products such as bricks and blockwork, sometimes incorporating an on-board loader crane to enable delivery. They are also used as general purpose vehicles in other industries, and again it will be difficult or impossible to distinguish between these.

2.1.1.6 Low loaders

Low loaders are typically semi-trailers used as part of an articulated vehicle and characterised by small diameter wheels and a very low deck height. They are typically used in the construction industry to transport construction plant from one site to another. They also have similar uses in other industries, for example, transporting large pieces of machinery to a factory where they will be installed. Again it is not clear how those used in the construction industry would be identified.

2.1.2 Construction plant

2.1.2.1 Earth movers, diggers, Backhoes etc.

These will be equipped with a variety of beams/arms and attachments such as ploughs, buckets etc., and driver cabins can be mounted on platforms that rotate relative to the chassis.

2.1.2.2 Dump trucks

These are typically used for moving excavated material from the point of excavation to a store or a vehicle waiting to transport it away from site. Often these have a central articulation point or are steered at the rear to increase manoeuvrability in tight spaces.

2.1.2.3 Mobile cranes

These will typically have a boom overhanging the driving position and can be very large and heavy. They are specialist and expensive pieces of equipment often hired for short periods for specific jobs so will spend significant amounts of time on public roads travelling to and from different jobs. This type of crane is typically only operated when stationary and supported by hydraulic rams to ensure stability during the lift.

2.1.2.4 Telehandlers

Telehandlers are used for lifting and moving materials using a telescopic boom mounted to a vehicle. Unlike mobile cranes telehandlers can move while lifting and may have all-wheel steer to aid manoeuvrability in tight spaces. Telehandlers are also used extensively in warehousing of general freight and in agriculture and engineering.

2.1.3 Comparison vehicles

A comparison between construction vehicles and other goods or utility vehicles will also be aided by consideration of body types not typically associated with the construction industry, for example:

- Car transporters (automotive industry)
- Livestock carriers (agricultural industry)
- Refuse collectors (municipal services)
- Street cleaners (municipal services)
- Recovery vehicles (automotive industry)
- Tankers – typically carry fuel and chemicals in liquid, gas and powdered form, as well as some food stuffs such as milk, molasses etc.
- Box, curtain sided and refrigerated vehicles – typically used to transport a wide variety of freight that requires protection from the elements. This includes post, parcels and consumer goods (e.g. food, drink, consumer electronics). Large articulated vehicles are typically used for long distance transport between source (e.g. ports, factories) and national distribution centres, and between national and regional distribution centres. Smaller rigid vehicles are typically used for local distribution to retail outlets and directly to consumers. The typical density of goods moved means that it is rare for rigid vehicles to have more than 3 axles because the maximum length of rigid vehicles (12m) means that most will be filled by volume without exceeding the 26 tonne limit.

It can be seen from the range of descriptions here that the possible permutations of vehicle that could be considered in a comparison of construction vehicles with heavy vehicles used in other sectors could be considerable. A full comparison was, therefore, considered to be beyond the scope of this project. Instead, an outline assessment was undertaken of the relative risks posed by different vehicle types.

2.1.4 Conclusion based on vehicle descriptions

The definitions above suggest that a description by body type will not always be sufficient to fully segregate the vehicles used by the construction industry from those used in other economic activities.

Ideally, a description of the commodity carried would also be used but this is rarely available in existing data sources. Within each of the classifications above, it is possible to have a wide variety of sizes. For example, tippers and cement mixers can be 2, 3 or 4 axle rigid vehicles with regulatory maximum masses of approximately 18, 26 and 32 tonnes. Two-axle vehicles may also be limited to 7.5 tonnes in order to benefit from less burdensome regulations where large capacities are not required.

2.2 Risk analysis

In addition to looking at the number, cause and severity of collisions relating to the construction industry, it is worthwhile to consider the collision risk of construction vehicles relative to other vehicle types, to understand whether some vehicle types are under or over represented in certain types of collision. In order to do this, the exposure of each vehicle type to risk on the road network needs to be identified.

2.2.1 Exposure to risk

Exposure can be measured in many ways. This section considers the possible options and discusses the best measure to use to undertake risk exposure calculations.

2.2.1.1 Relative to traffic

In GB as a whole, DfT breaks its own account haulage¹ down by the type of business. In 2010 (DfT, 2011a) it was shown that the construction industry was responsible for approximately 7% of all own account traffic (vehicle km). However, it was not known what proportion of hire and reward traffic was attributable to the construction industry.

UoW (2011) showed that London is a net importer of goods² and in fact had a larger net inflow of goods than any other UK region. It was also shown that road is the dominant mode by which these goods were moved (89% of tonnes lifted³). Table 3 compares the goods vehicle traffic in London and nationally.

Table 3. Comparison of goods vehicle traffic in London and GB (2008)

	London	GB
Billion vehicle kms (BVKs) of goods vehicle traffic	5.3	96.8
% of BVKs by LGVs <3.5t	80	70
% of BVKs by rigid HGVs >3.5t	15	15
% of BVKs by articulated vehicles >3.5t	5	15

It can be seen that in London the use of rigid HGVs is in line with the rest of the country but that light vans are much more prevalent and articulated HGVs much less prevalent.

2.2.1.2 Relative to freight task

Exposure to risk is usually measured by distance travelled (vehicle km) because it can be applied equally across different vehicle types. However, the need to move goods is primarily economically driven, with only a part of this related to the vehicles available to actually move the goods. Thus, an alternative to the usual exposure measure is to measure the quantity of goods moved, usually expressed in terms of million tonne-km.

¹ 'Own account haulage' refers to where the haulier involved is transporting their own goods rather than transporting somebody else's goods for hire and reward

² In other words more goods were brought into London from outside sources than were sourced in London and shipped elsewhere

³ 'Goods lifted' is measured in terms of the weight of goods handled, taking no account of the distance they are carried, whereas 'goods moved' (measured in tonne kilometres) is the weight of the load multiplied by the distance it is carried.

Table 4: Goods moved by HGVs on journeys to, from and within London by vehicle type, 2008 (million tonne-kilometres and proportion by vehicle type and weight). Source: UoW (2011)⁴

Gross vehicle weight and type	Journey type			
	Within London	To London	From London	To, from and within London
Over 3.5 to 7.5t	118 (10%)	113 (2%)	57 (2%)	288 (3%)
Over 7.5 to 17t	105 (9%)	72 (1%)	51 (1%)	228 (2%)
Over 17 to 25t	166 (14%)	269 (5%)	239 (7%)	674 (6%)
Over 25t	562 (46%)	516 (9%)	539 (16%)	1,617 (16%)
All rigid⁵	952 (78%)	970 (17%)	886 (26%)	2,808 (27%)
Over 3.5 to 33t	41 (3%)	191 (3%)	131 (4%)	363 (3%)
Over 33t	220 (18%)	4,589 (80%)	2,447 (71%)	7,256 (70%)
All articulated⁶	261 (22%)	4,780 (83%)	2,577 (74%)	7,618 (73%)
All vehicles⁷	1,213 (100%)	5,750 (100%)	3,464 (100%)	10,427 (100%)

In terms of measuring the exposure to risk of a collision in London, the above data are imperfect because only a proportion of the tonne km identified for journeys to and from London will actually occur within London, and this proportion is unknown. Including all journeys identified in Table 4 will significantly over-estimate the exposure to risk in London; including only the journeys with both origin and destination in London would significantly underestimate exposure. To estimate the freight movement on London's roads only would require a disaggregate freight model capable of mapping origin and destination data onto a digital road map and using shortest path and/or minimum time algorithms to estimate the likely route taken and then count only the proportion of these journeys that occurred within London boundaries. Such an exercise was beyond the scope of this project.

An alternative measure would be to consider only the tonnes lifted on journeys to, from and within London, as shown in Table 5.

⁴ Note that in the tables in this report, percentages do not always total 100%. This is due to rounding.

⁵ Including rigid vehicles of unknown gross weight

⁶ Including articulated vehicles of unknown gross weight

⁷ Including vehicles of unknown weight and type

Table 5: Goods lifted by HGVs on journeys to, from and within London by vehicle type, 2008 (million tonnes and proportion lifted by vehicle type and weight). Source: UoW (2011)

Gross vehicle weight and type	Journey type			
	Within London	To London	From London	To, from and within London
Over 3.5 to 7.5 t	4 (7%)	1 (2%)	1 (2%)	6 (4%)
Over 7.5 to 17 t	4 (7%)	1 (2%)	1 (2%)	6 (4%)
Over 17 to 25 t	8 (13%)	3 (5%)	3 (8%)	13 (9%)
Over 25 t	34 (58%)	9 (17%)	9 (29%)	52 (36%)
All rigid	50 (85%)	14 (26%)	13 (42%)	76 (54%)
Over 3.5 to 33 t	1 (2%)	2 (3%)	1 (4%)	4 (3%)
Over 33 t	8 (13%)	36 (71%)	18 (55%)	61 (43%)
All articulated	9 (15%)	38 (74%)	19 (58%)	65 (46%)
All vehicles	58 (100%)	51 (100%)	32 (100%)	142 (100%)

This measure does not account for the distance driven. However, if the portion of the journeys 'to London' (and 'from London') that actually occurred within London was the same length, on average, as the journeys that occur solely 'within London', then the total tonnes lifted in Table 5 would be an accurate measure of the exposure to risk of a collision in London.

The data on which the analyses above are based (UoW, 2011) come from the Department for Transport's Continuing Survey of Road Goods Transported (CSRGT). This source of data contains no information on body type (e.g. tipper/box) which was identified in the previous section as one of the ways in which it might be possible to identify construction vehicles. It should also be noted that it only includes data on the goods vehicles, as defined in section 2.1 above, and not the construction plant equipment.

Table 5 does contain information on the gross vehicle weight (GVW). However, the published data only breaks this down into the categories shown, which are based around regulatory mass limits that are no longer in force. It used to be that for rigid vehicles, the maximum permitted mass for 2 axle rigid vehicles was approximately 17 tonnes, for 3 axle rigid vehicles 24.5 tonnes and for 4 axle rigid vehicles approximately 30.5 tonnes. Thus the categorisation above would relate closely to the number of axles and it would be possible to state with confidence that the category of over 25 tonnes would relate to a 4 axle rigid vehicle, which anecdotally at least, would give a strong indication that it was some form of construction vehicle because the most common type of 4 axle rigid are tippers and cement mixers etc. However, the maximum masses were changed early this century such that the maximum permitted mass for a 3 axle vehicle is now 26 tonnes and would thus fall into the final category. Three axle box or curtain sided rigids are also common so the same assumptions can no longer be made. The raw CSRGT data, which is held by DfT's statistics branch, has been sampled based on new weight groups but the published results are categorised in relation to the old ones for reasons of comparability. This implies that it may be possible to infer more about 4 axle rigids typically used in construction from the raw CSRGT data, if made available, but this was beyond the scope of this analysis.

An additional method of analysing construction traffic as a proportion of all traffic is to consider the commodity carried. The data contained in CSRG and analysed by UoW (2011) allows the commodities carried by goods vehicles travelling to, from and within London to be studied based on standard categorisations. The results are shown in Table 6.

Allocating these commodities to industry segments requires a degree of interpretation. Those commodities likely to be related to the construction industry are highlighted in blue in Table 6. It is clear that "other building materials" and "cements" will be almost solely attributable to the construction industry.

It is reasonable to state that a minimum of approximately 15% of all tonnes lifted on journeys to, from and within London are associated with the construction industry.

However, it is also reasonable to assume that a large proportion of "sand gravel and clay" and "other crude minerals" will also be associated with construction. Although some of these latter two commodities will be associated with other industries, it is also likely that small proportions of other categories may arise from the construction industry.

A reasonable upper estimate of construction industry traffic in London would be 33% of tonnes lifted by HGVs. DfT (2009) produced the same statistics for the same year but for the whole of GB. The same commodities represented approximately 28% of all goods lifted in GB.

It would appear that the exposure to risk of construction vehicles is slightly greater in London than it is for GB as a whole.

Table 6: Goods lifted by HGVs to, from and within London by type of commodity, 2008 (thousand tonnes) (source: UoW, 2011)

Commodity type	Journey type							
	Within London		To London		From London		To, from and within London	
Food, drink and tobacco								
Agricultural products	777	1%	1,797	4%	1,230	4%	3,804	3%
Beverages	918	2%	1,542	3%	1,874	6%	4,334	3%
Other foodstuffs	4,130	7%	10,763	21%	2,352	7%	17,245	12%
Subtotal	5,825	10%	14,102	28%	5,456	17%	25,383	18%
Bulk products								
Wood, timber and cork	530	1%	361	1%	316	1%	1,207	1%
Sand, gravel and clay	4,979	9%	1,774	3%	1,857	6%	8,550	6%
Other crude minerals	11,188	19%	3,518	7%	2,884	9%	17,590	12%
Ores	188	0%	177	0%	374	1%	739	1%
Crude materials	262	0%	235	0%	512	2%	1,009	1%
Cements	8,245	14%	1,008	2%	-	0%	9,253	7%
Other building materials	4,971	9%	4,411	9%	2,570	8%	11,952	8%
Iron and steel products	85	0%	884	2%	225	1%	1,194	1%
Subtotal	30,388	52%	12,368	24%	8,738	27%	51,494	36%
Chemicals and petrol								
Petrol and petroleum products	675	1%	4,173	8%	187	1%	5,035	4%
Chemicals	180	0%	1,720	3%	189	1%	2,089	1%
Subtotal	855	1%	5,893	12%	376	1%	7,124	5%
Miscellaneous products								
Other metal products	907	2%	1,018	2%	389	1%	2,314	2%
Machinery and transport equipment	1,501	3%	2,712	5%	2,515	8%	6,728	5%
Miscellaneous manufactures	2,022	3%	3,815	7%	1,961	6%	7,798	6%
Miscellaneous articles	16,743	29%	11,276	22%	12,878	40%	40,897	29%
Subtotal	21,173	36%	18,821	37%	17,743	55%	57,737	41%
All commodities	58,242	100%	51,184	100%	32,314	100%	141,740	100%

2.2.1.3 Relative to number of vehicles

Where ideal exposure measures are not available, another proxy is the number of registered vehicles. The limitation again is that this does not consider the fact that different vehicle types that appear to have equal exposure to risk based on the number of vehicles registered may in fact differ because one type is typically driven for longer distances, or with different loads. The number of GB registered goods vehicles that are also taxed as goods vehicles (excluding those where the maximum weight is unknown) is shown in Table 7, below.

Table 7: Total number of GB registered rigid goods vehicles over 3.5 tonnes in 2011 by gross weight and body type, in thousands (source: DfT, 2011b)

Body type	Up to 7.5 tonnes	Over 7.5 tonnes up to 15 tonnes	Over 15 tonnes up to 18 tonnes	Over 18 tonnes up to 26 tonnes	Over 26 tonnes	Total	Percentage of all vehicles >3.5 tonnes
Box van	46.5	8.3	12.3	2.5	0.2	69.8	25.1%
Tipper	16.8	1.2	3.9	4.5	14.6	40.9	14.7%
Curtain sided	10.8	2.2	10.3	5.7	0.2	29.2	10.5%
Dropside lorry	10.1	1.9	4.6	3.5	0.2	20.3	7.3%
Flat lorry	6.5	1.6	3.3	5.4	1.4	18.2	6.5%
Refuse disposal	0.9	1.1	1.6	10.9	1.6	16.2	5.8%
Insulated van	5.4	2.7	4.1	2.2	0.1	14.4	5.2%
Skip loader	1.0	0.6	5.6	1.1	3.4	11.7	4.2%
Tanker	0.4	0.5	2.3	2.8	1.3	7.3	2.6%
Panel van	7.0	0.0	0.1	0.0	0.0	7.2	2.6%
Goods	2.5	0.8	1.1	1.3	0.7	6.4	2.3%
Street cleansing	2.2	2.4	0.4	0.1	0.0	5.1	1.8%
Livestock carrier	3.5	0.3	0.1	0.2	0.0	4.2	1.5%
Car transporter	1.1	0.4	0.9	1.4	0.2	4.0	1.4%
Concrete mixer	0.0	0.1	0.4	1.9	1.3	3.7	1.3%
Tractor	0.2	0.1	0.3	0.7	2.0	3.2	1.2%
Tower wagon	1.6	0.1	0.0	0.0	0.0	1.8	0.6%
Skeletal vehicle	0.5	0.3	0.4	0.3	0.3	1.8	0.6%
Luton van	1.3	0.1	0.1	0.0	0.0	1.5	0.5%
Special purpose	0.4	0.2	0.3	0.2	0.1	1.2	0.4%
Specially fitted van	0.6	0.2	0.2	0.1	0.0	1.1	0.4%
Van	0.9	0.1	0.0	0.0	0.0	1.1	0.4%
Other	3.2	1.1	1.6	1.0	0.6	7.5	2.7%
Total	123.6	26.5	53.8	45.9	28.1	278.0	100%

Those body types highlighted in section 2.1 as being particularly associated with the construction industry have been highlighted in blue. The data exclude articulated vehicles because there is no requirement to register a trailer in the UK and some of the descriptions (e.g. low loader) are not separately identified.

Based on the data presented, it would appear that the vehicle types strongly related to construction represent 20% of all rigid goods vehicles in GB. This could be increased to approximately 28% if dropsided vehicles were included in the definition, but a significant proportion of these could be associated with other industries.

Within this, tipper vehicles are by far the most prevalent, representing approximately 73% of all those in the construction industry group. The most prevalent type of tipper is a small one, up to 7.5 tonnes GVW, closely followed by very large ones of more than 26 tonnes in GVW.

Construction plant equipment vehicles are not required to be registered as road vehicles and as such no exposure data are readily available.

2.2.1.4 Summary

It can be seen that London relies heavily on freight. Its use of rigid HGVs is in line with the rest of the country but proportionally it makes greater use of light vans and less use of articulated HGVs. Although the traffic in terms of vehicle km is dominated by light vans, with only a small contribution by articulated vehicles, the greater load carried by articulated vehicles means that in terms of freight movement (tonne km) the distribution is reversed.

When rigid HGVs are considered in particular, it can be seen that about a third of all goods lifted on journeys to, from and within London are commodities that would be associated with the construction industry. This is greater than would be the case in GB as a whole (33% compared with 28%), suggesting that the construction industry is responsible for a greater proportion of the exposure to risk in London (represented by rigid vehicles) than the average for GB. Nationally, vehicle body types that would typically be associated with construction make up around 20% to 28% of all rigid HGVs registered.

2.2.2 Collisions

Analyses were undertaken using the enhanced Stats19 database of road injury collisions to identify which vehicle types were involved in collisions which resulted in fatal or serious injury to cyclists, and the manoeuvres being undertaken when the collisions occurred.

2.2.2.1 Analysis of enhanced Stats19 data for London

The trend in killed and seriously injured pedal cyclists over the whole of Great Britain (extracted from Stats19) is shown in Figure 1 together with the same trend for London (TfL, 2011b). It can be seen that the two trends are similar, although the London values are more variable.

Both trends were lowest in 2004 and KSI pedal cyclists in London made up the smallest proportion of all KSI pedal cyclists in this year (14%). Since 2004, the number of pedal

cyclists killed or seriously injured has generally been rising, both inside and outside of London, with both 2010 figures being the highest since 1999.

KSI pedal cyclist casualties within London formed the highest proportion of all KSI pedal cyclists in 2003 when they accounted for 18% of KSI pedal cyclists within Great Britain.

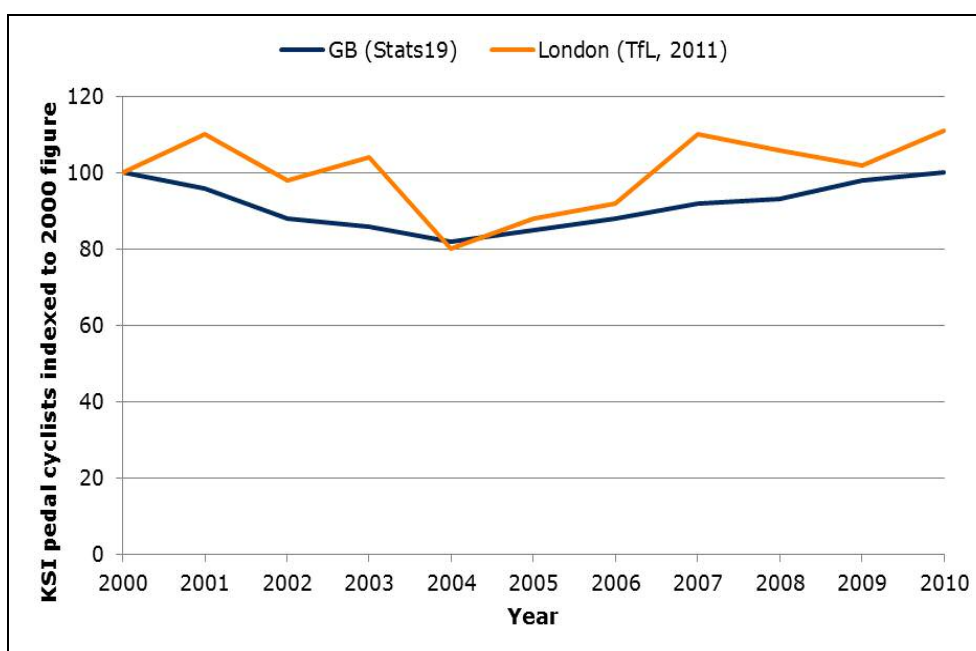

Figure 1: Trend in killed and seriously injured pedal cyclists for GB (from Stats19) and London (TfL, 2011b)

Stats19 collision data for inner London were extracted from the AccStats database held by TfL for 2008–2011, including enhanced vehicle data. The enhanced vehicle data provide additional information on body types, gross vehicle weight and axle configurations to that held in the standard Stats19.

Table 8 shows the number of collisions between 2008 and 2011 where at least one pedal cyclist was killed or seriously injured. The proportion of such collisions in which at least one cyclist was fatally injured fell each year between 2008 and 2010 and then increased again in 2011.

The 1,911 collisions involving a killed or seriously injured pedal cyclist resulted in 1,924 pedal cyclist casualties, eight of which were slightly injured. These pedal cyclist casualties are shown in Table 9.

Table 8: Collisions 2008–2011 where a pedal cyclist was killed or seriously injured, with severity ratios

Year	Fatal	Serious	Total	% Fatal
2008	15	429	444	3.4%
2009	13	419	432	3.0%
2010	10	456	466	2.1%
2011	16	553	569	2.8%
Total	54	1,857	1,911	2.8%

Table 9: All pedal cyclist casualties from collisions where at least one pedal cyclist was killed or seriously injured (2008-2011)

Year	Fatal	Serious	Slight	Total
2008	15	430	3	448
2009	13	420	0	433
2010	10	457	2	469
2011	16	555	3	574
Total	54	1,862	8	1,924

Table 10 shows the vehicles involved in collisions where a pedal cyclist was killed or seriously injured. These 1,911 collisions involved 1,933 pedal cycles and 1,825 vehicles of other types.

There were 72 goods vehicles of more than 7.5 tonnes and 32 'other motor vehicles' involved in collisions that resulted in fatal or serious injury to a pedal cyclist; 32% of these goods vehicles and 22% of 'other motor vehicles' were involved in collisions where the pedal cyclist was killed.

Table 10: Vehicles involved in collisions where a pedal cyclist was killed or seriously injured by collision severity (2008-2011)

Vehicle Type	Fatal	Serious	Total	% Fatal
Pedal Cycle	54	1,879	1,933	3%
Motorcycle	1	49	50	2%
Car (inc. taxi)	20	1,342	1,362	1%
Minibus (8-16 Pass)		4	4	0%
Bus/Coach	4	91	95	4%
Agricultural Vehicle		1	1	0%
Goods vehicle =< 3.5t	3	175	178	2%
Goods vehicle 3.5-7.5t	1	28	29	3%
Goods vehicle => 7.5t	23	49	72	32%
Other Motor Vehicle	7	25	32	22%
Other Non Motor Vehicle		2	2	0%
Total	113	3,645	3,758	3%

Due to the high prevalence of goods vehicles over 7.5 tonnes and 'other motor vehicles' (OMVs) in fatal pedal cyclist collisions these collisions are studied further.

2.2.2.2 OMVs

TfL has also indicated that they wish to consider construction equipment, as described in section 2.1, within the scope of the analysis. Within the national accident database, Stats19, these should be coded within the OMV category and should not appear within the HGV category. The basic Stats19 data does not separate construction equipment from other vehicles that are categorised as OMV such as horseboxes, military vehicles, recovery vehicles, refuse collectors, street cleaners, and emergency vehicles. Some

information can be deduced from data on the make and model collected as part of the enhanced data set and such an attempt has been reported as part of section 2.1.3.

Smith and Gard (2002) analysed collisions involving vehicles in the OMV category in more detail based on the HVCIS fatal database, which stores data extracted from police fatal accident reports, including expert crash investigation reports, post mortem reports, specialist vehicle examiner reports, witness statements and photographs. This allows much more explicit identification of vehicles. Smith and Gard found by comparing the HVCIS data with Stats19 data for the same collisions, that vehicles of this type were often miscoded in Stats19. Of a total sample of 124 fatal collisions involving an OMV where the police report was analysed for the work, the vehicle involved had been wrongly classified as an OMV in 31 cases, almost half of which should have been coded as HGVs. This left a residual sample of 93 OMVs. Thirty-nine of these (42%) were agricultural vehicles and six were agricultural machines. It should be noted that in subsequent years agricultural vehicles have been allocated their own dedicated vehicle category in Stats19 and are no longer coded as OMVs.

Of the types that would now be considered an OMV, the sample contained a total of 48, of which there were:

- 9 recovery vehicles
- 7 horseboxes
- 5 ambulances
- 4 fire appliances
- 4 refuse collectors
- 3 mechanical diggers*
- 3 cranes*
- 3 forklifts*
- 3 gully cleaners
- 1 other construction machinery*
- 1 dump truck*
- 1 hydraulic platform*
- 1 armoured security vehicle
- 1 ice cream van
- 1 quad bike
- 1 tram

A maximum of 12 of these could be considered to be construction vehicles (marked with an asterisk above), though the cranes, forklifts and hydraulic platform could also have been attributed to other industries.

In total, considering all 93 OMVs in the sample, there were four that resulted in pedal cyclist fatalities. These four arose from collisions involving an agricultural vehicle, a horsebox, a recovery vehicle and a refuse collector. None of these could be considered to be construction equipment.

2.2.2.3 Goods and OMV vehicle collisions with cyclists

Table 11 shows the number of goods vehicles and OMVs involved in collisions with fatally or seriously injured pedal cyclists. It can be seen that rigid vehicles were more commonly involved in collisions than articulated and towing vehicles, although this may be because rigid vehicles are more common, particularly in the cases of the smaller goods vehicles.

Table 11: Goods vehicles and OMVs involved in collisions with fatally or seriously injured pedal cyclists (2008-2011)

Vehicle Type and Tow	Fatal				Serious				Total
	2008	2009	2010	2011	2008	2009	2010	2011	
Rigid OMV		2	2	3	9	5	5	6	32
Rigid LCV⁸≤3.5t				3	44	31	44	55	177
Rigid HGV 3.5-7.5t		1			8	4	7	8	28
Rigid HGV≥7.5t	6	4	1	6	13	6	8	11	55
Articulated 3.5-7.5t							1		1
Articulated≥7.5t	3	2	1			5	3	3	17
Single LCV≤3.5t						1			1
Total	9	9	4	12	74	52	68	83	311

The analysis shows that rigid vehicles were responsible for 82% of all pedal cyclists killed by goods vehicles and other motor vehicles in London in 2008-2010 (28 out of 34 fatalities). Sixty-one per cent of these were rigid HGVs in excess of 7.5 tonnes GVW.

Table 12 shows the manoeuvres that HGVs and OMVs were carrying out when a collision with a killed or seriously injured pedal cyclist occurred.

The most common manoeuvre in such collisions was turning left (31% of all involved HGVs and OMVs).

The percentage of vehicles turning left at the point of the collision was particularly high for rigid HGVs over 7.5 tonnes GVW, 31 (56%) of the 55 HGVs over 7.5 tonnes involved in collisions with killed or seriously injured pedal cyclists were turning left at the point of the collision.

⁸ Light commercial vehicle

Table 12: Manoeuvres of Goods vehicles and OMVs in collisions where a cyclist was killed or seriously injured (2008-11)

Collision Severity	Vehicle Type and Tow	Manoeuvre																	
		Reversing	Parked	Going Ahead. Held Up	Slowing Or Stopping	Moving Off	U-Turning	Turning Left	Turning Right	Waiting To Turn Right	Changing Lane To Left	Changing Lane To Right	Overtaking Move Veh O/S	Overtaking Stat Veh O/S	Overtaking on Nearside	Going Ahead Left Bend	Going Ahead Right Bend	Going Ahead Other	Total
Fatal	Rigid OMV							4			1					1		1	7
	Rigid LCV≤3.5t								1									2	3
	Rigid HGV 3.5-7.5t							1											1
	Rigid HGV≥7.5t					2		13									1	1	17
	Articulated HGV≥7.5t					1		1	1									3	6
Serious	Rigid OMV	1	3			1		8	3				1					8	25
	Rigid LCV≤3.5t	3	22	8	9	7	2	38	37		3	2	8	3	1	2		29	174
	Rigid HGV 3.5-7.5t	1	3			3		5	3	1		1	3	1				6	27
	Rigid HGV≥7.5t			2		2		18	5		2	1	2			1		5	38
	Articulated HGV 3.5-7.5t					1													1
	Articulated HGV≥7.5t					1		7	1				1					1	11
	Single LCV≤3.5t												1						1
Total		5	28	10	9	18	2	95	51	1	6	4	16	4	1	4	1	56	311

The collisions involving a fatally or seriously injured pedal cyclist and an HGV or OMV were linked to the enhanced vehicle data to provide additional information on body types, gross vehicle weight and axle configurations.

The enhanced vehicle data are available for only a subset of vehicles in Stats19 and were not available for nine goods vehicles of between 3.5 and 7.5 tonnes, eleven goods vehicles of over 7.5 tonnes and nine other motor vehicles.

Table 13: HGVs and OMVs in collisions with fatally and seriously injured pedal cyclists by body type (2008-11)

Collision Severity	Vehicle Type	Body Type							Total
		Tipper	Skip loader	Concrete mixer	Roller	Box van	Other HGV / OMV	Unknown	
Fatal	OMV	2	1	2			2		7
	Goods 3.5-7.5t						1		1
	Goods => 7.5t	10	1			1	6	2	20
Serious	OMV	4		3	1		7	1	16
	Goods 3.5-7.5t	1		2			16		19
	Goods => 7.5t	12	3	2		1	21	2	41
Total		29	5	9	1	2	53	5	104

The most commonly recorded body type that may be a construction vehicle was Tipper, accounting for 29 out of the 104 HGVs and OMVs with known body types. (Example body types included in the category 'Other HGV / OMV' are breakdown truck, refuse disposal, panel van, goods, and tractor.)

Table 14: HGVs and OMVs in collisions with fatally and seriously injured pedal cyclists by gross vehicle weight (2008-11)

Collision Severity	Vehicle Type	Gross Vehicle Weight					Unknown / Not applicable	Total
		≤7.5 tonnes	7.5t - 15t	15t-18t	18t-26t	>26 tonnes		
Fatal	OMV			3	1	3		7
	Goods 3.5-7.5t	1						1
	Goods => 7.5t		1	2	5	11	1	20
Serious	OMV	3	1	2	1	5	4	16
	Goods 3.5-7.5t	4		2	2	8	3	19
	Goods => 7.5t	3	2	4	6	24	2	41
Total		11	4	13	15	51	10	104

Goods vehicles and other motor vehicles involved in collisions resulting in a pedal cyclist being killed or seriously injured were most commonly those with a gross weight of over 26 tonnes.

Table 15 shows the 104 OMVs and goods vehicles over 3.5 tonnes that had collisions with killed or seriously injured pedal cyclists within London 2008-11 by axle configuration. This shows that 2-axle rigid and 4+ axle rigid were the most common axle configurations, these two categories accounting for 76 (73%) of the 104 vehicles.

The most common combination of vehicle type and axle configuration was goods vehicles over 7.5 tonnes with an axle configuration of 4+ rigid.

Table 15: HGVs and OMVs in collisions with fatally and seriously injured pedal cyclists by axle configuration (2008-11)

Collision Severity	Vehicle Type	Axle Configuration									Total	
		2-wheel	3-wheel	2-axle rigid	3-axle rigid	4+ axle rigid	2-axle + artic	3-axle + artic	2+2 artic	2+3 artic		3+3 artic
Fatal	OMV			4		3						7
	Goods 3.5-7.5t			1								1
	Goods => 7.5t			4	4	10	1		1			20
Serious	OMV		1	9	1	5						16
	Goods 3.5-7.5t			9	2	3				1	4	19
	Goods => 7.5t	1		10	6	18		1			5	41
Total		1	1	37	13	39	1	1	1	1	9	104

Table 16 shows the 104 OMVs and goods vehicles over 3.5 tonnes that had collisions with killed or seriously injured pedal cyclists within London 2008-11 by axle configuration and body type. The most common combination of body type and axle configuration was tippers with an axle configuration of 4+ rigid. 26 of the 29 tippers in the sample were 4+ axle rigids.

Table 16: HGVs and OMVs in collisions with fatally and seriously injured pedal cyclists by axle configuration and body type (2008-11)

Body type	2-wheel	3-wheel	2-axle rigid	3-axle rigid	4+ axle rigid	2-axle + artic	3-axle + artic	2+2 artic	2+3 artic	3+3 artic	Total
Tipper			3		26						29
Skip loader			3		2						5
Concrete mixer				1	8						9
Roller		1									1
Box van			2								2
Other HGV / OMV	1		26	11	2	1	1	1	1	9	53
Unknown			3	1	1						5
Total	1	1	37	13	39	1	1	1	1	9	104

Table 17 shows the 104 HGVs and OMVs involved in collisions resulting in a fatal or serious injury to a pedal cyclist and with enhanced vehicle data available by body type and junction type. 40 (38%) of these 104 vehicles were involved in collisions at T/staggered junctions and 32 (31%) were involved in collisions at crossroads.

Table 17: HGVs and OMVs in collisions with fatally and seriously injured pedal cyclists by junction type and body type (2008-11)

Body type	0 No Jun In 20m	1 Roundabout	3 T/Stag Junc	5 Slip Road	6 Crossroads	7 Multi Junction	9 Other Junction	Total
Tipper	1	4	10		14			29
Skip loader			3		1	1		5
Concrete mixer	1		3		4	1		9
Roller		1						1
Box van	1		1					2
Other HGV / OMV	9	4	23	1	9	2	5	53
Unknown		1			4			5
Total	8	10	40	1	32	4	5	104

Table 17 shows, more specifically, that 48% of tippers were involved in collisions at crossroads and 34% were at T/staggered junctions. Four out of nine concrete mixers were at crossroads and three were at T/staggered junctions. Box vans had only one collision at a junction – this junction was a T/staggered junction.

Table 18: HGVs and OMVs in collisions with fatally and seriously injured pedal cyclists by vehicle manoeuvre and body type (2008-11)

Vehicle manoeuvres	Tipper	Skip loader	Concrete mixer	Roller	Box van	Other HGV / OMV	Unknown	Total
01 Reversing				1		1		2
02 Parked						4	1	5
03 Going Ahead Held Up						2		2
05 Moving Off	3		2			5		10
07 Turning Left	19	3	6		1	17	3	49
09 Turning Right	2	1				5		8
11 Change Lane To Left	1		1					2
12 Change Lane To Right						2		2
13 Overtake Move Veh O/S	1					3		4
14 Overtake Stat Veh O/S						1		1
16 Going Ahead Left Bend		1				1		2
17 Going Ahead Right Bend	1							1
18 Going Ahead Other	2				1	12	1	16
Total	29	5	9	1	2	53	5	104

Table 18 shows that 19 of the 29 tippers were turning left and three were moving off. Six of the nine concrete mixers were turning left and two were moving off. Overall HGVs and OMVs turning left and 'going ahead other' were most common.

2.2.3 Contributory factors

Of the 40 tippers, concrete mixers and box vans involved in fatal and serious pedal cyclist collisions, one of the box vans was in a collision with no contributory factors recorded. Eight of the collisions had contributory factors assigned to the pedal cyclist alone, ten had factors assigned to the tipper, concrete mixer or box van alone and the other 21 collisions had factors assigned to both the pedal cyclist and the tipper, concrete mixer or box van with which they collided. Note that vehicles may have up to six contributory factors assigned to them.

The most commonly recorded factor for tippers, concrete mixers and box vans was 'vehicle blind spot' which was recorded for fifteen of the tippers, three concrete mixers and the box van. The next most common recorded factors for these vehicles were 'failed to look properly' (recorded for nine tippers, three concrete mixers and the box van) and 'passing too close to cyclist, horse rider or pedestrian' (recorded for six tippers).

The most commonly recorded factors for the pedal cyclists in these collisions were 'failed to judge other person's path or speed' and 'failed to look properly' and which were recorded for sixteen and twelve pedal cyclists respectively. Careless, reckless or in a

hurry was recorded for seven pedal cyclists and 'poor turn or manoeuvre' was recorded for five.

The most commonly recorded factor for all HGVs / OMVs involved in collisions where a pedal cyclist was killed or seriously injured was 'failed to look properly' which was recorded for these vehicles in 56 of the 131 such accidents with contributory factors available.

The next two most commonly recorded factors for all HGVs / OMVs were 'vehicle blind spot' and 'passing too close to cyclist, horse rider or pedestrian'.

2.2.4 Analysis of risk

It is clear that light commercial vehicles of no more than 3,500kg GVW present the least risk to cyclists in left turn manoeuvres, being involved in only one such fatality in London in 12 years (representing 2.2% of all such fatalities in that time period) but being responsible for approximately 80% of all goods vehicle traffic (billion vehicle kms, based on data from 2008).

The risk per unit of distance travelled by articulated HGVs is greater, being involved in the collisions resulting in five (11%) of the relevant fatalities but only 5% of the total vehicle kilometres driven by goods vehicles in London.

However, it is clear that by far the greatest risks per unit of distance travelled are presented by rigid HGVs, being involved in 87% of the relevant fatalities, despite making up just 15% of the total goods vehicle traffic.

In the context of this analysis the risk from LCVs can be considered statistically negligible. If both the casualties and distances travelled by LCVs are excluded from the analysis then consideration of HGVs shows that rigid vehicles make up 89% of the fatalities from 75% of the distance travelled. Articulated vehicles are responsible for 11% of the fatalities from 25% of the distance driven. When the freight task is also considered this analysis becomes much more stark, with rigid vehicles involved in 89% of the fatalities but only 54% of the freight lifted (tonnes) or 27% of the freight moved (tonne km). Articulated vehicles are involved in 11% of the fatalities despite lifting approximately 46% of the freight (tonnes) or 73% of the freight moved (tonne km), on journeys to, from and within London. On the surface this would imply that moving freight from rigid vehicles to larger articulated vehicles would reduce the number of cyclists killed in left turns. However, this would ignore the possibility that within this traffic data there is a different distribution by class of road, for example, articulated vehicles may be doing a greater proportion of their total distance on relatively safe major arterial roads whereas rigid vehicles might be used more on local unclassified roads where the chances of a conflict with a cyclist may be greater. Much more detailed modelling of the routes taken by different types of HGV combined with information on cyclist flows by route would be required to evaluate this further.

The data on construction equipment suggest that the frequency of incidents involving construction equipment, as opposed to HGVs serving the construction industry, is very low. No data are available regarding the exposure of such vehicles to risk but intuitively it seems likely that the low incidence is directly related to low exposure to risk, that is, such vehicles travel on the road relatively rarely.

Table 19 shows the number of vehicles involved in a collision which resulted in fatal or serious injuries to a pedal cyclist relative to the number of licensed vehicles for selected body types. The table is affected by a number of limitations of the data:

- Vehicle registration numbers for London are not available, and so national figures have been used to provide a collision involvement rate per thousand vehicles. Clearly, the number of vehicles operating in London will be lower than the GB figures, but presuming the proportion of vehicles licensed in London is approximately the same for each vehicle type, the figures in the final column provide a good indication of the relative collision involvement of the three vehicles types (although the figures for London would actually be higher).
- Even if data were available for vehicles registered in London, this would not represent the number of vehicles driven in London (as those registered in London may be driven nationally, and vice versa).
- Data for vehicle-km driven in London, combined with collision data, would give a much more accurate description of risk by body type.

For consistency, the number of vehicles involved in fatal and serious collisions from 2008-2011 have been used, and have been divided by four to give the 'per year' figure in the final column.

Table 19: Number of KSI pedal cyclist collision involved vehicles (in London) per thousand licenses (in GB) for selected body types⁹

Body Type	Vehicles involved in fatal and serious collisions in London (2008-2011)	Thousand vehicles licensed in GB (2010)	London collision involved vehicles per year per thousand licensed in GB
Tipper	29	42.8	0.17
Concrete mixer	9	3.8	0.59
Dropside lorry¹⁰	5	20.4	0.06

The construction vehicle associated with the highest collision involved vehicle rate (per thousand licensed vehicles) is the concrete mixer. However, this is involved in fewer collisions overall because of its lower levels of use.

2.3 Vehicle specifications

The analysis shows that the construction vehicle most commonly involved in pedal cycle fatalities is a rigid tipper in excess of 26 tonnes.

⁹ The numbers of vehicles involved in collisions includes all vehicles recorded with Stats19 vehicle type HGV or 'other motor' that have enhanced vehicle data available. The number of vehicles licensed only includes heavy goods vehicles in the 'Goods' taxation class. None of the HGVs or OMVs involved in collisions with KSI pedal cyclists had taxation class 'goods' according to the enhanced vehicle data. This discrepancy remains unexplained.

¹⁰ Figures for dropside lorries were used rather than curtain side, as the latter is not included as a body type in the enhanced Stats19 collision data

The same analysis suggests that the lowest risk mainstream HGV type is the 7.5 tonne box/curtain side vehicle. This suggests that the main vehicle to be used as a baseline comparison when assessing why it might be that construction vehicles appear to be severely over-involved in collisions with cyclists, should be a 7.5 tonne box vehicle.

However, 7.5 tonne tipping vehicles also had a relatively low risk per vehicle km suggesting that the difference in vehicle size may be a more significant factor than the difference in body type. For this reason, it is also considered desirable to consider a vehicle typically used outside of the construction industry but of a comparable overall size to a typical tipper in excess of 26 tonnes. The closest vehicle in overall physical size to a 4 axle tipper is likely to be a 26 tonne box or curtain sided vehicle with 3 axles. It was therefore decided that the main analyses are based around a core group of three vehicle types made up of two construction vehicles and one 'control' vehicle most commonly used in other industries:

- axle rigid tipper, GVW 32 tonnes.
- mixer, GVW 32 tonnes
- axle rigid box/curtain sider, GVW 26 tonnes

3 Literature review

3.1 Background information

Section 2 analysed collision and exposure data to understand the relative risk of construction vehicle traffic compared with that for other types of traffic. It is also important to understand why this may be and what work is currently being undertaken that seeks to reduce collision rates. A literature review, including a review of grey literature and web documentation, was conducted. The findings are divided into two areas:

- Existing literature relating to HGV and construction collisions, including reasons for these risk levels
- Existing literature (mostly grey or web literature) relating to work being undertaken to reduce risk within the UK, along with an overview of relevant regulations.

3.2 Literature search findings

3.2.1 Literature search method

The TRL Library and Information Centre carried out a literature search to find published articles using combinations of the following keywords:

Construction vehicle	Off-site	Sensor
Construction logistics	Health and safety	Left turn
Site logistics	Cyclist	New technology
Development	Vulnerable road users	Vehicle design
Skip	London	Best practice
Tipper	Collision	Good practice
Mixer	Safety	Better practice
Freight	Conflict	Code of conduct
Heavy goods vehicle	Behaviour	Codes
Large goods vehicle	Attitude	Regulations
Light goods vehicle	Compliance	Supervision
Truck	Accident prevention	Enforcement
Lorry	Collision prevention	Inspections
Contracts	Position (on road)	Case study
Networks	Shared road space	Standards
Workers	Junction	Actions
Supply chain	Field of view	Ethics
Co-ordination	Mirror	

Some of the keywords were discarded after searching using each individually, referring back to the project scope and objectives. Preliminary searches were carried out to reduce the keywords to a more appropriate set. The main search divided the search terms into 3 main areas – subject area (freight/construction) – collision/accident prevention – methods of prevention/best practice and were put together in the following initial search string:

("construction vehicle" OR "construction logistics" OR "site logistics" OR skip OR tipper OR "heavy goods vehicle" OR HGV OR "large goods vehicle" OR LGV OR "light goods vehicle" OR truck OR lorry OR "supply chain") AND (cyclist OR "vulnerable road user" OR collision OR "accident prevention" OR "collision prevention" OR "position (on road)" OR "shared road space" OR junction OR "field of view" OR mirror OR "left turn")

This resulted in 1883 results, the vast majority of which were not relevant. These results were reduced down to a manageable number based on their relevance to the research, by removing keywords that brought up irrelevant results in the opinion of the Information Specialist carrying out the search. This resulted in a list of 78 abstracts identified for further review, supplemented by articles already known to the project team from previous work by TRL in this area. However, when considered in greater detail the majority of abstracts were rejected as being outside the scope of the current project, in some cases because they were not directly relevant, others because they were too narrowly focused on specific technical issues, others because they were too broad, providing little information specifically on cyclists and construction vehicles.

Searches were conducted using TRID, PubMed, Scencedirect and Google Scholar.

3.2.2 Existing reviews of cyclist and HGV collision research

The research into cyclists and heavy vehicles in general has already been extensively reviewed and summarised in previous TRL reports that have been used to inform the design of the current study, in particular Cookson and Knight (2010), Palmer, Walter and Keigan (2011) and Knight (2011). In the course of the review some other sources were found that provided helpful reviews of the key findings from research literature, in particular Fact Sheets from SWOV, the Netherlands Institute for Road Safety Research (SWOV, 2009a and 2009b, and Schoon, 2006). Some headline findings from these reviews are reported below.

3.2.3 The extent of existing research into construction vehicles

An important finding from the literature review was that, while there is a significant body of research into the problem of cycle collisions and large vehicles generally, no research was found that specifically considered construction vehicles or the construction industry.

Research has been carried out into the effects of different categories of heavy vehicles based on size and body type, but no research was found into reasons why construction vehicles might be over-represented in cycling casualties, as appears to be the case in London, or whether there are particular interventions that are of particular relevance to this industry (whether because of factors relating to the vehicles used or operational differences between construction and other heavy vehicle using industry sectors). It will not therefore be possible to draw significantly upon current research in developing recommendations for further action in these areas; the current project represents the

first serious attempt to investigate the issue, and the conclusions will follow from the work within it.

The reader is referred to the referenced reports above for more detailed information on the general findings in the literature that relate to collisions between cyclists and large vehicles in general. There are some headline findings however, summarised below, that may help inform the overall approaches that the industry should take, guided by more sector specific information from the other activities in the project.

3.2.4 *Headline findings*

Collisions involving HGVs and cyclists are recognised as a problem in many other countries, including those that have high levels of cycling, a high degree of provision of segregated cycling facilities and, overall, a lower rate of cycling casualties than the UK, such as The Netherlands and Denmark. O'Brien (2004) reports that in the Netherlands in 1996 29.4% of cyclist and moped user fatalities involved goods vehicles. A table comparing the proportion of 'small two wheeled collisions' in six European countries is presented in this report, and reproduced here as Figure 2.

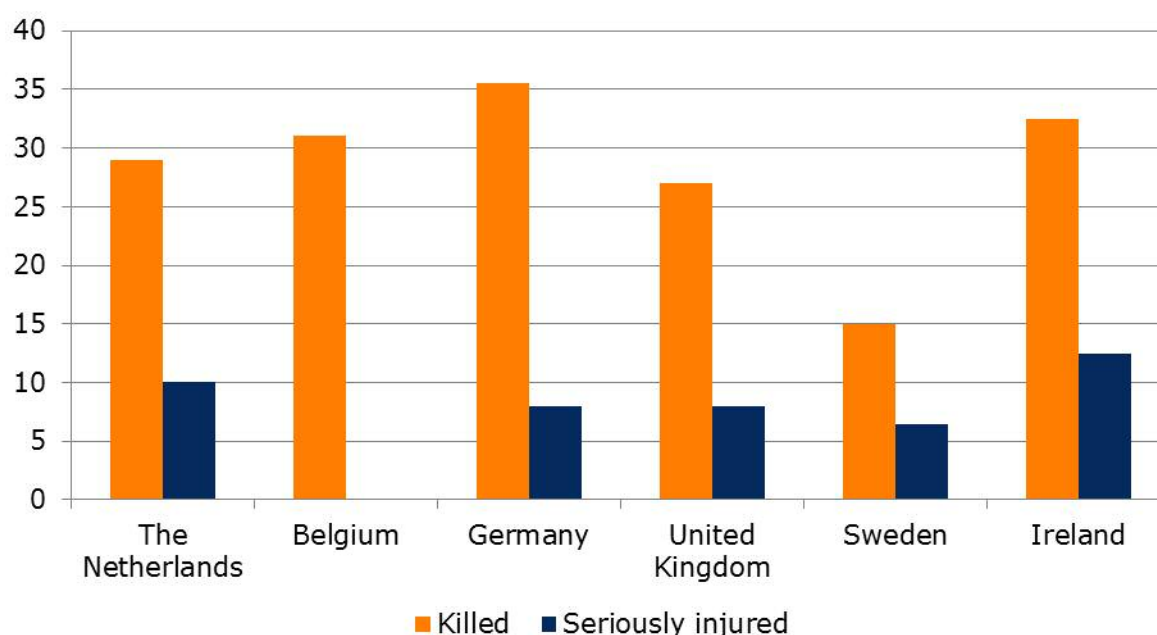

Figure 2. Goods vehicles involved in small two wheeled collisions (source: TNO, November 2001)

There are similar characteristics to the type of collisions that occur: a turning lorry does not give way to a cyclist moving straight ahead, most usually after the lorry has started to move after stopping at a junction. The lorry driver does not see the cyclist until it is too late, while the cyclist is often unaware that the lorry is turning (Schoon, 2006). O'Brien (2004) estimated that 56% of all fatal collisions involving an HGV and cyclist or motorcyclist in the Netherlands involved a vehicle making a right turn (left in the UK); however Knight (2011) suggests that this may be an overestimate, at least for the UK, providing a figure of 27% of cycle fatalities involving left turning HGVs in the UK. Unlike O'Brien's study, Knight's figure did not include motorcyclists.

Collisions involving heavier vehicles are disproportionately likely to be fatal, and the vehicles involved usually have higher windscreens – one piece of research found that

98% of vehicles involved in recent collisions when turning right (equivalent to left in UK) had windscreens higher than 1.5m (SWOV, 2009a).

3.2.5 *Blind spot mirrors*

There has been a lot of research into the benefits of blind spot mirrors, but evidence for their effectiveness, in particular following their compulsory introduction, is limited. While falls in collisions have been observed following the introduction of blind spot mirrors, other factors have been identified that could have accounted for this and there is strong evidence from some studies that improved driver awareness was at least as important. For example, evidence from the Netherlands showed a decline in collisions around the time when compulsory blind spot mirrors were introduced; however there was a rebound following this and casualty numbers reverted back towards their original levels (see chart below from SWOV 2009a). SWOV conclude that the reduction could have been caused by the increased publicity and awareness raising activity that accompanied the introduction of compulsory mirrors. This suggests that awareness raising and other behavioural change measures are at least as important as technological interventions such as mirrors, for this specific problem.

Interestingly a different pattern was observed in Denmark, where there was no clear trend before and after (Knight, 2011, citing Schoon, 2009).

In a review for the European Commission of the implementation of the Directive on retrofitting blind spot mirrors Knight (2011) concludes that:

"The number of vulnerable road users killed in collision with an HGV has fallen substantially such that in 2009 the number was less than was expected based on the predicted effects of Directive 2007/38/EC.

This would suggest that retro-fitting blind spots had been successful. However, the overall number of fatalities also fell more sharply in the same time period and the specific data available are limited. It is not, therefore, possible to quantify the extent to which the overall fall in HGV-VRU fatalities was a result of the fitment of the mirrors.

One of the limitations of this study is that the "after implementation" period was very short because EU data was only available up to 2009, the year in which it became obligatory for vehicles to be failed at annual inspection if they were not equipped with the new mirrors. Thus, future casualty data may provide additional insight, although other limitations may still prevent firm conclusions.

A wide range of additional technical measures have been identified that have the potential to further reduce the number of vulnerable road users killed in collision with heavy vehicles. These include measures relating to direct field of view, on-board indirect vision aids, roadside mirrors, sensors and warnings and rear steering. However, each will have advantages and disadvantages, the benefits will not be additive and no research has been found that objectively quantifies the relative costs and benefits to identify the most cost effective solution, or group of solutions." (P.52)

SWOV (2009a) identifies a number of reasons why blind spot collisions still occur despite the measures already carried out. These include:

- Blind spots still exist around the vehicle.

- Mirrors may not always be adjusted properly.
- There is a mental burden arising from the number of different directions in which a driver must look when turning, which includes the use of additional mirrors, and it takes a certain amount of time to switch direction of gaze as well, leading to times when cyclists can still be missed.
- Cyclists still have poor awareness of the location of blind spots and how to behave near large vehicles.

Additional measures are discussed by SWOV.

Improved education and awareness for both drivers and cyclists are recommended as short term measures. Fundamentally, as even slow collisions with moving heavy vehicles can lead to fatalities, segregation of cyclists and lorries is the ideal long term objective.

Segregation can be achieved physically through providing segregated routes for cyclists, restrictions on the movements of large vehicles in urban areas (e.g. restricted delivery times and routes or, more long term, banning heavy lorries and transferring goods to light vehicles for deliveries to city centres), or segregation by space or time through different junction layouts and signal systems.

3.2.6 Work-related road safety

Whilst not included in the literature review, since this solely sought to understand incidents between cyclists and construction vehicles, it is prudent to briefly mention existing literature on the impact of driving for work on collision rates. In short, there is a 'fleet driver' effect that goes beyond exposure; driving for work is more risky than other types of driving, and the risk factors at the general level are known. For example, Broughton et al. (2003) showed that compared with other drivers, fleet drivers more frequently report driving under time pressure, for long hours or when fatigued and also admit to engaging in secondary tasks such as making 'phone calls or reading maps while driving.

Broadly the risk factors for work-related driving have been shown to be fatigue, time pressure and distraction, which are also likely to be encountered by construction vehicle drivers during their daily activity; however it is not known whether they are more likely than other lorry drivers to be exposed to these risk factors.

Some companies have shown that it is possible to reduce their work-related road risk through management interventions, although there is not sufficient evidence to understand which individual components of different schemes are responsible for the improvement in safety (see Grayson & Helman, 2011 for a recent review and discussion). There is presumably some potential for management to impact (both positively and negatively) on collision involvement with cyclists, but again, there is limited existing literature which identifies how management may differ between construction fleets and other fleets.

3.3 Review of current guidance and activities

3.3.1 Guidance provided by organisations/associations

A number of organisations publicise their health and safety documentation via their website. Two large organisations were reviewed in terms of the information and

guidance relating to cyclists (Balfour Beatty and the Mineral Products Association). These are described below.

3.3.1.1 Balfour Beatty

Balfour Beatty (BB) has a 'Zero harm' campaign with its own website (<http://www.zeroharm.bbrce.co.uk/>). This campaign, launched in 2008 and running until the end of 2012, 'aims for zero deaths, injuries to the public and ruined lives by 2012'.

The campaign aims to deliver on seven shared commitments across all Balfour Beatty businesses, including subcontractors. These are:

Eliminating fatal risks

All our businesses will identify fatal risks and establish Zero Harm design, management and behavioural protocols to eliminate them.

Eliminating hazards

All our businesses will identify and plan out hazards in all activities they undertake.

Maintaining Zero Harm day to day

All our businesses will establish and maintain management, monitoring, review, audit and assurance systems geared for Zero Harm.

Keeping the public safe from harm

All our businesses will manage and maintain Zero Harm levels of separation, security, monitoring and stewardship to safeguard members of the public from exposure to our hazards.

Keeping all our people healthy

All our businesses will conduct health checks and health risk assessments to ensure there is no long term harm to health from working in our business.

Working with our customers

All our businesses will enlist the support and co-operation of customers to achieve Zero Harm.

Making Safety personal

All our businesses and the people within them will make Safety personal.

BB Regional Civil Engineering has held around 400 workshops which critically evaluate key elements of their work, focusing first on fatal risks, one of which is traffic management. The workshops are each attended by five volunteers who discuss the topic and recommend improvements.

There are six working groups, one of which is 'Drive Safe, Arrive Safe'. This group focuses on driver safety, particularly driver behaviour and awareness, vehicle safety, and safe journeys. The group has created an e-learning course, driver risk index and Zero Harm survey to improve driver awareness. There is also a driver incentive scheme to encourage drivers to commit to the 'Drive Safe, Arrive Safe' message, as well as a 'Driver Miser' scheme which monitors fuel usage, and the development of vehicle telematics to monitor driver behaviour. BB Plant and Fleet Services employees also undergo driver licence checking. However no mention is made of cyclist safety; this does

not mean it is not considered or that drivers are not trained in this area, but by making it a distinct topic area and including it in mission statements, organisations can demonstrate their commitment to cyclist safety.

3.3.1.2 Mineral Products Association

MPA have a Cycle Safe campaign and six-point plan which aim to prevent collisions between cyclists and LGVs by raising awareness on both sides on cycling and driving safely. A member of the Technical Advisory Group shared the MPA's actions to date relating to the six points of the Cycle Safe plan, which are described below:

1. Promote Driver and Industry Awareness

MPA publicised the Cycle Safe campaign to its members, so that they can take part and know about the safety materials available to them. MPA provided its members with briefing materials and resources relating to cyclist safety.

A Member Cycle Safe Exchange was organised by MPA in March 2012 to examine what MPA and its members can do to reduce the risk of collision between industry delivery vehicles and vulnerable road users, such as cyclists. The event was a facilitated exchange of around 30 representatives of MPA members which discussed the operation of current safety initiatives, experiences of different vehicle equipment options and the perception of this issue throughout the country.

2. Promote Cyclist and Public Awareness

MPA organised a 'Cycle Safe' event in Oxford in March 2011. This was the pilot event for MPA's national Cycle Safe scheme. Over 100 cyclists participated and were given the opportunity to sit in the driver's cab of an aggregates lorry, in order to understand cyclist visibility to the driver, and learn about safety issues.

MPA launched its national Cycle Safe campaign and Six Point Plan at the Metropolitan Police's 'Exchanging Places' event in London in June 2011. The event attracted many cyclists who were able to sit in one of four vehicles to experience visibility from inside the driver's cab.

3. Improve Driver Training

The existing CPC-approved Driverskills course which all delivery drivers for MPA members are required to take was extended to cover all vehicle types in the sector and to include cyclist awareness training. This training has been undertaken by 27,000 drivers to date. MPA is working with training providers to develop a specific CPC approved module on cyclist safety and vulnerable road users.

4. Encourage Members to use Appropriate Technological Adaptations to Minimise Risks to Cyclists and Exchange Experience

MPA has circulated guidance for members on available vehicle safety equipment designed to minimise the risk of collisions with cyclists and vulnerable road users. The MPA Member Cycle Safe Exchange generated feedback on the performance of such safety equipment. MPA will monitor information and feedback relating to safety equipment in order to better inform members.

5. Liaise with Schools

MPA has issued guidance to members on how to run road safety events in schools.

6. Work in Partnership

MPA contributes to or is a member of a number of groups and forums relevant to improving cyclist safety.

3.3.2 Construction Design and Management Regulations

The CDM regulations (2007) place a legal duty on those involved in construction work, but do not extend to construction vehicles driving to or from construction sites. The regulations stipulate that on traffic routes (on construction sites) there are “effective arrangements for warning any person liable to be crushed or trapped by any vehicle of its approach”.

The regulations also state that “suitable and sufficient steps shall be taken to ensure that, where any person may be endangered by the movement of any vehicle, the person having effective control of the vehicle shall give warning to any person who is liable to be at risk from the movement of the vehicle”. This is an example of the arbitrary distinction between ‘on site’ and ‘off site’ when it comes to driver safety.

3.3.3 FTA Cycling Code (2011)

The FTA Cycling Code (FTA, 2011) was developed in co-operation with the London Cycling Campaign, the Metropolitan Police, the Institute of Advanced Motorists and TfL. It sets out expectations of all road users and provides standards for on-road behaviour which aim to reduce collisions between commercial vehicles and cyclists. The code provides toolkits for cyclists, drivers/operators, and employers.

Future development of the code will incorporate the following (pages 4 and 5):

Develop reporting and investigation processes for KSI and slight injuries

In order to monitor progress FTA needs to gather company-level data about collisions and near misses. If such data is not available then FTA should be encouraging members to record it. Data can also be shared with the Freight Operator Recognition Scheme (FORS) Silver scheme that gathers this data. Processes should cascade to include sub-contractors.

Journey planning (route planning tools)

FTA will work with a mapping company to develop routing tools to avoid the Cycle Superhighway network. This will also link to the TfL Journey Planner.

Governance group for developing the code

A governance group has been established to oversee the future development of the code and further actions needed to deliver the code’s objectives.

Develop training offer (supporting FORS DCPC and developing FTA DCPC module)

The FORS Driver CPC module focuses on driving safely in London. As long as FORS training is available, FTA should continue to direct operators towards it.

Support Met Police in developing enforcement and awareness activities (‘Exchanging Places’)

This is a key opportunity for promoting safety messages that FTA can support by encouraging members to provide vehicles for events.

Develop agreed position on vehicle engineering/street furniture (and funding pot)

With the tightening of TfL and Greater London Authority (GLA) budgets there are opportunities to sponsor the installation of Trixi mirrors¹¹ and other street furniture.

Memorandum of Understanding

The final page of the document is an MOU on cycling between FTA and TfL, in which the two organisations agree to work co-operatively to promote the uptake of cycling as a safe and sustainable mode of travel and to promote sustainable and efficient logistics.

- FTA and TfL agree to work co-operatively. They will deploy their respective resources and influence to address the following challenges.
- To identify locations and times of day where loading and unloading activity or commercial vehicle routing might conflict with the objectives of a clear, safe and effective cycle route and establish mutually suitable, feasible and acceptable solutions for addressing these.
- To identify key safety messages for all road users, particularly cyclists and large vehicle drivers, and deploy the most effective means and channels to convey them.
- To identify training needs for all road users, particularly cyclists and large vehicle drivers and the best opportunities for funding and delivering them.
- To identify more equitable approaches to road traffic enforcement and traffic engineering measures which strike the balance between enforceability and practicality.
- To share details of forthcoming events and announcements with a view to adding value by broader engagement.
- To promote the uptake and effective use of properly appraised vehicle engineering interventions.
- To identify, develop and report on suitable metrics to measure the effectiveness of the agreement.

3.3.4 Driver CPC (Certificate of Professional Competence) syllabus

The EU passed EU Directive 2003/59/EC which is a European Directive for all bus, coach and HGV drivers. The aim of the driver CPC is threefold:

- To improve drivers' knowledge and skills before they start driving
- To continue to develop drivers' knowledge and skills throughout their working life
- To improve road safety through better qualified drivers

Professional drivers who gained their licence before September 2008 are now required to undertake 35 hours of driver training every five years in order to maintain their licence. For new drivers there is increased initial training and testing including the theory test

¹¹ Trixi mirrors are installed at junctions to give drivers a better view of cyclists on the left hand side of their vehicle.

(including multiple choice questions and hazard perception), case studies, practical test and CPC practical test (vehicle safety demonstration), followed by the periodic training.

Periodic training is designed to improve the knowledge of the driver and could include courses on subjects such as disability awareness, tachograph regulations and safe and fuel-efficient driving. Training centres delivering this training must be approved by JAUPPT (Joint Approvals Unit for Periodic Training), and each module must be a programme of at least seven hours. There are no tests or exams involved but training centres will be required to evaluate each course to ensure that those attending have benefited from the training that they have received.

The driver CPC is therefore not solely related to driver safety, but covers a number of other aspects of commercial driving. There are only two relevant objectives in the CPC syllabus relating to safety (JAUPPT, 2010, p.18, 19):

- ability to load the vehicle with due regard for safety rules and proper vehicle use: forces affecting vehicles in motion; use of gearbox-ratios according to vehicle load and road profile; calculation of payload of vehicle or assembly; load distribution; consequences of overloading the axle; vehicle stability and centre of gravity.
- to make drivers aware of the risks of the road and of accidents at work: types of accidents at work in the transport sector; road accident statistics; involvement of lorries/coaches; human, material and financial consequences.

There is no stipulation as to which subjects are required to be covered within the 35 hours, and therefore a driver may receive no additional training with regards to driver safety within their periodic training. A total of 3,122 CPC (both HGV and PCV) courses had been approved by the end of September 2012 (DfT, 2012). A keyword search for courses on the JAUPPT website (www.jauppt.org.uk) was conducted with the search term "cyclist" identified eight approved programmes for LGV drivers, a further one for "cycling" and a further three for "vulnerable [road user]", totalling 12 approved CPC courses which consider these as key topic areas (although these are often merged into wider topics such as "cyclist awareness, vehicle defect detection and reporting" and "Driver/Cyclist Awareness and Emergency First Aid"). This is likely to be an underrepresentation of the number of courses which include some element of cyclist safety and/or vulnerable road users as it is dependent on the provider using these terms in the description of the course. Unfortunately, it was not possible to obtain directly from JAUPPT the exact number of approved courses which included training on cyclists and/or vulnerable road users.

3.3.5 Croydon Council Code of Practice

The Code of Practice provides advice to assist developers and their contractors to undertake their works using best practice and thereby reduce their impact on local communities. Croydon Council's Code of Practice includes the development of a Construction Logistics Plan, which aims to ensure that the negative effects of vehicle movements are minimised. The Code states that some sites will be expected to submit a CLP for formal planning approval, while those without a formal CLP should adhere to the principles of the Code. See section 4 for more on CLPs and cyclists.

3.4 Overall findings from literature review and implications for research design

The primary finding from the review of the literature is that there is limited previous research which specifically looks at collisions between cyclists and construction vehicles. With respect to vehicle and mirror design, some evidence can be drawn from literature that has investigated HGVs used for general haulage. Wider work-related road safety research has consistently shown that when driving for work, drivers are more likely to undertake risky secondary activities, and be driving while under time pressure or fatigued, and also have a higher collision rate than non-work drivers. However, none of this previous work explains the difference between construction vehicles and general haulage vehicles in the risk of a collision involving a cyclist. The current research seeks to address this lack of evidence.

Based on the reviewed literature, and the work being conducted by the organisations discussed in sections 3.3 to 3.3.5 potential areas of risk fall into the following categories:

- Vehicle specifications
- Mirror specifications
- Driver behaviour
- Pressure on drivers (via management or contractual obligations)
- Health and safety management

For each of these, the general research question is “What is special about the construction industry that might explain their apparent over-involvement in fatal and serious injury collisions with cyclists?”

The following sections of the report seek to understand more about these issues.

4 Safety issues relating to vehicle routing and delivery restrictions

At the macro level within London, routing and delivery must conform with the London Lorry Control Scheme and restrictions of Red Routes. At the local (in this case Borough) level, it becomes a matter for the Local Authority to agree and subsequently authorise local routes within their boundaries, in particular the immediate access and egress areas of individual construction sites.

The current guidance – the TfL document ‘Building a better future for freight CLPs’ - highlights the benefits to safety of Construction Logistics Plans (CLPs), and that cyclists are at risk from construction vehicles, but does not give specific actions to take. Planners would need to consult appropriate guidance which at present does not cover specific measures to accommodate cyclist safety.

Croydon is the strongest Local Authority in the development and implementation of CLPs in London. TfL also have very strong contractual conditions which include cyclist and vulnerable road user safety.

4.1 Purpose of Construction Logistics Plans and their role within the Transport for London ‘London Freight Plan’

Construction Logistics Plans (CLPs) constitute one of the four main project areas within the Transport for London (TfL) London Freight Plan, published in 2007. CLPs do not sit in isolation; rather they interact with each of the other main projects, in particular Delivery and Servicing Plans (DSPs) with which there is a dovetail of many key component parts.

CLPs have at their core a strong emphasis on interventions and measures to generate environmental improvements as a direct result of logistics efficiency during construction. The main emphasis and objectives are to minimise disruption to the wider and local community through better and smarter use of the supply chain, thus reducing the number of delivery, collection and servicing journeys made to construction sites. However, as CLPs are also included within the Freight Plan’s theme of improvement to road safety, in particular protection of vulnerable road users, there is some emphasis on improving the safety of journeys connected with construction sites.

There is anecdotal comment that construction vehicles may pose a threat of collision to cyclists in part because of the transient nature of construction sites; the consequential requirement for drivers to make journeys on unfamiliar routes; and the sub-contracting pattern of construction haulage. CLPs provide the opportunity to address each of these issues and are examined in this section of the report.

Cyclist safety is addressed in the current Crossrail project through a number of concurrent initiatives that include the requirement for contractors to register as FORS members and join the Scheme, safety equipment fittings to vehicles, appropriate driver training and the Crossrail Driver Information pack.

4.1.1 Progress made to date in CLP design – generic output

The TfL CLP Guide “Building a better future for freight: Construction Logistics Plans” was developed and published in 2009. The Guide gives clear direction to users on the

benefits from an environmental and safety perspective of producing and adhering to a CLP.

It is important to acknowledge that CLPs are in place to generate thought, planning and action by construction companies on behalf of themselves, their supply chain and sub-contractors, in order to address potential local conflict due to the inherently disruptive nature of construction.

The CLP addresses a number of environmental concerns; in particular the volume and nature of construction-related freight movements and the requirement to capitalise on the opportunity to minimise these wherever possible (in particular to eliminate wasted and unnecessary journeys).

Whilst the TfL CLP guide is in the public domain the actual requirement for CLP use is very localised and very much dependant on the individual London borough planning authority. This may be a compulsory requirement for all major construction projects (for example construction projects commissioned by TfL and London Borough of Croydon Council).

The detail contained within individual CLPs is varied. Often, perhaps due to the legislative and cultural embedding of Health and Safety within the construction industry, CLPs are written as a dual purpose document serving as both a logistics and construction Health and Safety plan.

4.1.2 Croydon Council development of CLPs

The development of CLPs has been built upon by the London Borough of Croydon in partnership with TfL. The work is managed by a Steering Group which has implemented the production of CLPs as a prerequisite to planning consent within the Borough. Croydon is, at the time of this report, experiencing a series of regeneration projects – particularly in the Town Centre – and is an Area Opportunity Planning Framework (OAPF). As a Borough it has implemented CLPs as a compulsory element of the planning requirement from May 2012. There are plans for this information to be shared with other Boroughs, initially through the South London Air Quality Cluster Group.

In order to assist both Council enforcement and the construction organisations' production of CLPs, a suite of four documents and a case study have been developed which provides a reference bank for each aspect of CLP production.

The Croydon Guidance documents are described below:

4.1.2.1 Construction Logistics Handbook

This particular document provides the framework CLP for Croydon. It provides the user with the policy background and focuses on the benefits of a holistic approach to CLPs where major redevelopment is taking place. Most importantly, from a cyclist safety perspective, this particular document provides the template for a CLP and includes important road safety related requirements.

4.1.2.2 CLP Writing Instruction

This has recently been drafted (June 2012) and provides the inexperienced CLP writer with a step by step guide to writing a CLP, following the Construction Logistics Handbook template.

4.1.2.3 Code of Practice

This provides the reader with a wide range of information, in seven sections, which address a number of environmental issues and sets out expectations in respect to compliance. One of the sections - Site Operation and Access - specifically incorporates road safety.

4.1.2.4 Framework CLP Planning Requirements

This document is a quick guide to the essentials of a CLP and also includes Site Operations and Access.

4.1.2.5 Croydon Civic Redevelopment Case Study

One of the focal redevelopment activities within Croydon Town Centre is the current building of the new Public Service Delivery Hub for the London Borough of Croydon Council. This has been an exemplar case for Croydon and a case study has been produced to give future CLP writers an example of the standard that can be required. In this particular case the CLP was produced by Alandale Logistics for Sir Robert McAlpine Ltd.

4.2 London Borough of Croydon CLP template

The template has been created and is being implemented in the London Borough of Croydon. It was introduced in May 2012 for all new Town Centre and selected Borough-wide construction projects, and is part of the planning requirement.

This section breaks down the CLP template into the constituent parts and explains where they are applicable to road safety and incorporated in the collective guidance. It is important to remember that the positive effects on cyclist safety will be both direct and implied within wider road safety.

4.2.1 Supply chain management

Within Supply Chain Management there are a number of elements that have direct relevance to vulnerable road users, in so far as they provide a framework for the rationalisation of construction related traffic and procedures that support safer road movements through:

- The reduction in the volume of road movements
- Planned frequency of delivery, collection and servicing
- Routing to and from the construction site
- Immediate access to the construction site

4.2.1.1 Delivery booking and scheduling

A key element of any CLP is the requirement to organise and to put in place discipline for construction site deliveries, collections and servicing. Most construction organisations have their own booking systems that may vary in their degrees of automation and complexity. However, TfL's new Site Scheduler system has been developed and is currently being trialled within Croydon by Berkely Homes at their Saffron Square development project. This system, once piloted, will be available for use across London.

From a cyclist safety perspective, booking and scheduling provides a construction site arrival window that is designed to eliminate construction traffic congestion and other hazards at the site entrance and on immediate approaches.

4.2.1.2 Off-site fabrication

Off-site fabrication is the process of manufacturing portable constituent parts of a building project and provides construction companies with the opportunity to reduce the frequency of deliveries to site and thus remove LGV traffic. These are often encouraged from an environmental perspective, but their transportation must involve careful management, especially if prefabricated loads are classified as abnormal loads.

4.2.1.3 Contractor's handbook

Construction site activity is characterised by multiple phases and the extensive use of sub-contractors. Therefore the importance of an effective handbook for sub-contractors is emphasised in the guidance documents. Very often this will be the only interface between the majority of construction site personnel and any CLP that is produced. This document is an ideal medium to include awareness and safety for cyclists and other vulnerable road users.

4.2.1.4 FORS

The benefits of FORS accreditation are stressed throughout the Croydon guidance. As road safety – in particular danger to cyclists and other vulnerable road users – is a major theme of FORS accreditation, this will act as a conduit for better driver risk management.

4.2.1.5 Site access

The requirement to utilise the appropriate road network is explained for all heavy vehicles as is the requirement to clear all routes through Council planning channels. The guidance also highlights the use of TfL Red Routes and reiterates compliance with the Low Emission Zone. Whilst the use of Red Routes does not necessarily lead to improved cyclist safety they are intended to be free flowing and to present less traffic-generated obstacles and hazards than other London routes.

4.2.1.6 Local access routes

Local Access Routes are a critical component of cyclist safety within CLPs. As construction sites can be located anywhere on the road network, it is imperative that all delivery and service vehicles are appropriately routed to and from the construction site to minimise interaction with vulnerable road users.

4.2.1.7 Site operation times and access times

The access and operating times of any construction site are a balance between minimising the local disturbance (in particular noise, dust and vibration associated with demolition and construction) and the opportunity to manage deliveries to construction sites outside of peak traffic periods.

4.2.1.8 Site access arrangements

Potentially dangerous pinch points for any construction site are the access and exit points to and from the adjacent road network. These should be planned and located in such a way as to:

- Not interfere with traffic flow on the adjacent road(s)
- Not present any hazard to pedestrians and cyclists
- Incorporate the site vehicle booking system described above
- Protect the site from unauthorised vehicle and non-vehicle access, including cycles.

4.2.1.9 On-site arrangements

This section of the CLP focuses on vehicle safety within the construction site and has direct relevance to cyclists who travel to and from site.

4.2.1.10 Cranes and equipment

The movement of cranes and equipment can be particularly hazardous to cyclists due to their size and the position of the driver on the vehicle. This section requires the movement to and from site to be planned in detail, including routes and timings.

4.2.1.11 Swept path analysis

Swept path analysis provides construction sites with a template of routes that include the full signature of vehicles moving to, from and within a construction site. This ensures that all vehicle overhangs and movement arcs are accounted for in path design. This has to include the vehicle access and exit points and needs to be updated when there are changes to site layout. This activity takes in to account vulnerable road users at the points of access and egress.

4.3 Examples of CLPs in use in Croydon

CLPs have been used in Croydon for major construction activities, including demolition, for several years. They are now (since May 2012) a compulsory element of the Croydon Council planning process. A number of examples have been reviewed and salient findings are summarised below. Particular attention has been given to best practice in relation to work-related road risk.

4.3.1 General findings

The quality of CLPs submitted to Croydon Council has been varied. As stated earlier in section 7.2.4, the legislative and cultural link between the construction industry and Health and Safety has had the effect that general Health and Safety features in CLPs to one degree or another. This can be to the detriment of the CLP as the construction company can start taking responsibility for activities on site with insufficient attention to road users outside of the immediate points of access and egress.

It is not surprising that the examples of CLP best practice – in particular as they apply to road safety – are where the CLP has been produced on behalf of the construction

organisation by a specialist construction logistics provider (either as a construction partner or on a consultative basis).

It is important to emphasise that whilst there are examples of best practice CLPs from a road traffic management perspective, they do not specifically mention cyclist vulnerability.

4.3.2 Content of exemplar road safety orientated CLPs

The best examples of CLPs written for construction projects in the London Borough of Croydon from a road safety perspective include:

- Summary of construction activity by phases to contextualise activity
- Listed sub-contractors
- Full details of FORS accreditation and the requirement to register for accreditation
- Detailed site plans including:
 - Access
 - Egress
 - Swept path analysis of the above to show clearance distances for other road users
 - Photographs
 - External signage arrangements
- Access routes to construction site, including:
 - Site location in London context
 - Site location in local context ("A-Z" map page)
 - Description of routes to construction site from all approaches
- Details of local road user risks:
 - Schools
 - Bus stops
- Compulsory driver briefings on entrance to the site
- Reversing policy and instructions
- Loading policy and instructions – all internal to construction site
- Wheel washing facility

4.4 Sample of best practice examples of CLP use outside of Croydon

4.4.1 General findings

Completed CLPs are not usually found within the public domain. That said, there are some examples of best practice to be found that pay attention to construction site routing and to the immediate road environment. The example selected for this report is the Earls Court and West Kensington Opportunity Area Framework Logistics Plan by EC Properties Ltd. This has been selected because:

- It is in the public domain:
(http://www.rbkc.gov.uk/idoxWAM/doc/Revision_Content-840042.pdf?extension=.pdf&id=840042&location=VOLUME2&contentType=application/pdf&pageCount)
- It is written as a higher level (Opportunity Area Framework) CLP for a multi-phased and sequenced redevelopment scheme over a 19 year period including:
 - Deconstruction
 - Demolition
 - Construction
- The site has multiple ownership including TfL
- It provides complementary best practice to the Croydon examples
- It is recently published (December 2011)

4.4.2 Content of exemplar road safety orientated CLPs – external to Croydon

- Summary of construction activity by phases to contextualise activity
- Full description of:
 - Access
 - Egress
- Access routes to construction site, including a description of routes to construction site from all approaches
- Volume of vehicle movements by phase
- Wheel washing arrangements
- Delivery Schedule plan including:
 - Booking system
 - Remote holding area
- Traffic routing using existing roads, minimising use of minor roads
- Traffic routing including consequential road closures and diversions
- Pedestrian safety

4.5 Conclusions

This review of CLPs found that, while they are a key area of the London Freight Plan, there is no pattern to their use within London, and where they are used they are not always monitored. Safety tends to be focused on the site itself and the immediate area, and appears to come second to environmental issues.

In some instances CLPs are a planning requirement from the relevant Local Authority, for example the London Borough of Croydon. In other instances they are a contractual requirement, for example work commissioned by Transport for London. CLPs are also produced, as a matter of best practice, particularly where the construction site itself is a high profile project.

Primarily CLPs are produced in order to reduce the impact of construction on both the wider and local environment by challenging construction organisations to reduce and co-ordinate traffic to and from construction sites through a variety of actions that will ensure construction traffic is minimised. Safety of traffic movement is a key theme of CLPs, but can be very much focused on the immediate local area.

Work to further develop CLPs and to introduce them as a compulsory element of the planning process is in progress. This work is being led in partnership between TfL and the London Borough of Croydon. Four documents have been developed which include road safety and traffic management sections that address the requirement for construction related vehicle journeys to be planned, co-ordinated and journeys to be made on roads most suited to their characteristics. The documents are strong advocates of FORS accreditation for vehicle operators.

The overall quality of CLPs and their attention to road safety, including vulnerable road users, is varied. Due to the Health and Safety culture embedded within the construction industry, CLPs can lose focus and become dual purpose documents.

There is, on examination, a correlation between quality of CLPs and their development by construction logistics professionals, either internal, contracted or consultant. In these instances due attention is given to routing, scheduling, traffic management and site access. Examples of Best Practice have professional logistics input. Specific examples of cyclist safety are not present in CLPs, but they have the capacity to act as strong signposts to cyclist safety as part of any work-related road safety package: this needs to be improved.

5 Direct and indirect visibility assessment

As part of the research project a study was performed to investigate the areas to the nearside and front of construction and logistics lorries that would be available, and those that would not be available, to be seen by a driver when looking in the appropriate direction. The assessment involved the evaluation of direct and indirect visibility. The term direct visibility describes the direct view through a window or side window of a vehicle and is what the driver can see without any further visual aids. The indirect visibility is the visible area that is seen by a driver with the use of a mirror, camera system or other component. It must be stated that although the study shows all the visible areas around the nearside and front of the vehicle an object, pedestrian, cyclist or other vehicle would only be visible should the driver look in that particular mirror or through that particular window.

Three vehicles were assessed as part of the project, these were determined from analysis described in section 2. For clarification the three vehicles were:

- DAF CF75.360 Mixer (index: KE56 KAK)
- DAF CF85.360 Tipper (index: GN58 KSJ)
- MAN TGM 26.290 Curtain side (index: DE61 EKK)

5.1 Mirror classifications

The vehicles assessed as part of this project were all fitted with Class II, IV, V and VI mirrors as shown in Figure 3.

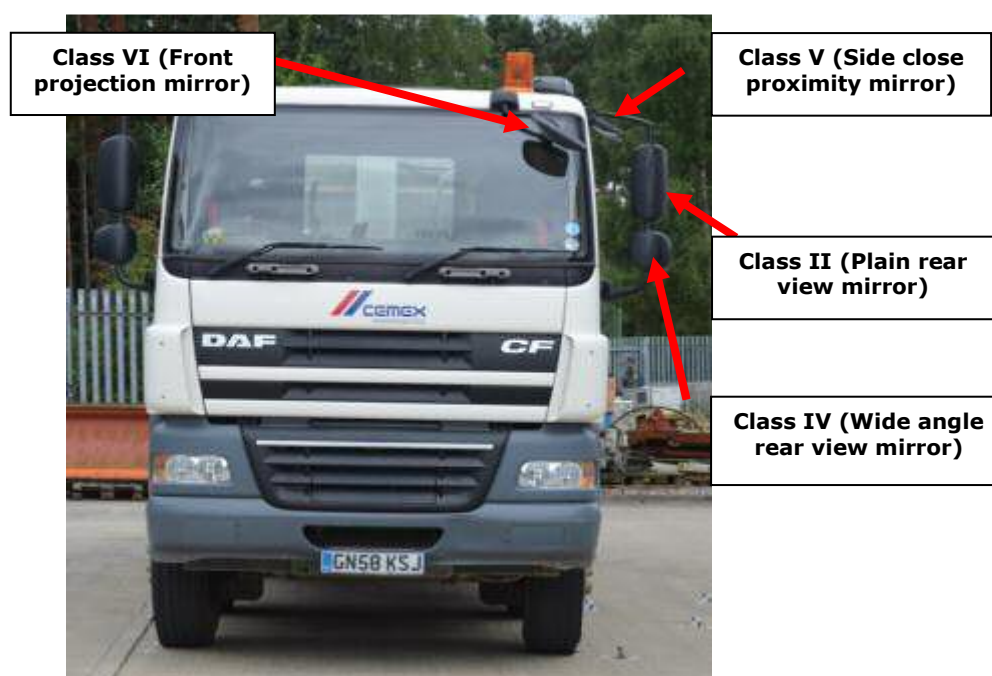

Figure 3: Classification and description of the mirrors discussed and assessed in this project. The image is of the DAF Tipper lorry

A Class II mirror is the large plain rear view mirror that is usually fitted within a cowling on the exterior of the vehicle, usually on a frame attached to the door. The mirror 'glass' is flat and does not distort the image. The Class IV mirror is a wide angle rear view mirror; it is generally smaller in size and can be positioned above or below the Class II mirror in either its own cowling or combined in the same cowling as that of the Class II mirror. To achieve the wide angle and thus wider field of view than the Class II mirror the Class IV mirror is convex in shape. Although the convex shape increases the field of view, it has the potential of distorting the object within the mirror, for example a straight line (such as a road marking, or a sign post) can appear to be curved within the mirror image. The effect is more pronounced towards the edges of the mirror and is dependent upon the severity of the curvature of the mirror.

The Class V mirror is known as a side close proximity mirror and has also been termed as a 'kerb' mirror. This mirror provides the driver with the ability to see the area directly next to the nearside front of the vehicle in the vicinity of the nearside front wheel. Some of these mirrors will extend the field of view forward of the drivers cab. The mirror itself is convex in shape and thus is similar to the Class IV mirror in that an object within the mirror image can be appear distorted. The Class V mirror is usually mounted above the nearside side window on the top of the door frame. It was apparent that the MAN curtain side lorry had also been fitted with a Class V mirror on the offside of the vehicle, directly above the driver's side window. It is believed that this is an optional extra for this make of vehicle and it is not required currently as part of a regulation. An example of the effect that the convex mirror has on straight lines is shown in Figure 4, where the straight line of the nearside side window frame is shown in the Class V mirror to be curved.



Figure 4: The Class V convex side close proximity mirror fitted to the MAN Curtain side lorry showing the distortion in the image to the straight line of the nearside side window frame where it appears curved in the image

The Class VI mirror is known as the front projection mirror and provides the driver of the vehicle with an opportunity to see objects, pedestrians, cyclists and other road users or objects directly in front of the cab of the lorry. The mirror lens is convex in shape to increase the field of view and provide the driver with as wide an area of coverage as possible. However, as mentioned above, the convex mirror can cause objects to appear distorted and thus can result in them being more difficult to identify. In most cases the Class VI mirror is mounted on the exterior of the vehicle to an arm that protrudes from

the upper nearside corner of the windscreen (as shown in Figure 3). However, the DAF Mixer lorry assessed as part of this project had been fitted with an internally mounted front projection mirror which was fitted to the top of the A-pillar on the nearside of the vehicle near to the windscreen (Figure 5). Some vehicle manufacturers position the Class VI mirror centrally above the windscreen.



MAN Curtain side



DAF Mixer



DAF Tipper

Figure 5: The images show the internal view towards the nearside of the lorries, showing the four mirrors fitted on the nearside. The DAF mixer image shows the internally mounted front projection mirror

5.2 Visibility assessment process

The DAF Mixer and DAF Tipper vehicles were both provided to TRL by Cemex and the MAN 26t Curtain side was supplied by Dooley Rumble. The assessments were performed at TRL's facility in Wokingham, Berkshire on 13 August 2012 (Cemex vehicles) and 17 August 2012 (Dooley Rumble vehicle).

The assessment of each vehicle was performed using the same driver (holder of an LGV licence) to set the seating position and mirrors. By using the same driver it reduced any variables within the results that would occur if different drivers were used. It is likely that even two people of the same size, mass, etc, would adjust the mirrors and seat differently, due to the fact that each person has their own preferred settings.

The driver was asked to sit within the vehicle and change the seating position and mirrors to suit them and ensure that they were adjusted as they would be, should the vehicle be being driven. Once the driver was satisfied with the seating position and mirrors, the eye position of the driver was measured with respect to fixed points within the vehicle and then photographed. Based on the measurements recorded, a steering wheel mounted laser assessment tool was fitted (Figure 6). It was found that due to the

different heights of the vehicles, the driver's eye position relative to the ground varied between the DAF Tipper and that of the DAF Mixer and MAN Curtain side. The eye position of the driver in the DAF Tipper was approximately 2.58 metres above ground, whereas the eye position of the driver in the DAF Mixer and MAN curtain side was measured as approximately 2.49 metres above ground.



Figure 6: Comparison of the driver seating and eye position and the position of the steering wheel mounted laser assessment tool (DAF Tipper)

The laser assessment tool comprised a steering wheel mounted frame, an adjustable arm and a rotating mount for a laser pen. The rotating mount for the laser pen simulates the eye of the driver and enables the laser pen to simulate the line of sight from the eye (Figure 7). The laser projects a point on the ground where a marker is then placed. The laser is traced around the extents of the windscreen, nearside window, rear cab window (for DAF Mixer and Tipper), front projection mirror and the nearside mirrors. The first point at which the laser point strikes the ground is the first point at which the ground becomes visible to the driver and similarly in the mirrors as the laser point is reflected off the mirror it strikes the ground at the point where the driver first sees the ground in the mirror. By placing markers on the ground it is possible to map the area at ground level that is visible to the driver through either the windows or the mirrors; this consequently identifies the borders of the ground visibility zones.

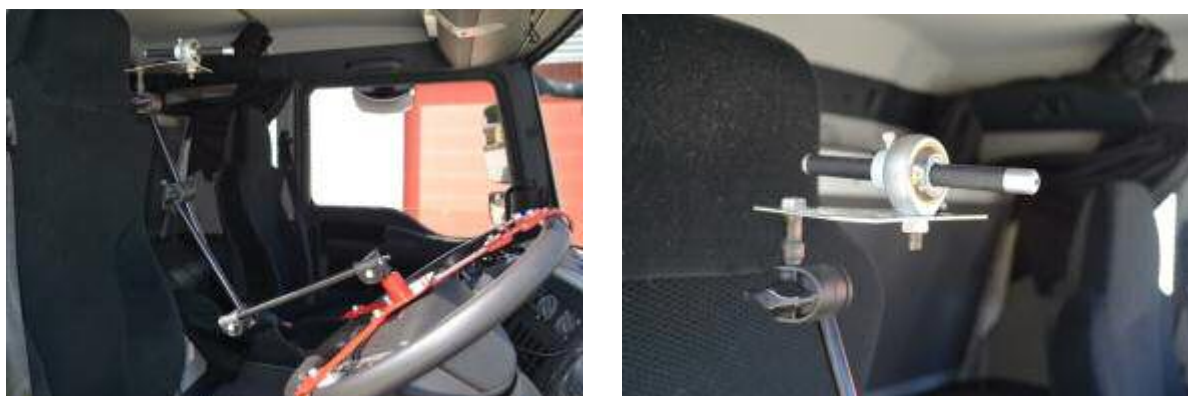

Figure 7: The steering wheel mounted laser assessment tool and the rotating mount to simulate the eye

This process does not consider the driver's peripheral vision, it however, does consider the visibility available should the driver be looking in that particular direction. For example if a driver was looking directly ahead through the windscreen and a person or object was available to be seen in the nearside rear view mirrors then although they are available to be seen the driver may not see them without the driver rotating his/her head in that direction to look in the mirror.

Movement of the head in the vertical, lateral or fore/aft position will affect the visible area available. It is unknown how much movement, if any, other than simple rotation at the eye and neck drivers make as they check the windows and mirrors. Consequently, no head or body movement (other than head and eye rotation) has been considered.

Once all the areas had been assessed with the laser tool, the markers and the vehicles were all scanned using a Riegl LMS-Z360i laser scanner to capture accurate data of the lorries and the positions of the markers. An overview of the three lorries (as point clouds) is shown in Figure 8. The point cloud is the cleaned and aligned data which is obtained from the laser scanner and is a mass of data points. By the term cleaned it is meant that the unwanted environment data is removed and discarded. The images do not show the visibility markers.



Figure 8: Point cloud images of the DAF Mixer, DAF Tipper and MAN Curtain side lorries

From the laser scan data it was possible to create a three-dimensional representation of the lorries with the visibility zones attached. Areas that were not visible (commonly known as 'blind spots'), based on this particular driver's eye position, can also be established. As an example Figure 9 shows the direct visibility through the windscreen and nearside window of the DAF Mixer lorry. The ground came into view at a distance of approximately 4.4 metres directly ahead of the driver. The closest distance at which the ground can be seen through the nearside window from the driver's eye position in the DAF Mixer was approximately 7.4 metres from the nearside of the lorry (measured perpendicularly). In Figure 9 the surface shown shows the limits of the view between the driver's eye and the ground. Below the surface any part of an object, pedestrian or cyclist would not be directly visible to the driver. However, any part of an object, pedestrian or cyclist above the surface would be available to be seen. A cylindrical pole of 1.5 metres high has been placed 2.5 metres forward of the front of the lorry and with a further one 5 metres from the nearside of the lorry. This demonstrates that in these positions a proportion of the pole is available to be directly seen (above the plane) and a proportion is not available to be seen (below the plane) from the driver's eye position through the windscreen and nearside window. This image also shows the area obscured (blind spot) from the driver's eye position due to the nearside A-pillar obstruction and the blind spot caused by the nearside mirrors themselves.

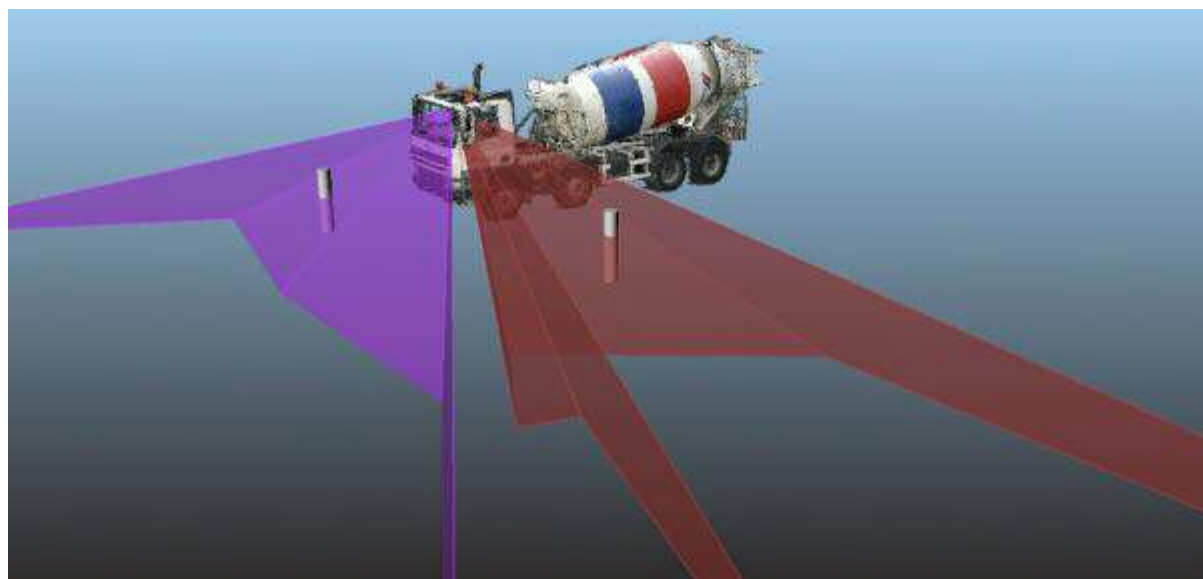

Figure 9: The direct view through the windscreen and side window for the DAF Mixer lorry and a photograph showing the A-pillar and mirror obstructions

Unlike for direct views, where a part of a person or object would need to be above the surface plane in the 3D model to be seen, for an indirect view through a mirror, part of a person or object would need to be within the areas to be seen. As previously noted, for this project the lorries assessed were all fitted with a Class II, large (plain) rearview mirror, a Class IV wide angle (convex) rearview mirror, a Class V side close proximity (convex) mirror and a Class VI front projection (convex) mirror. Figure 10 shows the four indirect mirror visibility zones measured for the DAF Tipper lorry.

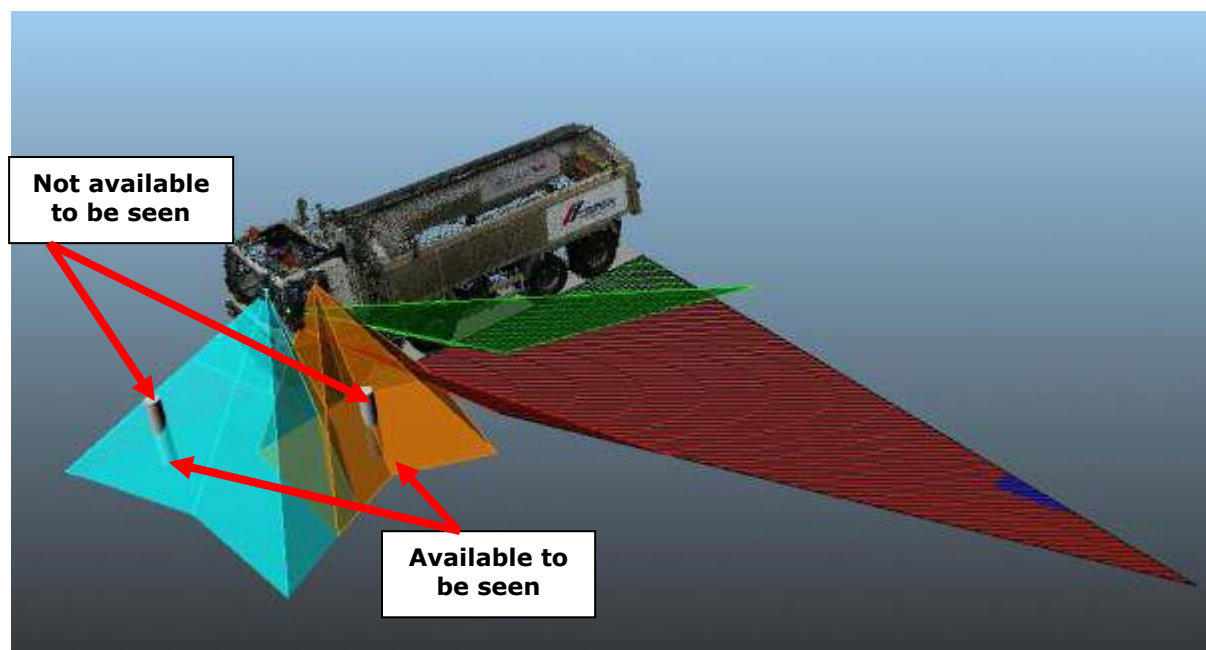

Figure 10: The visibility zones for the indirect (mirror) views for the DAF Tipper lorry

Two 1.5 metre high cylinders were placed in the three dimensional model of the indirect view of the DAF Tipper as shown in Figure 10. One was positioned 2.5 metres forward of the front of the vehicle in the front projection mirror zone and the second was positioned 2.0 metres from the nearside of the vehicle in the side close proximity mirror zone. The portion of the cylinder that is above the surface plane (light grey section of the cylinder) would not be available to be seen in the respective mirror. However, the lower section of the cylinder which is below the surface plane is available to be seen in the respective mirror.

It is possible that a proportion of an object, pedestrian or cyclist would be available to be seen by both an indirect view in the mirror and a direct view through the windscreen or side window.

As an example, the cylinder shown in Figure 11 is available to be seen in both the direct view through the windscreen and the front projection mirror. However, neither view will show the whole of the cylinder and thus only a proportion would be available to be seen by the driver.

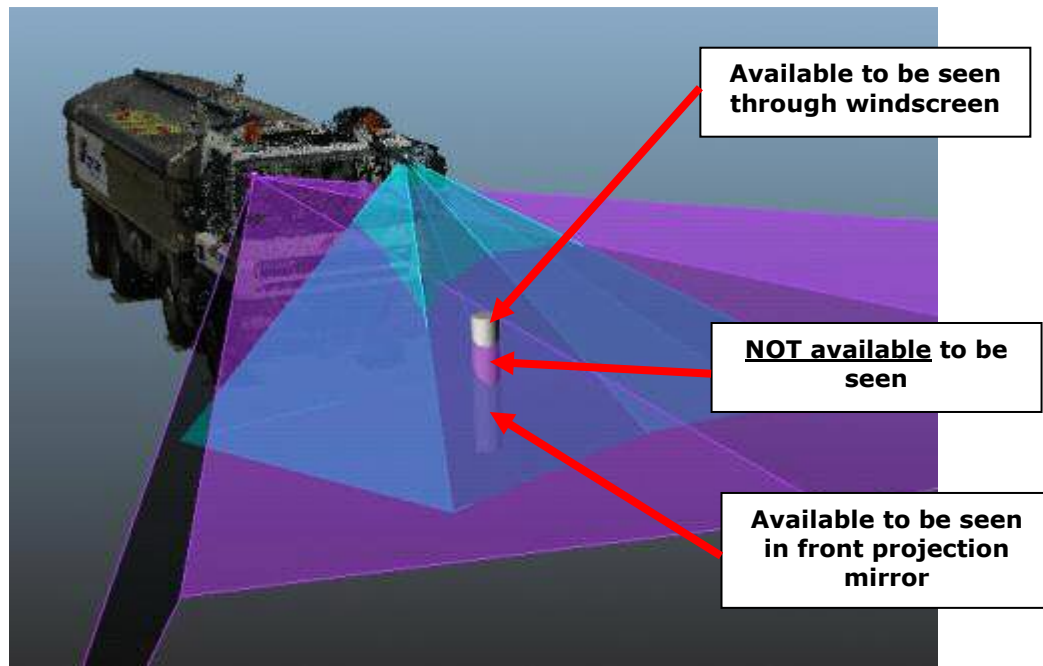

Figure 11: Demonstration that an object can be visible in both direct and indirect visibility

The mirrors fitted to the lorries aim to increase the field of view available to the driver and reduce the 'blind spot' areas around the vehicle. For example with the MAN curtain side lorry, it is possible for an object, pedestrian or cyclist to be out of sight in direct visibility in the area of the nearside A-pillar as shown in the left image of Figure 12. However, a proportion of the same cylinder would be available to be seen by the driver in both the front projection and close proximity mirrors as shown in the right image of Figure 12 as long as the driver looked in either of these mirrors. The light grey section of the cylinder is not visible at all.

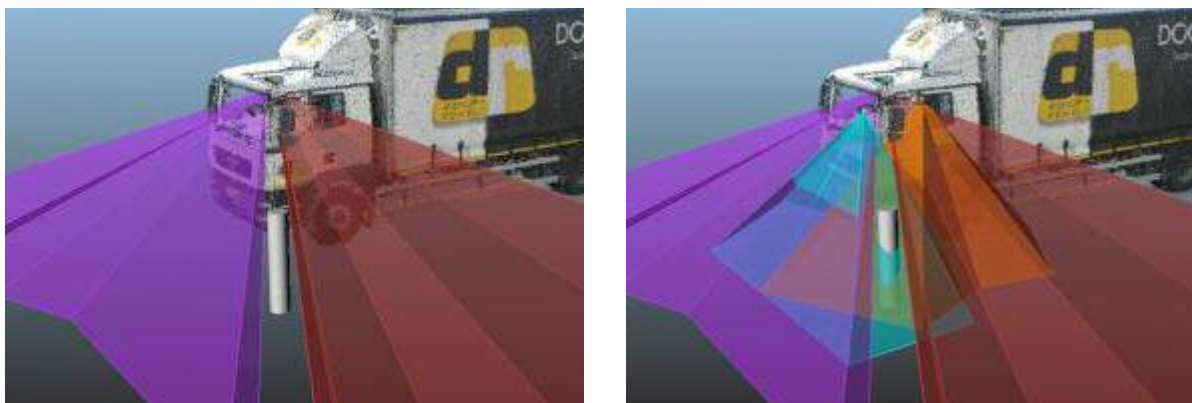

Figure 12: Image to show the mirrors reducing the 'blind spot' area at the front nearside corner of the MAN curtain side lorry. The light grey section of the cylinder is not visible in any view

The shape on the ground of the visible zone is a function of the object which is being traced around (for example the mirror or window frame) and it may appear elongated, larger and distorted when compared with the actual object. This is due to the perspective from which the driver's eye views the object and the distance and angle of the object to the ground. For example the lower edge of the nearside side window frame in the MAN

Curtain side lorry is shaped and appears to have a smooth 'step', however, when the effect of this is mapped on the ground the 'step' becomes more pronounced (Figure 13) and is larger than that noted on the door itself.



Figure 13: Image showing the effect of the 'step' shape in the window frame on the shape of the visible zone on the ground

5.3 The visible and non-visible zones for each vehicle

The process of assessing the direct and indirect visibility zones of each of the three lorries has been explained in the previous section. To enable each of the vehicles to be compared, it is firstly necessary to consider each of the lorries separately.

5.3.1 DAF CF Mixer (Cemex Vehicle)

To demonstrate the three dimensional visible and non-visible areas for the DAF Mixer the direct and indirect zones will be shown separately. Firstly for the direct view the windscreen, nearside side window and rear cab window were assessed. In Figure 14 the purple plane (ahead of the lorry) represents the lower and side boundary of direct visibility from the driver's eye position for the windscreen, the brown plane represents the lower and side boundary created by the nearside side window and the obstruction from the mirrors through this window and the blue plane represents the lower and side boundary for the rear cab window. In each of the images in Figure 14 the light grey section of the 1.5m tall grey cylinders would be available to be seen from the driver's eye position. Anywhere below the planes or outside of the side boundaries would not be visible.

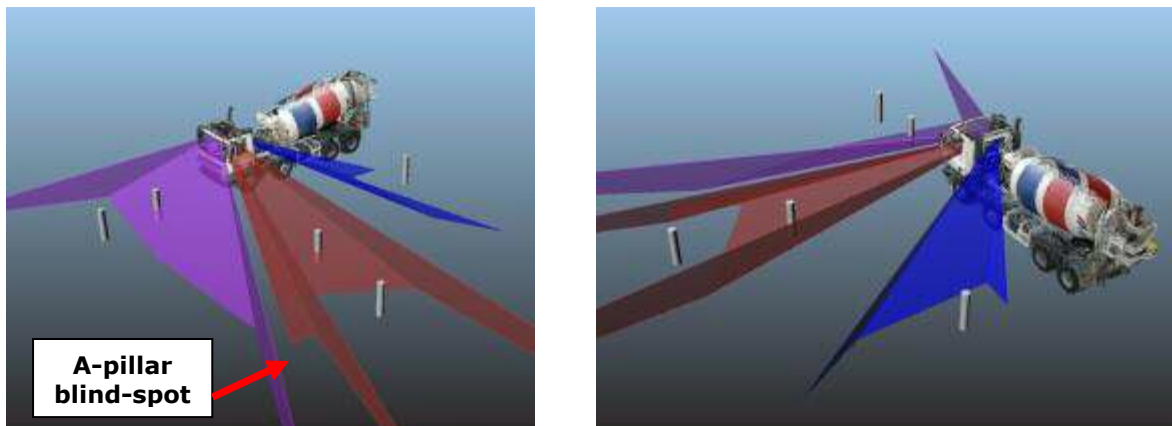

Figure 14: The lower and side boundaries of the visibility zones of the DAF Mixer measured from the windscreen (purple), nearside side window (brown) and the rear window in the cab (blue), the light grey sections of the cylinders are all directly visible

The indirect three dimensional visibility zones are shown in Figure 15 for the DAF Mixer. The light green plane represents the lower and side boundary of the area visible in the plain rear view mirror and the red plane shows the lower and side boundary of the wide angle rear view mirror. The boundary of the side close proximity mirror is shown in orange and the forward projection mirror nearside and lower boundary is shown in cyan. Both of the 1.5m tall cylinders that are positioned rearwards of the cab would be available to be seen in the wide angle mirror, however it would only be possible to see the cylinder towards the rear of the vehicle in the plain rear view mirror. The cylinder positioned at the front of the vehicle would be available to be seen in the front projection mirror, it may also be possible to see a proportion of this cylinder directly through the windscreen.

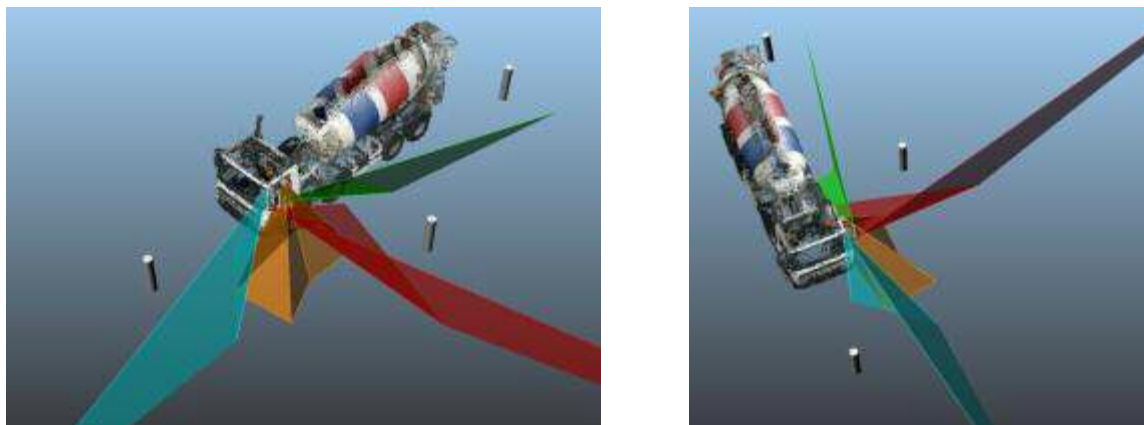

Figure 15: The lower and side boundaries of the indirect visibility zones of the DAF Mixer for the plain rear view mirror (green) and the wide angle rear view mirror (red). The whole boundary of the side close proximity mirror (orange) and the nearside and lower boundary of the front projection mirror (cyan)

To demonstrate the ground coverage of the visibility zones an area was mapped in the three dimensional model (Figure 16). The ground area shown in the model was an area of 16m x 18m, measured from the centreline of the vehicle towards the nearside and from the rear of the tipper lorry forwards. The rear of the tipper lorry was used as this was found to be the shortest of the three vehicles assessed (the assessed ground area stretched approximately 8.9m forward of all the lorries). The same area was used for all

the lorries to enable a comparison to be performed later in the report. The grey area shown in the images represents the area, at ground level, that is not visible from the driver's eye position in any direct or indirect view.

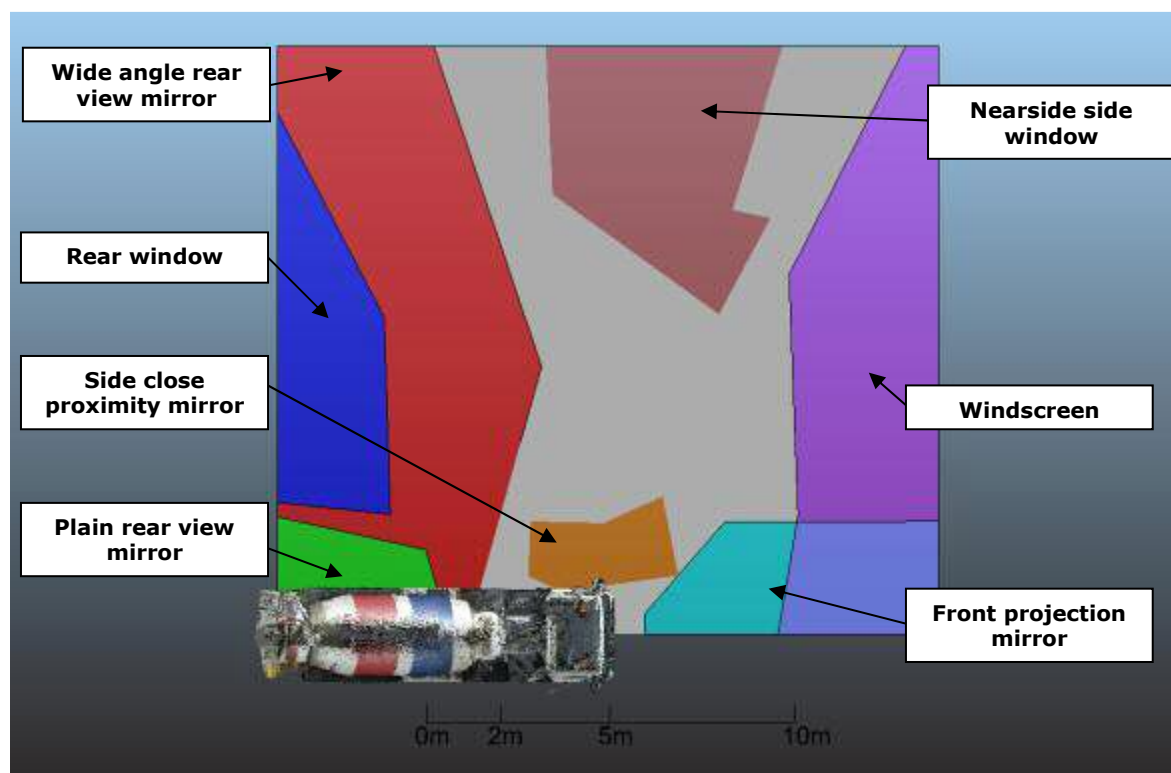

Figure 16: The visibility zones mapped on an area at ground level for the nearside half of the DAF Mixer vehicle (grey area of ground not visible)

For the assessed area shown above (Figure 16) it was possible to evaluate the proportion of the ground coverage of each mirror or direct view. These figures will then be used to compare the three vehicles. Due to the fact that some of the mirror zones overlap the total area coverage shown in Table 20 may sum to more than the area of the rectangle assessed (288m²). The area underneath the vehicle is not accounted for and therefore will be ignored.

Table 20: The areas of visible ground coverage within an area measuring 16m x 18m for the DAF Mixer lorry

Assessed Component	Ground Coverage Area
Windscreen	55m ²
Nearside side window	33m ²
Cab rear window	24m ²
Plain rear view mirror	6m ²
Wide angle rear view mirror	88m ²
Side close proximity mirror	7m ²
Front projection mirror	22m ²
Non visible area	85m ²

The images shown in Figure 17 are to demonstrate both the ground zone mapping and the three dimensional mapping of the visibility zones for the rear view mirrors and the nearside side window and windscreen.

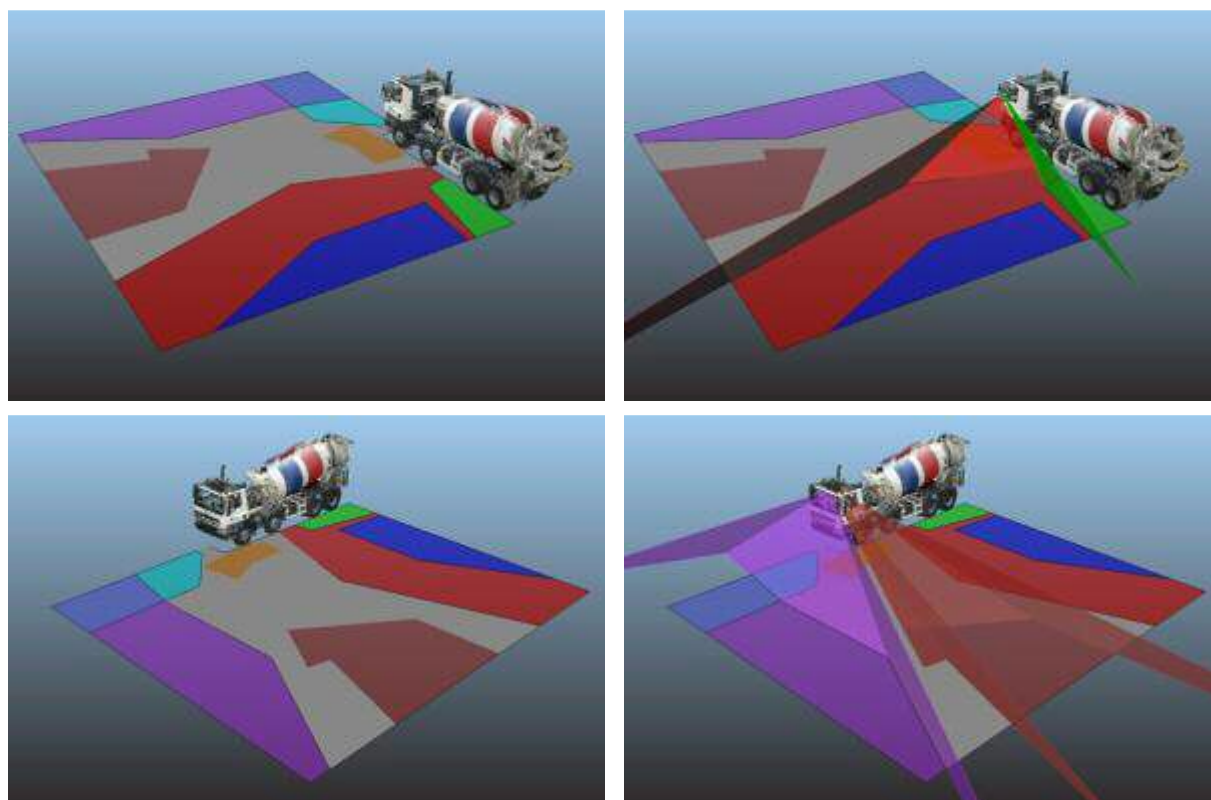

Figure 17: The images show a combination of the ground coverage and three dimensional modelling of the visibility areas for the rear view mirrors (top images) and the windscreen and nearside side window (bottom images) of the DAF Mixer

The ground map in Figure 16 shows that there is an area directly in front of the vehicle that is 'blind' to the driver in all views. Whilst the aim of the front projection mirror was to remove or minimise this blind spot, it is a function of the position of the mirror in this vehicle that causes this to occur.

The front projection mirror in the DAF Mixer assessed was positioned inside the vehicle. The fact that the mirror was rearwards of the front of the vehicle resulted in the base of the windscreen preventing the driver from being able to see the front of the lorry. Figure 18 shows a close up of the mirror (from the driver's eye position) showing that the front of the cab is not visible and the three dimensional effect in the model.



Figure 18: A photograph of the forward projection mirror fitted internally in the DAF Mixer showing that the front of the vehicle is not visible. The model shows the effect of the mirror being fitted rearwards of the front of the cab

The first point at which the ground becomes visible in the front projection mirror, is approximately 0.86 metres in front of the lorry at this particular driver's eye position. If a 0.3 metre diameter cylinder was placed directly in front of the lorry it would be able to be 1.22 metres tall and remain completely out of view of the driver (Figure 19). It is possible that the cylinder could be taller than this and remain out of sight to the driver due to the fact that the mirror is small in size and is convex so the objects at the edges are not as easy to distinguish.

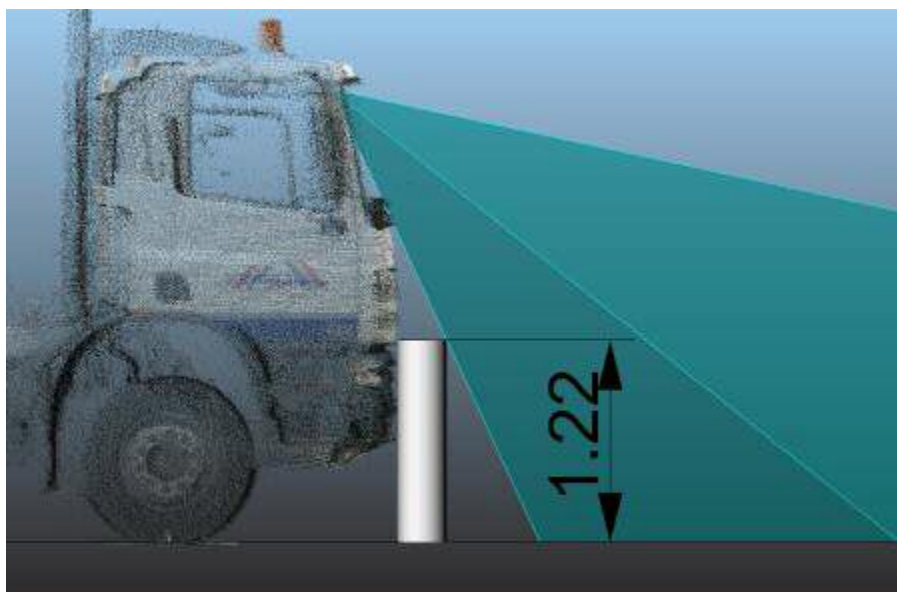

Figure 19: Image showing a 0.3m diameter cylinder positioned directly in front of the lorry and the height with which it could be to remain hidden from view in the front projection mirror

The nearside mirror configuration on the DAF Mixer was such that the plain rear view mirror was above the wide angle nearside mirror. When viewed through the nearside side window the mirrors themselves caused an obstruction to the view. The vehicle had also been fitted with a metal protective cover (Figure 20) that prevented the driver from being able to see between the mirrors and also from being able to see between the mirrors and the A-pillar/window frame. The effect of the obstruction from the mirrors is shown in Figure 16 where the brown area, which is the visible ground area through the nearside side window, is encroached upon by the grey area which is not visible.



Figure 20: The position of the nearside side mirrors and the obstruction caused by them and the metal protective cover

5.3.2 DAF CF Tipper (Cemex Vehicle)

The direct and indirect zones of visibility measured for the DAF Tipper will be shown in three dimensional format separately. Firstly, for the direct view, the windscreen, nearside side window and rear cab window were assessed. In Figure 21 the purple plane represents the lower and side boundary of visibility from the driver's eye position for the windscreen, the brown plane represents the lower and side boundary created by the nearside side window. The dark green plane represents the boundary of the obstruction in the direct view through the nearside side window from the nearside rear view mirrors. The blue plane represents the lower and side boundary for the rear cab window. In each of the images in Figure 21 the light grey section of the 1.5m tall grey cylinders would be available to be seen from the driver's eye position. Anywhere below the planes or outside of the side boundaries would not be visible.

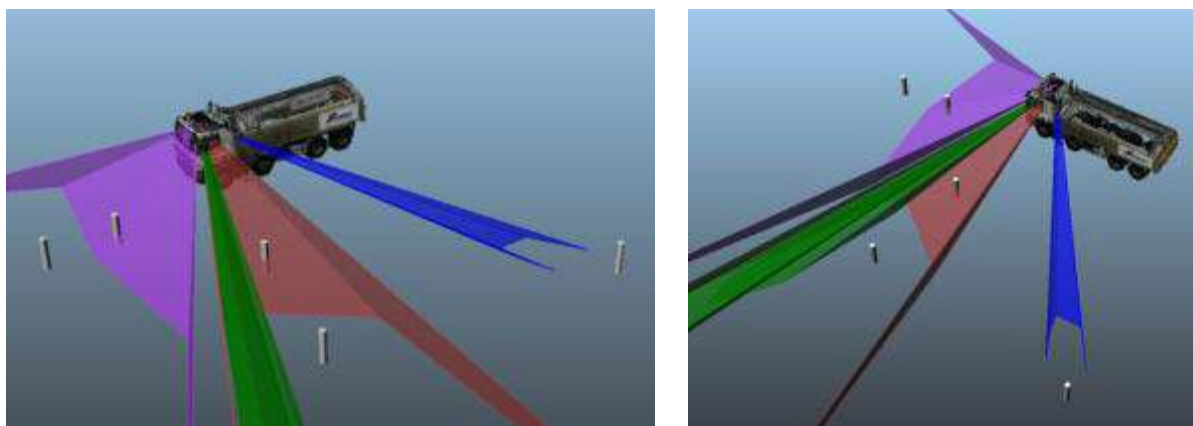

Figure 21: The lower and side boundaries of the direct visibility zones of the DAF Tipper measured from the windscreen (purple), nearside side window (brown) and the rear window in the cab (blue). The dark green enclosed plane is the obstruction in the direct view caused by the nearside mirrors

The three dimensional visibility zones measured for the indirect views are shown in Figure 22 for the DAF Tipper. The light green plane represents the lower and side boundary of the area visible in the plain rear view mirror, the red plane shows the lower and side boundary of the wide angle rear view mirror. The enclosed boundary of the side close proximity mirror is shown in orange and the forward projection mirror enclosed boundary is shown in cyan. The four 1.5m tall cylinders shown in Figure 22 would be visible within one or more of the mirrors. The two rearmost cylinders would both be visible in the wide angle rear view mirror. In the plain rear view mirror the only visible cylinder that would be that closest to the rear of the tipper. The cylinders wholly enclosed within the front projection and side close proximity zones would be visible completely within the front projection and side close proximity mirrors respectively. With the front projection mirror being positioned forwards of the vehicle on an extended arm and angled such that it is towards the front of the cab, the front of the vehicle was visible in the front projection mirror as shown in the three dimensional model, eliminating the blind spot directly in front of the vehicle.

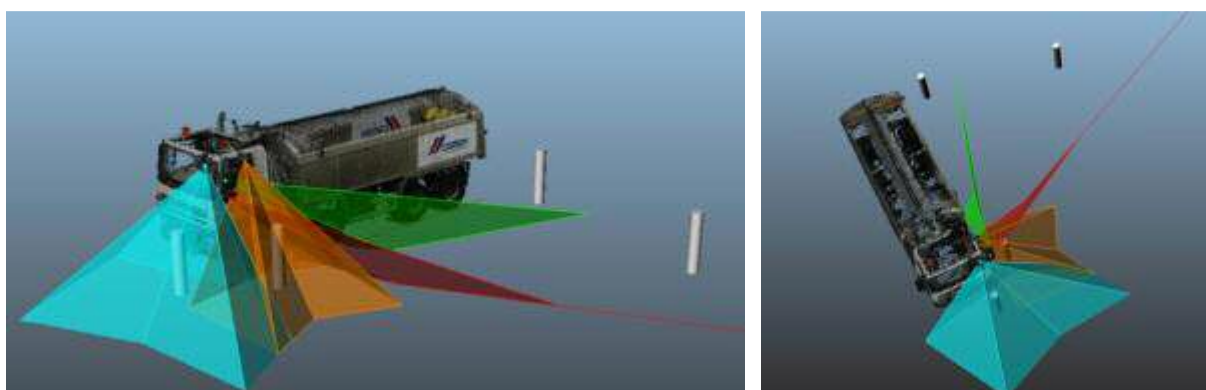

Figure 22: The lower and side boundaries of the indirect visibility zones of the DAF Tipper for the plain rear view mirror (green) and the wide angle rear view mirror (red). The whole enclosed boundary of the side close proximity mirror (orange) and the whole enclosed boundary of the front projection mirror (cyan)

The proportion of ground that the driver would have been able to see was assessed over an area of 16m x 18m for the DAF Tipper, measured from the centreline of the vehicle towards the nearside and from the rear of the tipper lorry forwards, (the tipper lorry was found to be the shortest of the three vehicles assessed). The assessed area stretched approximately 8.9m forward of the vehicle. The grey area shown in the images represents the area, at ground level, that is not visible from the driver’s eye position in any direct or indirect view (Figure 23).

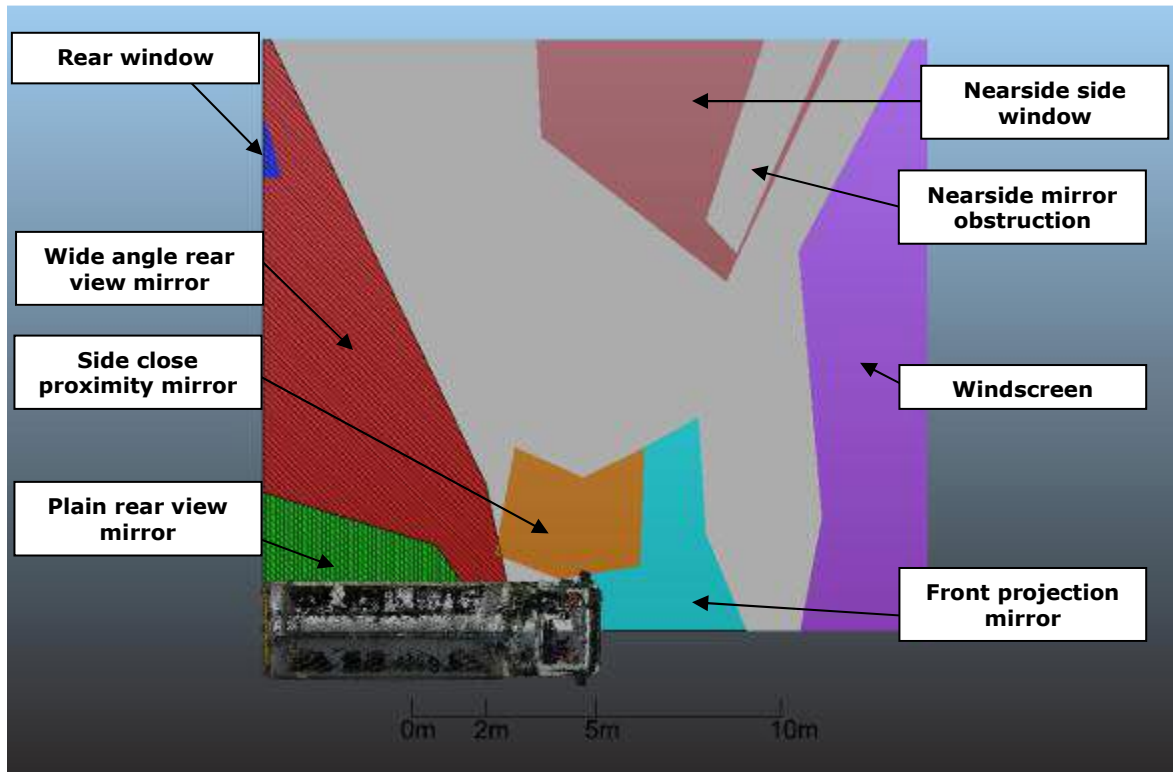

Figure 23: The visibility zones mapped on an area at ground level for the nearside half of the DAF Tipper vehicle (grey area of ground not visible)

The ground coverage of each mirror or direct view for the DAF Tipper is shown in Table 21. The area underneath the vehicle is not accounted for and therefore will be ignored.

Table 21: The areas of visible ground coverage within an area measuring 16m x 18m for the DAF Tipper lorry

Assessed Component	Ground Coverage Area
Windscreen	44m ²
Nearside side window	25m ²
Cab rear window	0.5m ²
Plain rear view mirror	9m ²
Wide angle rear view mirror	55m ²
Side close proximity mirror	11.00m ²
Front projection mirror	16m ²
Non visible area	130m ²

The images shown in Figure 24 demonstrate both the ground zone mapping and the three dimensional mapping of the visibility zones for the rear view mirrors, the windscreen, nearside side window, rear window and the side close proximity and front projection mirror.

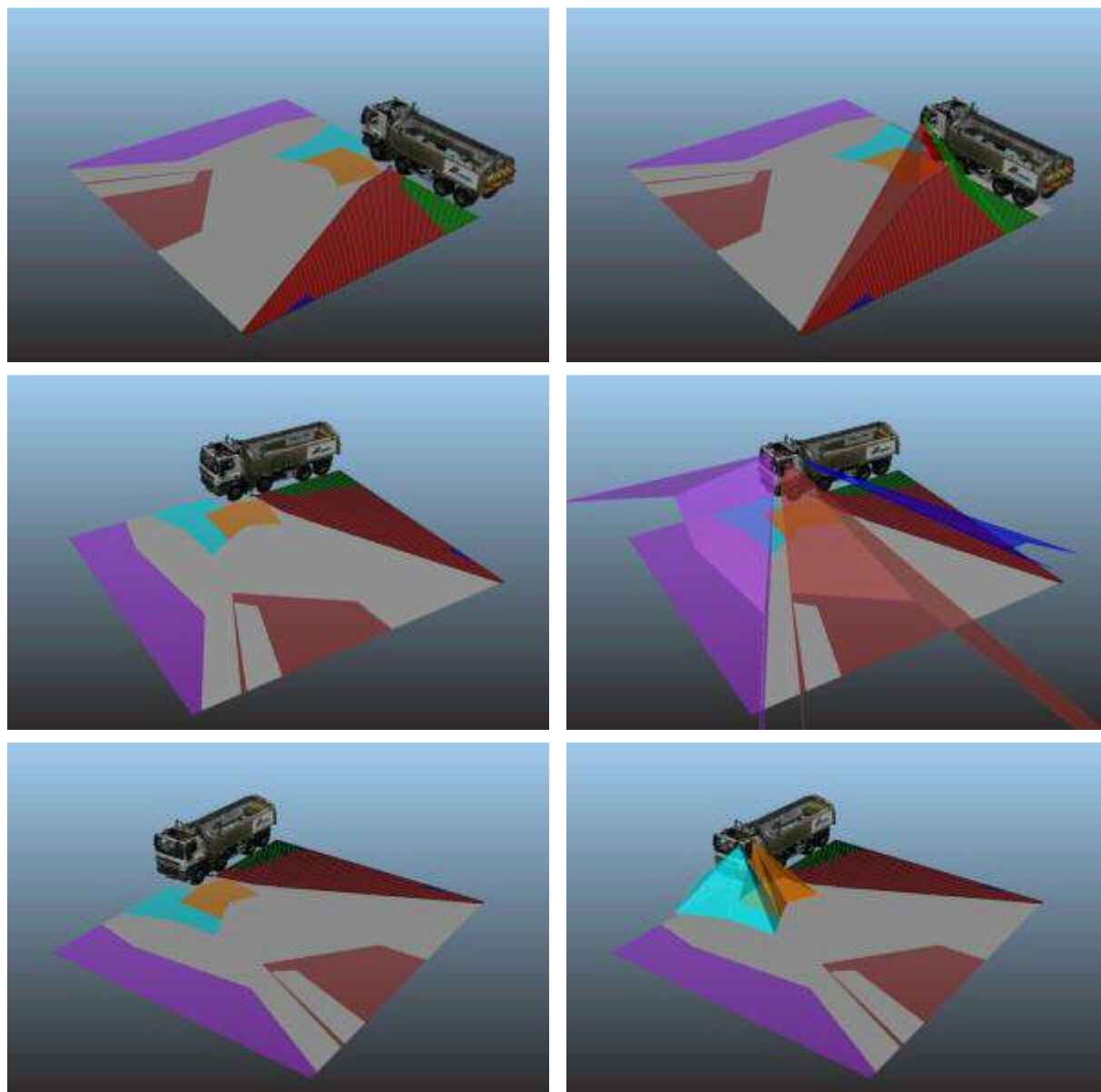

Figure 24: The images show a combination of the ground coverage and three dimensional modelling of the visibility areas for the rear view mirrors (top images), the windscreen, nearside side window and rear window (middle images) and the side close proximity and front projection mirrors (bottom images) of the DAF Tipper

The tipper that was assessed was fitted with a rear window in the cab; the visibility zone is shown (in blue) in three dimensional form in Figure 24 and the ground coverage in Figure 23. It was found that due to the tipper section of the vehicle, it was not possible to use the whole window to view the ground as shown in Figure 25.



Figure 25: A photograph of the view through the rear window of the DAF Tipper and the visibility zone through the window shown on the model

The nearside mirrors of the DAF Tipper were found to cause an obstruction from the driver's eye point when looking through the nearside side window. This occurs on all three vehicles assessed and is an inherent result of the position of the mirrors. However, the position of the mirrors on the DAF Tipper resulted in a small area between the mirror and the A-pillar/nearside side window frame being visible. The plain rear view mirror and the wide angle rear view mirror were in separate cowlings and thus there was a gap between the two mirrors as shown in Figure 26.



Figure 26: The photograph shows the gap between the plain rear view mirror (top) and the wide angle rear view mirror (bottom) on the DAF Tipper

The result of the gap between the mirrors and the A-pillar/window frame on the ground level visibility zone is shown in Figure 23 by the brown region. It is shown that the mirror obstruction (grey), which is caused by the lower wide angle rear view mirror, is enclosed by the brown ground visibility area mapped for the direct view through the nearside side window. The effect of the obstruction caused by the mirrors on the nearside is shown in three dimensional form in Figure 27, where the green zone is the area of obstructed view. The light section of the 1.5m tall cylinder shown in the image would be the only section visible from the driver's eye position in the gap between the two mirrors.

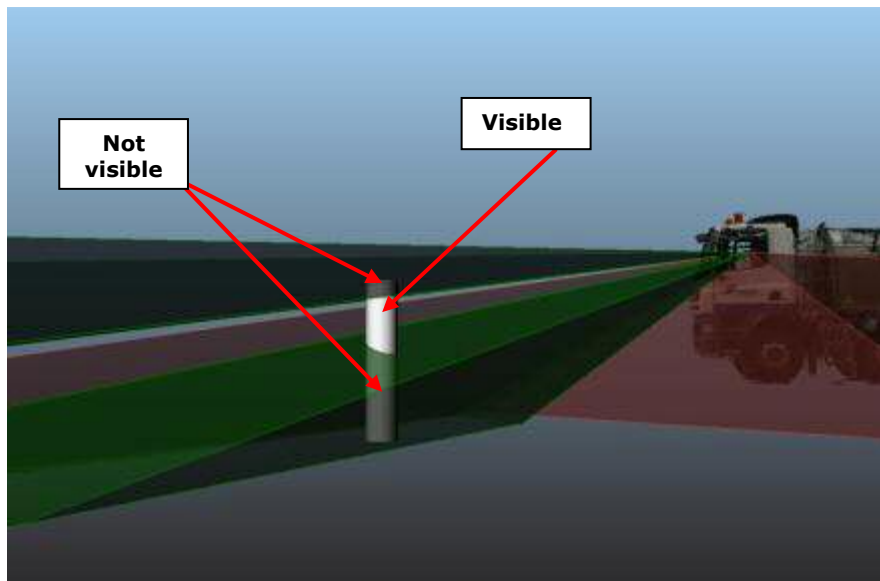

Figure 27: The effect of the obstruction caused by the mirrors on the nearside shown as the dark green zones. The light grey section of the cylinder is the only section that would be visible in this position between the two mirrors

5.3.3 MAN TGM26 Curtain side (Dooley Rumble Vehicle)

The direct and indirect zones of visibility measured for the MAN Curtain side will be shown in three dimensional format separately. Firstly for the direct view the windscreen and nearside side window were assessed, there was no rear window fitted to this vehicle. In Figure 28 the purple plane represents the lower and side boundary of visibility from the driver's eye position for the windscreen and the brown plane represents the lower and side boundary created by the nearside side window. In each of the images in Figure 28 the light grey section of the 1.5m tall grey cylinders would be available to be seen directly from the driver's eye position. Anywhere below the planes or outside of the side boundaries would not be visible directly.

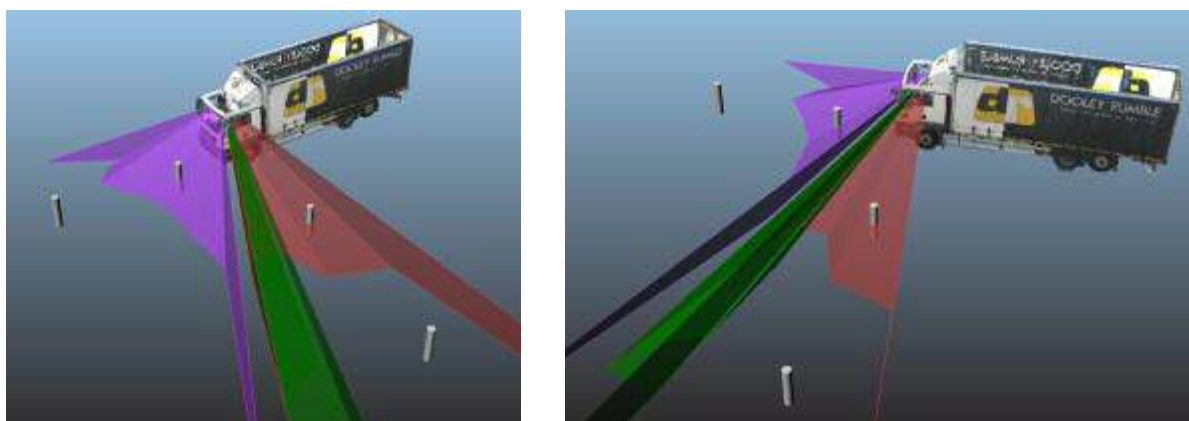

Figure 28: The lower and side boundaries of the direct visibility zones of the MAN Curtain side measured from the windscreen (purple) and the nearside side window (brown). The dark green enclosed plane is the obstruction in the direct view caused by the nearside mirrors

The three dimensional visibility zone measured for the indirect views are shown in Figure 29 for the MAN curtain side lorry. The light green plane represents the lower and side

boundary of the area visible in the plain rear view mirror and the red plane shows the lower and side boundary of the wide angle rear view mirror. The enclosed boundary of the side close proximity mirror is shown in orange and the forward projection mirror enclosed boundary is shown in cyan. The four 1.5m tall cylinders shown in Figure 29 would be visible within the mirrors. The two rearmost cylinders would both be visible in the wide angle rear view mirror. However, for the cylinder positions shown the only one that would be visible in the plain rear view mirror would be that closest to the rear of the curtain side lorry. The cylinders wholly enclosed within the front projection and side close proximity zones would be visible completely within the front projection and side close proximity mirrors respectively. The front projection mirror for the curtain side lorry was positioned forwards of the vehicle on an extended arm and angled such that it was towards the front of the cab. This position of this mirror resulted in the front of the vehicle being visible in the mirror from the driver's eye position as shown in the three dimensional model. As a result of this it contributed to eliminating the blind spot directly in front of the vehicle.

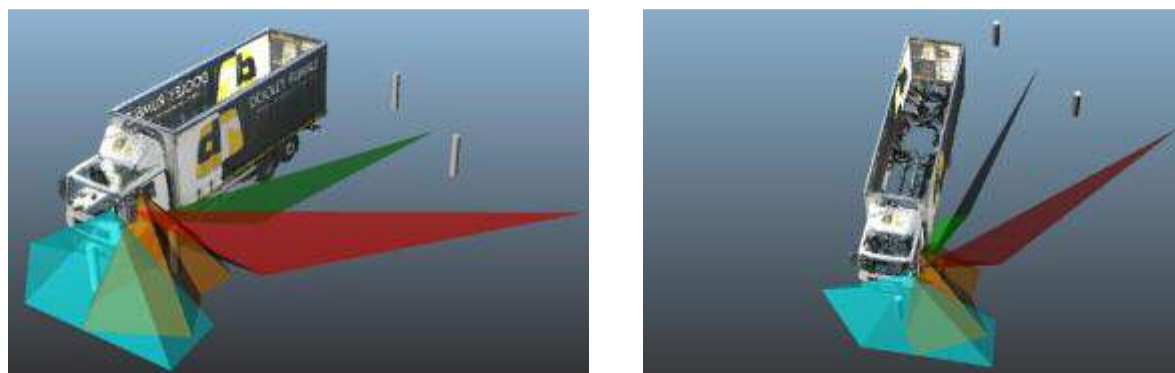

Figure 29: The lower and side boundaries of the indirect visibility zones of the MAN Curtain side for the plain rear view mirror (green) and the wide angle rear view mirror (red). The whole enclosed boundary of the side close proximity mirror (orange) and the whole enclosed boundary of the front projection mirror (cyan)

The proportion of ground that the driver would have been able to see was assessed over an area of 16m x 18m for the MAN curtain side lorry, measured from the centreline of the vehicle towards the nearside and from a point representative of the rear of the tipper lorry forwards, (the tipper lorry was found to be the shortest of the three vehicles assessed). The assessed area stretched approximately 8.9m forward of the vehicle. The grey area shown in the images represents the area, at ground level, that is not visible from the driver's eye position in any direct or indirect view (Figure 30).

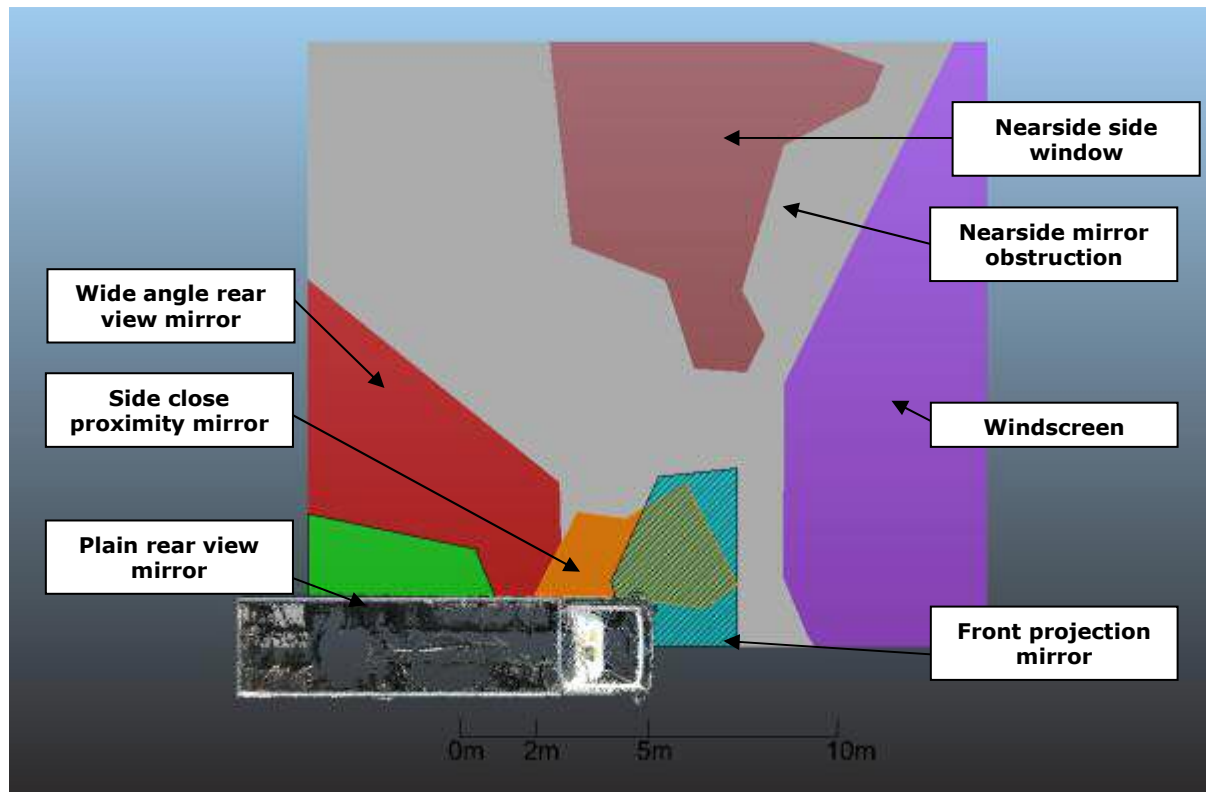

Figure 30: The visibility zones mapped on an area at ground level for the nearside half of the MAN Curtain side vehicle (grey area of ground not visible)

For the assessed area shown above (Figure 30) it was possible to evaluate the proportion of the ground coverage of each mirror or direct view as shown in Table 22. The area underneath the vehicle is not accounted for and therefore will be ignored.

Table 22: The areas of visible ground coverage within an area measuring 16m x 18m for the MAN Curtain side lorry

Assessed Component	Ground Coverage Area
Windscreen	65m ²
Nearside side window	43m ²
Plain rear view mirror	8m ²
Wide angle rear view mirror	39m ²
Side close proximity mirror	11m ²
Front projection mirror	12m ²
Non visible area	114m ²

The images shown in Figure 31 demonstrate both the ground zone mapping and the three dimensional mapping of the visibility zones for the rear view mirrors, the windscreen, nearside side window and the side close proximity and front projection mirror.

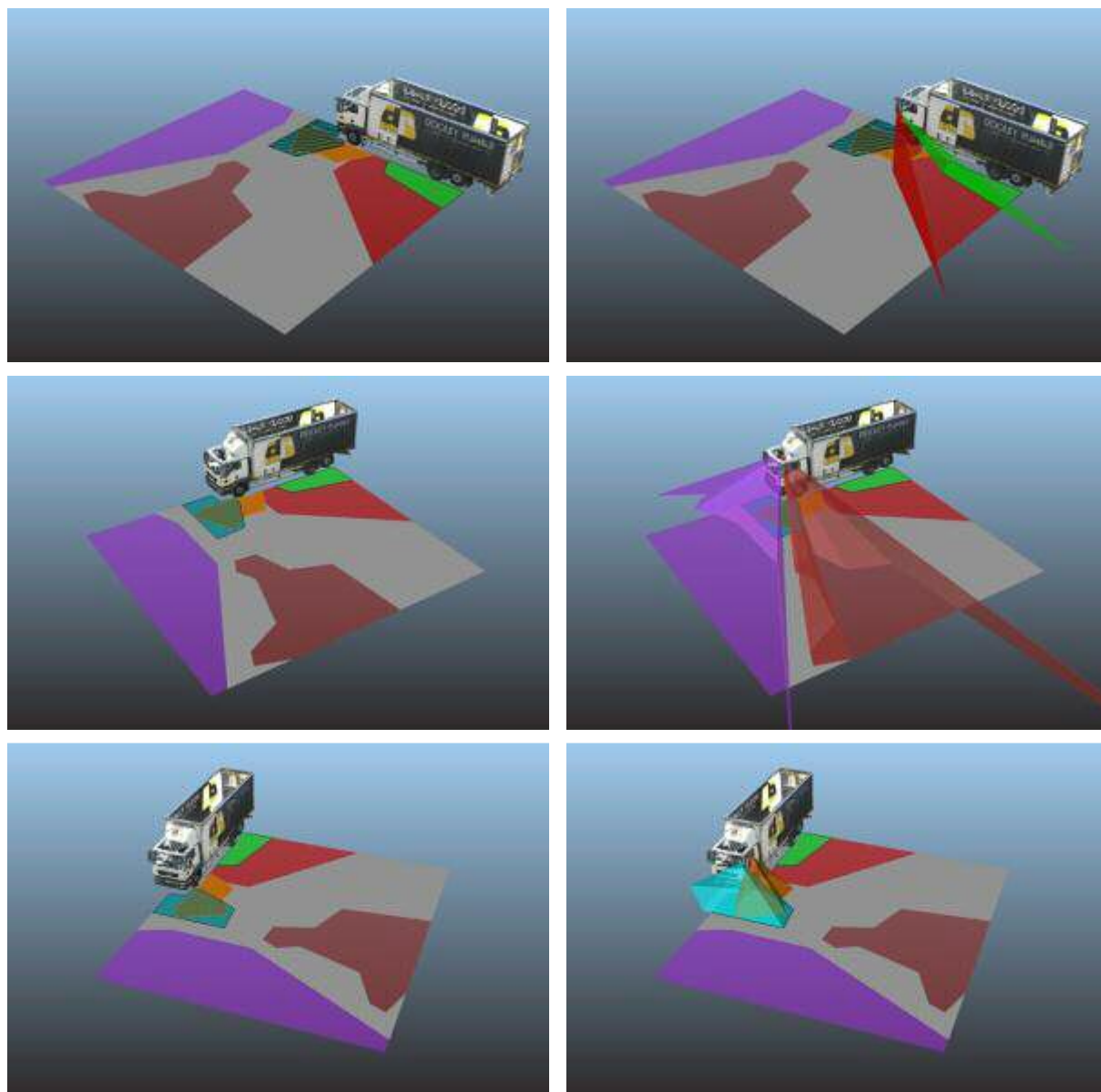

Figure 31: The images show a combination of the ground coverage and three dimensional modelling of the visibility areas for the rear view mirrors (top images), the windscreen, nearside side window and rear window (middle images) and the side close proximity and front projection mirrors of the MAN Curtain side

The rear view plain and wide angle mirrors fitted to the nearside of the MAN Curtain side lorry were in a position that caused an obstruction to the view through the nearside side window (Figure 32). There was found to be a gap (vertically) between the two mirrors through which it was possible for the driver to see the ground. The effect of the obstruction of the mirrors on the visible ground area is shown in Figure 30. The brown area represents the ground visible through the nearside side window and the obstruction to the view from the mirror is shown in grey where it encroaches into the brown area. The mirrors are positioned such that there is no gap visible from the driver's eye point between the side of the mirror and the A-pillar/window frame.



Figure 32: The nearside mirrors that were found to cause an obstruction to the view through the nearside side window of the MAN curtain side lorry

5.4 Comparison of the visibility zones

The process of assessing the visibility and the areas that are visible and not visible to the driver for each vehicle have been discussed in the sections above. To compare the three vehicles, the 16m x 18m section of ground demonstrated in the above sections will be compared. The areas at ground level that were visible and those that were not, for the DAF Mixer, DAF Tipper and MAN Curtain side were shown in Figure 16, Figure 23 and Figure 30 respectively. The ground level area of each of these zones was calculated in the computer model, the results of which have been consolidated into Table 23 below.

The assessed component of the vehicle that provides the largest visible area and the smallest non visible area from the drivers eye point for the 16m x 18m ground area have been highlighted in Table 23 to show which of the three vehicles provides the greatest visibility area. In Table 23 it is possible to see that the MAN Curtain provides the largest visible area for this specified section of ground in terms of direct view through the windscreen and nearside side window. The DAF mixer has the largest visible ground area with regard to the view from the cab rear window, however it is believed that this is due to the shape of the mixer component of the vehicle when compared with the large box section of the tipper vehicle.

The wide angle rear view mirror of the DAF Mixer lorry shows a considerably larger area of ground that is visible in the mirror than any of the other vehicles. However, it is believed that this is a function of how the driver had positioned the mirror. The area coverage for the front projection mirror was found to be greatest in the DAF Mixer. This was believed to have occurred due to the position of the mirror, in that it was an internally fixed mirror which projected a forward image rather than the mirrors fitted to the DAF Tipper and MAN Curtain side which were externally fitted and were angled to show the front of the vehicle. Consequently although it appears that the DAF Mixer provides a larger visible coverage area for this assessed section of ground it must be considered whether the area of ground that is actually visible is suitable. For example

the front of the vehicle is not visible in the mirrors of the DAF Mixer and thus a blind spot occurs, in addition the extent (width) of the wide angle mirror zone may be futile as the area of concern around the vehicle is within 1-2 lane widths from the side of the vehicle.

Table 23: The areas of visible ground coverage within an area measuring 16m x 18m for the three assessed lorries

Assessed Component	Ground Coverage Area		
	DAF Mixer	DAF Tipper	MAN Curtain
Windscreen	55m ²	44m ²	65m ²
Nearside side window	33m ²	25m ²	43m ²
Cab rear window	24m ²	0.5m ²	N/A
Plain rear view mirror	6m ²	9m ²	8m ²
Wide angle rear view mirror	88m ²	55m ²	38m ²
Side close proximity mirror	7m ²	11m ²	11m ²
Front projection mirror	22m ²	16m ²	12m ²
Non visible area	85m ²	129m ²	114m ²

As mentioned above, the figures shown in Table 23 may not truly represent which of the assessed vehicles has the most appropriate mirrors or visible area. This is because the environment where these vehicles are used is in the urban area where the space alongside the vehicle is limited to, for example, the width of one lane. Therefore, to consider the effect of the assessed vehicle being in lane two of a two lane carriageway, an area of 4 metres to the nearside of the vehicle has been considered (assumes a lane width of 3.5m and 0.5m from the vehicle in lane 2 to the lane separation line). For the purposes of the assessment the same sized area was considered for each vehicle, for example the assessed area was 18m in length (8.9m in front of the vehicle) and 5.25m in width (4m from the nearside of the vehicle and then to the centreline of the vehicle) with the section under the vehicle being ignored. The three assessed areas are shown in Figure 33 below.

Dark blue: View through rear window

Green: Plain rear view mirror

Red: Wide angle rear view mirror

Orange: Side close proximity mirror

Light blue: Front projection mirror

Purple: Windscreen direct view

Grey: Not directly or indirectly visible at ground level

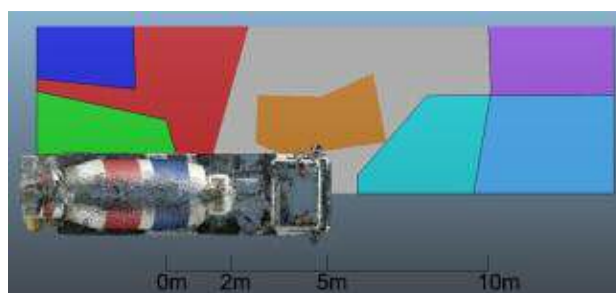

DAF Mixer
(21m² grey area)

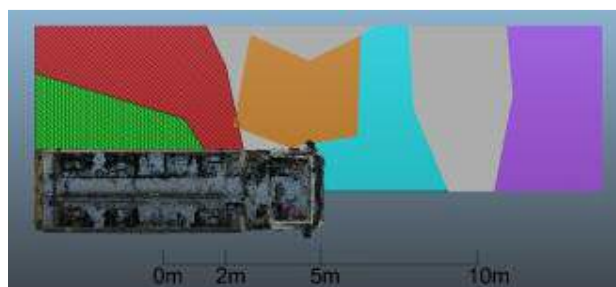

DAF Tipper
(19m² grey area)

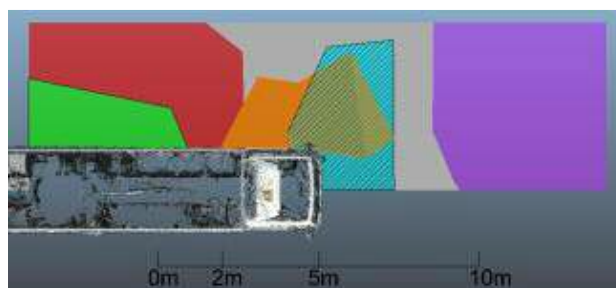

MAN
Curtain side
(14m² grey area)

Figure 33: The ground level visibility coverage area assessed over an area of 4m to the nearside of the vehicle, replicating a road lane width to the nearside

The area of each of the zones highlighted in Figure 33 was calculated in the computer program and the results of which have been collated in Table 24.

Table 24: The areas of visible ground coverage for a representative lane one when the assessed vehicle is in lane two

Assessed Component	Ground Coverage Area		
	DAF Mixer	DAF Tipper	MAN Curtain
Windscreen	21m ²	16m ²	28m ²
Nearside side window	0m ²	0m ²	0m ²
Cab rear window	5m ²	0m ²	N/A
Plain rear view mirror	6m ²	9m ²	8m ²
Wide angle rear view mirror	24m ²	25m ²	26m ²
Side close proximity mirror	7m ²	11m ²	11m ²
Front projection mirror	22m ²	16m ²	12m ²
Non visible area	21m ²	19m ²	14m ²

By assessing a 'lane one nearside danger area' only, it is possible to see from the above table that the difference between the three vehicles reduces. The visible area in direct

view through the windscreen in the lane one 'danger' assessment was found to be greatest in the MAN curtain side lorry, as before. The design of the vehicle dashboard and windscreen contributes to the view available through the windscreen. The MAN curtain side lorry is the newest of the three vehicles assessed and thus it is possible that it has benefitted from design improvements to increase the visible area. The DAF Tipper is however, the vehicle which provides the least visible ground zone for the assessed area through the windscreen. One potential explanation for this is the height of the driver with respect to the ground. The driver's eye point for the DAF Tipper is higher than that of the DAF Mixer and MAN Curtain side, consequently for the same height driver and similar shaped dashboard the first point at which the driver will be able to see the ground in front of the vehicle in the DAF Tipper will be further away. A simple demonstration of the effect of the height of the vehicle on the first point the ground is visible is shown in Figure 34. The line drawing of the lorry has the lower boundary line of sight through the windscreen estimated and then the same vehicle has been raised to show that the distance forward of the vehicle increases as the height is raised, assuming the same height driver and the same vehicle design.

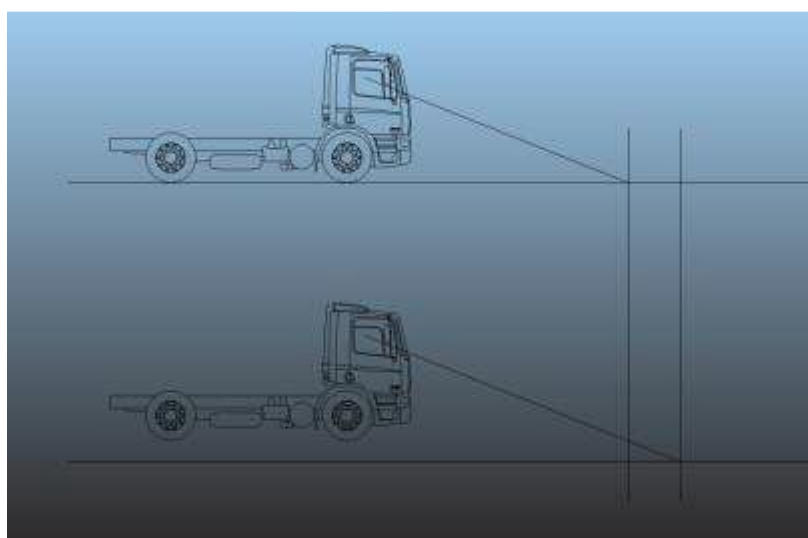

Figure 34: Simple example of the effect of a higher vehicle on the position that the ground first becomes visible

The images in Figure 33 do not show any visibility zone for the nearside side window due to the ground not being visible within four metres of the nearside of the vehicle, this was found to occur in all three of the assessed lorries. The size of the visible ground area in the plain rear view mirror has not changed between the two assessments due to this zone not extending beyond the four metre assessment area away from the side of the lorry. In the larger ground area assessment it was found that the visible ground area in the wide angle mirror zone was largest for the DAF Mixer, followed by the DAF Tipper and then the MAN curtain side. However, when the lane one area only was considered, it was found that order reversed and the MAN curtain side had the largest visible ground area, followed by the DAF Tipper and then the DAF Mixer. A reason for this is that the shape of the visibility zones for the wide angle rear view mirror differs slightly between the three vehicles within the lane one area.

The small sample of vehicles tested makes it difficult to generalise the findings to all construction vehicles – however the results can be taken as indicative of areas that warrant further investigation.

The DAF Mixer was found to cover the largest area with regard to the ground coverage for the front projection mirror. However, the position of the front projection mirror for this vehicle is the main reason that the visibility area is large. The mirror being positioned rearwards of the front of the vehicle results in the mirror projecting the area forwards of the vehicle and thus the view in the mirror is theoretically endless. However, it is unlikely that the driver of the vehicle will use the mirror to view objects forward of the point where the ground first becomes visible through the windscreen. Consequently, if the ground area visible through the front projection mirror between the front of the vehicle and the point where the ground is visible through the windscreen only is assessed for the front projection mirror then this area reduces to approximately 9.5m² as shown in Figure 35 (highlighted by the yellow line). In addition the position of the front projection mirror in the DAF Mixer results in an area directly in front on the vehicle not being visible. Although this area is relatively small there is the possibility that a pedestrian would be able to walk in front of the vehicle and not be visible in any view. The front projection mirrors of the DAF Tipper and MAN Curtain side were both externally mounted on an extended arm and were angled such that the front of the vehicles were visible in the mirror removing the blind spot in front of the vehicles.

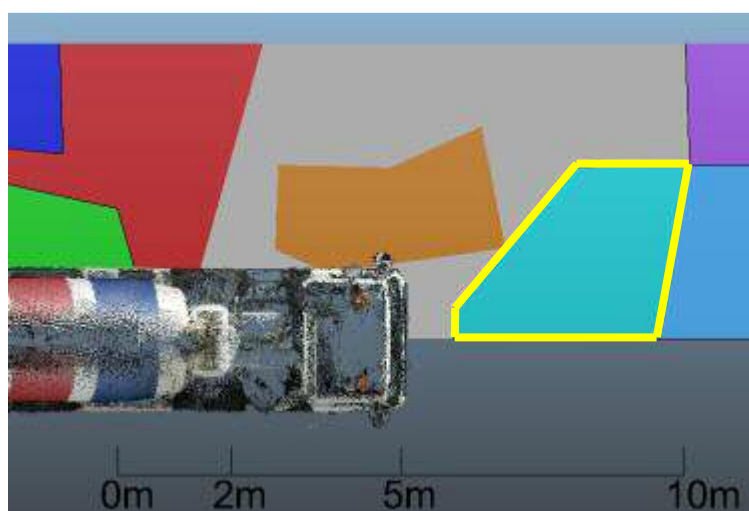

Figure 35: The area of ground that is visible in the front projection mirror between the front of the DAF Mixer and the first point the ground is visible through the windscreen, highlighted by the yellow border line

All of the three vehicles assessed have areas of the ground to the nearside and front that are not visible through the windows or by using the mirrors.

Obviously, the smaller the area of ground that is not visible, the more likely it is that the driver of the vehicle will be able to see any object however small it is within the roadway. Therefore, in the assessment of the 'lane one danger area' as shown in the above images the MAN Curtain side lorry was found to have the smallest area of ground that was not visible to the driver.

The key finding resulting from this assessment is that the construction vehicles which were scanned have larger blind spots than the haulage curtain sider.

The assessment of the ground area is purely a two-dimensional assessment and does not consider the fact that it would be possible for an object, pedestrian or cyclist to be within the non-visible area of ground but with a proportion of them still visible in the three dimensional zone of the planes of view. The next section of the report considers

the possibility of a cyclist being along the nearside of the vehicle and discusses a cyclist being in the non-visible ground area.

5.5 The potential of being able to 'see' a cyclist

To consider the potential of a driver being able to see a cyclist positioned along the nearside of the vehicle or within 'lane one', a three dimensional model of a cyclist was placed approximately 1m and then 3m from the nearside of the vehicle. The model of the cyclist used was approximately 1.5m tall when sitting on a bicycle and is shown in Figure 36.



Figure 36: The three dimensional model of the cyclist used for the assessment. The cyclist is 1.5m tall when sitting on the bicycle

The cyclist was positioned at 1m intervals along the side of the lorry with the front wheel aligned with the front of the vehicles (positions 7 and 8) as shown for the DAF Tipper in Figure 37. Each position has been numbered for reference purposes.

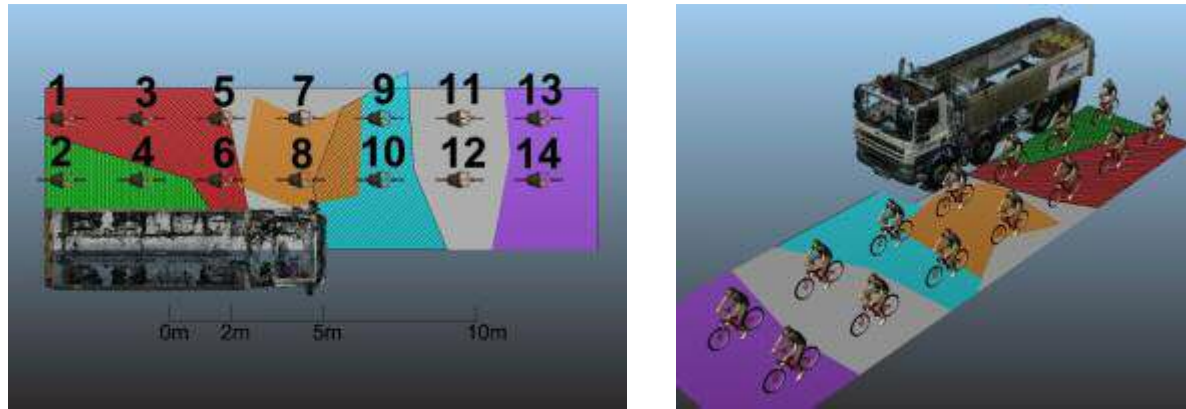

Figure 37: The positions of the cyclist considered during the assessment, the two rows of cyclists are 1m and 3m away from the nearside of the vehicle respectively

To determine whether a cyclist of 1.5m height would be visible to the lorry driver, the three dimensional visibility zones were considered in addition to the ground plane zones.

5.5.1 DAF Mixer

Table 25 shows which cyclists would be visible in the particular zones for each component assessed for the DAF Mixer, based on the positions of the cyclist as shown in Figure 37.

Table 25: A summary of the cyclists that would be visible (wholly or a proportion thereof) for each viewing component of the DAF Mixer. The cyclist was 1.5m tall in this assessment

Component	Image	Cyclist position visible [(x) denotes that a proportion of cyclist is visible]
Plain rear view mirror		<p>2, 4, (6)</p> <p>There would only be a right shoulder of the cyclist visible in position 6</p>
Wide angle rear view mirror		<p>1, 2, 3, 4, 5, (6), (7)</p> <p>The lower section of the front wheel would not be visible in position 6. The back of the cyclist would be visible in position 7.</p>

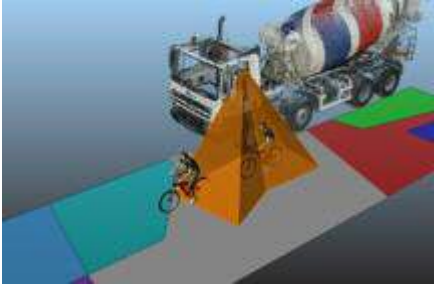
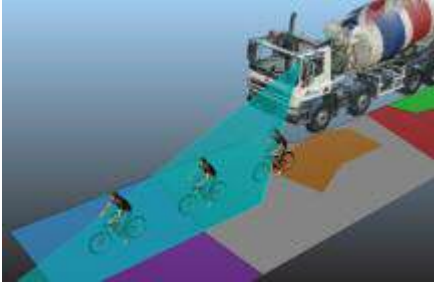
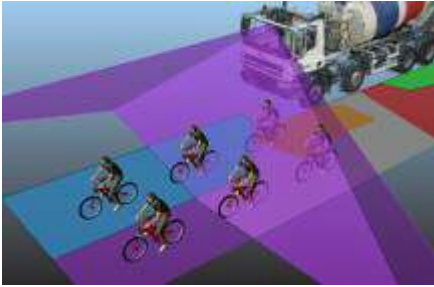
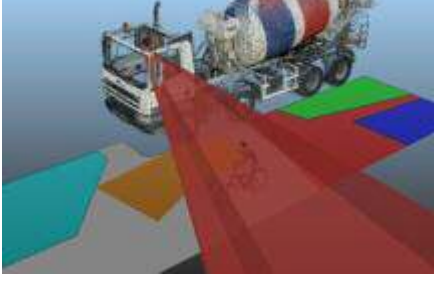
Component	Image	Cyclist position visible [(x) denotes that a proportion of cyclist is visible]
Side close proximity mirror		<p>(8), (10)</p> <p>The head and left shoulder and arm would not be visible in position 8. The rear lower section of the bicycle only would be visible in position 10</p>
Front projection mirror		<p>(10), (12), (14)</p> <p>The front wheel and right shoulder only would be visible in position 10. The lower section of the cyclist only would be visible in positions 12 and 14</p>
Windscreen		<p>(9), (10), (11), (12), 13, 14</p> <p>The head only of the cyclist was visible in positions 9 and 10. The lower section of the rear wheel would not be visible in positions 11 and 12</p>
Nearside side window		<p>(7)</p> <p>Only the top section of the head of the cyclist would be visible</p>

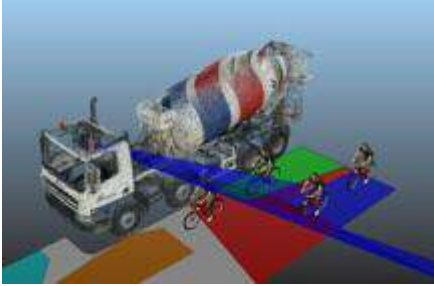
Component	Image	Cyclist position visible [(x) denotes that a proportion of cyclist is visible]
Rear cab window		<p>1, (3), (4), (6)</p> <p>The front lower section of the front wheel not visible in position 3. Only the left handle bar visible in position 4. Only the head visible in position 6</p>

The table and images show that it is possible for the cyclist to be positioned in such a manner that it is in the area of ground that is not visible to the driver but yet a proportion of the cyclist (above the ground level) would still be visible due to the height and angle of the visibility planes. However, it is likely that the less of a proportion of an object that is visible in the zone the more difficult it is for a driver to perceive what it actually is and whether it is actually a hazard. For example with the cyclist in position 7 (Figure 38) the top of the cyclist’s head appears to be visible at the bottom of the nearside side window for this height of cyclist and particular eye position of the driver.

Whilst the top the head is there to be seen it is possible that the driver would not perceive the object as a pedestrian or cyclist, and thus may not interpret that as a hazard.

In addition the convex mirrors used can distort the image and this can be more pronounced towards the edges of the mirrors. Consequently, whilst objects may be ‘visible’ at the perimeter of the zones, caution would need to be used in stating how ‘well perceived’ the cyclist was to the driver.

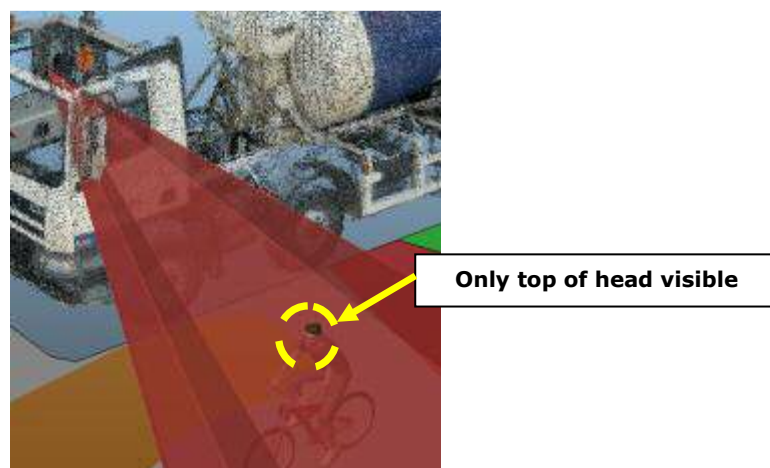

Figure 38: The cyclist in position 7 showing that for the DAF Mixer the top of the head only is visible of a cyclist 1.5m tall

It was shown in Table 25 that the cyclist was partially available to be seen in position 10 in three different view components, these being the side close proximity mirror, the front

projection mirror and the windscreen. However, none of the views show the whole cyclist in this position (Figure 39), for example the head only is visible in the windscreen, the front wheel and right shoulder in the front projection mirror and the rear lower section of the wheel in the side close proximity mirror. Consequently, whilst the cyclist is available to be seen in three views, it is only a proportion that is available and thus it is possible that the driver of the vehicle may not be able to perceive and distinguish the cyclist. It is most likely that this would be the case for the close proximity mirror and front projection mirror views due to the convex shape of the mirror distorting the object image.

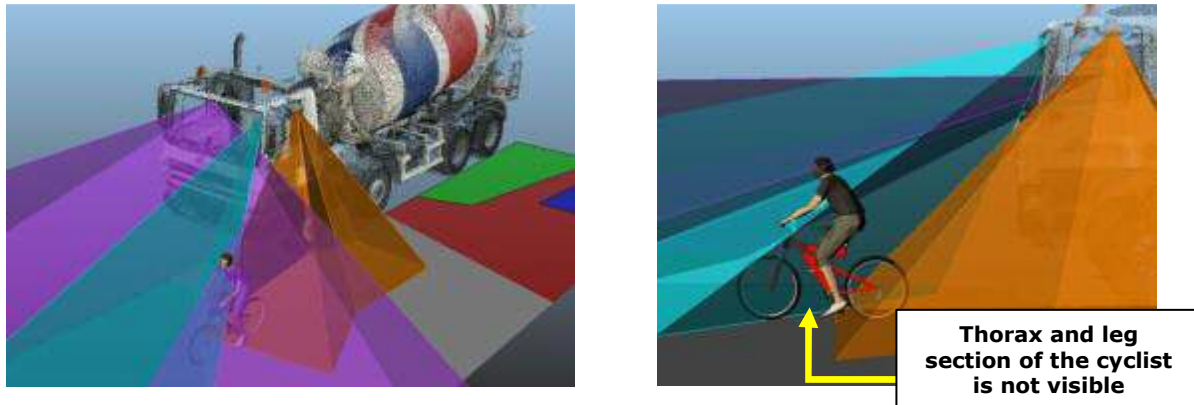
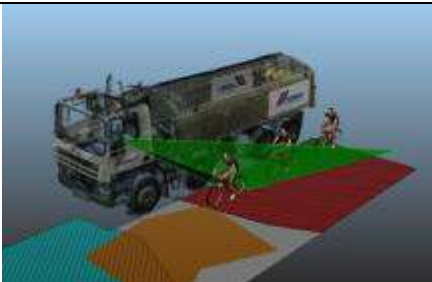

Figure 39: The cyclist in position 10, showing that a proportion of the cyclist is visible in the windscreen, close proximity and front projection mirrors for the DAF Mixer.

5.5.2 DAF Tipper

For the DAF Tipper lorry it was found that when the cyclist was positioned as per the image shown in Figure 37 the cyclist was visible in the zones as in shown in Table 26.

Table 26: A summary of the cyclists that would be visible (wholly or a proportion thereof) for each viewing component of the DAF Tipper. The cyclist was 1.5m tall in this assessment

Component	Image	Cyclist position visible [(x) denotes that a proportion of the cyclist is visible]
Plain rear view mirror		<p>2, 4, (6)</p> <p>There would only be a right shoulder of the cyclist visible in position 6</p>

Component	Image	Cyclist position visible [(x) denotes that a proportion of the cyclist is visible]
Wide angle rear view mirror		<p>1, 2, 3, 4, (5), 6</p> <p>The lower section of the front wheel would not be visible in position 5.</p>
Side close proximity mirror		<p>(6), (7), 8 (9)</p> <p>The front edge of the wheel would be visible in position 6. The rear lower section of the rear wheel only would be visible in position 7 and 9</p>
Front projection mirror		<p>(8), (9), (10)</p> <p>The front wheel only would be visible in position 8. The lower section of the cyclist only would be visible in positions 9 and 10</p>
Windscreen		<p>(9), (11), (12), 13, 14</p> <p>The forehead only of the cyclist was visible in position 9. The lower section of the bicycle would be visible in positions 11 and 12 and 12</p>
Nearside side window		<p>No position of the cyclist is visible</p>

As with the analysis of the DAF Mixer, it was found that for the DAF Tipper the cyclist was able to be positioned in an area where the ground is not visible yet the cyclist (or a proportion of) was still available to be seen. The instances where the proportion of the cyclist in the visible zone is small may result in the driver not being able to identify the object and determine whether it is a hazard. For example, when the cyclist was placed in position 9 the only section of a cyclist at this height that would be visible through the windscreen would be the forehead (Figure 40) in the nearside lower corner of the windscreen.

However, although the visibility assessment provides straight, clean lines at the boundaries of the visibility zones it is likely that at the edges it is more difficult for the driver to identify an object and slight movement of the head of the driver or cyclist could increase or further decrease the proportion of the object, cyclist or pedestrian that was visible.



Figure 40: The 1.5m tall cyclist in position 9 showing the small area of forehead that is potentially visible in the lower nearside corner of the windscreen of the DAF Tipper

For the DAF Tipper it was found that the cyclist in position 7 was not visible directly through the nearside side window. The increased ride height of the vehicle resulted in the driver not being able to see the ground as close to the vehicle as for the other two vehicles and therefore resulted in a larger blind spot for the nearside side window. The issue was resolved slightly with the fact that the side close proximity mirror covered a wider ground area (to the nearside) than the two other vehicles assessed and this resulted in the lower section of the rear wheel of the cyclist in position 7 being available to be seen in this view.

5.5.3 MAN Curtain side

Table 27 shows which cyclists would be visible in the particular zones for each of the components assessed for the MAN Curtain side. The positions of the cyclist relate to the image shown in Figure 37.

Table 27: A summary of the cyclists that would be visible (wholly or a proportion thereof) for each viewing component of the MAN Curtain side lorry. The cyclist was 1.5m tall in this assessment

Component	Image	Cyclist position visible [(x) denotes that a proportion of cyclist is visible]
Plain rear view mirror		<p>2, 4, (6)</p> <p>There would only be the right half of the cyclist visible in position 6</p>
Wide angle rear view mirror		<p>1, 2, 3, 4, (5), 6</p> <p>The left arm and handlebar would not be visible in position 5.</p>
Side close proximity mirror		<p>(8), (10)</p> <p>The left shoulder would not be visible in position 8. The rear lower section of the rear wheel only would be visible in position 10</p>
Front projection mirror		<p>(8), (9), (10)</p> <p>The front wheel only would be visible in position 8. The lower section of the cyclist only would be visible in positions 9 and 10</p>

Component	Image	Cyclist position visible [(x) denotes that a proportion of cyclist is visible]
Windscreen		(9), (10), 11, 12, 13, 14 The upper torso only of the cyclist was visible in position 10. The head and right arm only were visible in position 9
Nearside side window		(7) The upper part of the head only of the cyclist was visible in position 7

The 1.5m tall cyclist is partially visible through the nearside side window from this particular driver's eye point in position 7 (Figure 41). However, whilst the proportion of the cyclist that is available to be seen in this view is only small (approximately the top half of the head) it is more than would be visible from the DAF Mixer (top of head) and definitely more than the DAF Tipper where the cyclist is not directly visible in this position.

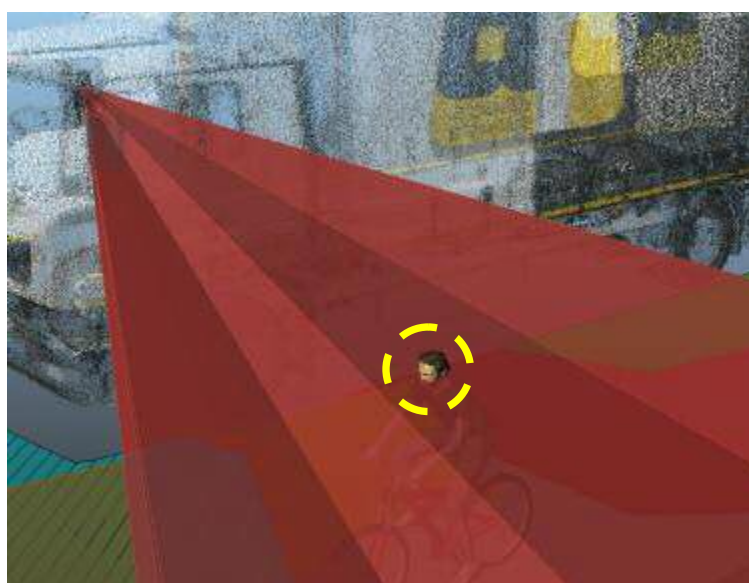

Figure 41: The cyclist in position 7 showing that for the MAN Curtain side lorry the upper half of the head only is visible of a cyclist 1.5m tall

5.5.4 Comparison of cyclist position assessment

The visibility of the 1.5m tall cyclist in the various positions on the nearside of the vehicles was discussed in the previous sections. Table 28 shows the results of the different position assessments collated into a single table.

From these collated data it is possible to see that there is a pattern in that between positions 5-12, none of the vehicles would provide the driver with a complete view of the 1.5m tall cyclist.

This is not unexpected following the assessments performed earlier, due to the fact that these positions lie within the regions where the ground is not always visible to the driver. The proportion of the cyclist that is visible in each of these positions varies with each vehicle and is described in the tables above. For all of the vehicles tested, it was found that it was not possible to fully see the cyclist in three of the positions used, these being 7, 9 and 10 – the combination of the partial direct and indirect views would also not allow the 'full' cyclist to be seen. This is believed to be a function of the shape and angle of the three dimensional mirror zones from the close proximity and front projection mirrors and the visible rake angle from the windscreen.

When the cyclist was in position 7 only a small proportion was visible in any of the vehicles. For the DAF Mixer and the MAN Curtain side the upper half of the cyclists head was visible in the lower part of the nearside side window. However, for the DAF Tipper, partly due to its height, the cyclist was not visible in the nearside side window, although it had a larger ground coverage area for the close proximity mirror and thus the lower part of the cyclist was visible towards the edge of this mirror.

Whilst position 7 was approximately 3m away from the nearside of the vehicle, if the lorry was to make a lane change or manoeuvre into lane one or turn left it is possible that it would encounter the bicycle with only limited time for the lorry driver to see the cyclist, perceive it as a hazard and then react. Therefore, improving the visibility to the nearside would potentially increase the opportunity the driver would have to identify a hazard and react.

It has been stated throughout the visibility assessments that whilst the visibility zones have been identified and mapped they are only appropriate when the driver actually looks in the appropriate direction or into the appropriate mirror. The assessment has been performed with the vehicles in static positions; therefore any speed differential between the cyclist and the vehicle will alter the position of the cyclist in the visibility zones and will affect how the driver is able to see the cyclist. In addition, the length of time for which the driver glances at the particular mirror or through the particular window will affect how easily the driver is able to identify a cyclist.

A quick glance may result in the driver 'missing' the cyclist even if they are within the visible zone.

Table 28: The collated results of the assessment of the cyclists that would be visible (wholly or a proportion thereof) for each viewing component of the three assessed lorries. The cyclist was 1.5m tall in this assessment

Component	Vehicle	Cyclist position (as per Figure 37)													
		• denotes wholly visible, (•) denotes partially visible													
		1	2	3	4	5	6	7	8	9	10	11	12	13	14
Plain rear view mirror	Mixer		•		•		(•)								
	Tipper		•		•		(•)								
	Curtain		•		•		(•)								
Wide angle rear view mirror	Mixer	•	•	•	•	•	(•)	(•)							
	Tipper	•	•	•	•	(•)	•								
	Curtain	•	•	•	•	(•)	•								
Side close proximity mirror	Mixer								(•)		(•)				
	Tipper						(•)	(•)	•	(•)					
	Curtain								(•)	(•)					
Front projection mirror	Mixer										(•)		(•)		(•)
	Tipper								(•)	(•)	(•)				
	Curtain								(•)	(•)	(•)				
Windscreen	Mixer									(•)	(•)	(•)	(•)	•	•
	Tipper									(•)		(•)	(•)	•	•
	Curtain									(•)	(•)	•	•	•	•
Nearside side window	Mixer							(•)							
	Tipper														
	Curtain							(•)							
Rear cab window	Mixer	•		(•)	(•)		(•)								
	Tipper														
	Curtain														

6 Driver behaviour

Driver error is the most common cause of road collisions (e.g. RoSPA, 2011). The range of driver errors (and driver limitations) that can contribute to collisions is of course extensive, and will depend on the driving environment under investigation. This study observed driver behaviour with a view to analysing the different errors that drivers of construction vehicles could make, and which might lead to a collision with a cyclist. Factors which may affect the likelihood of these errors were also considered.

6.1 Method

Three observational drives were conducted, in which a TRL researcher accompanied drivers on journeys through Central London. Each of the drives took place in a different vehicle, two of which were construction vehicles and one of which was a goods delivery vehicle:

1. Four-axle tipper
2. Four-axle cement mixer
3. Three-axle curtain sider.

Before the journey began the driver was presented with an information sheet about the study and given an opportunity to ask questions about it, before signing a consent form. The researcher sat silently in the passenger seat of the vehicle and observed the driver's action sequences to control the vehicle and interactions with other road users. The focus was on approaches to junctions and roundabouts, although a general assessment of driving style, speed and headway choice, workload and engagement with distractions was also made. A modified version of the Viennese Driving Test (Risser & Brandstätter, 1985) was used to record how drivers carried out manoeuvres at junctions and roundabouts, including aspects such as mirror and indicator use, lane position and lane keeping. Short interviews were conducted with the drivers at the end of the drive in order to review key events and access their opinions of why collisions occur between cyclists and construction vehicles.

The data gathered were used to carry out an analysis of driver tasks while turning left at a junction or exiting a roundabout. A task analysis (Pew, Miller & Feehrer, 1987) is a detailed, step-by-step description of action sequences, decisions and judgements, and in this study it was extended to enable identification of sensory modalities which are over and under-used, potential driver errors (for each of the 81 low-level driver tasks) and performance shaping factors (i.e. factors relating to the driver, cyclist, vehicle, environment or organisation which may affect the likelihood of error). The analysis of human errors was carried out using Swain and Gutman's (1983) *External Error Modes*, and performance shaping factors were identified by drawing on *Systematic Human Error Reduction and Prediction Approach* (SHEPRA; Embrey, 1986), driver opinions as expressed during the post-drive interviews, and the assessment of the researcher who carried out the observational drives.

Full case studies are included in Appendix A.

6.2 Cognitive task analysis

6.2.1 Description of the task

At a very simplistic level a left turn is a sequence of tasks as follows:

- Perceive junction
- Check mirrors
- Indicate
- Adjust speed
- Manoeuvre vehicle through the junction.

Although the task can be thought of as sequential, the observations clearly highlighted that there is a cyclic nature to some key tasks carried out by the drivers. Drivers were not making decisions having checked their mirrors at one point in time; rather, each time they checked their mirrors they were updating their mental representation of the real world, including the location of key hazards in relation to the vehicle. Indeed, if a previously present hazard could not be seen, mirror checking increased, and this gave further support to the notion of a cyclic task.

Hollnagel's contextual control model (2005) looks at human information processing tasks as cycles rather than linear sequences. Figure 42 shows that as people take in feedback from external events, this modifies their understanding of the environment, which then directs their actions, which provides further feedback, and the cycle goes on.

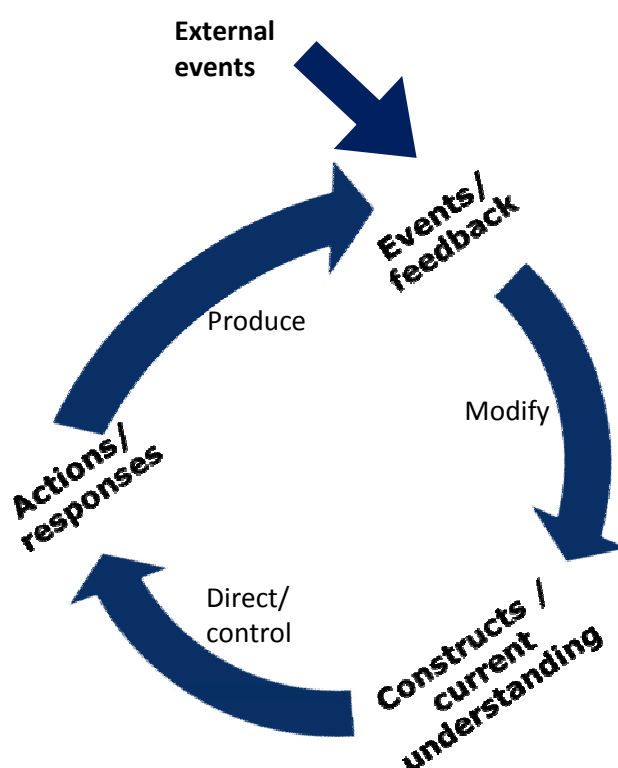

Figure 42: Hollnagel's basic cyclical model of human action (from Hollnagel 2005)

6.2.1.1 Analysis

The cyclical model is very useful in analysing the tasks carried out by drivers during the execution of a left turn. As the sub-tasks for a left turn are carried out, drivers draw on their mental model of their surroundings in order to make decisions, and as a result of feedback, they update this mental model.

The cognitive task analysis identified a total of 81 task steps (see Appendix B) for drivers executing a left turn, and these were grouped under seven high level tasks. Two of these were very strongly cyclic tasks that are performed continuously while driving and during manoeuvres:

- Control speed
- Maintain awareness of driving situation (including mirror checks).

The remaining tasks can be thought of as a sequence, even though there are feedback and control elements to them:

- Approach junction
- Respond to hazards to the left of the vehicle
- Indicate left
- Move to right side of lane
- Turn left.

The analysis shows that there are a series of manual tasks which are likely to be performed without the need for much attention (such as steering and use of pedals). Most of the tasks are, however, visual and cognitive tasks, with the visual system being in particular demand when maintaining an awareness of hazards around the vehicle.

6.2.2 Human errors

A range of human errors are theoretically possible during each of the 81 tasks analysed; however, some of them appear unlikely (e.g. failure to locate indicators). After careful consideration of the cognitive task analysis, those that stand out as being more likely given the task and the limits of human cognitive processing in the areas considered are listed in Table 29.

Table 29: Driver errors that could lead to a collision between a HGV and cyclist

Human Error	Example	Consequence
Failure to control vehicle speed	Junction taken at 30mph instead of 10mph	Vehicle control difficult and driver may not have enough time to correctly monitor for hazards
Failure to look for hazards	Mirror not checked	Driver not fully aware of hazards and may therefore have a collision
Check for hazards carried out too late	Mirrors checked at junction	Driver misses cyclist alongside the vehicle, who was visible in the mirrors on the junction approach
Failure to perceive cyclist	Cyclist not visible in mirrors or was difficult to detect	Driver not aware of cyclist and may have a collision
Cyclist perceived too late	Cyclist seen but it's too late to avoid a collision	Collision occurs
Failure to judge significance of perceived element	Cyclist seen behind the vehicle, but no consideration that the cyclist would catch up and be alongside the vehicle as it slows down for the junction	Driver does not consider the cyclist to be a hazard and may have a collision
Junction perceived too late	Driver sees the junction late and decides to take the turn anyway	Driver responds quickly without careful consideration of consequences. May have a collision
Failure to assess junction layout	Junction narrow for vehicle but this isn't considered at all by the driver	When the turn becomes difficult the driver puts himself under pressure to complete it, and may have a collision
Junction layout assessed incorrectly	The driver assesses the junction to be wide enough for a comfortable turn but in fact it is quite narrow	As above
Vehicle aligned incorrectly for junction geometry	Driver makes a sharp turn keeping to the left, rather than pulling right first	As above
Incorrect route taken through junction	Driver encroaches on other lanes or mounts the kerb during the turn	Driver may collide with other road users in adjacent lanes or on kerb
Failure to activate indicator	Driver does not indicate	Other road users don't know that the vehicle is turning and may behave inappropriately
Indicator activated too late	Driver indicates, but not until at the junction	Other road users don't know that the vehicle is turning and may behave inappropriately

A large proportion of the entries in Table 29 relate to visual monitoring tasks. Drivers are required to monitor the scene ahead as well as using a number of mirrors (and a CCTV system, if present). Human vision is a directional resource, operating within a field of 120 degrees of arc, with only the central region of this range allowing detection of detail. Thus, vision is a constrained resource during driving and it is important to consider that

it is not possible to fixate on a mirror and the road ahead, or two mirrors, or even different parts of the road scene at the same time; rather it is necessary to divide attention between these locations while maintaining an awareness of the environment (e.g. Wickens, 1992). Theeuwes (1996) found that visual attention was guided by a number of factors including expectancy; thus it is important to recognise that drivers' past experiences are likely to affect where they look and what they look for. Therefore, there is an inherent imperfection in this system which could lead to errors when drivers change from one setting to another (for example a different vehicle type); this should also be considered in any training that is carried out on different vehicles and types of journey.

The analysis of potential errors shows that there is unlikely to be one single cause of vehicle collisions with cyclists during turning manoeuvres, and in fact, that some of the errors leading to a collision may take place before the driver and cyclist arrive at the junction.

6.2.3 Factors that affect the likelihood of error

This section draws upon interviews with drivers, the observations carried out during the drives, and databases of psychological error mechanisms and contributory factors identified by officers attending crashes between large vehicles and cyclists, during a left turn manoeuvre. Key mechanisms which could increase the likelihood of potential errors leading to crashes between cyclists and construction vehicles are shown in Table 30.

Table 30: Factors which may affect the likelihood of human errors leading to HGV-cyclist crashes

Vehicle factors	Environmental factors	Driver factors	Cyclist factors	Organisational factors	
Vehicle shape and height reduces visibility	Distractions outside vehicle	Lack of concentration	Not following a defined path, conforming to rules or expectations (position within lane, under- or overtaking, going around the outside or inside of roundabouts)	Hire and reward systems encourage faster driving or risk taking	
Large turning circle makes turning manoeuvres challenging in constrained spaces	Behaviour of other road users (e.g. causing vehicle to swerve)	Looking somewhere else (this could be part of the driving task, e.g. another hazard)	Attempting to undertake, or pull alongside, a vehicle that is turning left	Time pressure	
Poor view from mirrors	Tight corners	Stress	Misinterpreting vehicle manoeuvre	Shift patterns	
Objects lost from view during turning manoeuvre	Narrow roads	Distraction (e.g. using unsuitable navigation tools)	A lack of awareness of the limitations of HGV mirrors	Expecting the driver to supply own navigation tools	
Width of vehicle makes it difficult to pass other road users	Weather (e.g. difficult to see cyclists in the dark)	Layout of roundabouts (difficult to see objects in mirrors around curves)	Poor spatial orientation (e.g. misjudging distance to cyclist)	Catching up with the vehicle (and undertaking it) as it slows down for the corner	Insufficient or ineffective training for drivers and cyclists
		Short cut taken (e.g. mirrors not properly adjusted, swerving without checking mirrors)	Not staying behind the vehicle when turn indicators (or audible warnings) are activated	Insufficient emphasis of safety	
		Stereotype (e.g. habits from driving a car take over)	Motivation to keep moving as quickly as possible		
		Assumption (e.g. low expectation of a cyclist)			
		Fatigue or other impairment (e.g. alcohol)			
Speeding					

It can be seen that a very broad range of factors can affect driver errors. These are broadly grouped as:

- **Vehicle factors**, which primarily relate to size in relation to road infrastructure, lack of visibility and blind spots
- **Environmental factors**, which relate to the design of the road environment, behaviour of other road users, weather and distractions external to the vehicle
- **Driver factors**, which include factors affecting driver attention, judgements and task sequence errors
- **Cyclist factors**, which primarily relate to their conformity to driver expectations and their awareness of and responses to large vehicles
- **Organisational factors**, which include training, culture and a range of factors which encourage or discourage risk taking.

It is clear that some of these factors are interlinked. For example, the time pressure potentially put on drivers by their employers may be linked to driver stress or taking shortcuts, which are driver factors.

6.3 Comments and conclusions

This strand of the research aimed to understand the cognitive processes involved in driving a construction vehicle, and to identify some of the factors that would make the task easier or more difficult. Although the sample of drivers observed was small, the data gathered was sufficient to carry out the required analysis at this level.

It is likely that companies with poor practices in terms of road safety would not have put forward their vehicles and drivers for the research. Thus, it is also possible that the journeys, driving styles and behaviours observed are somewhat better than average. Indeed, during one of the drives the driver of a different tipper truck was observed swerving around turning vehicles and generally driving in a much more aggressive manner.

A range of factors may affect the likelihood of an incident between a construction vehicle and cyclist, through increasing the likelihood of potential errors identified in the cognitive task analysis. In addition to the self-evident importance of exposure of cyclists to construction vehicles, these include vehicle factors, the road layout, driver behaviour, cyclist behaviour and organisational factors. These factors are unlikely to be present within each organisation, driver, cyclist, vehicle or road environment, but where they are present, there are likely to be safety benefits from addressing them successfully.

Overall, there did appear to be some differences between the way the delivery vehicle and the construction vehicles were driven. The construction vehicle drivers used route knowledge or paper maps to navigate, whilst the delivery driver used a satellite navigation system, which was not designed for use in trucks. In addition, where possible, the driver of this vehicle tended to use the right hand lane. Finally, the drive in the delivery vehicle took place when there was no delivery target to meet, and this may have led to a very relaxed approach to the drive, although the drivers of the construction vehicles did not show signs of being under time pressure despite their vehicle being loaded with construction materials. It is not possible to generalise from the small number of observations, but these differences merit further investigation.

Other factors worth investigating include whether different types of vehicle undertake significantly different types of journey, thus affecting their exposure to cyclists and certain types of manoeuvre.

7 Construction site interviews

7.1 Method

Interviews were carried out with individuals from the different levels of networks involved in a construction site. These interviews were intended to improve understanding of how the various individuals and organisations in a given network perceive the issues associated with vulnerable road user safety, as well as investigating contractual practices, recruitment, remuneration etc. TRL researchers visited three sites to conduct interviews, and these are described in detail below. In addition to carrying out interviews on construction sites, interviews with general hauliers were conducted in order to draw comparisons between the two industry types (see section 6.2.5).

In addition to the interviews carried out with members of construction site networks and general hauliers, a number of individuals involved in the aggregates industry and highways and streetworks were interviewed, as well as a cement tipper driver. These were all from large national companies (with the exception of interviewee 3 whose organisation is based mainly in the South East). Some of the organisations represented by these interviewees provided aggregates services to the construction sites visited. Two of the interviewees (interviewees 3 and 4) had previously worked in the general haulage industry, and so were able to provide additional insight into any differences between the two sectors. The construction interviewees were:

- General interviewee 1: Health and safety manager, aggregates and concrete products
- General interviewee 2: Transport director, aggregates
- General interviewee 3: Transport manager, aggregates
- General interviewee 4: Transport manager, aggregates
- General interviewee 5: Construction site manager, highways and streetworks
- General interviewee 6: Driver, aggregates

Interviewees were provided with £15 for taking part. The conversations were recorded with permission. A copy of the interview guide is included in Appendix B. Interview transcriptions were analysed using a form of thematic content analysis, which enabled the researchers to extract general themes from the range of responses given. These themes are reflected in the subheadings below. Where possible, information provided by members in different levels of a chain (e.g. client – principal contractor – subcontractor) was compared.

7.2 Findings

7.2.1 *The general structure of construction site networks*

Construction sites can vary in a number of ways, including:

- Length of project
- Budget
- Number of workers

- Site accessibility
- Client type (private, commercial, Government etc.)
- Need for demolition prior to construction

A generic network structure is shown in Figure 43. In addition there will be organisations delivering or removing goods without actually carrying out work on the construction site.

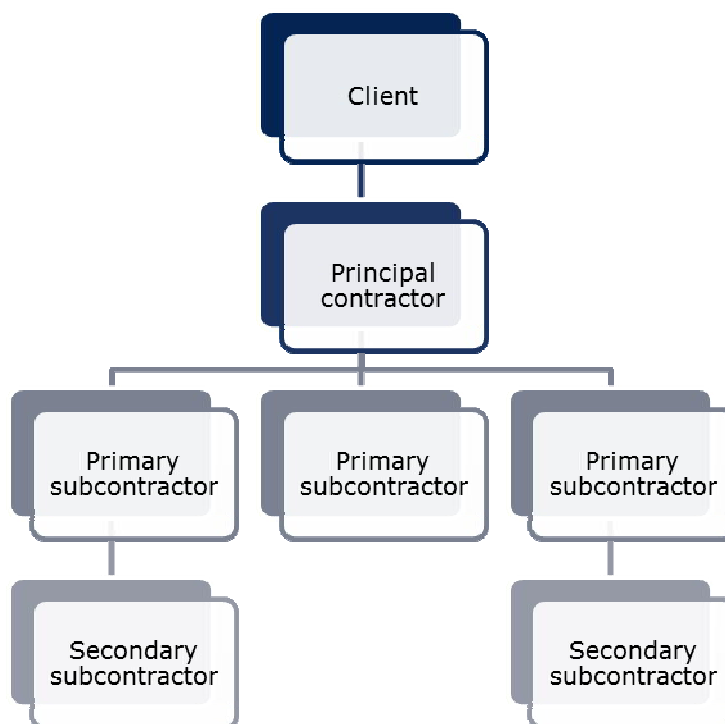

Figure 43. General construction site network structure

The principal contractor will generally employ a project director whose responsibilities include:

- Representing the client on site
- Ensuring projects are delivered on time and to budget
- Monitoring, managing, controlling and reporting on spending
- Ensuring that projects are run in accordance with H&S legislation and requirements
- Subcontracting various elements of the construction works
- Negotiating with subcontractors for materials and services
- Monitoring and co-ordinating the activity of subcontractors

One of the subcontractors will often be a logistics manager/provider. The responsibilities of a logistics manager include:

- Acting as the principal logistics point of contact for the project manager
- Ensuring compliance with legal and contractual logistics requirements
- Auditing the contractor, subcontractors and suppliers against legal and contractual requirements

- Planning and managing equipment, plant, materials and people movement requirements, and developing logistics plans.

At larger construction sites, there may also be a traffic manager at the principal contractor or subcontractor level. This individual would carry out a similar role to a logistics manager, with a specific focus on transport issues.

Subcontractors will deliver particular work packages, in co-operation with the principal contractor and other subcontractors. On a standard construction site, subcontractors will include:

- Electrics/lighting
- Drylining
- Flooring
- Windows
- Roofing
- Ventilation
- Muckaway/waste disposal

There will also be suppliers involved who are responsible for the provision of goods and/or services, such as furniture, IT equipment, and so on.

Construction vehicles may be operated by organisations at all levels of the network from principal contractor downwards. Subcontractors (particularly further down the chain) may be owner-drivers who do not report to any health and safety manager (other than themselves). These will usually operate smaller vehicles but on occasion will operate a construction vehicle.

7.2.2 Construction Site 1

7.2.2.1 Interviewees

Site 1 was an office building development in a large town within a south London borough. The client was a local authority and the project duration is three years. At the time of the visit, the project was less than a year from completion. TRL researchers visited the site in July 2012 and carried out seven interviews with available and relevant members of the construction network:

- Client: Two Environmental Consultants (local authority)
- Principal Contractor: Project manager
- Primary Subcontractor 1: Project manager (mechanics and engineering)
- Primary Subcontractor 2: Project manager (drylining and screening)
- Primary Subcontractor 3: Logistics site manager (logistics management company)
- Secondary Subcontractor 1: Driver (skip hire company)
- Secondary Subcontractor 2: Driver (construction hire company)

The interviewees and their position in the network are shown in Figure 44.

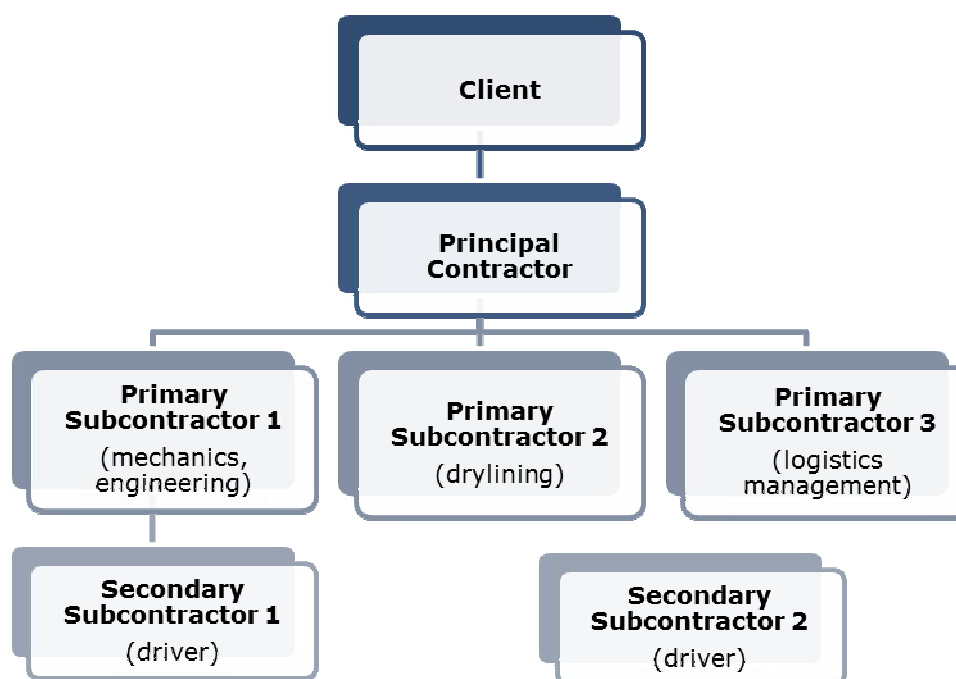

Figure 44. Construction Site 1 interviewee network structure

7.2.2.2 Management of driver safety

A key finding from Site 1 was that the safety of construction vehicle drivers travelling to and from the construction site was not perceived to fall under the Client's or Principal Contractor's remit of responsibility until the driver enters the construction site.

"We've stopped drivers from coming to site where we've felt they've not been appropriate for this site. But that doesn't stop them from driving around and doing something else on the road, so I don't know how I would do that."
(Principal Contractor)

Interviewer: *"So just to clarify, there's nothing contractually with any of your subcontractors about how they drive on the road, it's just on the sites?"*

Respondent: *"No, I don't think I've got anything in them [the contracts]...he's got to be trained, he's got to have the licence, and he's got to observe the laws of the land...who polices him from doing that? That's what the police do, the traffic police, I guess. It's not for us, is it?"* (Principal Contractor)

This is corroborated at the primary and secondary subcontractor levels of the network. If a driver was involved in an incident while driving to or from the site, it was stated that it would be reported and dealt with within their own organisation, but would not be reported up the chain.

Interviewer: *"If they [subcontracted drivers] had any near misses or incidents on the road on the way to or from the site...would they report them?"*

Respondent: *"I don't think they would...that's the ethos that is driven into everyone. It's kind of what goes on outside of the hoarding, it doesn't matter."*
(Primary Subcontractor 1)

Interviewer: *"When they [your subcontractors] leave the site, do you see any responsibility then for their driving safety?"*

Respondent: *"No."* (Primary Subcontractor 2)

"As far as when they leave the gates, once the driver has actually exited and is out, effectively out of our site they are then no longer our responsibility" (Primary Subcontractor 3)

Interviewer: *"[If you were involved in an incident] would you know if your office would inform whoever you were working for at the time?"*

Respondent: *"No. Once it's on my lorry, really...it's down to us. If it was on a site then obviously I'd have to stop and take pictures and what not."* (Secondary Subcontractor 1)

It was reported that off-site road collisions do not always form part of a subcontractor's safety statistics:

"We had a guy on a motorbike coming down the corner of the job six or eight weeks ago now and he was hit by a [subcontracted] van...it doesn't get into our safety statistics because it's happened outside of the job [site], so it doesn't get monitored or controlled in any way like that and perhaps it should. If it's work-related travel, then maybe it should be picked up on the statistics." (Primary Subcontractor 1)

Although this incident did not involve a construction vehicle, the reporting procedure would in all likelihood be similar regardless of the vehicle type.

Likewise, an incident off-site may not be noted in the safety statistics of the driver's employer:

"Their organisation would deal with it but, again, it wouldn't form part of their health and safety stats that goes to HSE because it didn't happen at work. And that's the problem; a lot of incidents that happen outside of work [sites] don't get reported." (Primary Subcontractor 1)

Under-reporting may result in an organisation misjudging the importance of the driver safety issue. Often a focus on driver safety is reactive rather than proactive, and so it is important that collisions and near misses are reported and recorded.

Drivers will often need an incentive to do this, particularly if they feel that reporting any incidents involves filling in paperwork and may result in a requirement for them to undergo additional training or assessments. Incentives are provided in some instances (although this description refers to on-site rather than off-site reporting):

"We do a monthly £25 voucher...and also we encourage breakfast vouchers for people if they...you see them constantly either reporting near-misses or carrying out their work really safe, we will give them a breakfast voucher." (Primary Subcontractor 1)

Under-reporting may be a particular problem where owner-drivers are employed, as they are not always subject to the same rigorous health and safety policies and procedures as drivers employed by larger organisations.

In contrast, it was felt that the behaviour of drivers employed directly is more controllable:

"We're in control of pretty much all our own delivery drivers. We know what they're expected to do and not do, and they generally abide by the rules. But for everyone else it's quite difficult for us to enforce." (Principal Contractor)

7.2.2.3 Selection

Site 1 is subject to a construction logistics plan (CLP) as provided by the local authority, who is also the client for the construction project. This forms part of the selection process, and requires subcontractors at all levels to have bronze FORS (Fleet Operator Recognition Scheme) accreditation, which covers drivers and driver management, vehicle maintenance, fleet management, transport operations and performance management. However, once accreditation has been achieved, organisations do not necessarily act to ensure that standards are maintained.

Respondent: *"There was a requirement on this job for, was it FORS, the Freight Operator Recognition Scheme? All of our suppliers had to sign up to that...if it's a requirement of the main contractor, we will piggyback on the back of that...and they then have to register."*

Interviewer: *"Are you a member of FORS?"*

Respondent: *"We've registered but, again, we don't do anything as such other than manage the processes to deliver the project, but our subcontractors and suppliers to"* (Primary Subcontractor 1)

Others did not mention FORS when selecting subcontractors:

Interviewer: *"How do you select subcontractors?"*

Respondent: *"We have a pre-qualification document that covers all aspects of the business from health and safety to the financial aspects...we then review it and then we actually check each of the companies to look at it in more detail and to see are they actually telling us the truth."* (Primary Subcontractor 1)

The client stated that, whilst FORS bronze registration is listed as a requirement for all contractors, there is not the time or resource for the client to monitor this, and so they put their trust in the Principal Contractor:

"Main contractors will be expected to demonstrate that their suppliers are committed to safer and more efficient operating by requiring them to register for membership with TfL's FORS...and attain bronze membership as a minimum...we haven't got the time to sort of monitor that as such, we would expect the site manager there to...but I mean I suppose we could ask [the site manager] to provide us with proof." (Client)

For Site 1 respondents there were no selection criteria in place for themselves or for their subcontractors relating to driving off-site. The key concern was that driving licences were checked.

"[The subcontractors] have got their own drivers and their own driving and transport division and occasionally our company will go and inspect...you know, they check licences. They also check that they're competent, really...the thing is we can insist on standards coming here but...we take ownership from once they get through the gate." (Primary Subcontractor 2)

"Any points or anything, they then check it all out. You've got to let them know." (Secondary Subcontractor 2)

7.2.2.4 Contracts and payments

Some contractual arrangements are very simple, for example between Primary Subcontractor 3 (logistics provider) and the Principal Contractor:

Respondent: *"We are employed directly through a standard subcontractual basis to [Principal Contractor] as indeed any other subcontractor would be."*

Interviewer: *"And do you have any subcontractors at all?"*

Respondent: *"No...occasionally we get asked to do something and then we might get a subcontractor in...but not as a rule...we don't actually employ anyone on this site to drive."* (Primary Subcontractor 3)

Other primary subcontractors will have a number of secondary subcontractors under them, for example:

"I mean [Primary subcontractor 1] have probably got, maybe eight sub-subcontractors on site...so you'll have seven first tier contractors then, out of those, except us, they would employ maybe two subcontractors...or maybe more...all the contractors or subcontractors tend to be reasonably sized...on other occasions they might use a company that only has a handful of people." (Primary Subcontractor 3)

According to the Principal Contractor, they do not operate any pay-per-load contracts, but subcontractors might do so:

"We don't, all our work and stuff's contracted out and it's the subcontractor who manages it...we don't really get involved in that sort of thing." (Principal Contractor)

In general, drivers of construction vehicles are salaried rather than being paid per load (although their employer may be paid per load):

"[I'm employed] on a salary...it's the same for all of them [drivers]." (Secondary Subcontractor 2)

"It's all, not per load; we just get a basic [wage]." (Secondary Subcontractor 1)

7.2.2.5 Communication and reporting

Communication of driver safety messages and requirements is seen as a key aspect of ensuring that drivers are safe on the road. The project manager at Site 1 indicated that there is room for improvement in communicating safety messages, particularly in terms of understanding who to give the messages to:

"I'm not involved in the outside world...no one tells me what's going on in London in terms of freight...I struggle with websites...surely the approach is to go and contact a senior in each organisation and get a contact through them and start feeding through on that...then at least they know who to actually send it to...because I haven't got any information to give them [subcontractors], what do I try and instil in these people apart from your drivers should be driving properly?" (Principal Contractor)

It was also suggested that, despite a general improvement in safety culture on construction sites in recent years, there is not enough awareness that incidents involving construction vehicles on the road are currently a cause for concern.

It was felt that raising awareness may be an important step:

"The industry doesn't know that these accidents are occurring...the industry is not going to do much about it until they're told...how do you get everybody else to [improve their safety] unless you're telling them that these things are going on, and unless people start getting prosecuted?" (Principal Contractor)

There was also a lack of awareness about which laws are applicable to construction vehicle drivers travelling to or from a site:

Respondent: *"What would you prosecute them under, the Road Traffic Act I guess rather than the Health and Safety at Work Act."*

Interviewer: *"Health and Safety at Work Act is applicable."*

Respondent: *"Yes, but how do you get...when you're out there no one's in control of the environment that the guy's driving in...it must be quite hard to prosecute."* (Principal Contractor)

Near misses (i.e. events which did not result in injury or damage, but had the potential to do so) are not reported on the whole:

Interviewer: *"If you had a near miss off site, would you report that?"*

Respondent: *"It depends...a near miss is a near miss, isn't it...if everyone's okay and we've both walked away and it's a near miss, I suppose then, yes, I'd probably just get back on and keep that one to myself, if I'm being honest."* (Secondary Subcontractor 1)

Interviewer: *"If there's any near misses off site, do you report them?"*

Respondent: *"Not really."* (Secondary Subcontractor 2)

7.2.2.6 Driver pressure

Site 1 operated an online vehicle booking system (as part of the requirement of the CLP), whereby any vehicle entering the construction site is booked in at least 48 hours in advance. Drivers are provided with an arrival time slot, and vehicles arriving outside of the allotted time may be turned away. Figure 45 is a summary of deliveries, as well as environmental and health and safety statistics for Site 1.

Allocated time slots explicitly place pressure on the driver to arrive at the construction site on time:

"Yes, they do [feel pressured to arrive on time], there's no question about that...if you don't get there on time your delivery just does not get in, it gets sent away...so companies are under a lot of pressure to manage their deliveries, to get them to sites when they need it." (Primary Subcontractor 3)

Interviewer: *"Is there much pressure to get to site?"*

Respondent: *"Yes, there's a lot of pressure. That's the one thing about this job, it's very stressful...so I can see why accidents happen sometimes."* (Secondary Subcontractor 1)

However some subcontractors reported that they avoid placing pressure on their drivers:

Respondent: *"If they can't make it...they'll turn up and try and get in, then will be told that they can't or they can slip them in. If not...they return back and then we run the cost of that wasted journey."*

Interviewer: *"So do you think they're under pressure to get there so that you haven't got that cost?"*

Respondent: *"No, no pressure from us to do that."* (Primary Subcontractor 2)

Project Information Summary

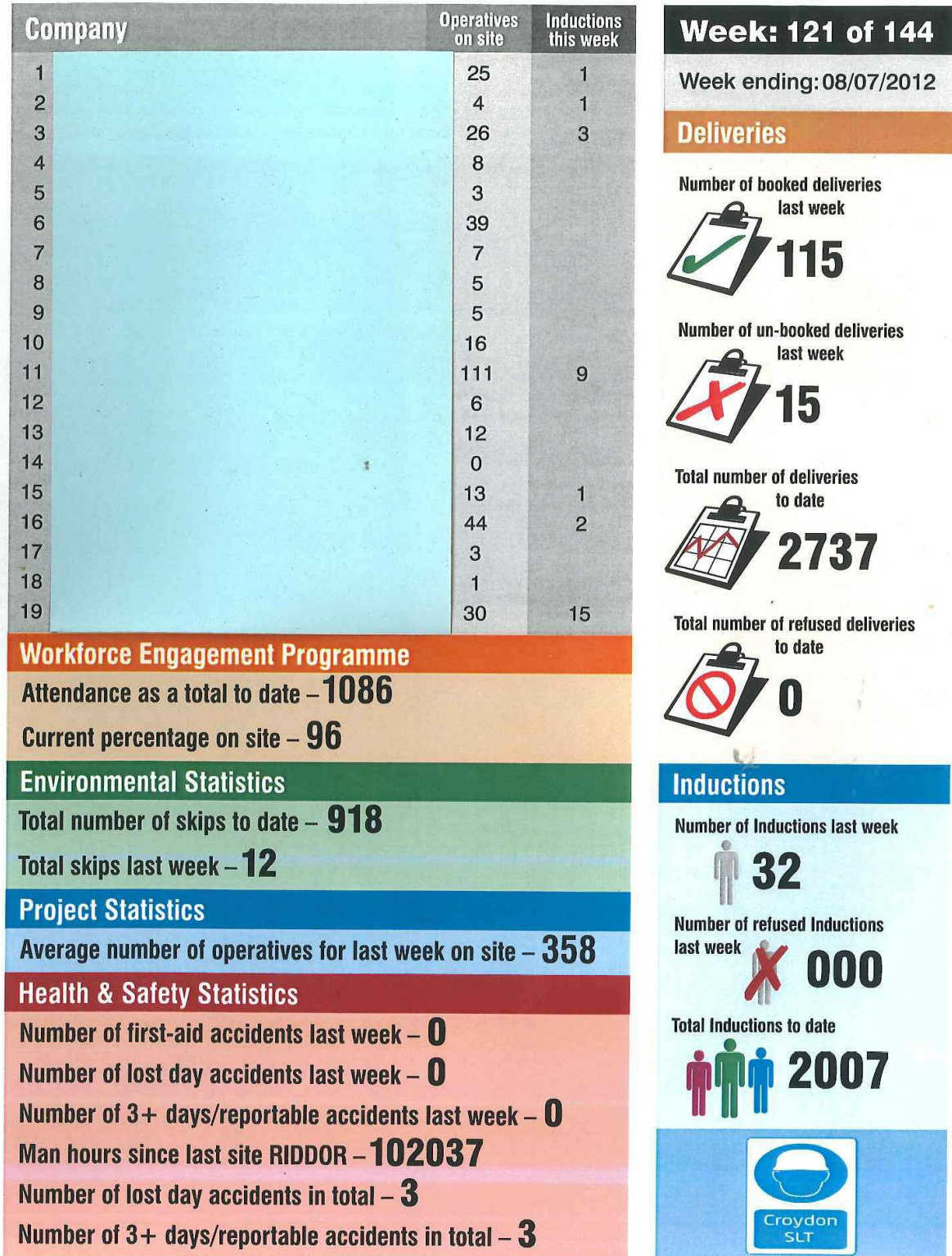

Figure 45. Weekly summary of Site 1 deliveries etc.

7.2.3 Construction Site 2

7.2.3.1 Interviewees

Site 2 was a new residential development in a north London borough. The client was a private company and the project duration is three years. At the time of the visit, construction had been underway for four weeks. TRL researchers visited the site in July 2012 and carried out two interviews face-to-face and a further three by phone:

- Principal Contractor: Construction manager (housing development organisation)
- Primary Subcontractor: Site manager (groundworks)
- Secondary Subcontractor: Transport manager (groundworks)
- Tertiary Subcontractor: Manager and driver (waste disposal)
- Quaternary Subcontractor: Transport manager (waste disposal/aggregates)

The client was a private joint venture made up of the housing development organisation and a London housing association. A separate interview with the client was not conducted, but an interview with a representative of one half of the joint venture (i.e. the construction manager) was carried out.

The interviewees and their positions in the network are shown in Figure 46.

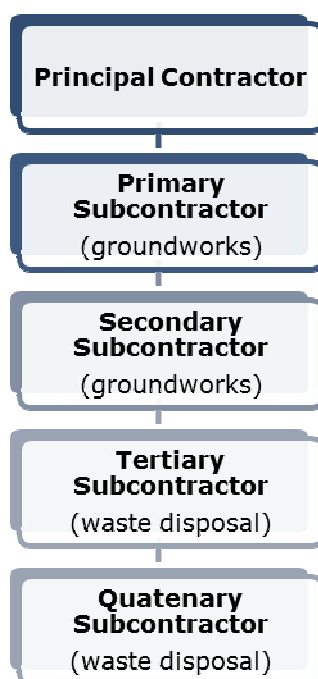

Figure 46. Construction Site 2 interviewee network structure

7.2.3.2 Selection

The site manager described the procurement process for subcontractors. The procedure is overseen by a commercial team, who develop a package for different aspects of the construction project (e.g. groundworks). This package will describe what is required, and is sent out to a tender list. In order to be included on the tender list, a subcontractor must be approved and demonstrate that they meet certain safety criteria. Once quotes

are received, the three best quotes are considered, the chosen tenderer is invited to a pre-contract meeting, and the contract is then awarded for placement.

In terms of safety requirements, Construction Health and Safety Excellence (CHASE) is mandatory, as well as other aspects of health and safety, but with the notable exception of off-site road safety:

Respondent: *"They have to demonstrate to us, you know, it's not just on site safety, it's across the board, Health & Safety policy statements, public liability assurance, other assurances, you know, how do they monitor safety, have they got any other safety issues externally, all of those sort of criterion."*

Interviewer: *"And is there anything relating to road safety?"*

Respondent: *"Good question. Probably not."* (Principal Contractor)

Whilst collision statistics are considered when choosing subcontractors, the respondent indicated that statistics relating to road safety would *not* form part of this selection process.

Figure 47 is a safety questionnaire for subcontractors, demonstrating the areas considered by the Principal Contractor. Note the absence of questions regarding road safety.

Occupational Safety, Health & Environmental System Safety Questionnaire for Non Accredited Sub-Contractors	SHE Form 57 Page 1 of 1 Issue date: September 2011
---	---

IN ORDER TO EVALUATE YOUR COMPETENCY RELATING TO HEALTH & SAFETY PLEASE COMPLETE AND RETURN THIS QUESTIONNAIRE

FOR WHICH CONTRACT IS THIS FORM BEING COMPLETED?

SUPPLIER/SUB-CONTRACTOR

GROUP Ref:

NATURE OF BUSINESS:

ADDRESS:

1	Do you have a company Safety Policy (not a legal requirement if less than 5 employed in your business) Tick as appropriate: Signed Safety Policy Attached <input type="checkbox"/> No Policy available <input type="checkbox"/>																																																
2	Does your company receive safety advice? How is this provided? Tick as appropriate: Externally Provided (Consultant) <input type="checkbox"/> In-House Trained (E.g. NEBOSH) <input type="checkbox"/> None Provided <input type="checkbox"/>																																																
3	Do you employ sub-contractors? (including labour only) YES <input type="checkbox"/> NO <input type="checkbox"/> 3.1 If Yes how do you evaluate their health & safety competency																																																
4	Do you provide any of the following safety training: Delete as appropriate																																																
	<table style="width:100%; border-collapse: collapse;"> <tr> <td style="width:50%;"></td> <td style="width:25%; text-align: center;">Employees</td> <td style="width:25%; text-align: center;">Sub-contractors</td> </tr> <tr> <td>Induction Training</td> <td style="text-align: center;">YES/NO</td> <td style="text-align: center;">YES/NO/N/A</td> </tr> <tr> <td>Supervisor Management</td> <td style="text-align: center;">YES/NO</td> <td style="text-align: center;">YES/NO/N/A</td> </tr> <tr> <td>Safe System of Work (i.e. Risk Assessments etc.)</td> <td style="text-align: center;">YES/NO</td> <td style="text-align: center;">YES/NO/N/A</td> </tr> <tr> <td>CSCS or Accredited Scheme</td> <td style="text-align: center;">YES/NO</td> <td style="text-align: center;">YES/NO/N/A</td> </tr> <tr> <td>Percentage of all employees with CSCS or Accredited Card.....</td> <td></td> <td></td> </tr> </table>		Employees	Sub-contractors	Induction Training	YES/NO	YES/NO/N/A	Supervisor Management	YES/NO	YES/NO/N/A	Safe System of Work (i.e. Risk Assessments etc.)	YES/NO	YES/NO/N/A	CSCS or Accredited Scheme	YES/NO	YES/NO/N/A	Percentage of all employees with CSCS or Accredited Card.....																																
	Employees	Sub-contractors																																															
Induction Training	YES/NO	YES/NO/N/A																																															
Supervisor Management	YES/NO	YES/NO/N/A																																															
Safe System of Work (i.e. Risk Assessments etc.)	YES/NO	YES/NO/N/A																																															
CSCS or Accredited Scheme	YES/NO	YES/NO/N/A																																															
Percentage of all employees with CSCS or Accredited Card.....																																																	
5	How frequently do you monitor your employees safety performance on site: Tick as appropriate Constantly <input type="checkbox"/> Daily <input type="checkbox"/> Weekly <input type="checkbox"/> Other, Specify..... 5.1 Who carries out the above monitoring? Tick as appropriate Site Supervisor <input type="checkbox"/> Safety Advisor <input type="checkbox"/> Company Official <input type="checkbox"/> 5.2 How is this demonstrated : Tick as appropriate Written report with a copy left on site <input type="checkbox"/> Informal communication with the Site Manager <input type="checkbox"/>																																																
6	Do you undertake any designs within your organisation? Tick as appropriate YES <input type="checkbox"/> NO <input type="checkbox"/> 6.1 If Yes how do you comply with your Designer duties under CDM?.....																																																
7	<table border="1" style="width:100%; border-collapse: collapse;"> <tr> <th colspan="7" style="text-align: center;">Accident Statistics for the Previous 3 Years</th> </tr> <tr> <th rowspan="2"></th> <th colspan="2" style="text-align: center;">Last Year</th> <th colspan="2" style="text-align: center;">The Year Before</th> <th colspan="2" style="text-align: center;">The Year Before That</th> </tr> <tr> <th style="text-align: center;">Employees</th> <th style="text-align: center;">Sub-contractor</th> <th style="text-align: center;">Employees</th> <th style="text-align: center;">Sub-contractor</th> <th style="text-align: center;">Employees</th> <th style="text-align: center;">Sub-contractor</th> </tr> <tr> <td style="text-align: center;">Average No of Employee's</td> <td></td> <td></td> <td></td> <td></td> <td></td> <td></td> </tr> <tr> <td style="text-align: center;">Major Classified Injuries</td> <td></td> <td></td> <td></td> <td></td> <td></td> <td></td> </tr> <tr> <td style="text-align: center;">Over 3 days lost time</td> <td></td> <td></td> <td></td> <td></td> <td></td> <td></td> </tr> <tr> <td style="text-align: center;">Fatalities</td> <td></td> <td></td> <td></td> <td></td> <td></td> <td></td> </tr> </table>	Accident Statistics for the Previous 3 Years								Last Year		The Year Before		The Year Before That		Employees	Sub-contractor	Employees	Sub-contractor	Employees	Sub-contractor	Average No of Employee's							Major Classified Injuries							Over 3 days lost time							Fatalities						
Accident Statistics for the Previous 3 Years																																																	
	Last Year		The Year Before		The Year Before That																																												
	Employees	Sub-contractor	Employees	Sub-contractor	Employees	Sub-contractor																																											
Average No of Employee's																																																	
Major Classified Injuries																																																	
Over 3 days lost time																																																	
Fatalities																																																	
8	Have you been in receipt or pending any enforcement action by the Enforcing Authorities (HSE, Local Authority & EA)? Tick as appropriate YES <input type="checkbox"/> NO <input type="checkbox"/> 8.1 If yes please provide details of any such enforcement:.....																																																
9	requires documented safe systems of work (risk assessment, method statements, COSHH assessments etc.) for all work activity, please provide 2 examples your company uses. 9.1 How are safe systems of work communicated to your workforce?.....																																																
10	Please tick as appropriate your companies membership of any of the following Safety Groups or Trade Associations: Royal Society of the Prevention of Accidents (ROSPA) <input type="checkbox"/> British Safety Council (BSC) <input type="checkbox"/> Local Health & Safety Groups <input type="checkbox"/> Trade Association, please specify:.....																																																
NB: Unless already stated proof of accuracy of the information requested may be requested by the Group																																																	
Completed by (Capitals)	Title:																																																
Signature:	Date:																																																
Evaluation																																																	

Figure 47. Subcontractor safety questionnaire

It was reported that road-related collision statistics were not considered when selecting subcontractors, or were not considered to the same extent as on-site health and safety:

"If the accident was on site, whether it's with a vehicle or whether it's just a general accident, yes, I'd have to consider that. Out on the road, it's...I suppose it's all down to fault, who's at fault with the accident, isn't it? I don't know. I'm not sure, if I was honest...If it was the fault of the lorries or something like that, then yes, we'd consider not using the company again." (Primary Subcontractor)

The process of sub-subcontractor selection was explained by one of the tertiary subcontractors:

"What happens is that the contractor is given tables of analysis [regarding soil] from the client...that's then given to the [Secondary Subcontractor] for costings. They send that to [our organisation] ...then [the Secondary Subcontractor] chooses the contractor, i.e. in this situation [our organisation] to haul the soil and stone away." (Tertiary Subcontractor - manager)

It seems that subcontractors often subcontract aspects of their work based on geography, in order to save on both time and fuel costs:

"We've got a couple of landfill facilities...but in this case, [Tertiary Subcontractor, whose facilities are more local to the site] are taking it to their landfill facilities...it's cheaper than us taking it to our one, you know?" (Quaternary Subcontractor)

7.2.3.3 Contracts and payments

The Tertiary and Quaternary Subcontractors reported that they were paid per load, although the drivers themselves are salaried:

"It's per load...obviously we negotiate, even the sales director actually negotiates with the client. And obviously our client is negotiating with other companies like ourselves and...But, basically, yes, it does come down to pounds, shillings and pence." (Tertiary Subcontractor - manager)

During busy periods, the Tertiary Subcontractor will employ drivers and vehicles from other small organisations (i.e. Quaternary Subcontractors) to help meet demand. These quaternary subcontractors may include owner-drivers (although this was not the case for the Quaternary Subcontractor interviewed), and will be paid per load. Despite being subcontracted to the Tertiary Subcontractor, they are trained by the Tertiary Subcontractor and are expected to adhere to the same policies as the Tertiary Subcontractor's own drivers. It was reported that there is no difference in productivity between their own drivers and subcontracted drivers:

"We all work pretty much as a team...everybody adheres to our policies and it works very well. We've got a very good relationship with our operators...all their vehicles have to adhere to all the policies that ours do...if they are to be utilised by [us] then they have to pretty much have everything on their truck that we have on our trucks." (Tertiary Subcontractor - manager)

7.2.3.4 Management of driver safety

The responsibility for safe driving was again perceived to lay with individual drivers:

"Once a lorry leaves the site, it becomes their responsibility as a lorry driver, i.e. keep to the law of the road, really." (Primary Subcontractor)

7.2.3.5 Communication and reporting

The construction manager at Site 2 indicated that, if a vehicle driving to or from the site was involved in a collision, there would be no expectation that this would be reported to the Principal Contractor:

"Generally if someone [was involved in a collision], no, we wouldn't know."
(Principal Contractor)

Additionally, it was stated that if a collision was reported, the Principal Contractor would not be in a position to act on the information:

Interviewer: *"If you did find out about a collision off-site that one of your subcontractors was involved in, would you do anything about it?"*

Respondent: *"I'm not sure we can. I'm not sure what jurisdiction we have on the public highway, you know. What can we do?"* (Principal Contractor)

This held true for subcontractors:

"Well, no, if I was honest the only way I'd probably hear about it is if I was expecting a delivery and I started chasing why it isn't here." (Primary Subcontractor)

Interviewer: *"Would you report [a collision] to your customer on-site or would you solely report that within [your organisation]?"*

Respondent: *"No, it's reported immediately to the management at [organisation]...if it occurs on a construction site, then obviously everybody is informed."* (Tertiary Subcontractor - manager)

"It would stay within [the tertiary subcontractor]...but we tend to hear it, you know." (Secondary Subcontractor)

7.2.3.6 Driver pressure

As with Site 1, drivers are allocated a time slot for deliveries. Site 2 operates 15-minute time slots:

Respondent: *"We've got 15-minute slots."*

Interviewer: *"So what happens if they're late?"*

Respondent: *"If they're booked in, then it gets sent away...I suppose it's the same as anywhere. If you're got to be somewhere on time, yeah, then there is more pressure. But on the flipside of it, you can't have everyone turning up ad hoc because then you can't manage it."* (Principal Contractor)

It was reported that time slots of this length were impractical, particularly given the absence of a holding area for vehicles:

"It's humanly and physically impossible. If you had a parking place where you could park them and say you can't come in until 11.30...there's no parking anywhere. There's just nothing...if a driver has to be here at half past 11 and he's 20 minutes late, I would have thought human nature would make him speed up a bit to get in here before I turn him away...their idea of 15 minute slots, I don't think it's sensible." (Primary Subcontractor)

7.2.4 Construction Site 3

7.2.4.1 Interviewees

Construction Site 3 is a large multi-site London-wide rail development. Four sites within Site 3 were visited. These will be referred to as Sites 3a, 3b, 3c and 3d.

The client was a public-private partnership and the project duration is nine years. At the time of the visit, construction had been underway for three years. TRL researchers visited the sites in August 2012 and carried out 13 interviews face-to-face and one over the phone:

- Client: Driver training programme manager
- Site 3a Principal Contractor: Traffic manager and two drivers
- Site 3a Primary Subcontractor: Distribution services manager
- Site 3b Principal Contractor: Logistics manager
- Site 3b Primary Subcontractor: Driver (aggregates/waste disposal)
- Site 3c Principal Contractor: Logistics manager and driver
- Site 3c Primary Subcontractor: On-site supervisor (waste disposal)
- Site 3c Primary Subcontractor: Driver (large goods e.g. pilings)
- Site 3d Principal Contractor: Logistics/transport manager and on-site supervisor/driver
- Site 3d Primary Subcontractor: Driver (large goods e.g. pilings)

The interviewees and their positions in the network are shown in Figure 48. Principal Contractors were typically joint ventures, and were different at each site.

7.2.4.2 Management of driver safety

The project is highly safety-focused with particular attention being paid to driver and cyclist safety. The emphasis on cyclist safety is the result of a legal responsibility placed on the project and has resulted in a requirement for all drivers of LGVs who visit a site five or more times per year to attend a day-long lorry driver induction course, which concentrates on cyclist safety. Drivers making fewer than five trips annually are issued with an information pack. In addition all vehicles visiting sites are required to comply with a list of requirements, most notably sensors and other safety equipment that alert drivers to the presence of cyclists. Vehicles which do not comply with the requirements are turned away from the site. There are two features which distinguish this project from the majority of construction projects: the client's ownership of driver health and safety, and the inclusion of off-site driving in health and safety policies.

"The health and safety element is a priority...we've got a whole range of initiatives that address both the behaviour of the driver and the culture of the company, and by addressing both and aligning drivers and companies with Target Zero golden rules, that's how we address work-related road safety...we've treated health and safety as being ubiquitous across the whole project, and the journey to and from the work site." (Client, Site 3)

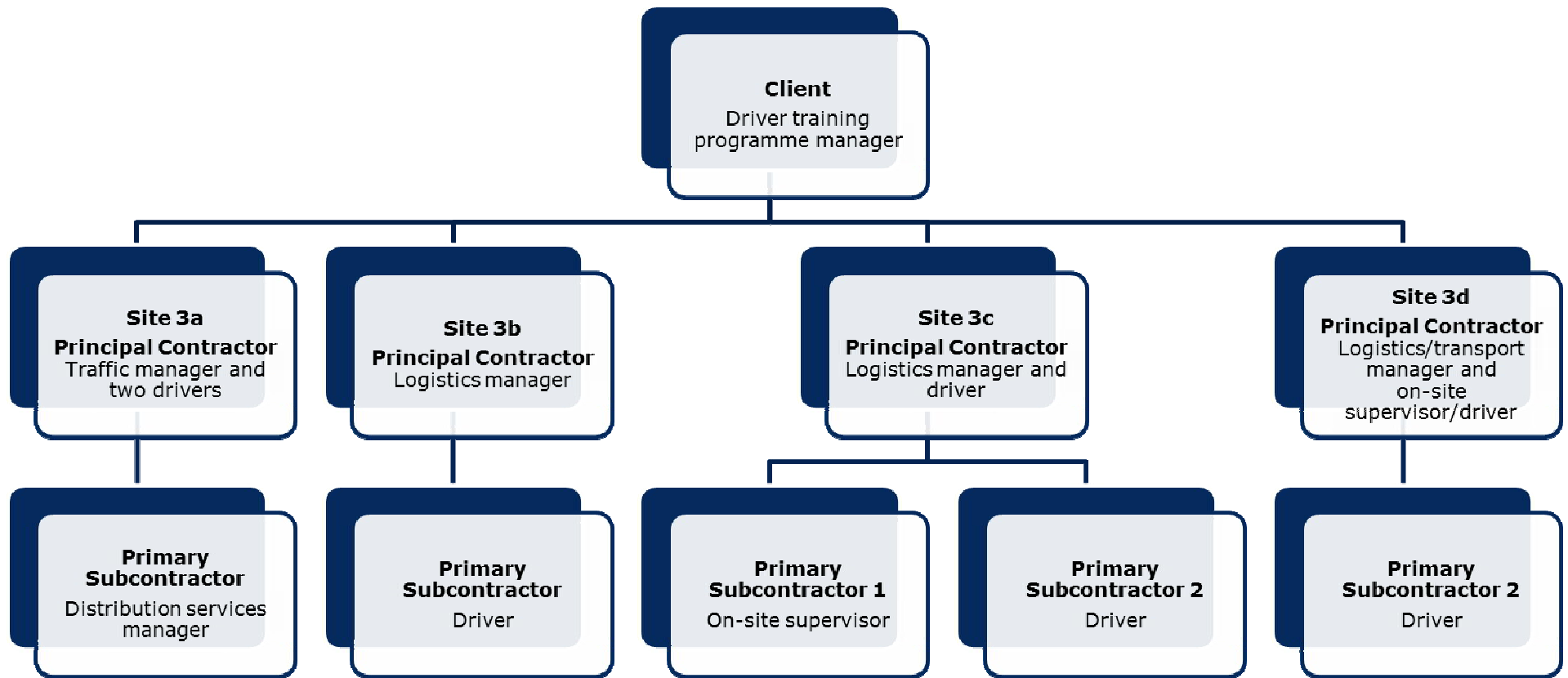

Figure 48. Construction Site 3 interviewee network structure

7.2.4.3 Selection

A principal contractor described the subcontractor procurement process:

"We have an extensive procurement process, a minimum of three suppliers are always put forward for tender... companies are scored after each contract and that will be taken into consideration with regards to previous performance. There's a selection matrix that effectively looks at previous performance, quality, safety record, price, compliance, and then that's all churned together in a scoring matrix and then you pick a winner and then you have an interview with them to see if they're still the right one." (Principal Contractor, Site 3d)

It was stated by another principal contractor that value for money is not the only consideration:

"It is knowledge of the industry in this area...so we are not interested in cost...the people we want [to be] involved get involved, and they are those that we know the industry trusts." (Principal Contractor, Site 3c)

In addition the subcontractor's location and knowledge of driving in London is taken into account:

"Local companies know the roads, know just what's required in London. If I bring somebody in from outside of town and have them driving around London, they're not so used to driving in London, so I'd rather have locals. Plus, obviously at night...they've got to park up somewhere, that no good if they've got to drive miles away...we consider it price against value against location." (Principal Contractor, Site 3c)

At Site 3a, the Principal Contractor employs two drivers whose sole responsibility is to pick up goods from one site and deliver them to Site 3a – a journey of a few miles using an assigned route. In addition a Primary Subcontractor is used to supplement the two permanent vehicles when necessary. The Primary Subcontractor was selected based on its locality to Site 3, and all drivers have been inducted. It was stated by one principal contractor that an organisation's collision record would not be checked prior to them being selected as a subcontractor:

"If they're FORS registered and they're [Client] compliant then that's sufficient; there no other requirement to meet there...we'll go out and vet them as well, and we'll go out and have a look at them if they need us to, just to check over to make sure they're happy with the safety equipment." (Principal Contractor, Site 3a)

However this practice seemed to vary by site, with another principal contractor reporting that collision rates would be considered:

"We also investigate what their history is of the accident rate prior to awarding a contract...that is driving accidents for the haulier but they will also be asked an audited on their system." (Principal Contractor, Site 3c)

In addition to attending the lorry driver induction course, drivers (at some sites if not all) undergo initial and ongoing assessments:

"When we first come on, we go and have a two day driving assessment to make sure you're capable of doing the job. And then they will get in the cab with you

every now and again just to make sure that you're staying conscious of what you're doing." (Principal Contractor - driver, Site 3a)

7.2.4.4 Contracts and payments

There is a "no pay-per-load" policy in place for all contractors at Site 3. A works information document is distributed to the principal contractors working on Site 3, and this includes a requirement that hauliers will not incentivise drivers by the journey or the load. In terms of dissemination of this information, responsibility lay with the principal contractors rather than the client:

"That would be the responsibility of the principal contractor to ensure it is cascaded and communicated." (Client, Site 3)

Principal Contractors were aware that pay-per-load was not an option:

"There's a policy that...nobody works on piece rate or rate bonus...safety is the priority. I don't want anybody rushing because they feel they ought to...and that's drilled into them from day one, they drive safely first." (Principal Contractor - manager, Site 3a)

"[The contract with the Primary Subcontractor] is on a day rate...while the drivers are with us they're under my control, or my two assistants." (Principal Contractor - manager, Site 3a)

Owner-drivers are general not involved in Site 3, with the exception of those who work for a larger organisation but own their own vehicle:

"No owner-drivers. The only ones that do come in, perhaps, are the concrete deliveries, because they're mainly owner drivers, but they're got to have come from [large organisation] or somebody like that." (Principal Contractor - manager, Site 3a)

General interviewee 3 described how owner-drivers (who then use liveried vehicles) are contracted:

"Because we take them on as a subcontractor, it's a little bit different, it's not like employing a driver so we look more at their business rather than them as individuals. Obviously, a lot of them are already known because they've worked elsewhere for other companies or whatever." (General interviewee 3)

In the case of owner-drivers, pay-per-load is commonly used:

Interviewer: "Do you pay them per load they deliver for you?"

Respondent: "Per load, yes." (General interviewee 3)

This interviewee did not feel that this payment method would necessarily result in drivers trying to achieve more deliveries in a day:

"It'd be difficult to argue against it, I suppose, but...the reality is that because they can contact us, you know, we will try and push them to work a full day but sometimes they like to finish early, so it wouldn't suggest that they're chasing money all the time." (General interviewee 3)

7.2.4.5 Communication and reporting

When asked whether communication differs between Site 3 and other construction sites that the interviewee had worked on, it was stated that:

"They're quite hard task-masters to a degree, you know, the rules are there and they expect us to stick by them, and we do, you know. But having said that, it's not a matter of a big stick or anything like that, we work very much... contractors and [the client] work very much as a team in, you know, producing this project for London, as simple as that." (Principal Contractor, Site 3b)

Safety messages are communicated to drivers at all levels of the supply chain using a variety of methods:

"I produce safety alerts and bulletins and best practice advice and put those out formally into the supply chains... I've just done a whole series of four of those in areas that just need a little reinforcing, you know, whether they're doing it 100% or 75%, I'm always keen to see areas being reinforced that could pose a risk." (Client, Site 3)

"I've also set up an online forum, which is a resource which has about 100 members now and is used mainly by our subcontractors and principal contractors...so questions that may come up that are valid, I post on the site. So that's a great way of communicating and then people can't say, well, no one's told us about that. You know, it's there and I know who uses it and who doesn't use it and I make sure that they know it's there." (Client, Site 3)

In terms of reporting collisions, any collision occurring on a journey to or from Site 3 would be treated in the same way as an on-site incident:

Respondent: *"It's treated as an accident onsite and it's reportable...it's got to be reported by the principal contractor responsible for that subcontractor through the health and safety report system."*

Interviewee: *"So that all gets fed up to you as a client..."*

Respondent: *"It does, yes...we would get involved and look at the company involved and if we conclude that the company should be reminded that there are lessons to be learnt, then we would advise the principal contractor."* (Client, Site 3)

"I would expect to hear about [an off-site collision]...we have a reporting system through [the client]." (Principal Contractor - manager, Site 3a)

"In theory from the time [a driver] leaves his depot and he gets to our site and he leaves our site and he gets back to his depot, in theory he's on [the client's] business. If he has an accident in that time, then they have to report it to us and we then have to report it to [client]." (Principal Contractor - Site 3b)

This is in contrast to the majority of construction sites whereby an off-site collision would be reported internally, but the principal contractor or client may never be informed that a collision had occurred involving a vehicle driving to or from the site. However, whilst this is the official line, it is not always communicated to all workers involved in Site 3. For example, at Site 3c, an on-site supervisor (who all drivers report to when arriving at the site) stated that a collision occurring away from the site would not be reported on the site:

Interviewer: *"So would you report [a collision] to the site management here?"*

Respondent: *No, because it's in the roads, it's nothing to do with the site. So if it happens on site then it's generally, it's a totally different story, but if it happens in the street then it's down to whoever it is...these people have got enough to do."* (Primary Subcontractor 1, Site 3c)

And at Site 3d, the Principal Contractor stated that, as logistics and transport manager, he would not expect to receive a report of any incidents that a subcontractor was involved in off-site:

Respondent: *"Unlikely [to receive a report] as he's not, we don't deal as being onsite until he arrives either in the lorry holding area or through the gates...ultimately we would, potentially, but I can't see the mechanism...it's not happened on this site..."*

Interviewer: *"There's nothing in their contract that you remember that requires action?"*

Respondent: *"No, nothing that I can remember."* (Principal Contractor, Site 3d)

Another area in which Site 3 distinguishes itself from many other construction projects is the inclusion of near miss reporting, both on-site and off-site (although no off-site near misses had been reported to date; despite it being a contractual requirement, under-reporting may still be an issue):

"Near miss reporting is a requirement...we've seen near misses associated with deliveries when they get to the worksite...the difficulty with any near miss is that if it happens away from somewhere where people in authority are, then it's unlikely to be reported, which is a shame and it's very much a cultural thing." (Client, Site 3)

This was verified by drivers:

"I would [report a near miss], yes. But to be fair, you can sit and write them up all day...you would sit and do paperwork for three hours in the night if you had to put every incident down that would be classed as a near-miss. So you've got to use your common sense." (Principal Contractor - driver, Site 3a)

There was a suggestion that, in addition to the culture of an organisation, and the time taken to file a near miss report, there may be another reason for under-reporting:

"They don't want to get themselves told off, because if they did start reporting the [near miss] incidents they'd get loads of trouble and a load of aggravation." (Primary Subcontractor 1, Site 3c)

7.2.4.6 Driver pressure

A common practice on Site 3 is for drivers to have specific route plans for their deliveries, with roads that may and may not be used to drive to and from sites. Due to the large scale and central locations of Site 3, these routes were planned in consultation with local authorities, businesses, residents and community police.

Interviewer: *"Did you consider cyclists and vulnerable road users during the planning of the routes?"*

Respondent: *"Yes, that's where the local communities were involved."* (Client, Site 3)

Pressure placed on drivers by meeting certain delivery time slots is reduced by the presence of a lorry holding area at each site where vehicles may wait until the site is ready to receive them.

Therefore if a vehicle misses its assigned time slot, there is an option of waiting in the holding area until they are able to go on site.

Interviewer: *"So if someone was late for their slot, what would happen?"*

Respondent: *"They'd go to the lorry holding area, until such time as they could call to site and be allowed onto the site...at present we have not needed to turn anyone away for being late."* (Principal Contractor, Site 3d)

Drivers at Site 3a are asked to aim for a certain number of deliveries per day, but are not placed under any pressure to meet this:

"They request so many deliveries and if you can do it, you can do it. There's no, for example this week they want five...but if we can't do them, we just don't do them." (Primary Subcontractor - driver, Site 3a)

7.2.5 Comparison of general haulage and construction contracts

In order to compare the construction industry with general haulage, an interview with a large haulier was carried out (the legal operations manager, in a large retail partnership).

In addition, interviewees who took part in the construction site interviews, and the 'general interviewees' (some of whom had worked in both construction and haulage) were asked for their views on any differences between the two industries.

Haulage drivers have a similar task to construction vehicle drivers in that both, on a basic level, involve transporting goods from one site/depot to another. However the key differences are described below.

7.2.5.1 Type of goods transported

Loads will differ both within different areas of general haulage, and between haulage and construction, but the overall task is essentially the same:

"Certain principles of transport, whether you're delivering yoghurts, bananas, bricks or steel, you've still got a vehicle and a driver..." (General interviewee 4)

It was suggested that loads could be more dangerous for a construction vehicle driver, particularly when it comes to loading and unloading:

"[The load] could be a difficult load to get out of the lorry, could overhang if you get it wrong. We're loading with a machine. Normal hauliers, curtain-siders or whatever, they're loaded properly with forklifts, everything's tied up, everything's checked, everything is tied down." (Principal Contractor, Site 3c)

Haulage drivers will often carry perishable goods, particularly in the case of supermarket/food deliveries. Similarly construction drivers transporting concrete are transporting a perishable item, typically with a limited guaranteed life. Transporting these types of goods can place pressure on the driver:

"If they [the depot] do not feel happy with the goods, they can refuse to take the goods, so that could pose a problem." (Haulage interviewee 1)

7.2.5.2 Loading/unloading

The features of the unloading area also vary, with general hauliers often unloading into a loading bay, whereas construction vehicles may be required to navigate a construction site with which they may not be familiar:

"If you do RDC [regional distribution centre] work, which is basically depot to depot...you've got this massive, open concrete area with about 45 doors. You reverse onto it. It's easy; a baby can do it." (Primary Subcontractor, Site 3d)

7.2.5.3 Types of driver

One interviewee suggested that the two industries may attract different types of driver:

"You would think a driver was a driver but they're not. It is different, not in terms of the driving standards. It's just a different mentality in terms of if you take a [general haulage] driver, they would not transfer over straight to, you know, a concrete job...it's just horses for courses." (General interviewee 3)

7.2.5.4 Roads used

Many haulage journeys will terminate at an out-of-town depot, whereas many construction journeys (especially in London) will terminate in a construction site in an urban area:

"[With general haulage] you're driving down the motorway, you come off the motorway for about a mile... all the main depots like the main like B&Q and Asda and all that kind of stuff, they're literally just like a mile off the motorway for that reason, to make it easier for the driver. Whereas obviously construction they pop up everywhere and anywhere, which seems to be a problem for us to get to because if, sometimes it is a bit of a nightmare to get to them... Coming into London or Liverpool or Glasgow or wherever or any of the main cities, central London, little streets like this, they're totally different. It's a lot harder." (Primary Subcontractor, Site 3d)

Interviewees also noted that due to the transient nature of construction sites, it is more likely that drivers will not be familiar with the site or the surrounding roads, compared with haulage drivers who will often deliver to the same depot. The roads may also be less suitable for large vehicles, particularly where the construction site is new or will exist only for a short period of time:

"They're often delivering and collecting on roads that aren't – I wouldn't say aren't designed for HGV vehicles...If you go across London there's no motorway and it's all congested, you're trying to move big vehicles on roads that haven't got as much turning room, as much space as motorways...on a construction site that's in its infancy, there aren't any give way lines, there aren't any traffic lights...there isn't the, you know, there isn't the same format as there is on a normal road...and there isn't a defined bay for loading, there isn't a defined bay for collecting so it's a bit more primitive, really." (General interviewee 4)

It was also suggested that construction drivers are likely to cover a smaller area than general haulage drivers:

"In terms of like having been in aggregates now for about six months [having previously been in haulage], the things that strike me first of all are, one is the

majority of the mileage that a vehicle does is within a short range of its base".
(General interviewee 4)

7.2.5.5 Use of agency drivers

Agency drivers appear not to be used to any great extent in the construction driving industry, but are commonly used by hauliers. For example interviewee 1 stated that their organisation uses a couple of hundred agency drivers a week:

"Some of it is short term and some drivers are probably here for longer for that and some drivers probably go away but will come back again at some stage."
(Haulage interviewee 1)

This may have an effect on the overall safety of the organisation, depending on how drivers are recruited, inducted, trained, paid, and informed of the organisation's policies and procedures. Agency drivers may be more likely to be involved in a collision than permanent employees; in the case of one retail depot, agency drivers made up 6% of hours worked but were responsible for 17% of collisions (Brake, 2006). Therefore it is imperative that organisations ensure that agency drivers comply with their own policies and procedures.

7.2.5.6 Vehicle maintenance

Whilst there is no reason for there to be any differences between the two industries in terms of how vehicles are checked and maintained, one interviewee did point out that construction vehicles are prone to becoming dusty when on a construction site. It was felt that this should be checked prior to a lorry leaving the site (e.g. are all mirrors clean, are all signs legible?):

Respondent: *"It's really their [the site's] responsibility, if the lorry's dirty, they need to wash their lorries."*

Interviewer: *"So you think that's up to them as well as you?"*

Respondent: *"Oh definitely, yes."* (General interviewee 6)

7.2.5.7 Contracts

Construction sites will generally have a greater number of subcontractors (primary, secondary, tertiary etc.) than are in place for haulage companies. For example Haulage interviewee 1 stated that in their large fleet of over 2,000 vehicles, only 60 are subcontracted from another logistics organisation, and that was the full extent of subcontracting. By contrast, a greater number of organisations and individuals is involved over the life of a typical construction project:

"So you're going to get a massive range of contractors [on a construction site], small one-man-bands, self-employed people, whereas really transport [i.e. general haulage] is more of a – especially when there's some big contracts – is more on a one-to-one basis and it isn't subcontracted so much." (General interviewee 4)

The way that the contracts are set up may also differ between haulage and construction:

"I think construction contracts themselves would be far more detailed. They would be subject to a lot more scrutiny. They would be awarded through procurement procedures that are transparent and visible and auditable. I think

with haulage companies, I think like many trades, the further down you go in the supply chain, the smaller the company, then contracts may not be...and I have no evidence to support this in our particular project, but I know from experience that contracts may not be as robustly written as one would like to think and that in itself could be a weakness in terms of cascading responsibilities that people are paid for to deliver.” (Site 3 Client)

7.2.5.8 Driver payment

Those interviewed who worked (or had worked) in the general haulage sector stated that the majority of drivers were employed by that organisation, and therefore were paid a salary for their work. When necessary agency drivers were used to support the employed drivers and they would be paid a day rate. In the case of the construction industry both employed drivers and owner drivers were used, depending on the organisation. For some organisations only employed drivers were used, who were paid a salary, however when necessary owner drivers (or small firms) were used to support the employed drivers, who would normally be paid a rate per delivery. In other organisations only owner drivers were used, who were paid per delivery.

There were, however, no perceived differences between how the payment methods used for drivers in the two industries impacted on their driving:

“[In both sectors] you’re providing the product, you get paid within so many days...We’re not allowed to pay our drivers any incentive which, in fact...The Road Traffic Act... I can’t remember the exact details but, you know, you’re not allowed to pay drivers an incentive which might encourage them to carry more loads or speed or break the law in any way so, no, that, I’m not aware if that goes on. It might do but I’ve got no evidence that it does go on.” (General interviewee 4)

7.2.5.9 Industry standards

The legal and contractual expectations of construction and general haulage vehicles/drivers can vary, and a desire has been expressed for greater consistency (both within and between the two industries):

“The biggest concern would be that we’re getting different standards depending on the customer...we need to just get a standard that we agree is safe and that we agree as being all the things that we want to do and try and sort of standardise that rather... so that everybody’s happy that that’s the agreed [?] standard and a safe standard...I think that would be a real benefit if we could do that really across the industries.” (General interviewee 3)

7.2.5.10 Focus of driver safety

The focus of driver safety for those driving construction vehicles tends to be very much on-site, as construction sites are clearly dangerous places to work and drive. However this can be to the detriment of ‘on-road’ driver safety once the driver has left the site, as reported in many of the interviews. In comparison, most general haulage drivers do not deliver to dangerous sites and any health and safety training relating to driving will be focused purely on driving on the roads.

Since construction drivers tend to drive within a smaller radius of their depot, transport managers may be in more regular contact with them compared with general haulage drivers who may drive hundreds of miles:

"Because construction is lots of short-haul, short distances, you're more likely to speak to the drivers than if you're sending a driver on a long-haul delivery."
(General interviewee 4)

This presents a good opportunity for those managing construction drivers on a day-to-day basis to keep up-to-date with any issues or problems that the driver is facing, gather near miss reports, and spread safety messages.

7.2.5.11 Ownership of driver safety

As stated above, construction driver safety while on a construction site is a key concern. The principal contractor takes responsibility for the health and safety of all workers on the site, but once a driver leaves the site, principal contractors commonly report that the driver's safety is no longer their responsibility. The client is generally not concerned (contractually) with the safety of drivers delivering to the construction site. Table 31 illustrates the typical level of ownership of driver safety both on-site and off-site. The ownership of construction vehicle driver safety typically rests with their employer (who may be a subcontractor, or the driver himself in the case of owner-drivers). In contrast, a haulage driver working for a large delivery company will be working directly for the client, who will have a vested interest in the driver's safety. It is worth noting that this is a generalisation, and there may be cases of haulage drivers working for a subcontractor who takes ownership of their safety, rather than the client taking ownership, which would be a more similar model to the majority of construction sites.

Table 31. Typical level of ownership of construction vehicle driver's safety by different stakeholders, on-site and off-site (for secondary subcontractor level driver)

Stakeholder	Level of ownership of driver's safety <i>on-site</i>	Level of ownership of driver's safety <i>off-site</i>
Client	Medium	Low
Principal contractor	High	Low
Primary subcontractor	Medium/high	Medium/low
Secondary subcontractor (driver's employer)	High	High

7.2.6 Summary of interview findings

7.2.6.1 Management of driver safety

In general, it was found that any ownership of a driver's safety tends to end once the driver leaves the construction site, for all stakeholders bar the driver's own company. The driver and their transport manager are typically held responsible for the driver's safety, with a widespread belief amongst drivers that they should 'just be sensible' on the roads. Whilst drivers are indeed responsible for ensuring the safe transportation of goods to or from the construction site, their employer, and clients further up the chain, all have a role to play and could be subject to scrutiny in the event of a Corporate Manslaughter investigation. HSE summed up the problem by stating that:

"In some situations other parties may be involved [in delivery]. For instance, a recipient may place an order with a supplier who arranges for a third company to provide the goods, who in turn arranges for a haulier to make the delivery. Such complex arrangements can easily go wrong due to misunderstandings and failures in communication. The dangers of this should be considered before entering into these arrangements. If a delivery accident occurs, all parties in the chain may be asked to show that they took all reasonable steps to co-operate to achieve safety." (HSE, 'Delivering Safely')

Statistics relating to on-road collisions are often excluded from an organisation's overall safety statistics, meaning that the organisation themselves and any clients/subcontractors may be unaware of the magnitude of the issue surrounding off-site driving safety.

7.2.6.2 Selection

CLPs are a valuable tool but are not generally used in selecting contractors. There is great scope for developing this area. As described further on in section 4, CLPs address elements of construction sites which may pose a threat of collision to cyclists (e.g. the transient nature of construction sites and drivers being required to use often unfamiliar routes) and so principal contractors should be required to submit a full CLP during the selection process.

The requirement for contractors to be FORS accredited is a part of the selection process in some organisations – which is sensible – but it is important that the client or principal subcontractor ensures that this accreditation is monitored. There is a risk of organisations gaining accreditation in order to secure contracts, but subsequently not taking an active interest in FORS and its requirements and guidance.

Safety statistics are often inspected during contractor procurement, but in the majority of cases the key concern is on-site collisions. Driver safety, particularly off-site, is not considered in the vast majority of cases.

The selection of subcontractors and drivers can be based on their location relative to the construction site, and their knowledge of the local roads. In some cases this may be given more weight than the organisation's safety record, or training taken by drivers.

7.2.6.3 Contracts and payments

Pay per load is generally not used for drivers within the construction industry, with the common exception of owner-drivers, for example those operating a cement mixer owned by the driver but displaying a large organisation's livery. However organisations may be paid per load resulting on indirect pressure on drivers who, though salaried, are aware that their employer depends on them completing a given number of journeys per day.

Contracts are usually more complex on construction sites than in general haulage, due to the nature of the work which involves many different areas of expertise to complete a project. The organisations involved at all levels of the contract network will each have areas in which they specialise, but typically, none will specialise in driver safety. It is therefore important to ensure that driver safety is included as an element of all contracts, specifying areas such as how driver safety is managed, policies and procedures, driver selection/training, and driver safety statistics.

7.2.6.4 *Communication and reporting*

Off-site collisions are generally only reported within the driver's own company, and would not be reported up the chain. Principal contractors and clients are particularly unlikely to be informed about any off-site collisions relating to their project. Optimal communication between the different levels of the network is key so that all parties are aware of any incidents and are therefore able to improve planning to mitigate any further incidents.

HSE state that "*...all parties should set up simple, well understood systems for reporting any vehicle accidents, incidents, near-misses and other safety concerns during deliveries and collections, and exchanging information with other parties*" (HSE, Delivering Safely). The reporting system should be simple, as drivers often perceive it to be time-consuming (especially for near misses which may occur frequently in London). Drivers may also be concerned that by reporting very minor incidents and near misses, they are increasing the chance that they will be asked to undergo further training or assessments, which would discourage them from submitting a report. Drivers can be encouraged to report any concerns or incidents, for example by introducing an incentive scheme, and should also be informed of the likely outcome of making a report, as well as being advised of the importance of reporting.

Safety messages are generally satisfactory, but organisations should ensure that all their drivers receive and understand the messages. It is important to ensure that the right people receive messages at higher levels (i.e. principal contractors, clients) and that they cascade them down through the construction site network. In addition the flow of safety messages through the network should be fully audited. There is a perceived need for greater awareness of the problem of off-site incidents involving construction vehicles, and the laws that are applicable to this area (in particular Corporate Manslaughter).

7.2.6.5 *Driver pressure*

Whilst assigned delivery time slots are effective at ensuring a smooth and well-distributed flow of traffic into and out of construction sites, there is a danger that they will place pressure on drivers to arrive at the site by a certain time, which may result in the driver taking more risks or breaking the speed limit. This could be alleviated somewhat by extending the time slot (for example an arrival window of 15 minutes seems less reasonable than one of 30 or more minutes) or by being more lenient on drivers who arrive late – rather than turning vehicles away, construction sites should attempt to allow the delivery to go ahead wherever possible.

Lorry holding areas are also an effective way of relieving pressure on drivers and ensuring that there is minimal impact on traffic around the construction site.

8 Findings

The current project addressed the following general research themes:

1. Is it possible to understand the relative risk represented by construction vehicles to cyclists, when compared with general haulage vehicles? If so, what is it? What are the limitations in the data available?
2. Are there features of contractual arrangements, working practices, driver behaviour, or vehicle design (or combinations of these) that contribute to the apparent over-involvement of construction vehicles in fatal collisions with cyclists in London?

In this section, we discuss the key findings related to these themes, taking into account all of the data gathered in the project.

The findings from this work are based on the statistical analyses, observed drives, vehicle scanning work, and interviews carried out with members of three construction site networks (as well as some additional interviews). Whilst the data gathered from the interviews provided a valuable depiction of how construction sites operate in terms of contracts, driver safety management and communication, the driving task itself, and the vehicles used, the relatively small sample size (in comparison with the number of construction sites within London) means that the findings will not necessarily apply to all construction sites or operators.

It should also be noted that due to the fact that this project took a broad (and largely qualitative) approach to the area, a definitive statement as to the *quantitative* differences between construction and general haulage is not always possible. As demonstrated, there is great variability in the operation of construction sites (even within the exemplar site used, variability was found) and this should be borne in mind when considering the findings and recommendations. The outputs of the project are nonetheless representative of construction networks (regardless of organisation role or size), and represent opportunities to increase the safety of cyclists in relation to the risks they face from construction traffic.

8.1 General findings

General finding 1: Road risk is viewed as less important than general health and safety risk (see recommendations 1,2 and 3)

The construction industry does not appear to be immune to the wider neglect of work-related road risk seen even in those organisations that represent good practice (see Helman, Buttress & Hutchins, 2012); at the operational level the construction industry does not ascribe road risk the same level of importance as general health and safety risks when selecting who to work with, and when managing safety performance. See sections 7.2.2, 7.2.3 and 7.2.4 for supporting quotes.

This finding, although not specific to the construction industry, sets the context in which all the other findings from this project should be viewed; in the construction industry as in other sectors, the management of work-related road risk clearly lags behind the management of more general health and safety. Therefore even if *only* considering the exposure to risk in London (see general finding 2) that arises from construction traffic,

changes to general work-related road safety practice have the potential to have a large impact on cyclist safety.

General finding 2: Although road casualty statistics make it difficult to identify industry sectors associated with collisions, construction traffic appears likely to be over-represented in collisions with cyclists (see recommendation 11)

By making several assumptions about which vehicle body types are associated with construction and other industries, and by examining the types of goods moved in London and in the country as a whole by freight vehicles (and again making assumptions about the industries with which these goods may be associated), the analysis of exposure data suggests that in London the construction industry is responsible for a greater proportion of the exposure to risk to cyclists than it accounts for nationally.

When fatal collisions with cyclists involving HGVs in London are considered, it can be seen that rigid vehicles (which are more likely to be associated with construction than are articulated vehicles) make up 89% of the fatalities from 75% of the distance travelled; articulated vehicles are responsible for 11% of the fatalities from 25% of the distance driven. When the freight task is also considered this analysis becomes much more stark, with rigid vehicles involved in 89% of the fatalities but only 54% of the freight lifted (tonnes) or 27% of the freight moved (tonne km); articulated vehicles are involved in 11% of the fatalities despite lifting approximately 46% of the freight (tonnes) or 73% of the freight moved (tonne km), on journeys to, from and within London.

It is likely that the differences in risk between rigid and articulated vehicles are associated with features of the routes they drive, the vehicles themselves, and the types of journey in which they are engaged; the current project will provide some initial findings on these issues, although more detailed research (including modelling of flow rates of cyclists and other vulnerable road users on routes used) would be required to answer this question conclusively.

8.2 Contractual and operational practices

Specific finding 1: There is a lack of ownership of road risk by clients and principal contractors in the construction industry (see recommendations 3, 4, 5 8 and 9)

There is limited ownership of road risk within the construction industry by clients and principal contractors. This stands in contrast to the ownership of health and safety risk on site. Based on the interview data, it is clear that the principal contractor tends to take responsibility for the health and safety of all workers on the site, but once a driver leaves the site, principal contractors commonly report that the driver's safety is no longer their responsibility. The client is generally not concerned (contractually) with the safety of drivers delivering to the construction site, and of other road users.

Several quotes from members of construction networks interviewed as part of the research illustrate this point. This suggests that the ownership of construction vehicle driver safety typically rests with their employer (who may be a subcontractor or the driver himself in the case of owner-drivers). In contrast, the interviews conducted with individuals who worked, or have previously worked in general haulage suggest that a haulage driver working for a large delivery company will be working directly for the client, who will have a vested interest in the driver's safety, and that of cyclists.

Construction Network 3 provides a counter-example to this finding and to general finding 1; in this case the client and principal contractor appear, generally, to take ownership of driver health and safety including off-site driving, in both their health and safety policies, their consideration of who to contract, and their reporting. It should be noted however that Construction Site 3 is not without fault in its treatment of road risk as equal to more general health and safety risk – see specific finding 2.

Specific finding 2: Data on collisions and near misses on the road are not generally collected on construction projects (see recommendations 1, 3, 4 and 5)

Statistics relating to on-road collisions are usually excluded from an organisation's overall safety statistics. These are often inspected during contractor procurement, but the key concern is on-site collisions. Driver safety, particularly off-site, does not generally appear to be considered.

Again, Construction Network 3 provides the counter example by demonstrating good practice. It is worthy of note however that even in this network, some confusion existed about reporting of road incidents. For example the principal subcontractor on one site within the Network, when questioned whether road collisions would be reported through the site health and safety reporting, stated that *"it's in the roads, it's nothing to do with the site"*.

Clearly even within the exemplar 'good practice' network, although the culture is that on-road incidents are reported, practice is not perfectly aligned with this expectation; this is more evidence that road risk is being treated differently to on-site risk.

Specific finding 3: There may be a lack of awareness about road risk in the construction industry (see recommendations 1, 2, 3, 4, 5 and 9)

Another key finding is that despite the wide publicity that the issue of cyclist collisions with large vehicles has received, the levels of awareness of the issue in construction industry in London appear to be low.

Specific finding 4: The Fleet Operator Recognition Scheme (FORS), and Construction Logistics Plans (CLPs), are existing mechanisms that might be used to manage road risk in the construction industry; however they are not used as widely or as seriously as might be hoped (see recommendations 5 and 9)

There are two existing mechanisms by which road risk might be managed in the construction industry; these are FORS and CLPs. Some evidence was found in the research that although these are used, there are shortcomings in *how* they are used and monitored, and (in the case of CLPS) how widely they are used. For example with FORS, some evidence was found of organisations gaining membership to secure contracts, but subsequently not taking an active interest in FORS and its requirements and guidance. In addition, there was a suggestion from one client that monitoring of the scheme is something for which there is insufficient time.

In terms of CLPs, it was found that there are few examples of them being used within the London area, outside of Croydon and TfL-led contracts. There is generic guidance in place and freely available (TfL's document 'Building a better future for freight: construction logistics plans'). However, this guidance takes a higher level approach,

explaining the needs, benefits and features of CLPs without providing a definitive template for planners and developers to utilise. The Croydon series of publications provide both an explanation of CLPs and a working template, with instructions for developers. These documents were being finalised at the time of the research. Croydon is in the process of making the production of CLPs a requirement of planning.

The guidance documents that were examined, and some CLPs that were scrutinised, make reference to road safety and the importance of routing and site access with respect to traffic flows and vulnerable road users. However, with the exception of TfL-specified conditions of contract (including Crossrail) no reference is made of the need to ensure that cyclist safety is specifically addressed in terms of contractual obligation, driver training or vehicle specification. This is an area where action is recommended through the development of a pan London CLP template – for planners and developers – that includes cyclist safety as a key road safety feature.

Specific finding 5: Delivery time slots used in the construction industry may contribute to driver pressure (see recommendations 5 and 8)

Many construction sites utilise a delivery booking system to manage arrivals to the site, whereby vehicles are assigned a time slot in which to arrive. Although one respondent reported that there was no expectation of meeting time slots, there was widespread evidence of an awareness that this can place pressure on drivers, particularly when the time slot is tight (e.g. if they have a 15 minute window in which to arrive) or when the construction site has a policy of refusing any early or late deliveries.

Specific finding 6: Route planning to avoid interactions with cyclists is especially difficult on construction projects due to the transitory nature of sites (see recommendations 5 and 9)

The transitory nature of construction sites makes route planning to avoid interactions with cyclists (the best way of avoiding collisions) challenging. Clearly this finding makes it even more important that CLPs are used properly.

Specific finding 7: Evidence suggests that pay per load does happen in the construction industry, however no evidence was found to suggest that it is a crucial factor in collisions with cyclists (see recommendation 10)

It is clear that pay per load contract arrangements do exist within the construction industry; however many of the organisations in all of the supply chains used employed drivers who were paid an hourly or annual wage. Some companies (usually further down the supply chain than the principal contractor) either use owner drivers or small businesses to supplement their employed staff when necessary, and these individuals or organisations would be paid by the load. Other companies only used self-employed drivers in their work. The driver would own and maintain the vehicle, which would often display the umbrella company's livery. These drivers may also be paid per load delivered (based on delivery time, distance, load carried or a combination of the three). No specific evidence was found however that paying drivers in this manner changes the amount of work drivers attempt to do, or the time in which they attempt to complete the work

8.3 Drivers and vehicles

Specific finding 8: Although total blind spots are likely to be rare, visibility of cyclists in some areas around construction vehicles is still poor (see recommendations 6 and 7)

The main finding from the vehicle scanning task was that the view afforded of cyclists in some positions to the left and in front of the vehicle, even with mirrors fitted to meet legal requirements and positioned by a fully qualified driver, can be poor. Several analyses illustrate this general point.

Firstly we can consider what happens when the areas of the ground visible either directly or indirectly for the three vehicles scanned were compared, considering the 4m to the nearside of each vehicle (to reflect the lorry being in lane two with a 3.5 wide lane to its left) and approximately 9m in front. Figure 33 illustrates this comparison.

The visible area in direct view through the windscreen in this assessment was found to be greatest in the MAN curtain side lorry. The design of the vehicle dashboard and size of the windscreen contributes to the view available through the windscreen. The MAN curtain side lorry is the newest of the three vehicles assessed and thus it is possible that it has benefitted from design improvements to increase the visible area.

Comparing the 'grey' areas in Figure 33, it can be seen that the area not directly or indirectly visible (at ground level) to the DAF Mixer (21m²) is 50% greater than the area not directly or indirectly visible to the MAN curtain side (14m²). The visible area in direct view through the windscreen in this assessment was found to be greatest in the MAN curtain side lorry. The design of the vehicle dashboard and size of the windscreen contributes to the view available through the windscreen. The MAN curtain side lorry is the newest of the three vehicles assessed and thus it is possible that it has benefitted from design improvements to increase the visible area. The DAF Tipper is the vehicle which provides the least visible ground zone for the assessed area through the windscreen. One potential explanation for this is the height of the driver with respect to the ground. The driver's eye point for the DAF Tipper is higher than that of the DAF Mixer and MAN Curtain side, consequently for the same height driver and similar shaped dashboard the first point at which the driver will be able to see the ground in front of the vehicle in the DAF Tipper will be further away.

On the DAF Mixer vehicle tested, the forward projection mirror (designed to give an indirect view in front of the vehicle) was retrofitted inside the cab. This resulted in there being a true blind spot large enough for a 1.22m tall cylinder 0.3m in diameter to be hidden completely from view in the forward projection mirror from the driver's normal eye position if placed directly in front of the lorry. This is illustrated in Figure 19.

A third analysis was the examination of the 3D models of the visibility of cyclists (modelled as 1.5m tall) in different positions to the left of and in front of the vehicle. The analysis showed that in all vehicles, there were positions in which cyclists could barely be seen from a static viewing position at the driver's eye level. For example in the DAF Tipper, only a tiny proportion of the cyclist in position 9 could be seen through the windscreen (a small proportion would also be visible in the forward projection and side close proximity mirrors).

In fact for all the vehicles scanned, between positions 5 and 12 inclusive, none of the vehicles would provide the driver with a complete view of the 1.5m tall cyclist. This is not unexpected following the assessments of ground level views, due to the fact that

these positions lie within the regions where the ground is not always visible to the driver. Table 28 shows whether a 1.5m cyclist would be wholly or partially visible for each viewing component of the three lorries assessed.

When considering these findings, it needs to be remembered that the small sample of vehicles tested makes it difficult to generalise the findings to all construction vehicles. However the results can be taken as indicative of areas that warrant further investigation. In particular, the effect of vehicle height on direct lines of visibility (as with the tipper in this study) might be something that is worthy of further specific study, since this might be something that can be improved over the medium to long term through working with vehicle manufacturers. In addition, the finding of a true blind spot in front of the mixer lorry (arising from the positioning of the retrofitted front projection mirror) illustrates that technological solutions are not a guaranteed solution if the way in which they are fitted and used is not considered¹².

Specific finding 9: There is great potential for driver error and high driver workload in construction industry driving, and multiple changes will be needed to reduce this (see recommendations 4 to 10)

The cognitive task analysis revealed a number of points of possible failure, most of which are associated with a breakdown in visual awareness, and many of which may take place before the driver and cyclist arrive at a junction. The analysis suggested that only checking mirrors having reached the junction, or even on the immediate approach, is a risky strategy. The vehicle scans show that although there are few true blind spots on the vehicles assessed, the whole cyclist is rarely visible and, depending on their location, they may be barely visible. This makes cyclists difficult to spot, and even if drivers do see certain visual indications, it is not necessarily easy to recognise what is seen as being a cyclist or a hazard.

To achieve a high level of awareness of what is behind or beside the vehicle drivers must check their mirrors frequently. This usually results in them seeing a scene that is slightly different each time they view it, and piecing together the evidence to form, and continuously update, a mental representation of the world. This process is described in the following figure which shows a basic cyclical model of human action (Hollnagel, 2005).

The difficulty with this strategy is that vision is a constrained resource, which is in high demand while driving. It is not physically possible to fixate on all aspects of the road ahead simultaneously, let alone the instruments and the mirrors as well. Awareness is achieved by scanning different parts of the environment in turn. This mechanism is not perfect, as it is possible that key hazards will be missed when visual attention happens to be allocated elsewhere. Thus, although mirrors on large vehicles will be part of the solution to avoid blind spots, they are not the total solution; consideration needs to be given to how many sources of information drivers can realistically monitor, and to reducing other factors that will increase demand on visual attention.

¹² One possible mitigation against vehicle mirrors not being correctly fitted is the use of blindspot (Trixi) mirrors at junctions. However little is known about how these mirrors are used by drivers, and as with the conclusions drawn from the observed drives it is possible that additional sources of information will not always be used optimally by drivers with other pressures on their mental workload.

A very broad range of factors can affect the likelihood of the driver errors that have been identified. These factors relate to the vehicle, the driving environment, the cyclist, the driver or the driver's organisation. Examples include:

- Driving to unfamiliar site locations – this is likely to lead to high demand, and a paucity of mental resource to allocate to visual attention or a reduction in normal road scanning behaviour.
- Narrow roads and tight corners – this is again likely to require considerable attention (specifically visual attention) from the driver, and again will lower the resource available to maintain awareness of hazards.
- Cyclists' behaviour not conforming to usual expectations – goal-directed looking behaviour dominates in skilled tasks such as driving, and a large part of this is led by expectation. This study has not attempted to describe what these drivers' expectations about cyclists are, but their comments on cyclist behaviour may hint at some scenarios where their expectations are violated. It is likely that several factors are involved. For example, drivers mentioned some cyclists not following a defined path and attempting to undertake vehicles indicating to turn left. The variability in manoeuvres and freedom of movement that cyclists enjoy (for example due to their small size) means that some drivers' expectations of typical cyclist behaviour will be less reliable. If cyclists do not conform to expectations, then some drivers may fail to detect them if they look in places they expect to see cyclists, rather than where the cyclists actually are. Another factor relates to the frequency with which some construction vehicle drivers will encounter cyclists in their usual driving. Even with the high cyclist numbers seen in London, it is important to note that for a given journey undertaken by a construction vehicle driver (especially if the journey originated outside of London), cars will be encountered much more frequently than cyclists; thus the expectations of some drivers will be predominantly shaped by their encounters with cars, and this again makes their expectations with regards to cyclist behaviour less reliable.
- Time pressure (delivery time slots) – it is well known that there are time/error trade-offs in skilled tasks like driving. If drivers are trying to attain a given time schedule this is likely to result in more errors.

The analysis shows that there is unlikely to be one single 'human error' cause of vehicle collisions with cyclists during turning manoeuvres; rather, a range of factors exist and would need to be considered in addressing the problem. Possible solutions are given in Chapter 4, but it is clear that a holistic approach would need to be taken in applying them. For example, consideration would need to be given to the effects on the driver of any modifications to vehicles or company procedures, as solutions that result in an increase in workload or time pressure could ultimately have a detrimental effect on safety.

9 Recommendations

The recommendations associated with the findings described in Section 8 are organised under four headings; 'Raising the profile of work-related road safety', 'Improving work-related road safety management in the construction industry', 'Making construction vehicles and journeys safer', and 'Data improvements'. In addition, a final recommendation is given relating to the ownership of recommendations one to 11.

9.1 Raising the profile of work-related road safety

The first general finding of the current research was that road risk is frequently viewed as less important than general health and safety risk by construction organisations. In order to improve the safety of cyclists in relation to construction vehicles, it is necessary to tackle this issue as part of ongoing improvements to WRRS, which are actually applicable to all organisations (even those outside of construction).

Recommendation 1: HSE should extend the Reporting of Injuries, Diseases and Dangerous Occurrences Regulations (RIDDOR) to include on-road collisions

Currently, work-related road collisions are not reportable to HSE, whereas on-site accidents resulting in seven or more days of absence, or a serious injury, are reportable under RIDDOR (HSE, 2012). To improve the perceived importance of work-related road risk, HSE must extend RIDDOR to include on-road collisions involving individuals driving for work. We recommend that the HSE should extend RIDDOR to include on-road collisions as a matter of urgency. To improve the likely success of such a campaign, the Metropolitan Police Service, traffic commissioners, VOSA and other interested stakeholders should be involved.

It is likely that changes to RIDDOR of this magnitude will take a considerable amount of time to implement. In the shorter term, HSE could develop an Approved Code of Practice (ACoP) for work-related road safety (including the requirement to record on-road collisions), for use by all industry sectors, including the construction industry.

Recommendation 2: Adherence to a nationally recognised standard on work-related road safety (such as the ISO39001 standard on road traffic safety management) should be promoted

A new International Standard has recently been issued (ISO39001:2012). This specifies requirements for a road traffic safety management system, to reduce fatalities and serious injuries related to road traffic collisions. Organisations of five or more employees driving to or from construction sites within London should be required to achieve this standard¹³, or a similar standard as determined by the industry. Consideration should be given as to how this standard would apply to companies of different sizes; the time and

¹³ Note that recently published research for the Metropolitan Police Service (Helman, Buttress & Hutchins, 2012) has suggested that ISO39001 might require support from a simple guidance document, ideally in the form of an HSE Approved Code of Practice regarding those risk factors that should be the focus of any interventions used within the wider management of road risk. Helman et al. also suggest that a standalone national standard could be developed in place of ISO39001, based on the TfL FORS template.

cost of achieving an ISO or similar standard for smaller organisations may be prohibitive; therefore we recommend that based on the ISO39001 standard (or equivalent national standard – see footnote below), and the HSE Driving for Work Toolkit (INDG382), a checklist should be developed for any client or contractor subcontracting to small businesses, to ensure that they also adhere to recommended practice. TfL should extend CLP guidelines to support these activities.

9.2 Improving work-related road safety management in the construction industry

There is potentially a lack of awareness within the construction industry of road risk, and also lack of ownership and management of the risk. It is therefore necessary to firstly raise awareness within the industry of both the risks and how to manage them, and then to put in place mechanisms to support organisations to manage road risk and functions to ensure this is achieved.

Recommendation 3: HSE should include off-site safety in the Construction Phase Plan (mandatory under the CDM regulations)

Organisations are not required to report on-road collisions to the HSE. In addition, the CDM (construction design and management) regulations governing the construction industry do not require driving for work to be included in the construction phase plan; the construction phase plan is a requirement for all notifiable construction projects, and outlines the arrangements for managing health and safety during construction work. Currently this only covers on-site health and safety. TfL should further lobby HSE to make inclusion of off-site safety (i.e. driving for work) in the construction phase plan mandatory. Under the CDM regulations the principal contractor takes ownership of the construction phase plan and therefore, if it is included, ownership of off-road risk.

Recommendation 4: Existing channels should be utilised more effectively to raise awareness of road risk within the construction industry

The importance of managing construction vehicle safety once the vehicle has left the construction site needs to be communicated within the construction industry, and guidance should be produced to assist with this. Content should include discussion of the extent to which cyclists are visible in different areas around the vehicle, highlighting the fact that mirror coverage does not mean cyclists will always be detected. It could also include awareness raising around the variability in cyclists' behaviour (see specific finding 9). The FORS network should be used to communicate these messages to the construction industry by the use of newsletters etc., however this may only influence those who already have some interest or involvement in road safety.

There are many associations within the transport sector, such as the Construction Equipment Association, the Construction Industry Council and the Mineral Products Association, who should use their networks to more widely promote road risk as a key topic. Events such as conferences, seminars and workshops would also be a valuable tool in improving knowledge of the issue and measures to improve road safety for construction vehicle drivers. These could be organised via Brake/ROSPA/FORS/Roadsafe etc.

Recommendation 5: CLP guidance should be updated by TfL and its use promoted throughout London. CLP compliance should be monitored by TfL. This should be embedded into the planning application process for London-based construction projects

There needs to be a standard to which all organisations operating in the construction industry within London adhere. Updated CLP guidance which is used by all London boroughs for public and private construction work should be used for this.

The CLP guidance should be updated to make it more robust as a mechanism for ensuring each construction site has a means of managing road risk. Current CLPs should be updated to include topics such as ISO39001 and data reporting/recording of on-road collisions. Additionally, CLPs should require that once organisations have met the required standards, they are audited to ensure that they continue to meet these standards throughout the life of the project.

Other public bodies, especially Local Authorities, should be involved to ensure that CLPs are used for all public construction projects let in London, supporting Local Authorities in putting processes in place for their inclusion and management. Furthermore, working with Local Authorities, CLPs should be used for all construction projects in London, with Local Authorities having a role to play in implementing and monitoring compliance for all construction projects undertaken in their borough.

9.3 Making construction vehicles and journeys safer

Although total blind spots seem likely to be rare based on the small number of vehicles scanned in the current project, visibility of cyclists in some areas around construction vehicles still has the potential to be poor. From the task analyses carried out it is clear that there is great potential for driver error and high mental workload in construction industry driving, and multiple changes will be needed to reduce this.

9.4 Making construction vehicles and journeys safer

Recommendation 6: Vehicle manufacturers should work to improve vehicle and mirror design

Of the vehicles examined, some had a much larger non-visible area (at ground level) than others; various aspects of vehicle design can be addressed to improve drivers' view of cyclists, and vehicle manufacturers should seek to identify and implement design improvements that might be made specifically for vehicles driving on London's streets. This could include changes to windscreen or dashboard design, as well as new technologies and improved mirror design. For example, the driving position in one of the construction vehicles studied in this research was higher off the ground, which may have resulted in an increased area directly through the side windows and windscreen that was not visible to the driver. Front and side windows which extend lower (towards the ground) would increase direct visibility to the front and side of these vehicles.

In relation to mirrors, the convex side close proximity mirror covers a wider area than an equivalent non-convex mirror, but the object in the view can become distorted. Further research is needed to ascertain which combination is preferable (i.e. a larger visible area with a distorted view, or a smaller area with a non-distorted view) and relevant bodies, e.g. the European Union, should be engaged with regarding approvals. Any technology

that has a safety benefit, which is included in new vehicle design, should be retrofitted to existing vehicles where possible.

It is important that the introduction or modification of mirrors (or mirror configurations and combinations) does not result in an increase in driver workload; the best combination of mirrors needs to be identified which enables optimal visibility *and* workload. We understand that effecting industry-wide change in the longer term is likely to require changes to relevant directives. However in the short to medium term it will be useful to engage vehicle manufacturers in defining innovations and improvements that might be adopted specifically for London (see, for example, the development of the new 'Bus for London', TfL, 2012b).

Recommendation 7: A wider review of the blind spots in different construction vehicle types should be conducted

A wider, comprehensive review of vehicle blind spots and the challenges faced by drivers should be commissioned, using a broader range of vehicles and mirror configurations. The current research considered three vehicles of differing ages and produced by different manufacturers, and therefore was not representative of the range of tippers, mixers and curtain side vehicles available. A comprehensive review of vehicles used in the construction industry would greatly improve understanding of the extent to which mirrors afford drivers with views of cyclists in key risk areas around construction and goods vehicles, and would help to identify human factors issues associated with their use. The outcome of such a review would be a business case to use in demonstrating the need for regulatory change in the UK or EU.

Recommendation 8: Principal contractors and clients should use more realistic delivery time slots

Whilst the obvious measure to reduce driver pressure relating to meeting delivery time slots would be to eliminate them altogether, this would result in unnecessary pressures on-site (e.g. multiple concurrent deliveries requiring unloading) and vehicles queuing on local roads, causing other issues. An alternative is the use of more realistic time slots, for example by allowing vehicles arriving either side of their allocated slot to enter the site where reasonable, or the use of holding bays to facilitate early arrival. Management should aim to record how frequently vehicles arrive outside of their allocated delivery slot, and to understand why they are arriving to site earlier or later than expected. This will enable any site-specific issues to be addressed, along with continual improvement of the delivery booking system.

CLPs should include consideration of how deliveries take place (e.g. length of time slot, use of holding bays in which vehicles can wait in a safe location before delivering to the site). The CLP audit should include a review of the effectiveness of any processes implemented.

Recommendation 9: CLPs should include the definition of safer routes to construction sites

As part of the mandatory CLPs, principal contractors should define safer routes to their site (within a set local radius, for example five miles), where possible avoiding risky areas such as schools, cyclist 'hotspots', narrow roads and difficult junctions, and in all

cases attempting to minimise exposure to vulnerable road users. Such changes would help to address the potential problem of drivers being under greater cognitive workload in the vicinity of construction sites than they are used to in their usual driving. Principal contractors should also ensure that all drivers operating on their site are happy with the routes and understand the importance of using only the prescribed routes. Drivers should be encouraged to feed back to the principal contractor on the usability of the routes. A way to support this could be through TfL's Freight Journey Planner. On routes where high cognitive workload is unavoidable, extra training and other extra safety precautions should be considered.

In addition local authorities, when reviewing planning applications, could make CLP use a requirement for notifiable construction projects.

Recommendation 10: Further research should be conducted to understand the effects of pay per load contracts

There is a perceived risk that pay per load contracts encourage drivers to achieve a greater number of deliveries than can reasonably be expected of a safe driver. However no definitive evidence emerged in the current research to support this. Most instances of pay per load that were identified in the current research involved owner-drivers, and the removal of pay per load may be an unwelcome change which would greatly affect the industry's status quo, and therefore would need to be supported by a substantial body of evidence. Therefore at this stage, instead of eliminating pay per load, the umbrella organisation using these owner-drivers could be held responsible for their health and safety, including the hours they drive. However, this is an area in which further research is required in order to gain a better understanding of the use of pay per load and any impacts it has on driver behaviour.

9.5 Data improvements

Although road casualty statistics make it difficult to identify industry sectors associated with collisions, the evidence did suggest that construction traffic is over-represented in collisions with cyclists in London. A single recommendation is offered here to help address the data problem within national casualty statistics.

Recommendation 11: The vehicle type 'construction vehicle' should be included in Stats19

The addition of a 'construction vehicle' category or other means of recording the involvement of vehicles used for construction on the Stats19 form is recommended. This would improve knowledge of the prevalence of collisions between cyclists (and other vulnerable road users) and vehicles used for construction.

DfT frequently hold a consultation to review and update the Stats19 form, although the review cycle is believed to currently be five to six years, with the latest changes made in 2011 (meaning that the changes would not be expected in the data until 2016-2017 on the regular cycle). The next Stats19 consultation should be responded to, with the suggestion of additional 'vehicle type' categories to enable identification of vehicles used

for construction purposes. If a shorter timeframe is desired, the Metropolitan Police Service should be involved to see if changes can be made more quickly¹⁴.

9.6 Ownership of recommendations

Recommendation 12: Recommendations 1 to 11 need to be acted on by stakeholders from across the industry, working with relevant regulatory bodies when necessary

Where possible, the ownership of the previous recommendations must lie with the relevant industry stakeholders, including regulators, the construction industry, and vehicle manufacturers. Without clear ownership there is a risk that the recommendations will not be addressed; the identification and engagement of relevant key stakeholders is crucial to ensure that the recommendations are taken forward and acted on appropriately.

9.7 Limitations, and general considerations for future research

All research methods have their limitations. The current research has identified a number of issues using largely qualitative research techniques; the research considered specific examples in depth rather than 'surveying' the industry as a whole. For example the vehicle scanning considered only three vehicles used in the construction industry (and only one mirror configuration in each). Another example is the small sample of construction networks involved in the interviews; the responses given are unlikely to fully represent opinions across the industry as a whole, and it is not possible to generalise the findings in quantitative terms. For example, although one of the three networks accessed showed relatively good practice, this network was chosen specifically to represent an exemplar of what could be achieved when focused attention is placed on vulnerable road user safety in contracting and working practices; therefore we would not conclude from these results the proportion of construction sites that we would expect to show good or poor practice. The true value of the findings is in identifying specific issues that deserve further investigation using more quantitative techniques on larger samples, and (in combination with other findings from the literature) in identifying high-level, strategic findings that can act as catalysts for change. Many of these are represented in the recommendations described in this section.

One additional general finding that has yet not been discussed in detail is the lack (before this project) of any research into the specific issue of construction traffic and cyclist risk. Some of the recommendations given above will require such research; for example recommendation 7 is likely to require some wider quantitative research into the prevalence of different vehicle heights, dashboard and windscreen designs on construction vehicles to understand if the lower levels of direct sighting through the windscreen seen on the Tipper vehicle in this study is indicative of a wider problem. Another example of further research that may be valuable is a survey of a wide range of construction and general logistics companies to establish how widespread the practice of pay per load is, and at what level of networks it is used.

¹⁴ There is a precedent for quick turnaround of changes to Stats19 data collection, when contributory factors were trialled and introduced in the 1990s. This is described in Broughton, Markey and Rowe (1998).

A final point is that it is important that the effectiveness of any measures implemented to improve the safety of cyclists in relation to construction vehicles is well understood. A benchmarking exercise is recommended in order to support understanding of which measures have the greatest impact. Due to the low absolute number of KSI collisions involving cyclists and construction vehicles each year, any impact of implemented measures would not be discernible using Stats19 data only, and therefore proxy measures to support this analysis (for example observations of near misses) should be considered.

References

Annett, J. & Duncan, K. D. (1967) Task analysis and training design, *Occupational Psychology*, 41, 211-221.

Brake (2006). *Managing agency drivers*. Available from: <http://exchange.brake.org.uk/Sites/brake/downloads/Man%20Agency%20Drivers%202006.pdf>

Cookson, R. & Knight, I. (2010). *Sideguards on heavy good vehicles: assessing the effects on pedal cyclists injured by trucks overtaking or turning left*. TRL Report PPR514. Crowthorne: Transport Research Laboratory.

DfT (2009). *Transport statistics bulletin: Road Freight Statistics 2008*. Department for transport, national statistics publication, London. Available from: <http://www.dft.gov.uk>

DfT (2011a). *Transport statistics bulletin: Road Freight Statistics 2010*. Department for transport, national statistics publication, London. Available from: <http://www.dft.gov.uk/statistics/releases/road-freight-statistics-2010>

DfT (2011b). *Vehicle licensing statistics 2010*. Department for Transport, national statistics publication, London. Available from: <http://www.dft.gov.uk/statistics/series/vehicle-licensing/>

DfT (2012). *Driver Certificate of Professional Competence (CPC) statistics*. Available from: <http://www.dft.gov.uk/publications/dsa-driver-cpc-statistics/>

Embrey, D.E. (1986). SHERPA: a systematic human error reduction and prediction approach. Paper presented at the *International Topical Meeting on Advances in Human Factors in Nuclear Power Systems*, Knoxville, Tennessee.

FTA (2011). *FTA Cycling Code*. Available from: http://www.fta.co.uk/export/sites/fta/galleries/downloads/cycling/fta_cycling_code.pdf

Helman, S., Delmonte, E., & Stannard, J. (2012). *Construction logistics and cyclist safety: summary report*. TRL Report RPN2356. Crowthorne: Transport Research Laboratory.

Helman, S., Buttress, S. & Hutchins, R. (2012). *A gap analysis of work-related road safety in the UK: working toward a national standard*. Published Project Report PPR626. Crowthorne: Transport Research Laboratory

Hollnagel, E. (2005). Contextual control model, *University of Linköping* [online]. Accessed 21 August 2012. Available from: http://www.ida.liu.se/~eriho/COCOM_M.htm

HSE (n.d.) *Delivering Safely*. Available from: <http://www.hse.gov.uk/workplacetransport/information/cooperation.htm>

JAUPT (2011). *Driver CPC: A guide to periodic training*. Available from: [http://assets.dft.gov.uk/dsa-bl/guide to periodic training.pdf](http://assets.dft.gov.uk/dsa-bl/guide%20to%20periodic%20training.pdf)

Keigan, M., Cuerden, R. & Wheeler, A. (2009). *Analysis of police collision files for pedal cyclist fatalities in London, 2001-2006*. TRL report PPR438. Crowthorne: Transport Research Laboratory.

Knight, I., Minton, R., Massie, P., Smith, T. & Gard, R. (2006). SO211/VE Heavy Vehicle Crash Injury Study, HVCIS. TRL report PPR096. Crowthorne: Transport Research Laboratory.

Knight, I. (2011). *A study of the implementation of Directive 2007/38/EC on the retrofitting of blind spot mirrors to HGVs*. TRL Report PPR588. Crowthorne: Transport Research Laboratory.

Palmer, M., Walter, L. & Keigan, M. (2011). *On-road trials of roadside mirrors in London*. TRL Report CPR986. Crowthorne: Transport Research Laboratory.

Pew, R.W., Miller, D.C. & Feehrer, C.G. (1987). *Evaluation of proposed control room improvements thought analysis of critical operator decisions*. (Palo Alto, CA: Electric Power Research Institute).

Risser, R. & Brandstätter, C. (1985). *Die Wiener Fahrprobe*, Wien: Kleine Fachbuchreihe des Kuratoriums für Verkehrssicherheit, Band 21.

RoSPA (2011). *What are the most common causes of road accidents?* Available from: <http://www.rospa.com/faqs/detail.aspx?faq=298>

Schoon, C.C. (2006). *The problems of lorries turning right: an analysis based on crashes in 2003 and the new EU guidelines beginning in 2007* (English language summary) SWOV Report R-2006-2, The Netherlands.

Smith, T.L. & Gard, R. (2002). *A review of accidents involving agricultural and other types of working vehicle, 1996 to 2001*. TRL project report PR/SE/443/02 Crowthorne: Transport Research Laboratory.

Swain, A.D. & Guttman, H.E. (1983). *A handbook of human reliability analysis with emphasis on nuclear power plant applications*, Nureg/CR1278, Washington D.C: USNRC.

SWOV (2009a). *Blind spot crashes*. SWOV Fact Sheet, The Netherlands.

SWOV (2009b). *Cyclists*. SWOV Fact Sheet, The Netherlands.

TfL (2007). *London Freight Plan. Sustainable Freight Distribution: A Plan for London*. Available from: <http://www.tfl.gov.uk/microsites/freight/documents/London-Freight-Plan.pdf>

TfL (2010). *Cycle Safety Action Plan*. Available from: <http://www.tfl.gov.uk/assets/downloads/corporate/Cycling/Cycle-Safety-Action-Plan.pdf>

TfL (2011a). *Travel in London, report 3* [Excel file]. Available from: <http://www.tfl.gov.uk>

TfL (2011b). *TfL Surface Transport Factsheet: Pedal cyclist collisions and casualties in Greater London*. Available from: <http://www.tfl.gov.uk/assets/downloads/pedal-cyclist-collisions-and-casualties-in-greater-london-sep-2011.pdf>

TfL (2011c). *Construction Logistic Operations and the Safety of Cyclists* (Bid Specification).

TfL (2012a). *TfL Surface Transport Factsheet: Casualties in Greater London during 2011*. Available from: <http://www.tfl.gov.uk/assets/downloads/corporate/casualties-in-greater-london-2011.pdf>

TfL (2012b). Designed for Londoners: Introducing London's latest landmark, the new bus for London. Available from: <http://www.tfl.gov.uk/assets/downloads/corporate/new-bus-leaflet.pdf>

Theeuwes, J. (1996). Visual Search at Intersections: An eye-movement analysis. *Vision in Vehicles*, 5, 125-134.

UoW (2011). *London Freight Data report 2010*. The University of Westminster, January 2011. Available from: <http://www.tfl.gov.uk/microsites/freight/documents/london-freight-data-report-2010.pdf>

Wickens, C. D. (1992). *Engineering psychology and human performance*, Second Edition, New York: HarperCollins Publishers Inc.

Appendix A Case studies

A.1 Case 1: Tipper truck

A.1.1 Driver and vehicle details

Driver		Vehicle	
Age	30-40 years	Type	Tipper
Years with HGV licence	16	Make/Model	DAF CF85.360
Years driving for the company	3 (2 of which as an agency driver)	Axles	4
Familiarity with the vehicle	Low – normally drives an articulated tipper	Tonnage	32T

A.1.1.1 Visibility from the vehicle

The vehicle was high off the ground, meaning that a driver could see above most other vehicles in traffic; however, their view of objects close to the driver's cab was limited. Objects could get close to the driver's cab on the nearside and offside, and also at the front of the vehicle, because the engine compartment was under the driver and did not protrude forwards. The tipper unit prevented rear vision from inside the cab. Thus, the size and shape limited visibility from the cab. In order to mitigate some of the visibility issues, the vehicle was equipped with two offside mirrors, four nearside mirrors and a CCTV system.

- Offside mirrors included one large wing mirror and a smaller blind spot mirror underneath.
- Nearside mirrors included the large wing mirror and smaller blind spot mirror (same as the offside mirror configuration), but these were also supplemented by a kerb mirror placed above the passenger door and a further mirror placed above the windscreen to the front of the vehicle, angled to show the ground directly in front of the vehicle.
- The CCTV system projected a rearward view from the back of the vehicle, onto a screen placed in the cab.

A detailed analysis of visibility from the vehicle is reported separately; however, during the observations it became apparent that even with continuous monitoring of all mirrors the driver may not be able to see approaching cyclists in some circumstances, such as:

- When the vehicle starts to turn a corner, the mirrors will also start to turn and cyclists previously visible near the rear of the vehicle will no longer be visible.
- Cyclists positioned slightly forward of the wing mirrors may not be visible to the driver.

A.1.1.2 Vehicle manoeuvrability

The driver of the vehicle can be considered an expert in manoeuvring it; however, the concentration required to drive the vehicle during rush hour traffic was apparent. At

times there was less than a six inch gap between the vehicle and kerb, and when cornering, the vehicle often crossed the lane markings due to roads being narrow. During the rush hour drive junctions were not always clear of standing traffic, and manoeuvring through them was challenging.

It was observed that because of the large turning circle of these vehicles, the path that they take through junctions is different to these taken by cars. For example, during left turns the driver initially steered towards the centre of the road, and then made a fairly sharp turn, ending up very close to the kerb.

A.1.1.3 Turn warning devices

When the left turn indicator was activated, a vocal warning was given outside the vehicle, advising road users that the vehicle was turning left.

In addition to the warning for other road users, an alarm was activated in the cab if sensors detected objects to the left of the vehicle that were within a pre-specified distance. The alarm was audio-visual, comprising a warning tone and a red light near the left hand wing mirror.

A.1.1.4 Driving style

The driver adopted a very cautious driving style. Speed was mostly constrained by traffic, but even where it was free flowing remained under the speed limit. Distance to vehicles in front varied but was appropriate. The driver monitored the mirrors very frequently, and especially during these types of manoeuvres:

- When slowing down or stopping
- When turning left or right
- When overtaking or making any lateral movements
- When the road width narrowed
- When restarting or speeding up.

All mirrors were checked before each left turn, and monitoring of the mirrors continued throughout the turn and upon completion of the turn.

When overtaking cyclists the driver moved away from the side of the road to give them space.

A.1.2 The first drive

A.1.2.1 The route and navigation

The drive took place in south/southeast London. The driver confirmed that he was familiar with the area but not the particular site the material was being delivered to. Along the route there were six roundabouts and ten junctions at an angle close to 90° at which a left or right turn was made. The round journey took approximately an hour and forty-five minutes, of which less than an hour and a half was spent driving on public roads.

The driver consulted a map book before leaving the depot. The map book then remained open on the dashboard throughout the journey, but was positioned away from the

driver, possibly to remove the temptation of engagement while driving. Having approached the destination the driver consulted the map once more while stopped at traffic lights.

Upon reaching the building site there was a little confusion about where the load was to be deposited, but this was resolved safely when the driver pulled over into a stopping bay, used his hazard warning lights, and exited the vehicle to find out where to go.

A.1.2.2 Driving conditions

The journey took place during daylight hours and visibility was good. The road surface was wet with some intermittent drizzle. The morning rush hour traffic was heavy and slow moving for the most part, and was affected by a collision on a nearby arterial route.

A.1.2.3 Driver workload and potential distractions

The driver was fairly talkative during conversations at the depot and on site; however, he remained silent throughout the drives. This is likely to reflect his level of concentration on the driving task.

The demands of different elements of the driving task were apparent when the vehicle in front abruptly stopped during a right turn at a traffic light controlled junction, when it had right of way. The tipper driver was checking the light was still green and monitoring his mirrors and had to brake sharply when he noticed the vehicle in front had inexplicably stopped. It is clear that people have a limited capacity to visually monitor their environment, and that no matter how much effort they put into monitoring their surroundings they cannot constantly maintain full awareness of all aspects of the situation.

It was noted that the vehicle was fitted with a telephone, which was not used during this drive. The driver's mobile phone rang once during the drive but he did not answer it.

It was noted that the process of depositing the load was not straightforward, and involved the driver waiting while an appropriate space was cleared for the materials. While the driver's schedule allowed for such delays, there is a possibility that with tighter schedules, the lack of organisation on customer sites could result in time pressure and, in turn, driving errors.

A.1.2.4 Driving errors and conflicts

Very few driving errors were noted. The driver did not indicate to come off a roundabout on one occasion. On two occasions it was very clear that the vehicle crossed the lane markings during a turn (one left and one right), although in both cases it the road was clearly too narrow to accommodate the turning vehicle.

Three conflicts occurred with other road users, neither of which were serious and neither of which were the fault of the tipper driver. These were:

- While approaching the back of a traffic queue a motorcycle undertook the tipper and pulled in front of it. It was clear that the driver had seen the motorcycle in the mirrors.
- A pedestrian stepped into the road causing the driver to brake and stop. The pedestrian then crossed the road when the driver waved her through.

- At a pelican crossing, a pedestrian stepped out into the road, and then back onto the pavement. The driver maintained a slow speed on the approach to the crossing.

A.1.2.5 Interaction with other road users

The following significant interactions took place between the driver of the tipper and other road users:

- A pedestrian stepped out into the road (at a crossing with traffic lights displaying a green aspect for vehicle traffic), causing the driver to brake. The pedestrian then stepped back onto the kerb.
- When a set of traffic lights turned green the driver did not move forward but looked into his mirrors, waiting for a cyclist and two motorcyclists alongside the vehicle to pass.
- When pulling away in heavy traffic, the driver waited for two motorcyclists and a cyclist that were overtaking the vehicle.
- When pulling away in heavy traffic the driver noticed a cyclist to the right of the vehicle and waited for it to pass before accelerating.
- The driver let a skip lorry into the traffic queue by flashing his lights.
- Before pulling away at traffic lights, the driver waited for four motorcycles to overtake and undertake before moving off.
- The driver gave way to a cyclist emerging from a junction by waving them on.

A.1.3 The second drive

A.1.3.1 The route and navigation

The drive started in southeast London and took a northerly route to cross the Thames and headed into the heart of west London, before returning along a slightly different route, through similar parts of the city. The driver confirmed that he was familiar with the area but not the particular site the material was being delivered to. The route required the driver to navigate ten roundabouts and 25 junctions at an angle close to 90° at which a left or right turn was made. The round journey took approximately two and a half hours, of which approximately two and a quarter were spent driving.

The method of navigation was very similar to the first drive; the driver consulted a map book before leaving the depot. The map book then remained open on the dashboard throughout the journey, but was positioned away from the driver. Then, having approached the destination, the driver consulted the map once more while stopped at traffic lights.

Upon reaching the building site there was once again a little confusion about where the load was to be deposited, but this was resolved safely when the driver pulled over into a stopping bay, used his hazard warning lights, and exited the vehicle to find out where to go.

A.1.3.2 Driving conditions

The journey took place during daylight hours and visibility was good. The road surface was wet from a previous rain shower. Although this journey started after the usual morning rush hour, the arterial roads used at the beginning of the drive were slow due to a previous collision.

A.1.3.3 Driver workload and potential distractions

Once again, the driver remained silent throughout most of the drive, probably reflecting his level of concentration on the driving task.

He did receive a phone call on the in-cab telephone, from a colleague advising of a change in the schedule. The phone call took place on a dual carriageway section of road while in motion. Although there may be operational benefits of communication between drivers and the depot it has been shown that use of a mobile phone, even handsfree, can distract from the driving task and lead to diminished driving performance.

During this part of the route it was very clear just how much attention the driver was paying to cyclists and motorcyclist, of which there were many.

The destination site was in a fairly busy location and streets were narrow with parked cars on either side. Searching for the site entrance or stopping space was therefore more challenging and added to the driver's workload.

Once again, having arrived at the site, the driver needed to wait while an appropriate space was cleared for the materials.

A.1.3.4 Driving errors and conflicts

Very few driving errors were noted. At one junction the lights turned amber in slow moving traffic when the driver had proceeded over the advance stop line. The driver stopped in the cyclist waiting area.

Eight conflicts occurred with other road users, none of which were the fault of the tipper driver. These were:

- A cyclist ahead of the vehicle swerved around a drain cover, causing the driver to slow down.
- A motorcycle drove perpendicular to the flow of traffic, between the tipper and the vehicle in front. This happened in slowly moving traffic and caused the tipper driver to brake.
- While moving through a junction, a motorcycle undertook the tipper and then pulled right in front of it, to overtake the vehicle in front, causing the driver to slow down.
- A bus to the left of the vehicle pulled ahead and then to the right, causing the driver to respond by steering right and slowing down.
- A cyclist pulled out of a junction ahead of the tipper, causing the driver to slow down.

- A taxi travelling in the opposite direction carried out a u-turn ahead of the tipper causing the tipper driver to brake.
- A cyclist approached a junction to join the main road at speed and did not appear to look for approaching traffic. Although the cyclist did eventually stop, the driver also braked, anticipating a conflict.
- A car in an adjacent lane swerved, causing the tipper to slow down.
- A motorcycle undertook the tipper when the driver was indicating to make a left turn.

A.1.4 Interaction with other road users

The following significant interactions took place between the driver of the tipper and other road users:

- The driver waited for two motorcycles to complete their overtaking manoeuvre before accelerating away at a red light.
- The driver stayed behind two cyclists who then proceeded to move to the centre of the lane in order to overtake parked cars.
- A cyclist approaching the vehicle from behind and to the left then moved behind the vehicle to overtake it. The tipper was indicating left.
- A taxi driver stopped at a green traffic light to pick up customers. The tipper driver made a verbal comment.

A.2 Case 2: Cement mixer

A.2.1 Driver and vehicle details

Driver		Vehicle	
Age	40-50 years	Type	Cement mixer
Years with HGV licence	18	Make/Model	DAF CF85.360
Years driving for the company	18	Axles	4
Familiarity with the vehicle	High – owns and operates the vehicle	Tonnage	32T

A.2.1.1 Visibility from the vehicle

The cab was almost identical to that of the tipper. The vehicle was high off the ground, allowing the driver to see above most other vehicles in traffic, but restricting the view of objects close to the cab. The mixer unit did not obstruct rear vision as much as the tipper unit; nevertheless, it was a significant obstruction. Thus, the size and shape of the vehicle meant that, without the aid of mirrors, visibility from the cab was limited.

Like the tipper, the cement mixer was equipped with two offside mirrors, four nearside mirrors and a CCTV system in order to improve visibility. In addition, it was equipped with a Fresnel Lens on the passenger window.

- Offside mirrors included one large wing mirror and a smaller blind spot mirror underneath.
- Nearside mirrors included the large wing mirrors and smaller blind spot mirror, but were also supplemented by a kerb mirror placed above the passenger door and a further mirror placed above the windscreen.
- The CCTV system projected a rearward view from the back of the vehicle, onto a screen placed in the cab.
- The Fresnel Lens on the passenger window gave a view of objects alongside the vehicle.

As discussed in Section A.1.1.1, even with continuous monitoring of all mirrors the driver may not be able to see approaching cyclists in some circumstances.

A.2.1.2 Vehicle manoeuvrability

The manoeuvrability of this vehicle was the same as that in Case 1. The driver did comment that liquid loads can behave differently to solid loads, and that this was a consideration during cornering and braking.

A.2.1.3 Turn warning devices

When the left turn indicator was activated, a vocal warning was given outside the vehicle, advising road users that the vehicle was turning left.

In addition to the warning for other road users, an alarm was activated in the cab if sensors detected objects to the left of the vehicle that were within a pre-specified distance. The alarm was only audible.

A.2.1.4 Driving style

This driver adopted a style that was defensive, but neither overly cautious nor aggressive. Throughout most of the drive there seemed to be some focus on keeping the vehicle going where possible, rather than coming to a stop. Driving speeds remained under the speed limit and distance to vehicles in front varied but was appropriate. The driver monitored the mirrors periodically, although not as much as the driver in Case 1. Monitoring of the mirrors was seen to increase:

- When slowing down or stopping
- When turning left or right
- When overtaking or making any lateral movements
- When restarting or speeding up.

A.2.2 The drive

A.2.2.1 The route and navigation

The drive took place in south/southeast London. The driver confirmed that he was familiar with the area and location of the site, and navigated based on his route knowledge without consulting a map. Along the route there were 18 roundabouts and two key junctions at an angle close to 90° at which a left or right turn was made. The

round journey took approximately an hour and a half, of which about forty-five minutes was spent driving on public roads.

Upon reaching the site there was a little confusion about where the load was to be deposited, but the driver was off public roads by this point and this was resolved safely when the driver asked a colleague where to go.

A.2.2.2 Driving conditions

The journey took place during daylight hours and visibility was good. The road surface was dry and traffic was free-flowing.

A.2.2.3 Driver workload and potential distractions

The driver remained in control of the vehicle throughout the journey. Workload during this particular drive would most likely to have been lower than in Case 1 because there was less traffic and in general the roads and junctions were wider. There were also fewer vulnerable road users.

On leaving the site the driver searched his pockets for his ticket (containing details of the delivery) as the vehicle was moving and soon found it. This did divert his attention away from driving, although it may be that the task of picking up the researcher at the site entrance disturbed the driver's normal routine, causing him to misplace the ticket.

The cab was not equipped with a car phone but the driver did have a mobile phone with a hands-free kit. The mobile phone did ring during the journey, but the driver cancelled the call. He then received a call and a text message from a voicemail facility, both of which were left unanswered.

A.2.2.4 Driving errors and conflicts

Driving errors noted included:

- Crossing the solid white line into a cycle lane.
- Not indicating to leave the roundabout on five occasions.

Two conflicts occurred with other road users:

- A vehicle pulled out onto a roundabout in front of the mixer. This was potentially serious, but not the fault of the mixer driver.
- On the approach to a roundabout, the cement mixer briefly drifted into the adjacent lane, even though there was sufficient space in the lane.

A.2.2.5 Interaction with other road users

No significant interactions were observed between the cement mixer and other road users.

A.3 Case 3: Curtain sider

A.3.1 Driver and vehicle details

Driver		Vehicle	
Age	50+ years	Type	Curtain sider
Years with HGV licence	4	Make/Model	MAN
Years driving for the company	1	Axles	
Familiarity with the vehicle	Usual vehicle	Tonnage	26

A.3.1.1 Visibility from the vehicle

Differences between this vehicle and the two construction vehicles in terms of visibility are discussed in full in section 0. However, in general, this vehicle had similar characteristics to the other two in that it was high off the ground, affording the driver a view over the top of most other vehicles in traffic, but limiting the view of objects close to the driver's cab. As with the construction vehicles, objects could get close to the driver's cab on the nearside and offside, and also at the front of the vehicle, because the engine compartment was under the driver and did not protrude forwards. Vision directly to the rear of the cab was blocked. In order to mitigate some of the visibility issues, the vehicle was equipped with three offside mirrors and four nearside mirrors. There was no CCTV system offering a view behind the vehicle.

- Offside mirrors included one large wing mirror, a smaller blind spot mirror underneath and a kerb mirror.
- Nearside mirrors included the large wing mirror and smaller blind spot mirror (same as the offside mirror configuration), but these were also supplemented by a kerb mirror placed above the passenger door and a further mirror placed above the windscreen to the front of the vehicle, angled to show the ground directly in front of the vehicle.

The observations confirmed that despite the presence of mirrors, in some circumstances cyclists approaching the vehicle may not be visible. One particular example observed was when the vehicle was on a roundabout; in this situation only objects that are close to the side of the vehicle can be seen. The issues here seem to be very similar to the construction vehicles, with the additional disbenefit of the lack of rear visibility.

A.3.1.2 Vehicle manoeuvrability

Although driven by a professional driver, the difficulties in manoeuvring the vehicle and the effort that this took were clear. Manoeuvres had to be planned ahead, especially in central locations where space was constrained. The vehicle often crossed the lane markings due to roads being narrow.

The vehicle had a large turning circle which meant that it needed to be steered right before taking sharp left turns.

A.3.1.3 Turn warning devices

This vehicle was not equipped with turn warning devices other than indicators.

A.3.1.4 Driving style

The driver adopted a cautious driving style. The posted speed limit was respected throughout, and large gaps were left between the vehicle and others ahead. Rather than squeeze through gaps in traffic the driver often waited for traffic to move. This may have been influenced by the fact that the driver was not on a delivery. Nevertheless, no signs of frustration were observed even when progress was very slow or other road users were causing conflicts. The driver did monitor the mirrors frequently, although not as frequently as Case 1. Mirrors were monitored during manoeuvres, but not as much when stopped at traffic lights. The monitoring of mirrors was heightened during these situations:

- When slowing down
- When turning left or right
- When overtaking or making any lateral movements
- When restarting or speeding up.

All mirrors were checked before each left turn, and monitoring of the mirrors continued throughout the turn.

When overtaking cyclists the driver moved away from the side of the road and often fully into the adjacent lane.

It was noted that the driver had a tendency not to choose the left hand lane if possible.

A.3.2 The drive

A.3.2.1 The route and navigation

The recorded journey took place in London, starting in the west of the city and ending in the east, with the vehicle remaining north of the Thames throughout.

A satellite navigation system was used. The system was manufactured by Garmin and was not a system specific to truckers. It did not issue warnings for low bridges or weight limits, nor did it take them into account during routing.

A.3.2.2 Driving conditions

The journey took place during daylight hours and visibility was good. The road surface was dry. The Friday afternoon traffic was building up; conditions were generally slow but kept moving.

A.3.2.3 Driver workload and potential distractions

The driver proceeded slowly and methodically along the route and it may have been the choice of speed that resulted in no outward signs of stress being exhibited.

One potential distraction was the satellite navigation system. The driver diverted around weight limits on two occasions, and each time the satellite navigation system issued distracting instructions to bring the vehicle back to the route originally planned.

When interviewed the driver estimated that less than a third of his journeys were to locations he was unfamiliar with. Driving on unfamiliar routes can be a stressful activity and satellite navigation systems giving instructions that are not correct for that size of vehicle could very easily divert attention away from the driver's navigation or vehicle control tasks. In such situations the distraction may be visual (where the driver is prompted to look away from the road and at the SatNav screen) or cognitive (where the driver is prompted to think about and evaluate SatNav instructions to the detriment of processing other information in the road environment). It is important to acknowledge that these criticisms are not directed at the SatNav itself; rather, at the incorrect choice of SatNav. When interviewed, the driver mentioned that his company did not supply these devices, and although SatNavs for trucks are available, that their price can be a barrier to purchase.

In addition to the cognitive and visual distraction posed by the SatNav, during the very first stages of the drive the driver manually interacted with the system.

No deliveries were made during the journey so it is not known whether tasks specific to this element of the driver's job would affect workload.

A.3.2.4 Driving errors and conflicts

Very few driving errors were noted. The driver did not indicate to come off a roundabout on one occasion and on at a different roundabout changed lane without checking mirrors (the layout of lanes was unusual so the driver may have thought he was keeping within his lane). During most left and right turns it was clear that the vehicle crossed the lane markings during a turn, although the road was clearly too narrow to accommodate the turning vehicle.

On one occasion (on a left turn immediately following a right turn) the driver used his indicator, but only allowed it to flash once. This may not have given other road users sufficient indication that the vehicle was turning left.

Seven conflicts occurred with other road users, of which four were considered serious in that they required sudden braking or had potentially serious consequences. One of these was the fault of the vehicle driver:

- Having gone around a large roundabout the driver was preoccupied with checking his mirrors (he later said he had been trying to work out where a bike was), and failed to notice in time that the traffic lights had turned red. He had to stop the vehicle abruptly when he did notice.

The remaining three serious conflicts were:

- A road user opened the door of a parked vehicle into the road, and the driver had to respond suddenly by braking, and then he changed lanes.
- The driver was approaching a roundabout slowly when a vehicle in the lane to the left suddenly moved in front, causing the driver to brake.
- A cyclist travelling in the opposite direction overtook a bus inappropriately and due to the carriageway width appeared to be on a collision course with the curtain sider. The driver was not travelling quickly and brought the vehicle to a stop to allow the cyclists to pass by safely.

Other conflicts included:

- Two cyclists and the vehicle were taking a turn to the right when the cyclists moved from the left side of the lane to the centre of the lane. The driver had already chosen to stay behind them throughout the manoeuvre.
- A cyclist overtook the vehicle and moved into the same lane just as traffic was moving off from a set of traffic lights.
- A pedestrian crossed the road against the traffic lights ahead of the vehicle.

A.3.2.5 Interaction with other road users

The following significant interactions took place between the driver and other road users:

- On several occasions, when a set of traffic lights turned green the driver did not move forward but looked into his mirrors, waiting for a cyclists or motorcyclists to move ahead.
- The driver chose to travel behind two cyclists for approximately half a mile as there were obstacles which would have made overtaking difficult.

A.4 Drivers' opinions

A.4.1 Encountering cyclists

All of the drivers said that they regularly encounter cyclists when driving in central London. Some routes were known to be more heavily used by cyclists than others. In addition, it was thought that more cyclists were on the road during the morning and evening rush hours than during the day.

For the two construction vehicle drivers, routes in London were an everyday occurrence whereas for the driver of the curtain sider they were not.

A.4.2 Opinions of visibility of cyclists from the vehicle

A.4.2.1 Cyclists behind the vehicle

Both of the construction vehicle drivers stated that as long as mirrors are used correctly then it is possible to see cyclists approaching the vehicle from behind. By constantly monitoring the mirrors they argued that cyclists can be seen some distance away and an awareness of their location maintained. One of the drivers said that he tended to use the rear view camera system to confirm the location of cyclists approaching from behind. The other driver highlighted the importance of having the mirrors set up correctly, and of cyclists remaining visible at night by wearing high visibility clothing and using appropriate lights.

A.4.2.2 Cyclists alongside the vehicle

Both of the construction vehicle drivers repeated the need for constant monitoring of mirrors to become aware of the presence of cyclists before they come alongside the vehicle. One driver mentioned that he preferred it if he could see cyclists in his large wing mirror (the image in it being bigger than other mirrors). He also mentioned that cyclists travelling wide of the vehicle were more difficult to see, as were cyclists travelling under the mirrors.

A.4.3 Opinions on what could affect the likelihood of a collision

All three drivers were asked for their opinions on why collisions take place between construction vehicles and cyclists. These factors were listed:

A.4.3.1 Vehicle factors

- Badly positioned mirrors may give a poor view of the area surround the vehicle, and may allow cyclists to go undetected by the driver.
- Large turning circles make the driver's intended manoeuvre difficult to interpret (e.g. pulling right before turning left).
- During manoeuvres, as the vehicle aligns with the centre of the road and then moves around the corner objects that were initially visible in the mirrors may no longer be seen, thus requiring the driver to make an assumption as to their location.
- The vehicles tend to proceed around corners slowly, giving other road users opportunities to gain on and crowd around the turning vehicle.
- If a cyclist is in front of the vehicle they can usually be seen, but once overtaken, it can be difficult to keep track of where they are.

A.4.3.2 Road layout factors

- Tight corners are difficult to take and require attention to correctly align the vehicle.
- On narrow roads it is difficult for cyclists and construction vehicles to move around one another.
- Fencing on bends gives rise to the possibility of cyclists getting crushed between the vehicle and fence.
- Roundabouts are risky as cyclists may not always be visible in the mirrors.

A.4.3.3 Cyclist behaviour

- Cyclists don't seem to follow a defined path, conform to rules or to expectations (they undertake or overtake, or follow unexpected trajectories).
- Cyclists can put themselves in danger by attempting to undertake, or pull alongside, a vehicle that is turning left. At times cyclists appear to ignore written warnings on the back of the vehicle, or audible warnings that the vehicle is turning.
- Cyclists might misinterpret the trajectory of large vehicles that are turning; they may enter the space between the vehicle and the kerb when the vehicle is moving right to turn left.
- A lack of awareness, by cyclists, of other road users may result in collisions.
- Cyclists may be motivated to keep moving as quickly as possible and thus may attempt to pass vehicles that appear to be cumbersome and slow.

A.4.3.4 Driver behaviour

- Poor visual awareness or use of mirrors may contribute to collisions.
- A lack of concentration may result in drivers not looking out for cyclists.
- If a driver happens to be looking somewhere else (because it is not possible to monitor everything all the time) they may fail to see cyclists.
- Drivers of large vehicles do sometimes get harassed, and poor behaviour on the part of other drivers (such as cutting in ahead of the vehicle) can cause drivers to become annoyed and make mistakes.
- It's easier to spot cyclists in areas where you expect them to be.

A.4.3.5 Organisational factors

- Some hire and reward systems encourage faster driving.
- Time pressure to complete scheduled jobs can lead to risk taking.
- Tiredness can lead to poor decisions (a 60 hour working week is normal).

Appendix B Task analysis for left turn manoeuvre

No	Task
1	Control speed (repeated task)
1.1	Perceive current speed
1.2	Compare speed to the situation
1.3	Adjust speed
2	Maintain awareness of driving situation (not necessarily done in order)
2.1	Monitor traffic through windscreen (repeated task)
2.1.1	Look ahead
2.1.2	Perceive elements through windscreen
2.1.3	Understand perceived elements
2.1.4	Determine whether elements are a hazard
2.1.5	Update mental model of situation
2.2	Check left hand mirror (repeated task)
2.2.1	Locate left hand mirror
2.2.2	Look in to left hand mirror
2.2.3	Perceive elements in mirror
2.2.4	Understand perceived elements
2.2.5	Determine whether elements are a hazard
2.2.6	Update mental model of situation
2.3	Check right hand mirror (repeated task)
2.3.1	Locate right hand mirror
2.3.2	Look in to right hand mirror
2.3.3	Perceive elements in mirror
2.3.4	Understand perceived elements
2.3.5	Determine whether elements are a hazard
2.3.6	Update mental model of situation
2.4	Check other mirrors (if available - repeated task)
2.4.1	Locate mirror
2.4.2	Look in mirror
2.4.3	Perceive elements in mirror
2.4.4	Understand perceived elements
2.4.5	Determine whether elements are a hazard
2.4.6	Update mental model of situation
3	Approach junction
3.1	Perceive junction
3.2	Compare junction with instructions or mental map
3.3	Assess junction layout
3.3.1	Determine road layout
3.3.2	Determine suitability for vehicle
3.4	Decide whether to turn at junction
If a decision is made not to turn at junction, return to 2.	
3.5	Develop a strategy
3.5.1	Determine alignment required to make turn
3.5.2	Determine route through junction
3.5.3	Determine appropriate approach speed
4	Check for hazards to the left of the vehicle
Do 2.2	
4.1	Determine whether elements will impact on left turn
If there are no elements that will impact on left turn, proceed to 5.	
4.2	Update strategy

4.2.1 Determine alignment required to make turn

4.2.2 Determine route through junction

4.2.3 Determine appropriate approach speed

Return to 4

5 Announce intention to turn left

5.1 Locate indicator

5.2 Activate indicator

6 Move over to the right

Do 2.3

6.1 Determine whether elements will impact on moving to the right

If there is not a hazard, proceed to 6.3.

6.2 Update strategy

6.2.1 Determine alignment required to make turn

6.2.2 Determine route through junction

6.2.3 Determine appropriate approach speed

Return to 6

6.3 Assess oncoming traffic flow

6.3.1 Look ahead

6.3.2 Perceive elements through windscreen

6.3.3 Understand perceived elements

6.3.4 Determine whether there is sufficient space to move over

If there is sufficient space, proceed to 6.4.

6.3.5 Update strategy

Return to 6.1.

6.4 Align vehicle in accordance with strategy

7 Turn left

Do 2.2

7.1 Determine whether elements will impact on left turn

If there are no elements that will impact on left turn, proceed to 7.4.

7.2 Update strategy

7.2.1 Determine alignment required to make turn

7.2.2 Determine route through junction

7.2.3 Determine appropriate approach speed

7.3 Assess traffic at junction

7.3.1 Look ahead

7.3.2 Perceive elements through windscreen and windows

7.3.3 Understand perceived elements

7.3.4 Determine whether there is sufficient space to make left turn

If there is sufficient space, proceed to 7.4.

7.3.2 Update strategy

Return to 7.1.

7.4 Steer vehicle in accordance with strategy

7.5 Check alignment of vehicle with road

If aligned, task ends.

7.6 Update strategy

Return to 7.4.

Appendix C Interview guide

Thank you very much for agreeing to talk to us about operational practices and safety culture. TRL is carrying out a study on behalf of TfL to identify safety issues relating to contractual and operational practices between construction developers and construction logistics operators. For all questions, please also consider your experiences in other organisations/ construction sites.

The interview should take about 20-25 minutes and we assure you that you will not be identified or identifiable in any publications resulting from this research. Your responses are completely confidential and will only be used for this research purpose. However, if there are any questions that you would rather not answer, please say so.

It would help enormously if I could record the interview. There will be nothing said by me to identify you on the recording. After the interview has been transcribed the file will be wiped clean. Do you agree for the interview to be recorded?

Background information

To begin, I'd like to get an understanding of you and your organisation:

- **What is the role of your organisation in the construction site - are you the client/ contractor/ subcontractor? Do you have subcontractors?**
- **How many people work in your organisation? How many sites/locations do you have?**
- **What is your specific job role within your organisation?**
- **How long have you worked in this industry?**
- **How long have you worked in this organisation?**
- **How long have you worked at this location?**

Selection

- **How is it done/who does it?**
- **What about driving at work? (on and off site)**
- **What about vulnerable road users like cyclists?**
- **If don't have subcontractors: Do you know how/why your organisation was selected?**

Prompts:

- Include drivers, owner-drivers, subcontractors
- Are the following considered: experience/skills/qualifications; H&S policies; H&S performance; driver licence checks?

Contracts

- **What is included in your contracts? [upward or downward]**
- **Do the contents differ based on who the contract is with? How?**
- **Do you think construction contracts differ in any way from general haulage contracts? How?**
- **Are there any [driver] safety elements to the contract?**

Prompts:

- Consider company type/size

Route planning and scheduling

- **How is it done/who does it?**

- **What about vulnerable road users like cyclists?**
- **What is effective and what is not effective?**
- **How would things be done in an ideal world?**

Prompts:

- Is the vehicle type and route type considered during planning?
- How do you check whether scheduled routes are followed?
- Is payment-per-load used and if so does this impact on scheduling?
- Is there pressure to meet agreed arrival times?
- Are periods of peak traffic flow avoided?

Risk assessment/safety management

- **How is it done/who does it?**
- **What about driving at work? (on and off site)**
- **To what extent is off-site safety included in safety management procedures?**
- **What about vulnerable road users like cyclists?**
- **Are there any other safety issues on site?**
- **What is effective and what is not effective?**
- **How would things be done in an ideal world?**

Prompts:

- What is your involvement in risk assessments?
- Is there a specific work-related driving road safety policy? If yes, does this relate to off-site as well as on-site driving? Who does the policy cover?
- To what extent do you feel drivers serving this construction site are pressured? In what way/examples?

Communication and reporting

- **How is it done/who does it?**
- **What about driving at work? (on and off site)**
- **What about vulnerable road users like cyclists?**
- **Are there any other safety issues on site?**
- **What is effective and what is not effective?**
- **How would things be done in an ideal world?**

Prompts:

- Is safety communication two-way?
- Are there any initiatives/incentives to report safety problems?
- How often are safety issues discussed?
- Are issues/incidents investigated?

Management and supervision

- **How do you manage subcontractors/how are you managed by your contractor?**
- **What commitment is there from senior management to safety?**
- **What about driving at work? (on and off site)**
- **What about vulnerable road users like cyclists?**
- **How would things be done in an ideal world?**

Prompts:

- What happens if legal health and safety requirements are not being met?
- How is commitment to safety demonstrated (or not demonstrated)?