

Traffic Modelling Guidelines

Version 4.0

Edited by

Lucy Beeston, Robert Blewitt, Sally Bulmer and James Wilson

© Transport for London, September 2021

All rights reserved. Reproduction permitted for research, private study and internal circulation within an organisation. Extracts may be reproduced provided the source is acknowledged.

Disclaimer

This publication is intended to provide accurate information. However, TfL and the authors accept no liability or responsibility for any errors or omissions or for any damage or loss arising from use of the information provided.

Foreword

London's roads have a vital role in realising the Mayor's vision for a fairer, greener, healthier and sustainable city. The road network is changing to enable our customers, goods and services to move about the Capital more efficiently and safely – especially for bus passengers, cyclists and pedestrians as part of the Mayor's vision.



A primary goal of Transport for London's Traffic Manager is to maintain network availability to ensure reliable operations on the Transport for London Road Network (TLRN) and Strategic Road Network (SRN). It is essential that all schemes proposing changes to the way our roads operate are developed to a high quality, that the impacts on the wider network are well understood and mitigated, and the contribution to achieving Mayoral policy is considered.

Operational modelling plays a central role in all scheme development and design, both through the high-quality technical assessments which are important for developing scheme designs and supporting business decisions, but also in the modelling information which stakeholders and customers have come to expect when they engage with scheme consultations.

These Guidelines provide valuable support to all transport professionals; they draw upon expertise from across the industry and form a comprehensive source of good practice.

I hope you find them useful in your daily work and I welcome any feedback or ideas you have. This will ensure that together we can continuously improve the Guidelines for the benefit of everyone.

A handwritten signature in black ink, appearing to read 'Glynn Barton'. The signature is fluid and cursive, with a long horizontal stroke at the end.

Glynn Barton

Director of Network Management

Traffic Manager for TfL

Acknowledgements

The editors would like to thank the following individuals for their significant contributions during the creation of this document:

Helen Cansick	Claire Kennedy
Alexander Clewes	Andrew Lovell
Tony Dichev	Abigail Moughal
Vytas Dumbliauskas	Paul Powell
Mark Eady	Birendra Shrestha
John Green	Pete Sykes
Dan Hornshaw	

The editors would also like to thank:

Gareth Bek	David Korzeniowski
Ollie Benford	Paul Moore
Jim Binning	Jonathan Morrow
Mark Brackstone	Carmen Muriana Cobo
Claire Cheriyan	John Nightingale
Chris Davis	Michael Oliver
Andy Emmonds	Georgia Perraki
Alastair Evanson	Charles Richardson
Robin Forrest	Simon Swanston
Paul Harwood	James Tate
Tessa Hayman	Sandra Weddell
Lukas Kautzsch	Domas Zemaitis
Susanna Kerry	

Additionally, the editors acknowledge and appreciate all contributions from those not named who have participated in this and previous versions of the document.

Contents

Foreword	3
Acknowledgements	4
Contents	5
Introduction	26
Part A	27
Part B	27
Part C	27
About the Authors	27
PART A – MODELLING CONSIDERATIONS	28
1 Introduction to Part A	29
2 Background to Highway Scheme Modelling in London	31
2.1 Legislative Responsibilities	31
2.1.1 Scheme Definition	33
2.1.2 Applying the Network Management Duty in TfL	33
2.2 Traffic Signals	35
3 Modelling Overview	36
3.1 What is a Model?	36
3.2 Why Do Modelling?	37
3.3 Basic Modelling Process	39
3.3.1 Replicating the Current Situation	39
3.3.2 Assessing Future Scenarios	39
3.3.3 Interpretation and Presentation of Modelling Results	40
3.4 Transport Modelling Hierarchy	41
3.4.1 Deterministic Modelling	41
3.4.2 Microsimulation Modelling	41
3.4.3 Tactical Modelling	43
3.4.4 Strategic Travel Demand Modelling	44
3.4.5 Model Integration	45
3.5 Three Stage Modelling	47
3.6 Modelling Standards	49
3.6.1 TfL Standards and Guidance	50
3.6.2 External Standards and Guidance	53
4 Stakeholder Engagement	54
4.1 Model Purpose	54
4.2 Key Stakeholders	55
4.3 Early Design Stages	55
4.4 Base Scoping Meeting	56
4.4.1 Modelling Scope	57
4.4.2 Site Visit and Data Collection	57
4.4.3 Modelling Expectations Document	58
4.5 Proposal Scoping Meeting	59
4.5.1 Strategy Considerations for Highway Scheme Development	59
4.5.2 Scheme Design	59

4.5.2.1	Scheme Safety	60
4.5.2.2	Junction Layout	61
4.5.2.3	Network Operation	61
4.5.2.4	Design Refinement	62
4.5.3	Public Transport Considerations	62
4.5.4	Pedestrian Considerations	63
4.5.5	Cyclist Considerations	63
4.5.6	Emissions Considerations	65
4.6	Final Design Stages	68
4.6.1	Scheme Impact Report	68
4.6.2	Public Consultation	69
5	Which Traffic Modelling Software? Why?	70
5.1	Deterministic Models	74
5.1.1	Signalised Networks	75
5.1.1.1	LinSig	75
5.1.1.2	TRANSYT	77
5.1.2	Priority Junctions	78
5.1.3	Pedestrian Modelling	78
5.2	Microsimulation Models	80
5.2.1	Traffic	81
5.2.1.1	Aimsun Next	82
5.2.1.2	Vissim	82
5.2.2	Pedestrians	83
5.2.2.1	LEGION	84
5.2.2.2	Viswalk	84
5.2.3	Emissions	84
5.2.3.1	EnViVer	85
5.2.3.2	PHEM	85
5.3	Tactical Models	86
5.3.1	Aimsun Next	87
5.3.2	SATURN	87
5.3.3	Visum	87
6	Summary	89
PART B – MODELLING GUIDANCE		90
1	Introduction to Part B	91
2	Modelling Principles	93
2.1	Modelling Overview	94
2.1.1	Levels of Modelling	94
2.1.1.1	Deterministic Modelling	94
2.1.1.2	Microsimulation Modelling	95
2.1.1.3	Tactical Modelling	96
2.1.1.4	Pedestrian Modelling	96
2.1.1.5	Emissions Modelling	97
2.1.2	Common Model Simplifications	97
2.1.3	Early Design Stages	99
2.1.4	Three Stage Modelling Process	100
2.1.4.1	Stage I: Base Model	101

2.1.4.2	Stage 2: Future Base Model	101
2.1.4.3	Stage 3: Do Something	101
2.1.4.4	When to use the Three Stage Modelling Process	102
2.1.4.5	Scheme Assessments	102
2.1.5	Model Auditing Process	103
2.1.5.1	Scoping Meetings	105
2.1.5.2	Modelling Expectations Document	105
2.2	Planning a Modelling Project	107
2.2.1	Network Familiarisation	107
2.2.2	Modelling Purpose	107
2.2.3	Spatial Scope	108
2.2.4	Required Outputs	109
2.2.5	Modelling Software	109
2.2.5.1	Versions of Modelling Software	110
2.2.6	Planning Traffic Surveys and Data Collection	110
2.3	Data Collection	111
2.3.1	Existing Data Sources	111
2.3.2	Site Visits	113
2.3.2.1	Sample Size	115
2.3.3	Typical Traffic Conditions	116
2.3.4	Private Transport	116
2.3.4.1	Traffic Count Surveys	117
2.3.4.1.1	Passenger Car Unit	118
2.3.4.2	Cruise Times / Speeds	119
2.3.4.3	Journey Times	120
2.3.4.4	Queue Lengths	121
2.3.5	Public Transport	122
2.3.5.1	Bus Journey Times	122
2.3.5.2	Bus Stop Usage and Dwell Times	123
2.3.5.3	Bus Lane Usage	123
2.3.6	Cyclists	124
2.3.6.1	Cyclist Counts	124
2.3.6.2	Cyclist Journey Times	124
2.3.7	Pedestrians	124
2.3.8	Signal Timings	125
2.3.8.1	Basic Principles	125
2.3.8.2	Types of Signal Control	128
2.3.8.3	UTC Junctions	129
2.3.8.3.1	Average SCOOT Timings	130
2.3.8.4	Non-UTC Junctions	131
2.3.8.5	Demand-Dependent Stages	132
2.3.8.6	Flared Approaches	133
2.3.8.7	Non-Green and Flashing Amber	133
2.3.9	Saturation Flow	134
2.3.9.1	Use of Calculation Formula RR67	136
2.3.10	Degree of Saturation	138
2.3.10.1	Underutilised Green Time	139
2.3.10.2	Measuring DoS	141
2.4	Base Model Development	145

2.4.1	Base Model Calibration	146
2.4.2	Base Model Validation	147
2.5	Proposed Model Development	148
2.5.1	Future Base	151
2.5.2	The Scheme Proposal	151
2.5.2.1	Changes to Junction Design	152
2.5.2.2	Changes to Traffic Flow	153
2.5.2.3	Demand Dependency Adjustments	154
2.5.2.4	Public Transport Adjustments	155
2.5.3	Sensitivity Testing	155
2.5.4	Construction Phases	156
2.5.5	Interaction Between Modelling Levels	157
2.5.6	Model Optimisation	158
2.5.6.1	Initial Optimisation	160
2.5.6.1.1	Underutilised Green Time	162
2.5.6.1.2	Junction Storage Effects	162
2.5.6.1.3	Cycle Time Optimisation	163
2.5.6.1.4	Junction Performance	164
2.5.6.1.5	Iteration with Tactical Models	165
2.5.6.2	Optimisation Fine Tuning and Impact Assessment	165
2.5.6.2.1	Balancing the Network	165
2.5.6.2.2	Utilisation of Network Capacity	167
2.5.6.2.3	Protecting the Network	167
2.5.6.2.4	Interaction with Microsimulation Modelling	168
2.5.6.2.5	Improving the Design	168
2.5.6.3	On-Street Implementation	168
2.5.7	Model Assessment	170
2.6	Model Reporting	171
2.6.1	Calibration Report	171
2.6.2	Validation Report	172
2.6.3	Future Base Report	173
2.6.4	Proposed Model Report	174
2.6.5	Scheme Impact Report	175
2.6.6	Public Consultation	176
2.6.7	Presentation of Modelling Outputs	176
2.6.8	3D Modelling	177
3	Aimsun Next Modelling	180
3.1	Introduction	180
3.1.1	Introduction to Aimsun Next	180
3.1.2	Software Versions	181
3.1.3	Appropriate Use of Aimsun Next	181
3.2	Preparation	183
3.2.1	Model Boundary	183
3.2.2	Data Collection	184
3.2.2.1	Site Observation	184
3.2.2.2	Signal Timings	185
3.2.2.3	Saturation Flows	186
3.2.2.4	Journey Times	186
3.2.2.5	Public Transport	187

3.2.3	Model Time Periods	187
3.2.4	Network Layout	188
3.2.4.1	Network Import	188
3.2.4.2	Transport Model Import	189
3.2.4.3	Background Import	190
3.3	Graphical User Interface	191
3.4	Base Model Calibration	193
3.4.1	Model Parameters	193
3.4.1.1	Simulation Step	193
3.4.1.2	Units	193
3.4.1.3	Rule of the Road	194
3.4.2	Network	194
3.4.2.1	Sections	194
3.4.2.2	Nodes and Turns	196
3.4.2.3	Junction Geometry	199
3.4.2.4	Side Lanes	200
3.4.2.5	Roundabout Geometry	202
3.4.2.6	Driving Behaviour	203
3.4.3	Traffic Data	205
3.4.3.1	Vehicle Types and Classes	205
3.4.3.2	Vehicle Network Entry	206
3.4.3.3	Warm-Up Demand	207
3.4.3.4	Public Transport	207
3.4.3.5	Pedal Cycles and Motorcycles	208
3.4.3.6	Pedestrians	209
3.4.4	Routing	209
3.4.4.1	OD Matrices	209
3.4.4.2	Traffic States	210
3.4.4.3	Route Choice Method	210
3.4.5	Signal Control	214
3.4.5.1	Controller Logic	214
3.4.5.2	Demand-Dependent Stages	215
3.4.5.3	Pedestrian Phases	216
3.4.5.4	Give-Ways and Stoplines	217
3.5	Base Model Validation	218
3.5.1	Randomness	218
3.5.2	Validated Model Requirements	218
3.5.2.1	Traffic Flows	219
3.5.2.2	Saturation Flows	219
3.5.2.3	Demand Dependency	220
3.5.2.4	Journey Times	220
3.5.2.5	Queue Data	221
3.5.2.6	Public Transport	221
3.5.3	Check and Fix	221
3.6	Proposed Model Development	223
3.6.1	Future Base	223
3.6.2	Scenario-Based Workflow	223
3.7	Model Outputs	226
3.7.1	Methods	226

3.7.1.1	Table View	227
3.7.1.2	Time Series	227
3.7.1.3	Validation	228
3.7.1.4	Database	229
3.7.1.5	Scripting	229
3.7.2	Data	229
3.7.2.1	Traffic Flows	230
3.7.2.2	Saturation Flows	231
3.7.2.3	Journey Times	231
3.7.2.4	Queue Data	232
3.7.2.5	Signal Timings	232
3.7.2.6	Vehicle Trajectory Files	232
4	LinSig Modelling	234
4.1	Introduction	234
4.1.1	Introduction to LinSig	234
4.1.2	Software Versions	235
4.1.3	Appropriate Use of LinSig	235
4.1.3.1	Junctions and Networks	235
4.1.3.2	Skeleton Models	236
4.1.3.3	Pedestrians	237
4.1.3.4	Proposed Design Changes	237
4.2	Preparation	238
4.2.1	Model Boundary	238
4.2.2	Data Collection	239
4.2.3	Model Time Periods	239
4.3	Graphical User Interface	240
4.3.1	Network Layout View	240
4.3.2	Error View	241
4.3.3	Scenarios	242
4.3.4	Controller Selection	242
4.4	Base Model Calibration	244
4.4.1	Calibrated Model	244
4.4.2	Network Settings	244
4.4.3	Network Structure	245
4.4.3.1	Junctions	245
4.4.3.2	Arms and Lanes	246
4.4.3.3	Connectors	246
4.4.3.4	Zones	246
4.4.3.5	Flared Approaches	247
4.4.3.6	Classification of Lanes	248
4.4.3.7	Saturation Flows	249
4.4.4	Signal Control	250
4.4.4.1	Controller Sets	250
4.4.4.2	Controller Input Data	251
4.4.4.3	Stage Sequences and Network Control Plan	252
4.4.4.4	Signal Timings View	252
4.4.5	Priority Control	253
4.4.5.1	Give-Way Parameters	253
4.4.5.2	Opposed Right-Turn Parameters	254

4.4.6	Traffic Flows and Flow Allocation	255
4.4.6.1	Lane-Based Flows	256
4.4.6.2	Matrix-Based Flows	258
4.4.6.3	Matrix Estimation	261
4.4.7	Public Transport	262
4.4.8	Pedestrians	264
4.4.9	Cyclists	265
4.5	Base Model Validation	266
4.5.1	Demand Dependency	266
4.5.2	Exit-blocking / Underutilised Green Time	267
4.5.3	Sliver Queues	267
4.5.4	Random Delay	268
4.5.5	Validated Model Requirements	269
4.6	Proposed Model Development	270
4.6.1	Future Base	270
4.6.2	Proposed Layout	270
4.6.3	Proposed Flows	271
4.6.3.1	Manual Editing	271
4.6.3.2	Tactical Modelling	271
4.6.3.3	Public Transport	272
4.6.4	Proposed Signal Timings	272
4.6.4.1	Optimisation	272
4.6.4.1.1	Cycle Time Optimisation	273
4.6.4.1.2	Signal Timing Optimisation	274
4.6.4.1.3	Optimisation Settings	275
4.6.4.2	Demand Dependency	276
4.6.4.3	Underutilised Green Time	276
4.6.4.4	Saturation Flows	276
4.7	LinSig Output	278
4.7.1	Network Results	278
4.7.2	Cyclic Flow Profile, Uniform Queue and Storage Graphs	279
4.7.3	Travel Time / Delay Matrix View	281
4.7.4	Report Builder	282
4.7.5	Model Audit View	282
5	Highway Traffic Assignment	283
5.1	Introduction	283
5.2	Use of HTA Models in TfL	285
5.2.1	Strategic HTA Models	285
5.2.2	Tactical HTA Models	285
5.3	Traffic Assignment Requirements	287
5.3.1	Mesoscopic Models	287
5.4	Preparation	289
5.4.1	Model Boundaries	289
5.4.2	Data Collection	290
5.4.3	Model Time Periods	290
5.5	Base Model Calibration	291
5.5.1	Travel Demand	291
5.5.1.1	Travel Demand Data	291
5.5.1.2	Zones	291

5.5.1.3	Connectors	292
5.5.2	Network	292
5.5.2.1	Buffer Network	292
5.5.2.2	Links	293
5.5.2.3	Nodes	294
5.5.2.3.1	Signal Controlled Junctions	294
5.5.2.3.2	Priority Junctions	295
5.5.2.3.3	Roundabouts	295
5.5.2.3.4	Unspecified Nodes	296
5.5.2.3.5	Main Nodes / Junctions	296
5.5.3	Public Transport	297
5.5.4	Cyclists	297
5.5.5	Calibration Tools	297
5.5.6	Matrix Estimation	298
5.6	Convergence Criteria	299
5.7	Base Model Validation	301
5.7.1	Matrix Validation	301
5.7.2	Assignment Validation	301
5.7.2.1	Traffic Flow Criteria	301
5.7.2.2	Journey Time Validation	302
5.8	Proposed Model Development	304
5.8.1	Future Base	304
5.8.2	Traffic Demand	304
5.8.3	Signal Timings	305
5.8.4	Saturation Flows	305
5.8.5	Public Transport	305
5.9	Model Outputs	306
5.9.1	Model Noise	306
6	TRANSYT Modelling	308
6.1	Introduction	308
6.1.1	Introduction to TRANSYT	308
6.1.2	Software Versions	309
6.1.3	Principles of TRANSYT	309
6.1.4	Appropriate Use of TRANSYT	310
6.2	Preparing to build a TRANSYT Model	312
6.3	Graphical User Interface	313
6.3.1	Network Visualisation	313
6.3.2	TranEd interface to TRANSYT 12 ^[T12]	313
6.3.3	Data Input and Output Files	314
6.3.4	Data Outline, Data Editor, Data Grids and Data Finder ^[T16]	314
6.3.5	Analysis Sets and Demand Sets ^[T16]	316
6.4	Base Model Calibration	317
6.4.1	Calibrated Model	317
6.4.2	Network Options	317
6.4.3	Traffic Behaviour Models	320
6.4.3.1	Platoon Dispersion Model	320
6.4.3.2	Link-by-Link Platoon Dispersion Model ^[T16]	321
6.4.3.3	Congested Platoon Dispersion Model (CPDM) ^[T16]	322
6.4.3.4	Cell Transmission Model ^[T16]	322

6.4.3.5	Simulation Model ^[T16]	325
6.4.3.6	Guidance on Traffic Model Choice	326
6.4.4	Network Structure	328
6.4.4.1	Nodes	328
6.4.4.2	Links and Traffic Streams	329
6.4.4.3	Major and Minor Links (Link Shares)	331
6.4.4.4	Flared Approaches	331
6.4.4.5	Classification of Links and Traffic Streams	333
6.4.4.6	Properties of Links and Traffic Streams	334
6.4.4.6.1	Minor Links	335
6.4.4.6.2	Bottleneck Links / Traffic Streams	335
6.4.4.6.3	Entry and Exit Links / Traffic Streams	336
6.4.5	Signal Control	336
6.4.5.1	Network Cycle Time	337
6.4.5.2	Phase-Based Controller Behaviour	337
6.4.5.3	Node-Based Signal Timings ^[T12]	339
6.4.5.3.1	Adjustment of Start and End Lags	339
6.4.5.4	Controller-Based Signal Timings ^[T16]	340
6.4.5.5	Demand-Dependent Stages	341
6.4.5.6	Underutilised Green Time (UGT)	343
6.4.6	Priority Control	344
6.4.6.1	Opposed Movements at Signals	344
6.4.6.1.1	Traditional Give-Way Model	345
6.4.6.1.2	Step-wise Opposed Turn Give-Way Model	347
6.4.6.2	Mutually Opposed Traffic Movements	348
6.4.6.3	Opposed Movements near Signals – Indirect Traffic Control ^[T16]	348
6.4.6.4	Priority Junctions and Roundabouts	348
6.4.6.5	Priority Objects ^[T16]	351
6.4.6.6	Congested Priority Behaviour in the Cell Transmission Model ^[T16]	352
6.4.7	Traffic Flows and Flow Allocation	353
6.4.7.1	Direct Flow Entry (Link-Based Networks)	353
6.4.7.2	Local OD Matrix Flow Entry ^[T16]	354
6.4.7.3	Wide Area Flow Matrices ^[T16]	357
6.4.7.4	Time-Varying Flow Profiles ^[T16]	358
6.4.8	Public Transport	360
6.4.9	Pedestrians	362
6.4.10	Cyclists	363
6.5	Base Model Validation	364
6.5.1	Flow Inconsistencies	364
6.5.2	Oversaturation	364
6.5.3	Excess Queues	365
6.6	Proposed Model Development	366
6.6.1	Future Base	366
6.6.2	Proposed Layout	366
6.6.3	Proposed Flows	367
6.6.3.1	Tactical Modelling	367
6.6.3.2	Public Transport	368
6.6.4	Proposed Signal Timings	368

6.6.4.1	Optimisation	369
6.6.4.1.1	Initial Signal Timings	369
6.6.4.1.2	Existing Network Performance	370
6.6.4.1.3	Optimisation Algorithms	370
6.6.4.1.4	Cycle Time Optimisation	371
6.6.4.1.5	Optimising Green Splits and Offsets	372
6.6.4.1.6	Stop and Delay Weightings	373
6.6.4.1.7	Queue Limits	373
6.6.4.1.8	Degree of Saturation Limits ^[T16]	374
6.6.4.2	Demand Dependency	375
6.6.4.3	Underutilised Green Time	375
6.6.4.4	Saturation Flows	375
6.7	Model Outputs	376
6.7.1	Numerical / Table-based Outputs	376
6.7.1.1	Model Data Comparison Tool ^[T16]	378
6.7.2	Graphical Outputs	379
6.7.2.1	Network Diagram Overlays	379
6.7.2.2	Queue and Flow Graphs	380
6.7.2.3	Performance Index Graphs	381
6.7.2.4	Cycle Time Optimisation Graphs	382
6.7.2.5	Time-distance Graphs	383
6.7.2.6	Analysers – X-Y and Time Graphs ^[T16]	384
6.7.2.7	Traffic Simulation ^[T16]	385
7	Vissim Modelling	387
7.1	Introduction	387
7.1.1	Introduction to Vissim	387
7.1.2	Software Versions	388
7.1.3	Appropriate Use of Vissim	388
7.2	Preparation	390
7.2.1	Model Boundary	390
7.2.2	Data Collection	391
7.2.2.1	Site Observation	392
7.2.2.2	Signal Timings	393
7.2.2.3	Saturation Flows	393
7.2.2.4	Journey Times	394
7.2.2.5	Public Transport	394
7.2.3	Model Time Periods	395
7.2.4	Background Images	395
7.3	Graphical User Interface	397
7.3.1	Network Objects	397
7.3.2	Lists	398
7.3.3	Quick View	400
7.3.4	Scenario Management	401
7.4	Base Model Calibration	402
7.4.1	Model Parameters	403
7.4.1.1	Start Time and Date	404
7.4.1.2	Simulation Resolution	404
7.4.1.3	Random Seed	404
7.4.1.4	Units	404

7.4.1.5	Traffic Regulations	405
7.4.2	Network	406
7.4.2.1	Links and Connectors	406
7.4.2.2	Link Driving Behaviour	407
7.4.2.3	Reduced Speed Areas and Desired Speed Decisions	409
7.4.2.4	Saturation Flows	410
7.4.2.5	Priority Rules and Conflict Areas	411
7.4.2.5.1	Priority Rules	412
7.4.2.5.2	Conflict Areas	415
7.4.2.6	Externally Generated Congestion	415
7.4.3	Traffic Data	416
7.4.3.1	Vehicle Models, Types, Categories and Classes	416
7.4.3.2	Functions and Distributions	418
7.4.3.3	Compositions and Demand	418
7.4.3.4	Public Transport	419
7.4.3.5	Cyclists and Motorcycles	420
7.4.3.6	Pedestrians	420
7.4.4	Routing	421
7.4.4.1	Static Routing	421
7.4.4.2	Dynamic Assignment	423
7.4.4.2.1	Convergence	424
7.4.5	Signal Control	425
7.4.5.1	VAP Controller Logic	425
7.4.5.2	Demand-Dependent Stages in VAP	425
7.4.5.3	UTC-Vissim	426
7.5	Base Model Validation	427
7.5.1	Randomness	427
7.5.2	Validated Model Requirements	428
7.5.2.1	Traffic Flows	428
7.5.2.2	Saturation Flows	429
7.5.2.3	Demand Dependency	430
7.5.2.4	Journey Times	430
7.5.2.5	Queue Data	431
7.5.2.6	Public Transport	432
7.5.2.7	Error Files	432
7.5.3	Use of Multithreading	432
7.6	Proposed Model Development	433
7.6.1	Future Base	433
7.6.2	Scenario Management	433
7.6.3	Proposed Flows and Routing	434
7.6.3.1	Input Adjustments	435
7.6.3.2	Tactical Modelling	435
7.6.4	Proposed Signal Timings	435
7.6.5	Proposed Saturation Flows	436
7.6.6	Proposed Public Transport	436
7.7	Model Outputs	437
7.7.1	Methods	437
7.7.1.1	Numerical Outputs	437
7.7.1.2	Network Object Display	441

7.7.1.3	Charts	441
7.7.1.4	Scripting	442
7.7.2	Data	442
7.7.2.1	Traffic Flows	442
7.7.2.2	Saturation Flows	444
7.7.2.3	Journey Times	444
7.7.2.4	Queue Data	445
7.7.2.5	Signal Timings	446
7.7.2.6	Network Performance	447
7.7.2.7	Vehicle Trajectory Files	447
PART C – THE HEALTHY STREETS APPROACH		449
1	Introduction to Part C	450
2	Cyclist Modelling	452
2.1	Introduction	452
2.1.1	Case Study	453
2.2	Research	457
2.2.1	TfL Research	457
2.2.1.1	Cyclist-Vehicle Interaction at ASLs	457
2.2.1.2	Cyclist Saturation Flows at Segregated Stoplines	457
2.2.2	TRL Research	458
2.2.2.1	Cycle Behaviour and Dispersion Research	458
2.2.2.2	Impact of Cyclists on Saturation Flows	459
2.2.3	Cynemon	460
2.3	Data Collection	461
2.3.1	Flows and Routing	463
2.3.2	Journey Times	464
2.4	Cyclist Modelling	465
2.4.1	Deterministic or Microsimulation?	466
2.5	Deterministic Modelling	467
2.5.1	Segregated Cyclists	467
2.5.2	Non-Segregated Cyclists	468
2.6	Microsimulation Modelling	470
2.6.1	Links and Behaviour Parameters	470
2.6.1.1	Segregated Links	471
2.6.1.2	Non-Segregated Links	472
2.6.1.3	General	474
2.6.2	Composition	474
2.6.3	Speed and Acceleration	474
2.6.4	Routes	475
2.6.5	Stopline Capacity for Segregated Cyclists	475
2.6.6	Stopline Capacity for Non-Segregated Cyclists	476
2.6.7	Validation	478
3	Pedestrian Modelling	479
3.1	Introduction	479
3.1.1	Case Study	480
3.2	Relevant Guidance Documents	485
3.2.1	Pedestrian Comfort Guidance for London	485
3.2.2	LEGION Best Practice Guide	486

3.2.3	Station Planning Standards and Guidelines	486
3.2.4	Planning for Walking Toolkit	486
3.3	Modelling Approach	487
3.3.1	Static Modelling	487
3.3.1.1	Pedestrian Comfort Levels	488
3.3.1.2	PCLs and Signal Timings at Crossings	490
3.3.1.3	Wait Times at Signalised Crossings	491
3.3.1.4	Station Planning Standards and Guidelines	492
3.3.2	Dynamic Modelling	493
3.3.2.1	LEGION	494
3.3.2.2	Viswalk	495
3.4	Preparation	496
3.4.1	Modelling Expectations Document	496
3.4.2	Time Periods	497
3.4.3	CAD Preparation	497
3.4.4	Public Transport Hubs	499
3.4.5	Data Collection	499
3.4.5.1	Site Observation	499
3.4.5.2	Dates and Times	500
3.4.5.3	Flows and Journey Times	501
3.4.5.4	Public Transport Data	502
3.4.5.5	Signal Timing Data	503
3.4.6	Demand	504
3.4.7	Pedestrian Types	506
3.4.7.1	PRM Types	506
3.4.7.2	Default PRM Proportions	508
3.4.7.3	Default PRM Speed Distributions	508
3.5	Model Building and Development	510
3.5.1	Entity Routing	510
3.5.2	Street Level Footways	511
3.5.3	Bus Service Intervals and Dwell Times	513
3.5.4	Bus Stops	513
3.5.5	Pedestrian Crossings	514
3.5.5.1	Signalised Junctions	515
3.5.5.2	On-demand Crossings	517
3.5.5.3	Zebra Crossings	517
3.5.5.4	Informal Crossing	518
3.5.6	Validation	518
3.5.6.1	Randomness	518
3.5.6.2	Requirements	520
3.5.7	Proposed Models	520
3.5.7.1	Future Base	520
3.5.7.2	Proposals	521
3.6	Model Outputs and Analysis	522
3.6.1	Crowding Levels	523
3.6.1.1	Fruin's Levels of Service	523
3.6.1.2	Pedestrian Comfort Levels	525
3.6.2	Plots	527
3.6.2.1	Cumulative Mean Density	528

3.6.2.2	Cumulative High Density	529
3.6.2.3	Space Utilisation	530
3.6.3	Journey Times	530
3.6.4	Social Costs	531
3.6.5	Screenshots and Videos	531
4	Emissions Modelling	533
4.1	Introduction	533
4.1.1	Scope	535
4.1.2	Case Study	535
4.2	Methodology	537
4.2.1	Microsimulation Modelling	538
4.2.1.1	Model Boundaries	539
4.2.1.2	Vehicle Types	539
4.2.1.3	Vehicle Dynamics	539
4.2.1.4	Road Gradient	539
4.2.1.5	Model Calibration and Validation	540
4.2.1.6	Model Output Configuration	541
4.2.1.7	Running the Model	542
4.2.2	Emissions Modelling	542
4.2.2.1	Fuel Types	542
4.2.2.2	Euro Engine Standards	543
4.2.2.3	Running the Model	543
4.2.3	Output Reporting	544
4.3	EnViVer	546
4.3.1	Inputs	547
4.3.1.1	Vehicle Record Data	547
4.3.1.2	Vehicle Fleet Definition File	548
4.3.1.3	Assigning EnViVer Emissions Classes	550
4.3.1.4	Data Verification	551
4.3.2	Outputs	552
4.3.2.1	Report	552
4.3.2.2	Plots	552
4.3.2.3	Post Processing	553
4.4	PHEM	555
4.4.1	Inputs	556
4.4.1.1	Job File	556
4.4.1.2	Vehicle Record Data	559
4.4.1.3	Vehicle Fleet Composition File	561
4.4.1.4	Segment Data File	561
4.4.2	Outputs	562
4.4.2.1	Mod File	562
4.4.2.2	Vehicle Sum File	563
4.4.2.3	Segment Sum File	563
	CLOSING SUMMARY	565
	CONTACTS	566
	GLOSSARY	567
	APPENDICES	575

Appendix I: Underutilised Green Time Calculation	576
Appendix II: Flow Comparison (The GEH Statistic)	578
Appendix III: TRANSYT 12 Node / Link Labelling Convention	580
Appendix IV: Vissim Dynamic Assignment Convergence Methods	583

LIST OF FIGURES

Figure 1: The TLRN (shown in blue) and the SRN in (shown in pink)	32
Figure 2: DfT's hierarchy of user provision	34
Figure 3: Transport modelling hierarchy	42
Figure 5: The TfL Three Stage Modelling Process	47
Figure 6: The relationship between the Traffic Modelling Guidelines and MAP	50
Figure 7: Cyclic Flow Profile graph, showing previously delayed vehicles (dark green), vehicles arriving on green (light green) and vehicles arriving on a red signal (red)	76
Figure 8: Cyclic Flow Profile graph, showing previously delayed vehicles (blue), vehicles arriving on green (green) and vehicles arriving on a red signal (red)	77
Figure 9: The TfL Three Stage Modelling Process	100
Figure 10: Interactions between different levels of modelling within the Three Stage Modelling Process	103
Figure 11: Flow profiles showing 'normal' (blue) and 'congested' (orange) conditions	140
Figure 12: Congested conditions as modelled in LinSig or TRANSYT with UGT	140
Figure 13: Incorrectly reduced saturation flow analogous to UGT applied in Figure 12	141
Figure 14: Diagram indicating periods of high and low demand	142
Figure 15: Schematic diagram outlining a generalised approach to Base model development for TfL	146
Figure 16: Schematic diagram outlining a generalised approach to Proposed model development for TfL	150
Figure 17: Overview of a proposed approach to traffic model optimisation	159
Figure 18: Initial optimisation approach	161
Figure 19: Relationship between junction delay and degree of saturation	164
Figure 20: Optimisation fine tuning and impact assessment approach	166
Figure 21: Derivation of on-street controller timings	169
Figure 22: An example of a static computer-generated image produced for a public consultation	178
Figure 23: An example of an animation video produced using outputs from a Vissim model, with the existing image shown above and the scheme image shown below	179
Figure 24: Analysing when the model becomes stable	188
Figure 25: Illustration of network geometry adjustments	189
Figure 26: New Project window	191
Figure 27: Aimsun Next 20 GUI	192
Figure 28: Bus bay length	195
Figure 29: Extract from Node window showing Dynamic Models options	197
Figure 30: Advanced stop lines (dark grey boxes) at a traffic signal	198
Figure 31: A junction with filters and a central reserve with the recommended construction method on the right	199
Figure 32: Angled Section entrances and exits. The top row would be considered too sharply angled.	199
Figure 33: Use of a Side Lane to model a merge	200
Figure 34: Side lane lengths. The Section on the left is too short.	200
Figure 35: Section On-Ramps with correct Side Lane usage below	201

Figure 36: Complex merges	201
Figure 37: Mini roundabout coded as a Node	202
Figure 38: A single lane roundabout generated using the roundabout tool	202
Figure 39: A multi-lane roundabout with the recommended construction method on the right	203
Figure 40: Road Type parameters	204
Figure 41: Vehicle Type parameters	205
Figure 42: Arrival profile options	206
Figure 43: Public Transport Line timetable window	208
Figure 44: Vehicle actuated (VA) signal control	216
Figure 45: Assigning turn parameters	217
Figure 46: Microsimulator Network Checker window	222
Figure 47: Dynamic Scenario Outputs to Generate tab	226
Figure 48: Time Series windows	227
Figure 49: Real Data Set windows	228
Figure 50: Validation tab of a Replication	229
Figure 51: Subpath definition	230
Figure 52: Dynamic Scenario Aimsun Next APIs tab	231
Figure 53: FZP Exporter activation and settings	233
Figure 54: Network Layout View	240
Figure 55: LinSig Error View	241
Figure 56: LinSig Scenarios View	242
Figure 57: Controller selection within LinSig Controller Data Windows	243
Figure 58: Example junction showing Arms, Lanes, Connectors and Zones in LinSig	245
Figure 59: Combined (left) and separate (right) capacity results for Short Lanes	247
Figure 60: Example of junction Exit Arms being used between two junctions in LinSig	249
Figure 61: Controller List View, showing Controller Sets and cycle times	250
Figure 62: LinSig Network Control Plans View window	252
Figure 63: LinSig Signal Timings View window	253
Figure 64: Flow Group definition in LinSig	255
Figure 65: Lane-Based Flow Layers dialog box	256
Figure 66: Lane-Based Flow Entry Mode, showing different Flow Layers in different colours	256
Figure 67: Lane-Based Flow Layer editing in the Edit Lane View	257
Figure 68: Flow Consistency Mode, with flow inconsistencies highlighted in blue	257
Figure 69: Traffic Flow OD Matrix shown in the Traffic Flows View	258
Figure 70: Route List View	259
Figure 71: Edit Permitted Routes View	259
Figure 72: Traffic OD Matrix Difference view, indicating where desired and actual flows are not matching in grey	260
Figure 73: Example junction showing a pedestrian network in LinSig	264
Figure 74: Lane Timings View, showing positive bonus green applied to Lanes 1/1, 1/2 and 1/3, and a negative bonus green applied to Lane 3/1	266
Figure 75: Formation of a sliver queue in a LinSig uniform queue graph (left) and removal using appropriate de-sliver threshold (right)	268
Figure 77: Network Results View	278

Figure 78: Cyclic Flow Profile graph, showing previously delayed vehicles (dark green), vehicles arriving on green (light green) and vehicles arriving on a red signal (red)	279
Figure 79: Uniform Queue graph in LinSig	280
Figure 80: Example of storage graphs in LinSig	281
Figure 81: LinSig Model Audit View, highlighting differences between two compared files	282
Figure 82: TfL's MoTiON Model	286
Figure 83: The TRANSYT optimisation process, adapted from the TRANSYT 12 user guide	310
Figure 84: T16 Network Diagram window	313
Figure 85: TRANSYT 16 – Data Outline and Data Editor windows	315
Figure 86: TRANSYT 16 – Data Grid window	316
Figure 87: TRANSYT 16 – Selected Analysis Set (A2) and Demand Set (D3)	316
Figure 88: Cyclic Flow Profiles for neighbouring stoplines (viewed in TranEd)	321
Figure 89: Cells within a CTM section, coloured by traffic occupancy	322
Figure 90: Traffic Model selection	326
Figure 91: Traffic Stream structure (left) and equivalent Link structure (right)	329
Figure 92: Alternative fare representations in T16 using a Quick Flare (above) and with the Flare traffic model (below)	332
Figure 94: Congested give-way behaviour in the Cell Transmission Model, adapted from the TRANSYT 16 user guide	352
Figure 97: User-specified flow Allocation Types for individual Paths	356
Figure 98: Maintaining lane-specific flows at Local Location boundaries	357
Figure 99: Use of Assignment Cost Weightings to influence assigned flows	358
Figure 100: Specifying multiple time segments within a T16 model	359
Figure 101: Time Segment drop-down selection menu	359
Figure 103: Example of model results shown in the T16 Report Viewer	377
Figure 106: T16 Network Diagram Overlay showing queue and flow data	379
Figure 107: Uniform queue graphs, viewed in TranEd and TRANSYT 16	380
Figure 108: Cyclic Flow Profile graphs, viewed in TranEd (left) and TRANSYT 16 (right)	381
Figure 109: Performance Index graphs, viewed in TranEd and TRANSYT 16	382
Figure 110: Cycle Time Optimisation graphs in TranEd and TRANSYT 16	382
Figure 111: Time-Distance graphs in TranEd and TRANSYT 16	383
Figure 112: T16 Analyser (X-Y) graph showing P.I. versus cycle time for two Collections	384
Figure 113: Animation of individual vehicles in a Traffic Simulation random seed trial	385
Figure 114: T16 simulation showing 90 th percentile queues	386
Figure 115: Signals Log in TRANSYT 16	386
Figure 116: Network Objects window and a typical right-click menu	397
Figure 117: Linked Lists with Links on the left and Static Vehicle Routes on the right	398
Figure 118: Linked Lists with Public Transport Lines on the left and Public Transport Line Stops on the right	398
Figure 119: Node Results List	399
Figure 120: Screenshot showing Link characteristics in different colours	399

Figure 121: Quick View (Vehicles In Network) window	400
Figure 122: Project Structure window	401
Figure 123: Simulation Parameters window	403
Figure 124: Network Settings window	405
Figure 125: Lane merge layout options with the recommended layout on the right	407
Figure 126: Driving Behaviour window	409
Figure 127: Placement of RSAs for saturation flow calibration	411
Figure 128: Priority Rule configurations showing the effect of different placements of the Conflict Marker	412
Figure 129: Configuration of Priority Rules to account for Headway and Gap Time separately	413
Figure 130: Example of a 'yellow box' Priority Rule setup	414
Figure 131: Example Vehicle Class	417
Figure 132: Public Transport Line departure times generator window	419
Figure 133: Example of cumulative observed vs. modelled journey times	431
Figure 134: Screenshot of Project Explorer window	434
Figure 135: Evaluation Configuration window, Result Management tab	438
Figure 136: Evaluation Configuration window, Result Attributes tab	439
Figure 137: Evaluation Configuration window, Direct Output tab	440
Figure 138: Results List window	440
Figure 139: Links with a colour scheme based on speed	441
Figure 140: Example of a Chart	442
Figure 141: Example Node layout	443
Figure 142: Setting to record saturation flows from Signal Heads	444
Figure 143: Vehicle travel times setting	445
Figure 144: Queue length bars	446
Figure 145: Signal Times Table	446
Figure 146: Vehicle Network Performance Evaluation Results	447
Figure 147: Animation file (*.ani.txt) example	447
Figure 148: Vehicle record file (*.fzp) data selection	448
Figure 149: East-West Cycle Superhighway proposed route alignment	453
Figure 150: Proposed changes at Parliament Square for EWCR	455
Figure 151: Cyclists on EWCR	456
Figure 152: Cyclist trips throughout 2019	461
Figure 153: Cyclist not impeding other traffic	462
Figure 154: Modelling of a segregated cycle lane in a deterministic model. with fixed green times based on cycle lane widths	468
Figure 155: Lane widths showing 0.5m clearance between opposite directions	471
Figure 156: Stoplevel location and decreasing link widths	472
Figure 157: Cyclist overtaking a bus at a bus stop	473
Figure 158: Vissim cyclists forming queues at various lane widths	476
Figure 159: Diagram showing Travel Time Section start and end locations	478
Figure 160: Layout of PSSP proposal	481
Figure 161: Heat map showing the Cumulative Mean Density for pedestrians across the peak 15 minutes, using Fruin's LoS for walkways	483
Figure 162: 3D visualisation of the PSSP modelling	484
Figure 163: Pedestrian Comfort Levels applied to sections of footway	489

Figure 164: LEGION Model Builder screenshot	494
Figure 165: Pedestrian part of the Network Objects window in Vissim	495
Figure 166: CAD showing an OS tile and topographical drawing	498
Figure 167: Example of the LDT with arrival profiles in 15-minute sections, noise between 0 and 2 and random arrival within that time period	505
Figure 168: Example LEGION arrival profile	505
Figure 169: Viswalk pedestrian OD matrix	506
Figure 170: A staircase linking levels in a LEGION model	512
Figure 171: Vissim screenshot showing different levels	512
Figure 172: Example Bus Stop with shelter in LEGION	514
Figure 173: Availability profile for a crossing in LEGION	515
Figure 174: Example of pedestrian crossings in LEGION	516
Figure 175: Signalised pedestrian crossing in Vissim	517
Figure 176: Fruin's Levels of Service for walkways, stairs and queues	524
Figure 177: Pedestrian Comfort Levels	526
Figure 178: Example heat map showing Cumulative Mean Density, with Fruin's LoS for walkways	529
Figure 179: Example heat map showing Cumulative High Density: Time spent above LoS D using Fruin's LoS for walkways	529
Figure 180: Space utilisation plot	530
Figure 181: Modelled pedestrians in a 3D scene	532
Figure 182: Speed profile of a vehicle	537
Figure 183: Emissions modelling process	538
Figure 184: EnViVer main page	546
Figure 185: Format of the vehicle record data file (*.fzp) needed for EnViVer import	548
Figure 186: EnViVer custom vehicle distribution configuration window	549
Figure 187: Vehicle-class assignments window screenshot	550
Figure 188: EnViVer Speed-Acceleration plot	551
Figure 189: EnViVer speed and acceleration plot for an individual vehicle	552
Figure 190: A screenshot showing EnViVer plot of PM ₁₀ emissions	553
Figure 191: Excerpt from an EnViVer output file (*.asc) file and Excel plot of the output file values	553
Figure 192: Options tab in the PHEM user interface	555
Figure 193: ADV editor which can be used to generate job files (*.adv)	557
Figure 194: Screenshot of the Job Files tab in the PHEM user interface	558
Figure 195: An example vehicle record data file (*.fzp) extract	560
Figure 196: An example fleet composition file (*.flt) extract	561
Figure 197: An example segment data file (*.str)	561
Figure 198: An example mod file (*.mod) extract	562
Figure 199: An example vehicle sum file (*.vehicle.sum) extract	563
Figure 200: An example segment sum file (*.sum) extract	563
Figure 201: Difference in NO _x levels between two scenarios	564
Figure 202: TRANSYT Node and Link labelling system (shown for J05/066)	580

LIST OF TABLES

Table 1: Task description for the different parties involved in MAP	52
Table 2: Key features of the different levels of modelling	72
Table 3: Passenger Car Unit (PCU) values for various vehicle types	119
Table 4: Junction performance classifications based on Webster & Cobbe ⁵⁴ and updated by TRL	137
Table 5: Classifications for high and low demand examples shown in Figure 14	143
Table 6: An example of reporting time ranges	177
Table 7: Decision table for determining route choice method in Aimsun Next	212
Table 8: Traffic signal terminology used in Aimsun Next	215
Table 9: Lane control types in LinSig	248
Table 10: Matrix estimation monitoring	299
Table 11: Convergence indicators from TAG ⁸⁰	300
Table 12: TAG traffic flow validation criteria	302
Table 13: TRANSYT Link and Traffic Stream comparisons	330
Table 14: Observed discharge rates of cyclists at segregated stoplines	458
Table 15: TRL-measured cycle speeds ¹¹³	459
Table 16: PRM type definitions	507
Table 17: PRM proportions	508
Table 18: PRM speed distributions	509
Table 19: Modelling methods required for different output types	522
Table 20: PCLs related to high street pedestrian experience and Fruin LoS for walkways	527
Table 21: Comparative analysis contrasting GEH and percentage values	578

Introduction

The Traffic Modelling Guidelines have been produced by Transport for London's (TfL) Network Management Directorate (NM) that sits within Surface Transport. The following document represents the views and needs of a broad spectrum of traffic modelling practitioners with contributions from departments across TfL and external industry experts

The Director of NM is the TfL Road Network Traffic Manager and therefore has a duty to secure the expeditious movement of people and goods (collectively termed 'Traffic' in this document) as detailed in the 2004 Traffic Management Act¹). NM is dependent on comprehensive modelling and supporting information from clients (including London boroughs and TfL departments) and consultants in order to design, assess, implement and operate traffic schemes effectively.

Appropriate, comprehensive and accurate modelling is necessary to ensure permanent traffic schemes can be:

- Fully assessed for impacts and benefits;
- Effectively designed to satisfy original objectives and mitigate any adverse impacts;
- Clarified to avoid confusion or misinterpretation of the design;
- Effectively and efficiently implemented and operated; and
- Implemented with an accurate prediction of operation within a high level of confidence.

NM has developed these Guidelines to help inform modellers, network operations practitioners and scheme Promoters. They encourage consistency, promote best practice and are intended to deliver improvements in modelling quality. The aim is that this will in turn promote high quality scheme design that delivers and maintains appropriate balanced network performance across all transport modes, in line with relevant policies in place at the time.

Since the previous version of the Traffic Modelling Guidelines² was published in September 2010, this new version has been produced to bring the document up to date and to ensure that guidance is compliant with current best practice.

¹ Great Britain, Traffic Management Act 2004: Elizabeth II, Chapter 18, The Stationery Office, London, 2004

² RSM Modelling Guidelines v3.0: Traffic Schemes in London Urban Networks, Directorate of Road Space Management, Transport for London, 2010

The Traffic Modelling Guidelines are now separated into three parts to simplify access and use:

Part A

Part A has been written to give a high-level understanding of traffic modelling as it applies in a TfL context. It is designed to be read by a wide audience, both internally and externally, including non-technical decision makers, project managers and scheme Promoters. It does not assume any prior knowledge of traffic modelling.

Part B

Part B contains technical guidance relating to the use of traditional traffic modelling software. The first chapter covers topics which are common to all types of traffic model, while subsequent sections provide more detailed guidance on modelling best practice for specific types of traffic model.

Part C

Part C contains evolving modelling guidance that continues to be developed to support active travel modes as advocated through the Mayor's Transport Policy, which focuses on promoting health and reducing reliance on private vehicle use.

About the Authors

These Guidelines have been compiled and edited by staff from TfL's Network Performance (NP) department, within NM. Staff within NP possess a high level of technical modelling expertise, which has been developed internally in TfL and under predecessor organisations such as the Traffic Control Systems Unit. Modelling specialists within NP are responsible for developing TfL's modelling assets and undertaking advanced model assessments to support highway development.

A wide range of TfL staff, many of whom are respected as subject matter experts in the traffic modelling field, have contributed significantly to the development and review of these Guidelines.

PART A – MODELLING CONSIDERATIONS



I Introduction to Part A



The Network Management Directorate (NM) within TfL Surface Transport is responsible for the management and operation of London's 6,000+ traffic signals and their accompanying systems, technologies and equipment.

NM is a centre of traffic engineering expertise and applies traffic modelling in two core areas:

- The Network Performance Delivery (NPD) section, where traffic models are used for signal design optimisation, operational timing reviews and traffic scheme impact assessments; and
- The Network Performance Modelling & Visualisation team (M&V), which provides modelling assurance through expert modelling support of traffic scheme impact assessments and is responsible for development of the Model Auditing Process (MAP), Traffic Modelling Guidelines and the Operational Network Evaluator (ONE) assignment model.

Part A of these Traffic Modelling Guidelines has been written to give a high-level understanding of traffic modelling as it applies within a TfL context. It is designed to be read by a wide internal and external audience, including non-technical project managers and scheme Promoters. It does not assume any prior knowledge of traffic modelling.

Part A introduces the background to traffic modelling in London with an outline of TfL's legislative responsibilities, including its Traffic Manager

duties, policy considerations and requirements to deliver against relevant road network performance metrics. It covers the reasons why modelling is appropriate, how it should be carried out and who is involved.

At the core of **Part A** is the modelling hierarchy, which shows how different levels of modelling interact and relate both to each other and the process of modelling as a whole.

The key requirements to produce traffic modelling to a suitable standard are outlined along with a brief description of the model submission process and the presentation of modelling results.

Developing models to a correct standard, and using these models to inform the design process, requires expertise and experience on behalf of the model developer and the design team. A scheme Promoter (section **A3.6.1**) should ensure that any consultant they appoint possesses the requisite experience and expertise. This chapter provides guidance to the scheme Promoter on necessary expertise and outlines some of the basic fundamentals which must be met by the model developer and the design team using the model.

The final chapter introduces a range of traffic modelling software and describes the applications and outputs of each. It provides a context for the remainder of the Guidelines.

2 Background to Highway Scheme Modelling in London



TfL is responsible for operating 5% of the roads and all the traffic signals in London. Before talking about modelling, it is useful to give an outline of the legislative framework which regulates that operation, define the terminology used to change it, and describe how the traffic signals are controlled. All traffic modelling is based around the ways the road network currently operates, so some knowledge of this background is important when undertaking any kind of modelling project.

2.1 Legislative Responsibilities

The Traffic Management Act (TMA) 2004, with text updated by virtue of the Infrastructure Act (2015) requirements, places a Network Management Duty (NMD) on all Local Traffic Authorities (LTAs) in England, including TfL and the London boroughs. As London's strategic traffic authority, TfL has both a local and strategic NMD. The NMD requires the LTA to:

- Ensure the expeditious movement of traffic on its own road network; and
- Facilitate the expeditious movement of traffic on the networks of others.

Guidance was produced by the Secretary for State in 2005, but essentially the NMD requires an authority to manage all their activities in such a way as to maximise the efficiency of movement on their road network and minimise unnecessary delay. Each LTA must appoint a Traffic Manager, whose role includes ensuring that the NMD is fully considered and applied throughout all the authority's functions.

TfL's responsibility covers:

- Transport for London Road Network (TLRN), a network of nearly 580km of London's roads (shown in red in **Figure 1**). This makes up 5% of the roads but carries 30% of London's traffic and is the responsibility of TfL under the TMA;
- All of the traffic signals in London, whether they are on the TLRN or not; and
- Strategic Road Network (SRN), comprised of a further 500km of routes which are considered to have a strategic importance in terms of network operation, including major bus routes (shown in pink in **Figure 1**). Boroughs have overall responsibility for these routes, however TfL has operational oversight and has to be notified of activities which will affect, or are likely to affect, them. TfL also has powers to intervene in relation to activities which will affect, or are likely to affect the SRN, where it is necessary to do so.

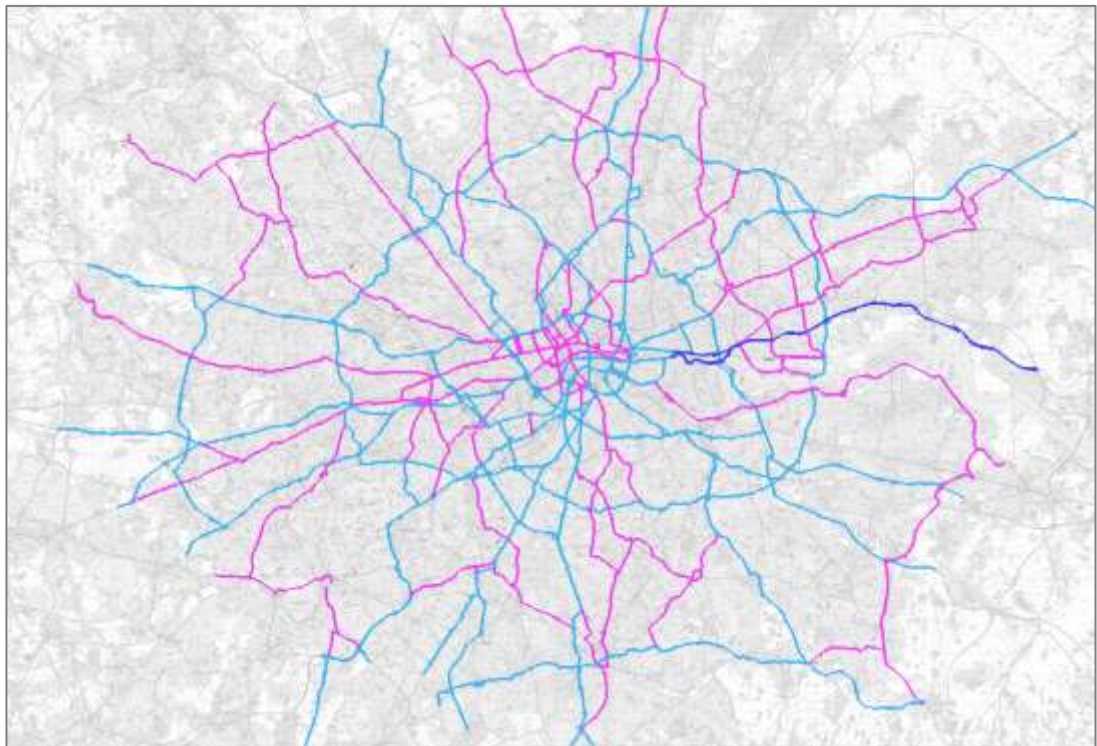

Figure 1: The TLRN (shown in blue) and the SRN in (shown in pink)

Given the proximity of neighbouring road networks in London, and the fact that the TLRN runs through 32 of the 33 London boroughs, the importance of evaluating changes to the highway environment in the context of a broader network is paramount, and modelling is a critical tool by which to do this effectively.

Highway Authorities are also required to make decisions about highway changes in the context of current policies. TfL is responsible for supporting the Mayor of London to deliver their Transport Strategy. The current Mayor's Transport Strategy (MTS)³ was published in March 2018 and is available at <https://tfl.gov.uk/corporate/about-tfl/the-mayors-transport-strategy>. These Guidelines provide specific guidance on modelling for 'sustainable modes', taking into account the expectations of the current MTS in London and wider central Government policies to encourage more walking, cycling and use of public transport to address public health and environmental policies.

2.1.1 Scheme Definition

Before detailing how this NMD relates to TfL and traffic modelling in particular, it is useful to have a working definition of how the word 'scheme' is used in the context of these Guidelines:

A scheme is a planned change to the road network or signal operation at one or more junctions that is intended to improve safety, junction performance or road user experience. The scope may vary from a minor adjustment of signal timings at a single site to a complete redesign of road and junction layouts, and methods of control across a wide area. Schemes may be introduced by a Highway Authority as result of strategic objectives, policy considerations or in response to a private initiative, such as a new supermarket or housing development. Before implementing a scheme the Highway Authority will typically engage with residents and other interested parties, and there may be a requirement for a statutory consultation period (section [A4.6.2](#)).

2.1.2 Applying the Network Management Duty in TfL

Within NM, the Network Impact Specialist Team (NIST) works on behalf of the Traffic Manager to ensure that the NMD has been fully complied with in the development, design and implementation of highway scheme proposals impacting on London's major roads - the TLRN and SRN.

Part of the NMD is to ensure the best possible movement of all modes of transport at signal-controlled junctions in the network. The modes of

3 Mayor's Transport Strategy, Greater London Authority, March 2018

transport that need to be considered are specified by the Department for Transport (DfT) in the order of priority shown in **Figure 2**⁴: In these Guidelines, all these modes of transport are collectively referred to as 'traffic'.

<p>Consider first</p>  <p>Consider last</p>	Pedestrians
	Cyclists
	Public transport users
	Specialist service vehicles (e.g. emergency services, waste, etc.)
	Other motor vehicles

Figure 2: DfT's hierarchy of user provision

When a scheme Promoter proposes temporary or permanent changes that may impact on the operational performance of the TLRN or SRN, that Promoter is required to notify TfL and gain approval through NIST. Additionally, TfL has made it mandatory within its organisation that any proposals developed internally that impact on these same road networks must also be notified and approved through NIST. One of the key benefits of modelling is to support notifications to NIST by quantifying the impact on network performance.

NM provides independent technical support to scheme Promoters, in the form of a Scheme Impact Report (SIR, section **A4.6.1**) to enable NIST to make informed decisions when assessing and reviewing schemes. TfL requires an understanding of the impact of any scheme on bus and cycle journey times, and pedestrian delay at signalised crossings, as well as the impact on journey times for general traffic. This information, which should be derived from models, will be assessed alongside the broader scheme benefits.

2.2 Traffic Signals

In general terms, the control of traffic signals in London (including junctions and pedestrian crossing facilities⁵) can be split into two types: Urban Traffic Control (UTC) and non-UTC. All signalised sites contain basic timings and settings in a controller on-street, however, UTC coordinates the operation of junctions over an area through use of timing plans implemented by a central computer. Non-UTC signals operate under local control, where all timings are stored locally on each controller and activated according to a pre-defined timetable.

The primary function of the UTC system is to transmit stage change events via timing plans to on-street controllers which then adjust the amount of available red and green time for each traffic movement. The majority of UTC-controlled sites are coordinated using Split Cycle Offset Optimisation Technique (SCOOT). Operational systems such as the one used in UTC SCOOT optimise traffic signals using a live data model, and the optimisation method and fundamental principles are similar to those employed by junction design and deterministic models (section [A3.4.1](#)). These operational models are coded and validated manually to ensure that accurate capacity estimates are generated. They commonly use live data inputs from carriageway detectors to make decisions in real time regarding the optimisation of network signal timings. UTC and SCOOT are in the process of being updated and replaced over the next few years.

Non-UTC signal sites are operated by the local controller rather than a centralised system. These facilities are controlled using Cableless Linking Facility (CLF), Microprocessor Optimised Vehicle Actuation (MOVA) or Vehicle Actuation (VA). CLF-controlled sites operate using timing plans stored locally within the controller and, once implemented, timings can only be changed by an engineer on site. MOVA and VA allocate green times to different traffic movements based on vehicle detection between defined minimum and maximum limits. These junctions are usually found in outer London.

Use of the live signal control systems is carried out by NPD and is not covered in these Guidelines, except as a source of data for other forms of modelling and as the ultimate destination for any signal timings that the modelling produces. Whichever method is used to control the signals, all timings will have been through some form of modelling before they are implemented on street.

⁵ Signalised pedestrian crossings in London include: Puffin crossings, Toucan crossings, Pelican crossings (legacy), signal-controlled pedestrian facilities (PEDEX) and equestrian crossings (sometimes known as Pegasus crossings).

3 Modelling Overview



This chapter contains a basic introduction to modelling, including the reasons for carrying out traffic modelling and an overview of the modelling types and processes that are carried out at TfL.

3.1 What is a Model?

Since these Guidelines are concerned with building traffic models, it is appropriate to define what is meant by the term 'model' in its most general form:

“A model can be defined as a simplified representation of a part of the real world ... which concentrates on certain elements considered important for its analysis from a particular point of view.”⁶

It is important to be aware of the simplifications that are made in creating a model and to understand whether they have any significance for the intended analyses.

Simplifications can be made, either deliberately or inadvertently, during model development or calibration, or can be inherent to the particular choice of modelling software used for a project. Model simplifications can be wide ranging and are detailed further in **B2.1.2**. Any model simplification should not diminish the value or quality of the model.

3.2 Why Do Modelling?

Models are designed as simplifications of the real world and used to evaluate the impacts, both negative and positive, of future network and policy interventions. It would be impractical and costly to undertake scheme selection and evaluation in real world environments, so traffic models present a simulated environment in which numerous design solutions can be tested and appraised with the aim of achieving the optimum balance of benefits and value for money.

Modelling can be a powerful tool in understanding the potential traffic impacts of proposals if used in an appropriate way. It can also enable strategies to be developed to mitigate adverse impacts.

To expand on these points, reasons that modelling is both necessary and useful fall into the following areas:

- **Design** – When considering introducing a scheme on the road network, modelling allows for the testing of a variety of options to arrive at a preferred design. Once this has been achieved, the chosen model can also be used for iteration between the design and modelling functions in order to further refine the design to give the optimal operational performance;
- **Balance** – The needs of all road users can be considered and competing demands balanced. The simulated environment can also consider the needs of predicted new users of a facility which does not yet exist, for example customers of a new supermarket or cyclists encouraged by a new cycle lane. This can help to maximise the benefits of a scheme;
- **Prediction** – Models can help to quantify the impacts of a scheme using standard outputs such as flow, journey time and speed changes. They can also highlight stoplines which may have capacity issues in the proposed design so that mitigation measures can be investigated;
- **Communication** – The results of modelling can be used to communicate the predicted effects of a scheme and give stakeholders some idea of how it will look after implementation. Most forms of

modelling have some form of visual output which can be used to clearly convey technical data to a non-technical audience; and

- **Demand** – Models can be used to explore implications of alternative demand resulting from in travel behaviour or the introduction of new mobility technologies.

In addition to these general points, as indicated in section [A2.1.2](#), TfL has a duty to assess the impact of any proposed scheme on the network.

Modelling is a significant part of any assessment and provides information to the SIR. This enables NIST to understand the proposed operation of the scheme and make an informed decision on whether to grant approval.

3.3 Basic Modelling Process

The generalised process for creating traffic models for scheme assessments is described in this section. For most TfL modelling projects this is formalised and expanded in the Three Stage Modelling Process, which is described in section [A3.5](#), however the steps described here will form part of any modelling exercise where there is a defined outcome.

3.3.1 Replicating the Current Situation

The starting point to any modelling project is to build a model that replicates the current traffic conditions at a given point in time, usually when the data used to build it was collected. This model represents a baseline which can be used for comparison with any other scenarios and is called a 'Base' model. A Base model is created for any time period that requires assessment. At a minimum this would usually include AM and PM peaks, but more time periods may be modelled if they are deemed necessary.

Base models are developed and calibrated using data collected on street, and are validated to demonstrate that they have adequately represented the current conditions and are suitable to be used for comparison when assessing other scenarios. Validation is an exercise that involves comparing model outputs with real-world data and showing that they match to within a prescribed level of accuracy. The levels used by TfL for each parameter can be found in MAP, which is described more fully in section [A3.6](#). The data used for validation is also collected on street and should be independent of the build data. The particular parameters that are validated depend on the type of modelling software which is being used. Examples include the degree of saturation (the percentage of capacity that is used) at a stopline and journey times between two points.

3.3.2 Assessing Future Scenarios

Almost all traffic modelling exercises are carried out with the purpose of predicting the operational performance of a proposed future intervention. During the development of future scenario models it is necessary to make assumptions regarding road user behaviour under new proposals, since these cannot be observed or measured in reality. All assumptions made at this stage should be determined following a logical approach and recorded. The approach should draw upon available survey data and observations where possible. Often assumptions will depend on the nature of the scheme proposals, in which case an understanding of the wider project is essential.

These scenario models will be built using the Base model as a starting point and change only those aspects which are a direct result of the proposed design. If the Three Stage Modelling Process applies (section [A3.5](#)) then an intermediate step may be added, to build a future year model where the scheme is not included and accounting for any future demand changes. This is in order to provide a future year basis for comparison when assessing the results.

3.3.3 Interpretation and Presentation of Modelling Results

The model developer is responsible for presenting modelling results. In the case of the Base model the results are used to:

- Demonstrate the model adequately represents the existing situation; and
- Provide the reader with a detailed assessment of the existing situation.

In the case of the proposal, model results should demonstrate the effect and operation of the scheme on the road network. The model developer must ensure that any impact on the road network is presented and the cause for this impact discussed. Results from the modelling should be presented as a comparison with the Base model or, if more appropriate, with a future year Base model to demonstrate the impact of the scheme against a future without the scheme.

In order to inform accurate decision making, the presentation of model results should detail any assumptions made during model development and any influence they have on the reported results.

3.4 Transport Modelling Hierarchy

Transport modelling operates at various levels of detail and scale, from large regions that may cover an entire city or country down to single junctions. The hierarchy in scale of these modelling levels is illustrated below in **Figure 3**:

- Deterministic modelling covers the smallest area, from a single junction to a group of linked junctions;
- Microsimulation modelling covers areas from a few junctions to a whole corridor or town centre; and
- Tactical and Strategic modelling may cover similar spatial areas (for example the whole of Greater London) however tactical models look at shorter timescales and are often cordoned to focus on specific regions, whereas strategic models consider traffic patterns across the city and commuter catchment area up to 30 years ahead.

Data exchange usually operates between different levels of modelling to promote analytical consistency, and is described further in section **A3.4.5**.

3.4.1 Deterministic Modelling

Deterministic modelling, also known as local modelling or junction modelling, can cover areas ranging from a single junction to a group or 'region' of junctions with linked signal timings. This level of modelling focuses in detail on the capacity of individual stoplines and junctions, and the interaction between them. The use of the word deterministic to describe these models relates to the fact that given identical starting conditions the outputs will be the same every time the model is run, meaning the results are pre-determined.

The key feature of deterministic modelling when compared to other types is that it can be used to optimise signal timings. Settings are entered as in on-street junction controllers, so these models can be used for designing and optimising methods of control at junctions and the results can be applied directly. The focus on individual junctions allows quick option testing of modifications to geometric layout and signal staging design, and the interactions between junctions with linked signal timings can also be tested.

3.4.2 Microsimulation Modelling

Microsimulation models can cover an area from a few junctions to an entire corridor or town centre. The size of a model is normally restricted by data requirements and the model run times allowed by current levels of computing capabilities.

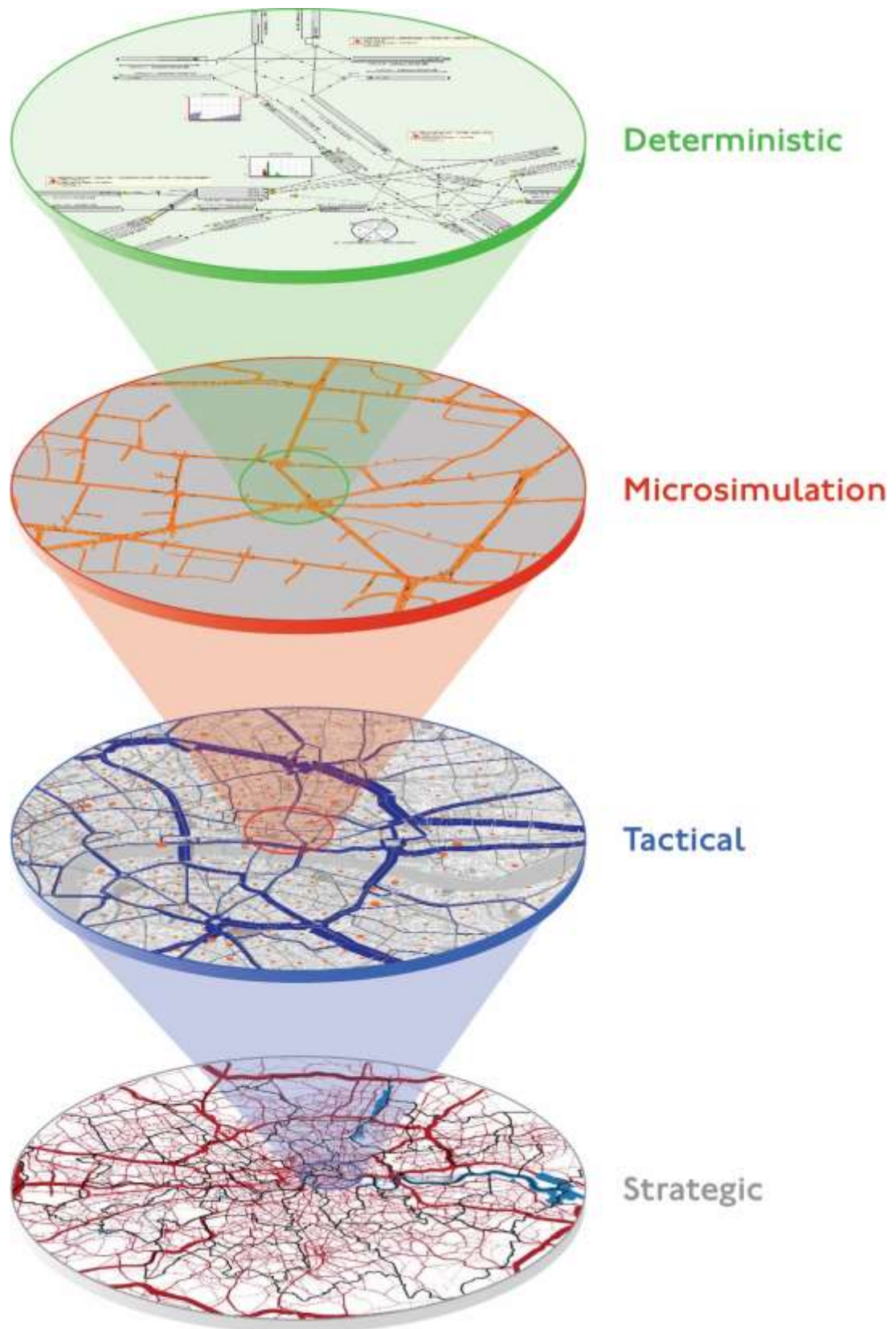

Figure 3: Transport modelling hierarchy

Microsimulation modelling simulates the movements and reactions of individual vehicles, cyclists and pedestrians using behaviour models. It uses randomisation of elements such as vehicle inputs to produce variable model runs which replicate the variability of the real world. The outputs from microsimulation consist of the average of results from a number of model runs.

Due to this modelling of individual vehicles, microsimulation is able to reproduce dynamic phenomena such as queuing behaviour and blocking back through junctions, and the impact of parking or incidents upon the network. It can also represent signal control features such as demand dependency and bus priority using detectors and vehicles / pedestrians in the model.

At TfL, microsimulation models can typically be connected to a simulated version of the same traffic control system which is used to operate the signalised junctions in London. This means that any signal control strategy which can be applied to the street can be accurately modelled, which gives the highest level of realism.

3.4.3 Tactical Modelling

Tactical models consider how vehicles will use the available road network in a relatively short time horizon, predicting up to 5 years ahead⁷. They cover large areas and use aggregated flow values and road / stopline capacities to understand how changes to the road network will affect route choice, speeds and congestion. These models can be used at an early stage in scheme assessment for optioneering and are also used to inform final flow patterns in a chosen design. Mode choice behaviour is not explicitly modelled, however the effect of mode choice can be reflected at tactical level using outputs from strategic travel demand models.

Along with strategic modelling (section [A3.4.4](#)), tactical models are usually built in macroscopic modelling software, which is based on aggregate flows and capacities, as described above. More recently, it has been possible to use a more detailed model than macroscopic, where individual vehicles are simulated but without the complex behaviours and interactions of microsimulation. This type of modelling is called mesoscopic. It is not widely used at TfL at the time of publishing, although its uses are being investigated.

⁷ Shortest term of demand input provided by City Planning is 5 years, which is why M&V tactical models work in 5 year intervals. With any term longer than this confidence levels decrease and is less useful for operational purposes.

The Operational Network Evaluator (ONE) model is a tactical model that is developed and maintained by M&V. It is used to conduct operational assessments to indicate the impact of short-term changes on the network and is usually commissioned to support major development schemes. The model covers Greater London and is used to predict global traffic reassignment and congestion impacts due to local network changes. Assessing the implications of local network changes, such as improvements to junction layout or signal timings, requires detailed transport network representation and assignment methods capable of replicating congestion effects. At the time of publishing, the ONE model represents AM and PM peak periods.

3.4.4 Strategic Travel Demand Modelling

Strategic travel demand models are trip demand models which consider multiple future years, often predicting demand on the road network up to 30 years ahead. They cover a large area, typically a whole city or more, and are informed by models which predict population growth, land use and employment change. In TfL, they are used to support planning and help make key investment decisions.

TfL's strategic demand model, Model of Travel in London (MoTiON), uses economic and travel behaviour assumptions and planned transport investment to forecast the total number of trips made, what mode they will use, their travel times and to determine crowding and congestion. It covers all of Greater London and also has zones across the country to account for trips into and through London. This model is built and used by TfL's City Planning Strategic Analysis team⁸, and so is not covered in detail in these Guidelines. Integrated into MoTiON are the following assignment models:

- London Highway Assignment Model (LoHAM), a traffic assignment model covering the whole of London which models the routes drivers choose and the associated congestion and delay impacts;
- Railplan, a public transport model for predicting the modes and routes customers choose; and
- Cynemon, which predicts cyclist routes and journey times.

Strategic travel demand is modelled at an aggregate level of detail. Traveller demand is usually defined in person trips and is derived from demographic census data, observed trip making behaviour from surveys and, more recently, anonymised mobile phone and vehicle satellite navigation data. The outputs of these models, traffic demand matrices, are passed to tactical models.

8 <http://content.tfl.gov.uk/londons-strategic-transport-models.pdf>

3.4.5 Model Integration

Although each level of modelling can be carried out independently, in practice this is rarely the case when producing models for schemes in London. Information is usually shared between modelling levels in order to inform model development, share data and improve the reliability of the results. This is often an iterative process to ensure consistency in model data across different software platforms. As shown in **Figure 4**, there are a number of interactions involved in most modelling projects. The coloured components represent areas covered in these Guidelines.

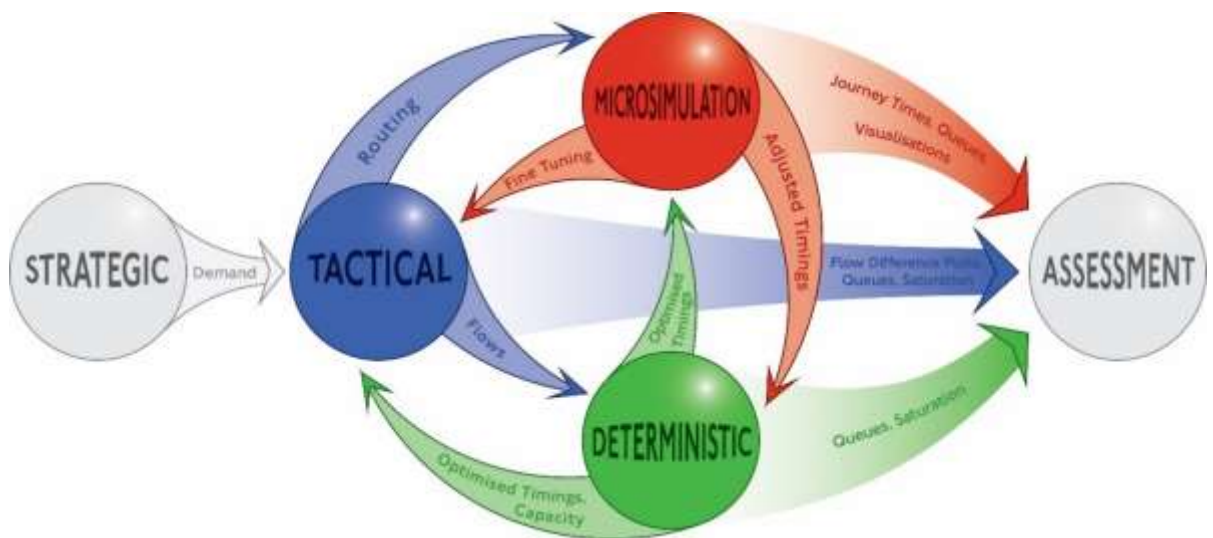

Figure 4: Interactions between different types of modelling



Strategic to Tactical – Strategic travel demand modelling supplies demand, in the form of traffic demand matrices, to tactical models. Usually these matrices do not change during a project, however, the recent emphasis on active travel modes such as cycling has led to increased use of modelling involving shifts between modes. Future scheme modelling may involve an adaptive demand approach where there are significant changes to the network.



Tactical to Deterministic – Tactical models produce flow data for the Future / Proposed scenario. Deterministic junction models are optimised using these flows as inputs. Optimised signal timings and stopline capacities from deterministic models are then fed back to update the tactical model. This iterative process stops when neither flows nor timings change significantly.



Tactical to Microsimulation – Tactical models provide routing information to microsimulation models, usually in both Base and future scenarios, as they produce end-to-end routes which cannot

be observed on street. End-to-end routing is preferred in microsimulation as it allows vehicles to anticipate their route choice at the same point as they would on street which leads to more realistic behaviour on the approaches to junctions. Since microsimulation models involve individual vehicles and data is collected over sections of road, it is easier to see if the routing is causing any obvious problems such as excessive queuing, missing banned turns or anomalous behaviour at gyratories. Any tweaks or refinements can be passed back to improve the tactical model. These are one-time transfers of data and do not usually iterate unless the issues are significant. The aim is to get the best from each model, bearing in mind the differences in software. Significant changes in signal timings can also be fed back from microsimulation to tactical, although these usually come from deterministic models as described above.



Deterministic to Microsimulation – Deterministic and microsimulation models share signal timings. Optimised signal timings are transferred from deterministic models and used as a starting point in microsimulation models. Any adjustments made in the microsimulation models, as well as timings from any traffic management strategies, can be transferred back to deterministic models to derive capacity and saturation results.

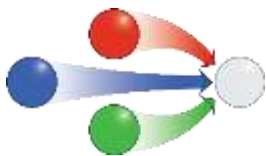

Assessment –Results from the Proposed deterministic, microsimulation and tactical models are compared against the validated Base or Future Base model results to assess the benefits and impacts of a scheme and influence a decision-making process. The modelling results are fully analysed, as appropriate to the level of modelling used, to inform any decision making and design revisions. Where appropriate, this assessment forms part of the SIR (section [A4.6.1](#)).

3.5 Three Stage Modelling

The Three Stage Modelling Process has been developed in order to capture the interaction between modal types and understand impacts such as traffic reassignment due to neighbouring schemes. The process ensures that both the isolated impacts of the schemes and the overall future state of the network are assessed and enables a more complex analysis of the network, focusing on the impact on every journey. The three stages of this process are outlined in **Figure 5**, and they expand and formalise the basic modelling process described in section **A3.3**.

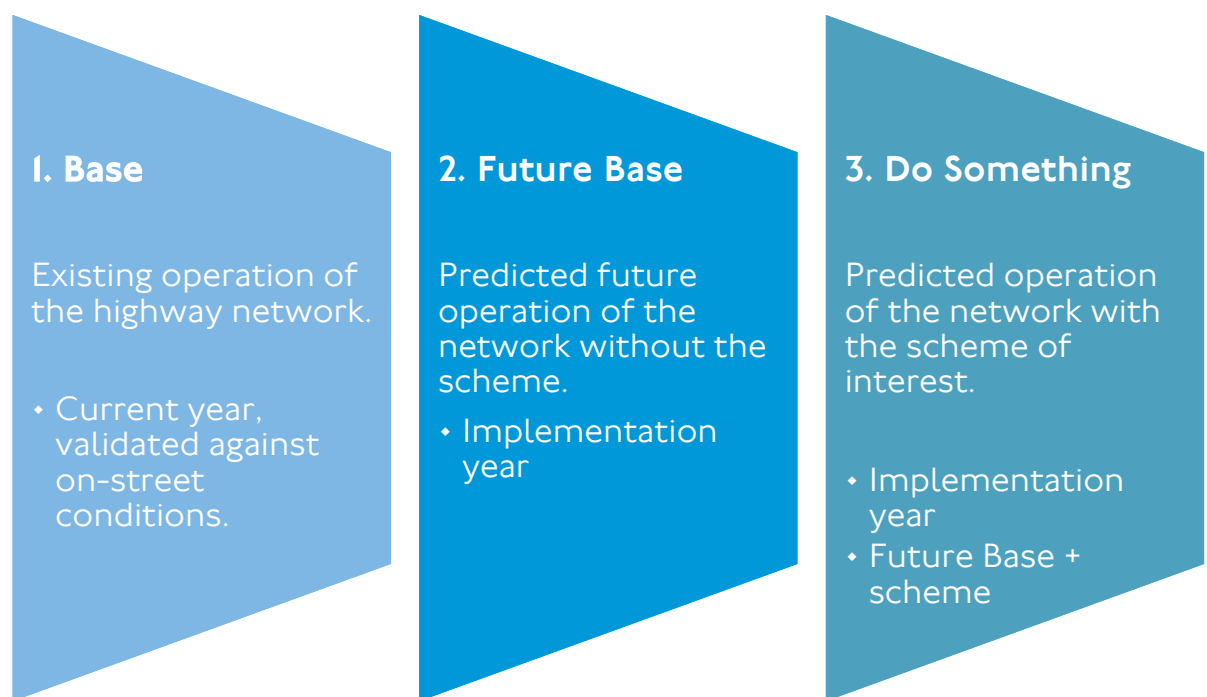

Figure 5: The TfL Three Stage Modelling Process

The Base model is a model that has been demonstrated to represent traffic conditions as observed and measured on street to an acceptable level of accuracy. It should be suitable for use in analysing current network performance and as a benchmark against which other modelling scenarios can be tested.

The Future Base model is developed by altering the Base model to take into account adjacent planned schemes and likely network changes, patterns of traffic growth, a change in road user composition or a number of other interrelated factors that influence the scheme impact footprint. The aim is for this model to represent the future year of scheme implementation without including the scheme under consideration. This is in order to

provide a basis for comparison when assessing the results which is hopefully more meaningful than comparing against the Base model alone.

The final, Do Something, stage is to build the scheme into the Future Base model, changing only those aspects which are a direct result of the proposed design. The isolated impact of the scheme in question can be determined by comparing the Do Something and Future Base scenarios. However, in some instances, it is useful to determine the predicted change from the current situation, and so a comparison between the Do Something and Base results can also be made.

It is recommended that the Three Stage Modelling Process should be used in operational scheme assessments when:

- Traffic reassignment is anticipated as a result of the scheme;
- Traffic reassignment is anticipated as a result of adjacent scheme(s); or
- Network changes occur within the model boundary as a result of other nearby schemes.

This will cover the majority of schemes in London, so it will only rarely be the case that the Three Stage Modelling Process does not apply. The decision as to whether a scheme is to be subject to the Three Stage Modelling Process would occur during the Base model scoping meeting (section [A4.4](#)).

3.6 Modelling Standards

The scheme Promoter is advised to ensure that the person(s) engaged to develop the modelling related to any scheme has appropriate levels of experience. A common cause of poor modelling and analysis is a lack of understanding and experience on behalf of the person producing the model. Any modelling work should be overseen by an experienced modeller who possesses a thorough understanding of modelling concepts and data collection methods, as well as experience of analysing modelling results. Key competencies that are likely to be required include:

- Proven modelling experience with the relevant software and modelling projects, including the different levels of modelling which will be used and the interaction between them;
- Proven experience in on-site data collection of traffic control parameters including saturation flows, degrees of saturation, lane utilisation identification and wasted green measurement;
- A good understanding of the capabilities of signal controllers, particularly with respect to interstage design and phase delays; and
- Experience of modelling signal controllers using modelling software such as LinSig and TRANSYT.

In the particular case where use of the ONE model is required, there is a further constraint. The ONE model is available for use both within TfL, or by a third party. Due to the complex nature of the model it is important that all users are proficient in tactical modelling. As such, each year, interested parties are able to submit their applications to be accredited to use the ONE model. Each of these applications is assessed by M&V and permission to use the model is granted on a case-by-case basis. Applications to use the ONE model come from a range of consultancies and a list of our accredited consultancies can be provided on request from ONE@tfl.gov.uk. Accreditation is an annual process, which occurs at the beginning of each financial year.

Effective traffic modelling requires knowledge and skill on the part of the modeller, and many techniques are acquired through experience or passed on from colleagues. Some of the finer techniques used in traffic modelling are not documented in software manuals, and this is especially true for complex situations where good judgement of available options is required. It is therefore useful to provide modelling guidance, aimed at experienced practitioners, to document tried and tested practical modelling techniques. Traffic modelling for TfL should be conducted according to existing standards of best practice set out in internal and external documents:

- Traffic Modelling Guidelines (this document);

- Model Auditing Process (MAP), also published by TfL and discussed further in the next section; and
- Transport Analysis Guidance (TAG)⁹, published by the DfT.

3.6.1 TfL Standards and Guidance

The TfL Traffic Modelling Guidelines and MAP are complementary documents, as shown in **Figure 6**. They provide a framework to deliver the modelling quality required by TfL, for both Base and Proposed models, from scheme consideration through to a detailed design.

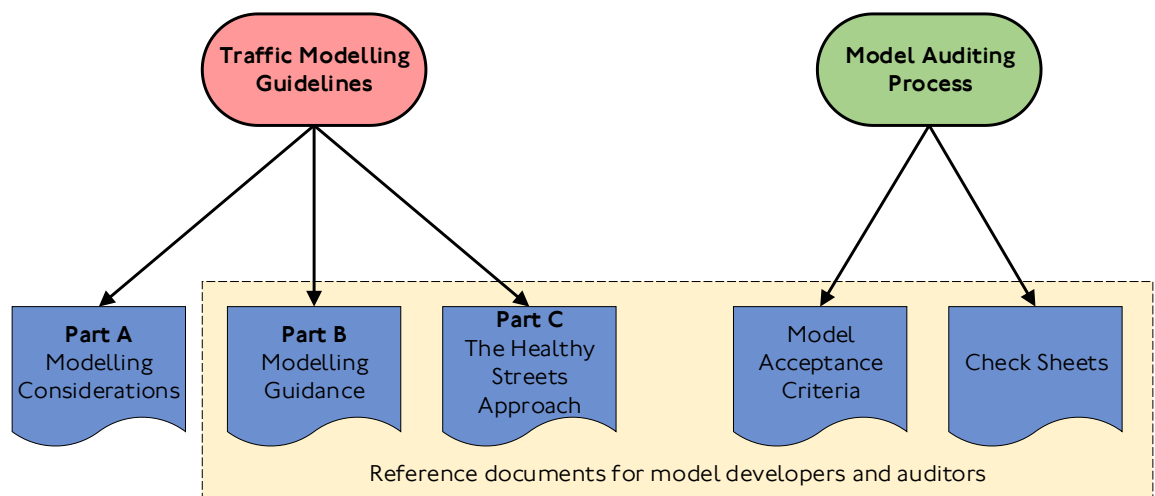

Figure 6: The relationship between the Traffic Modelling Guidelines and MAP

MAP defines the standards expected for all modelling submitted as part of TfL-sponsored schemes. The TfL Traffic Modelling Guidelines indicate recommended ‘best practice’ relating to the approach and methodology of model development in order to reach those standards. In this context MAP provides a structural procedure for auditing models against software-specific modelling standards prior to further phases of development. The TfL Traffic Modelling Guidelines provide overarching guidance on approaches which may be adopted to efficiently meet the standards defined by MAP.

The level of detail and accuracy of a model must reflect the purpose for which the model is intended. The objectives of a scheme will directly influence the type and purpose of any prerequisite modelling.

For a specific scheme, a model may pass through a number of development phases and at each subsequent stage the required level of detail and

⁹ <https://www.gov.uk/guidance/transport-analysis-guidance-tag>

modelling accuracy increases. Common stages of development can be expressed as:

- Outcome definition;
- Feasibility (business case support);
- Concept stage (developing design preference); and
- Detailed design ahead of scheme approval.

It should be noted that not all schemes will be developed to the point where approval is sought, and different schemes will require different levels of detail to support business case development or assessment.

Traffic modelling to support a permanent scheme through NM approval represents the highest level of detail and accuracy required of a model. In general, the modelling guidance presented in **Part B** applies to this highest level of accuracy.

MAP has been developed by TfL in order to ensure consistency in both the production and auditing of traffic modelling. From April 2008 MAP has applied to all TfL-sponsored schemes audited by NP. Full guidance relating to MAP, most recently updated in March 2017, can be obtained from the TfL website¹⁰. MAP sets out the stages which should be followed when submitting traffic models for auditing. The six stages established by MAP are:

- **Stage 1** – Base Scoping Meeting (section **A4.4**);
- **Stage 2** – Calibrated Base Model Submission;
- **Stage 3** – Validated Base Model Submission;
- **Stage 4** – Proposal Scoping Meeting (section **A4.5**);
- **Stage 5** – Proposed Model Submission; and
- **Stage 6** – Submission of SIR to Promoter (section **A4.6.1**).

It also defines a protocol for communication relating to model submission and auditing. Generally, MAP is designed to improve communication and ensure that models are developed to a consistent and high standard so that they progress efficiently through TfL audit with limited, if any, amendments required.

One of the ways MAP facilitates this communication is by the definition of specific roles within the modelling project. These are defined in **Table I** below:

¹⁰ <http://content.tfl.gov.uk/map-v3-5-overview.pdf>

Table 1: Task description for the different parties involved in MAP

Role	Title	Description
Promoter	P	The person responsible for delivering and project managing the proposal.
Design Engineer	DE	The engineer responsible for creating the modelling for the Promoter.
Checking Engineer	CE	The engineer responsible for checking and signing off the Design Engineer's work as fit-for-purpose for the Promoter.
TfL Signals Auditing Engineer	SAE	The TfL engineer responsible for checking and safety approving the proposal.
TfL Model Auditing Engineer	MAE	The TfL engineer responsible for auditing the modelling and assessing the network impact of the scheme.
TfL Network Assurance Engineer	NAE	The TfL operations engineer responsible for assessment, then approval / rejection of the Promoter's proposal (under the TMA).

In summary, the P engages a DE to develop traffic modelling for their proposed scheme. The traffic modelling is internally assessed by a CE, before being submitted to the MAE for auditing.

Standardised check sheets are used for communication between the DE, MAE and SAE during MAP Stages 1 to 5. The SIR provides a summary of the scheme impacts resulting from the modelling assessment.

While NM are accountable for auditing the final scheme models and preparing the SIR (section [A4.6.1](#)), scheme Promoters and their agents (DE and CE) are accountable for ensuring that all scheme models meet the requirements set out within the current version of MAP. Lack of experience on behalf of the DE is a common reason for scheme modelling to not successfully pass through a MAP audit so it is important that the CE role is performed thoroughly.

Failure by the CE to audit a model before submission to TfL may result in unnecessary delay to the scheme programme, due to iterations between the DE and the MAE.

If there is a requirement for a scheme to be audited, that scheme must be registered on the NM Workbook in order that TfL resources for auditing can be assigned. Unfortunately, work cannot be undertaken on any project which is not registered on the NM workbook. For any queries on the process or how to register requirements, contact PPD3rdPartyRequests@tfl.gov.uk.

3.6.2 External Standards and Guidance

DfT's web-based TAG provides information on the role of transport modelling and appraisal. It consists of software tools and guidance on transport modelling and appraisal methods that are applicable to a full range of highway and public transport measures. These enable evidence to be prepared supporting business case development, which inform investment funding decisions. TAG modelling guidance covers subjects such as forecasting future levels of demand and modelling the impacts that a proposal will have on travel choices such as route choice, choice of destination and choice of mode. TAG is focused on options generation, development and evaluation of the subsequent impacts and is distinct from the decision making process. Although TAG may not always be directly applicable to schemes in London, it provides best practice guidance and many of the same standards are carried across into MAP (discussed further in [A3.6.1](#)).

4 Stakeholder Engagement



As outlined in the previous chapter, the aim of these Guidelines, together with MAP, is to provide consistency to a modelling project and to ensure all stakeholders are aware of what is involved. This chapter explains this stakeholder engagement in more detail and outlines what is required at each stage.

4.1 Model Purpose

The one key point that must be considered at the start of any modelling project is:

Why is this model being built?

There may be a number of answers to this, based around the aims of the scheme and any anticipated impacts, but coming up with a comprehensive list of objectives is vital to the success of the modelling. All future conversations and decisions should be built upon this question; and it directly relates to significant choices which must be made early in the project:

- What types of modelling are required?
- What modes of transport need to be modelled?
- To what level of detail?
- What types of data need to be collected?

The answers to these questions will contribute significantly to the timescales that can be applied when putting together the programme for carrying out the work.

4.2 Key Stakeholders

There should be coordination and cooperation between all interested parties in the design of scheme proposals.

All stakeholders should be consulted before undertaking the design of a new highway scheme. It is common that a scheme Promoter will have a particular focus for the outcome and a clearly defined set of benefits, however it is the responsibility of the scheme designer to ensure that all road users are considered.

In addition, the scheme designer should contact all relevant authorities who have jurisdiction over the area being impacted by the scheme to ensure that any concurrent scheme proposals are taken into consideration. The existence of other proposed schemes could impact on traffic flows, junction layout and signal control, so it is important this information is included in the modelling assessment of the area influenced by the scheme.

The interested parties are likely to be: NP and NIST, TfL Engineering Directorate, TfL Buses Directorate, Investment Delivery Planning (IDP, formerly called Sponsorship), the relevant London borough, City Planning Directorate, and Project & Programme Delivery (PPD). Among these, the key stakeholders as far as MAP is concerned are listed in **Table I** in section **A3.6.1**. All of these should be involved at the start to give awareness of the scheme and ensure that they are all clear on the purpose of the modelling.

4.3 Early Design Stages

There are stages of a project design lifecycle that occur prior to creating modelling for MAP approval. The type of project will influence the modelling assessment and project delivery approach, so a broad indication of the stages that may be necessary is included here.

Once the project is addressed and understood, the business outcome is decided and the benefits of undertaking the project are established. Key stakeholders are introduced to the project before any detailed modelling commences, which provides an opportunity for discussions to be held over anticipated difficulties in designing and delivering the scheme.

The feasibility stage is where the proposed outcomes are established, and a decision is made on the achievability of the project's benefits. A variety of options are designed and modelled in this stage, so a single feasible option can be selected. This modelling is usually carried out in deterministic modelling software, as these models are the simplest to build.

Full modelling would be very time consuming and, in some cases, unnecessary for every option, and so deterministic modelling, incorporating the Base traffic flow data, is initially used. Optioneering gives the parties a good understanding of any impacts each option will have on the network, as it demonstrates the changes in capacity at each approach of the impacted junctions. By testing the scheme designs, the model results are interpreted and the designs continually improved through a collaborative effort from the project team.

The options are summarised by assessing the benefits and disadvantages to each transport mode and examining criteria including indicative cost, traffic impact, time to deliver, physical constraints and whether approval is required under the regulatory framework. The modes considered are cyclists, pedestrians, other road users and, particularly, buses.

The optioneering will also aid in fixing the scope of the project, and once the preferred option(s) is decided on, work can move forward to a full Three Stage Modelling assessment and MAP submission.

4.4 Base Scoping Meeting

On initiation of the full modelling works for a scheme, the Promoter or their representative sets up a Base scoping meeting with all parties listed in **Table I**. This meeting is for discussion of the scheme and modelling work that is required for both Base and Proposed modelling stages.

It is recommended that these meetings occur prior to the scheme detailed design being developed. This is to ensure that all TfL information and requirements are known to the Promoter and those they engage to do modelling work prior to development of the scheme. It provides an opportunity for the Promoter's team to record details for future submission and to ensure all parties understand their roles and responsibilities within MAP.

MAP Stage I serves as the Base scoping meeting for modelling projects which are following MAP.

4.4.1 Modelling Scope

A scheme may have an influence beyond the boundaries of the physically modified area. The scheme designer, alongside other contributors to the scoping meeting, is thus responsible for determining the extent of the area of influence. The area to be modelled is determined by the area which is considered to be affected by the scheme proposal. In order to properly assess scheme proposals and deliver a model which is fit for purpose, the modelling must cover this area.

The scheme designer is responsible for ensuring that these wider impacts are considered, discussed and, where appropriate, mitigated and that any mitigation forms part of the scheme proposals.

It is the scheme Promoter's responsibility to assure NIST that the proposed scheme can be appropriately accommodated in the network.

Deciding on the boundary of the modelling work to be undertaken necessarily includes identifying all the signal-controlled junctions which must be modelled. Once these have been finalised it is necessary to determine how they are controlled (section [A2.2](#)) so that the appropriate data can be collected on their method of operation.

It is also necessary to decide on the time periods which need to be modelled. At a minimum this would include the AM and PM peaks, however, depending on the location, other time periods may be required. For example, shopping areas may be busy during the middle of the day or at weekends, and models including the end of the school day may need to start earlier than the traditional PM peak. Decisions should be based on knowledge of the area and should also consider any changes which may be introduced as part of the scheme.

4.4.2 Site Visit and Data Collection

It is not possible to develop a model to the standards required by MAP without conducting appropriate observations for each period being modelled. Site visits are expected to be undertaken.

Models commonly fail a MAP audit due to a lack of familiarity with the site on the part of the model developer. It is therefore essential that the model developer conducts site visits to:

- Familiarise themselves with conditions for all road users at the site and the surrounding environment;
- Confirm that supplied drawings are current and accurate;
- Understand how the junction / network operates in terms of road user behaviour, capacity and safety; and

- Collect accurate data for developing the calibrated model and validating the Base model.

Some of the data required to develop a model can be collected by third-party survey companies, however, certain data such as degrees of saturation should only be collected by an experienced model developer as their accurate representation in a model is essential.

4.4.3 Modelling Expectations Document

To ensure that there is no ambiguity relating to the modelling requirements for a scheme, a Modelling Expectations Document (MED) should be produced following the Base scoping meeting at MAP Stage 1 (section [A3.6.1](#)). The MED summarises the agreed scheme-specific modelling requirements and is agreed by all parties before a scheme can progress through MAP.

The content of the MED will vary in accordance to the scale and purpose of a scheme. Common topics that are included with a MED are:

- Model purpose;
- Model area;
- Peak periods;
- Software requirements;
- Calibration / Validation criteria;
- Data collection;
- Signal data;
- Programme; and
- Contact details.

Scheme proposals may evolve throughout the modelling process. The MED should be reviewed during the Proposal Scoping Meeting, MAP Stage 4 (section [A3.6.1](#)) and updated if any of the modelling requirements have changed.

4.5 Proposal Scoping Meeting

TfL is committed to supporting all scheme Promoters in delivering a successful highway scheme which meets the stated outcomes and benefits. The Proposal Scoping Meeting, which will usually take place once the Base modelling is complete and approved, should involve all previously mentioned stakeholders. The aim is to discuss the scheme proposals and the requirements for Proposed models in order to ensure a high quality and consistent approach to model development. The modelling must clearly demonstrate how outcomes and benefits are achieved and illustrate the impacts. Any changes and developments will be recorded in the MED.

MAP Stage 4 serves as the Proposal Scoping Meeting for modelling projects which are following MAP.

4.5.1 Strategy Considerations for Highway Scheme Development

As indicated in section [A2.1](#), all design decisions must be made taking account of the requirements and objectives set out by the following:

- Mayoral Policy and the current Mayor's Transport Strategy;
- The Network Management Duty as defined in the Traffic Management Act (2004), including any amendments; and
- The strategic and policy requirements of the local highway authority.

TfL's expectation is that proposed scheme impacts on each group of affected road users will be balanced and manageable. NPD will support scheme Promoters to develop designs and mitigate any unacceptable impacts wherever possible. The precise level of impacts deemed acceptable will depend on current policies and network conditions, and will be balanced against the benefits of the scheme to those same road users.

4.5.2 Scheme Design

This section outlines some considerations when designing and modelling junctions and is intended to help less technical audiences understand what might be required to support the design and assessment of any scheme. Relevant standards and documents are also introduced to give an awareness of how and when they are used.

4.5.2.1 Scheme Safety

The safety of all road users is the top priority for TfL and we advocate that all highway schemes should look to improve safety in the scheme outcomes. Changes to the operation of junctions can have significant influence on the safety of all road users.

Safety underpins the whole scheme design and modelling process and is specifically covered as part of MAP and the SIR. The role of the SAE within MAP is to ensure that the proposed junction and crossing designs meet the safety requirements in SQA-0640¹¹, and there is a check sheet to verify that this has been carried out. The SIR contains a section on safety checks which must be carried out by the Engineering Services team. It includes boxes for design approval and reviews on timings, buildability and maintainability, which must all be examined for safety implications before they can be signed off.

SQA-0640 refers to the following series of documents, which are produced by TfL's Engineering directorate:

- SQA-0640 - Policy, Standards and Guidance to Procedures for the Design of Traffic Signals;
- SQA-0641 - High Level Process for the Design of Traffic Signals;
- SQA-0642 - Client Requirements;
- SQA-0643 - Design for Signalised Junctions;
- SQA-0644 - Design for Stand Alone Crossings;
- SQA-0645 - Traffic Signal Timings;
- SQA-0646 - Safety and Design Checking of Signal Schemes;
- SQA-0647 - Justification for Traffic Signals; and
- SQA-0648 - Documentation for the Design File.

These are governed by the Traffic Signs Regulations and General Directions (TSRGD¹²) which is published by the DfT, and the Design Manual for Roads and Bridges (DMRB¹³), Volume 8 – Section TA 84/06 – “Code of Practice for Traffic Control and Information Systems for All Purpose Roads” which is published by National Highways (formerly known as Highways England).

The TSRGD is a UK Statutory Instrument which prescribes the designs and conditions of use for traffic signs, including road markings, traffic signals and pedestrian, cycle and equestrian crossings used on or near roads.

11 *Policy, Standards and Guidance to Procedures for the Design of Traffic Signals*, Specification SQA-0640, Issue 1, Asset Management Directorate, Transport for London, 2016.

12 *Traffic Signs Regulations and General Directions*, Department for Transport, 2016.
<https://www.legislation.gov.uk/ukxi/2016/362/contents/made>

13 *Design Manual for Roads and Bridges*, Highways England, March 2020.
<https://www.standardsforhighways.co.uk/dmrbr/>

Further advice from the DfT on the implementation of the TSRGD can be found in the Traffic Signs Manual (TSM¹⁴), Chapter 6 – “Traffic Control”. This chapter of the TSM contains advice recommended for those designing traffic signal junctions and crossings on roads with a speed limit of 40mph and under, particularly in urban areas.

The DMRB contains information about current standards relating to the design, assessment and operation of motorway and all-purpose trunk roads in the United Kingdom, these are roads with speed limits above 40mph.

4.5.2.2 Junction Layout

The layout of proposed junctions is determined by a wide range of factors. The final design must comply with the appropriate design standards and safety requirements, as described in section **A4.5.2.1** above, whilst also delivering a balanced level of service for all road users within the physical limitations of the site and considering the DfT’s transport priorities (section **A2.1.2**).

Often there will be a number of different junction layouts that comply with design standards and safety requirements. In this situation it is necessary to assess the impact of the different options on network operation, in order to determine which layout delivers the best performance for all road users, in line with the agreed scheme outcomes.

The related SQA document which may be referenced during scheme design is SQA-8448¹⁵ (or its accompanying guidance SQA-0448). This records the safety-critical timings which will be implemented in the controller on street when the junction is installed. Values in this document are dependent on specific features such as precise stopline locations and so will usually need to be updated on any modification of the proposed layout.

4.5.2.3 Network Operation

It is the responsibility of scheme designers to reduce adverse impacts on network operation. Any impacts that cannot be mitigated through design may require implementation of wider network management strategies. TfL should be consulted where it is anticipated that this will be necessary and will work in conjunction with scheme designers to achieve minimal disruption.

-
- 14 Traffic Signs Manual, Chapter 6 – Traffic Control, Department for Transport, Department for Infrastructure (Northern Ireland), Scottish Government, Welsh Government, 2019.
https://assets.publishing.service.gov.uk/government/uploads/system/uploads/attachment_data/file/851465/dft-traffic-signs-manual-Chapter-6.pdf
- 15 Junction Traffic Signal Design Sheet, Specification SQA-8448, Issue 4, Transport for London, 2020

It is necessary to ensure that any scheme design can operate effectively at all times of day. Any issues that may arise outside of the traditionally modelled peak periods should have been highlighted early on in the project (section **A4.4.1**). Consideration should be given to weekend operation, where traffic levels may be similar to a weekday but where capacity may be constrained through the relaxation of parking, waiting and loading restrictions, or where increased levels of pedestrians may require a higher level of service to reduce delays at signalised crossings. Operation of the network overnight is also important, as demand from night-time freight movements is increasing and roadworks are often permitted during the night to reduce disruption at busier times.

4.5.2.4 Design Refinement

The bulk of option testing should have been carried out before the project reaches the full modelling stage that is the focus of these Guidelines (section **A4.3**), however, small tweaks to the design may be necessary once operation in a microsimulation model has been observed. Any of this sort of optioneering will be carried out by the DE and usually only the final design will be submitted for audit.

4.5.3 Public Transport Considerations

It is important that public transport is represented in models, especially where a scheme includes existing or proposed public transport services such as bus or tram routes. It is necessary to consider the impact of public transport on traffic behaviour and network capacity and also for scheme modelling to present the impact of a proposal on public transport performance.

Correct representation of fixed bus routing within a network is important when building an accurate traffic model. Bus timetables¹⁶ and routing maps¹⁷ indicate the frequency of buses and bus type by time of day, additionally bus performance data from systems such as iBus may also be available. This data can be requested from TfL, but any requests must go through a TfL sponsor to ensure the request is valid and formatted correctly.

Depending upon the focus of the scheme, it may be necessary to use observed data to verify that modelled bus journey times are accurately represented. If this is the case, it places constraints on the type of modelling that can be used, as explained in Chapter **A5** on **Which Traffic Modelling Software? Why?**.

¹⁶ <https://tfl.gov.uk/travel-information/timetables/>

¹⁷ <https://tfl.gov.uk/maps/bus>

4.5.4 Pedestrian Considerations

Pedestrian facilities are provided to assist pedestrians in safely crossing the carriageway whilst exercising due care and attention. There are a number of signalised methods for achieving this and which of these methods can be best applied should be considered on a site-by-site basis. In order to assess which method is most applicable it is useful to have knowledge relating to pedestrian flow patterns, vehicular degree of saturation, the topographical layout of the network or junction and the local services and destinations which may play a role in driving pedestrian demand levels at certain times of the day (such as schools, shopping centres or places of worship).

It is necessary to have an understanding of the volume, location and timing of demand from pedestrian movements around the study area and particularly at junctions. This information is useful for accurate modelling and can be provided by surveys of pedestrian movement.

Pedestrian desire lines represent the major pedestrian movements within a network. An understanding of desire lines is useful for the design of junction layouts and signal timing plans and to ensure that any proposed facilities will be used effectively by pedestrians.

Signal timings and crossing points can be designed to allow a smooth progression of pedestrians in the direction of heaviest flow. The direction of pedestrian demand can vary according to the time of day and the day of the week. Pedestrian waiting times should be minimised to prevent overcrowding during peak periods, particularly on central islands within the carriageway.

Pedestrians may be explicitly modelled using specialist modelling software or spreadsheets, or they may be included as part of vehicular traffic models. See Chapter **A5** on **Which Traffic Modelling Software? Why?** and Chapter **C3** on **Pedestrian Modelling**, for further information on the different options available for modelling pedestrians. Specific pedestrian models are particularly useful where proposed changes to land use or public transport provision may result in changes to pedestrian flows. Pedestrian behaviour may be affected by changes in total volume of people or their desired routes. The results from pedestrian modelling can therefore be used to mitigate these issues and assist in designing appropriate signal schemes.

4.5.5 Cyclist Considerations

The number of cyclists in London is growing, especially during peak periods, and in the Congestion Charging Zone it has reached 16% of total vehicle

flow¹⁸. A growth in cycling, and sustainable travel modes in general, has been integral to a succession of Mayor's Transport Strategies. Given the numbers of cyclists on the network in London it is important to consider them in any network assessment.

Any effects of a proposed scheme on cycling (and any growth in cycle demand) need to be carefully considered before selecting the most appropriate software for a modelling project based on the detail required. Particularly in inner London, cyclists should typically be considered in any modelling work unless there is reasonable justification to exclude them.

Schemes are advantageous to cycling if they reduce journey times or delay and help cyclists to maintain a steady speed and a direct course, without interruption or obstruction, from a position where they can be seen by drivers and pedestrians. For this reason, the cyclist user experience can benefit from specialist provisions within a scheme, particularly those incorporating safety considerations. Cyclist safety may be improved through the use of various different infrastructure and signalling techniques, including:

- **Advanced Stop Lines (ASLs)** – these allow cyclists to position themselves in front of queuing traffic so they can remove themselves from conflicts with turning vehicles. If the road layout allows, they can be combined with feeder lanes which allow easy access and safer cyclist progression within the carriageway;
- **Cyclist early start** – these are signals which turn green for cyclists a few seconds before those for general traffic which, again, allows cyclists to avoid conflicts with turning vehicles. They can be smaller, low-level signals or full-size signal heads, depending on the junction layout;
- **Widened carriageways** – which will give vehicles more space to overtake cyclists, reducing conflicts. These can be marked with a cycle lane to encourage vehicles to consider cyclists; and
- **Segregated cycle lanes** – where cyclists are physically separated from traffic by some form of barrier and have their own signals at junctions.

There is an increasingly large network of cycle routes across London, including Cycle Superhighways, Cycleways and Quietways, which should be taken into account when a scheme is planned as it is important that these are not negatively impacted. In schemes where specialist provisions are proposed it is necessary to model the impact that these will have on all road users including public transport.

18 Harryman, M., Traffic Note 3 – TfL Cordon & Screenline Surveys 1971-2018, Transport for London, 2019

Further guidance on cycle design can be found in Chapter 4 of the London Cycling Design Standards (LCDS)¹⁹. LCDS sets out requirements and advice for cycle network planning and for the design of dedicated cycle infrastructure, cycle-friendly streets and cycle parking. This guidance applies to all streets in London and must be adhered to for relevant funding programmes.

Cyclist behaviour and routing is considerably less predictable than for other vehicles and cyclists vary widely in their speed and ability. It is often the case that factors other than cyclists determine which type of modelling will be used in a particular scheme, however, cyclists should always be included in the decision-making process, particularly if the scheme has a cycling focus. See Chapter **A5** on **Which Traffic Modelling Software? Why?** and Chapter **C2** on **Cyclist Modelling**, for further information on the different options available for modelling cyclists.

4.5.6 Emissions Considerations

Motorised traffic produce emissions which include greenhouse gases and air pollutants. Greenhouse gases like CO₂ have little impact on local health but are considered to contribute to global warming. The Climate Change Act details the UK's commitment to be carbon neutral by 2050²⁰. Air pollutants are substances in the air that can harm human health and affect quality of life. The Mayor's London Environment Strategy²¹ details the specific challenges surrounding air quality and the measures which are planned to overcome them. Air pollution causes thousands of Londoners to die sooner than they should (estimated over 9000 Londoners died prematurely from long-term exposure to air pollution in 2010²¹). Children, the elderly and people already suffering from pulmonary or cardiovascular disease are particularly vulnerable. In order to tackle these issues, the London Environment Strategy aims to reduce car use and switch to cleaner fuels to ensure that London's transport system is zero emission by 2050. It also prioritises reduced air pollution at locations such as schools, nurseries, care homes and hospitals.

Road transport contributes significantly to the emission of air pollutants in London²². Pollutants which have an impact on local air quality and human health can broadly be divided into two categories:

19 London Cycling Design Standards – A guide to the design of a better cycling environment, London Cycling Centre of Excellence, Transport for London, 2016

20 <https://lordslibrary.parliament.uk/climate-change-targets-the-road-to-net-zero/>

21 London Environment Strategy, Greater London Authority, May 2018. Can be accessed at <https://www.london.gov.uk/what-we-do/environment/london-environment-strategy>

22 Air Quality Team, *London Atmospheric Emissions Inventory 2016*, Greater London Authority, 2019.

- **Nitrogen dioxide (NO₂)** – NO₂ is mainly formed in the atmosphere from nitric oxide (NO) emitted by road vehicles, but it is also emitted directly. By convention, the sum total of NO and NO₂ is termed 'nitrogen oxides' (NO_x);
- **Airborne particulate matter** – Different classifications are used to describe particulate matter according to their physical characteristics²³, the most common being PM₁₀ and PM_{2.5}; and
- **Carbon Dioxide (CO₂)** – a main greenhouse gas contributing to global warming and climate change.

The two major road-based initiatives that have been introduced are the Low Emission Zone²⁴, which dates from 2008 and covers most of Greater London, and the Ultra Low Emission Zone²⁵ (ULEZ). ULEZ launched in April 2019 covering the area inside the Inner Ring Road and is due to be expanded in October 2021. These zones charge the most polluting vehicles for entering with the aim of removing them from areas with the worst air quality and the London Environment Strategy presents data which shows that air quality is improving overall across London.

Schemes which cover smaller areas can also be investigated for their environmental impact in addition to the typical modelling expectations. Appropriate environmental conditions are central to the effective delivery of any Healthy Streets focused scheme. Walking and Cycling schemes must be delivered in an environment that is conducive to undertaking these activities.

As indicated in Chapter **C4** on **Emissions Modelling**, although air quality cannot be directly modelled due to the large number of factors which affect it, the emissions for vehicles can be estimated. Following a scheme assessment, outputs can be taken from tactical models to be used in an air quality assessment undertaken by specialist environmental consultants. The area considered to be influenced by the scheme may be larger for the environmental assessment than for other traffic models due to wider reassignment of vehicles outside the area of interest, so the area for outputs should be agreed between all parties. The outputs from tactical models for air quality assessments can include number of lanes, link length, link speed, volume of vehicles (broken down by vehicle type) for all sections of road within the agreed area. The specialist environmental consultants are required to factor the peak hour tactical or microsimulation model outputs into 12 hour weekday, and 18 and 24 hour Annual Average Daily Traffic for use in the air quality assessment. If further, more detailed, emissions

23 PM₁₀ and PM_{2.5} relate to particulate matter with a diameter of less than 10µm and 2.5µm respectively.

24 <https://tfl.gov.uk/modes/driving/low-emission-zone>

25 <https://tfl.gov.uk/modes/driving/ultra-low-emission-zone>

modelling is considered necessary then outputs from microsimulation models can be used, as described in Chapter **C4** on **Emissions Modelling**. The common outputs provided are vehicle record files, which include the vehicle type, speed and acceleration for each vehicle every second.

The outputs from the air quality assessments are then used by a Promoter as part of an Environmental Impact Assessment (EIA). An EIA for a relevant highway scheme should consider estimated emissions, traffic, noise and vibration, visual impact and impact on local ecology. Following the submission of an EIA, the local authority or the Secretary of State then determine if consent is given for the scheme to proceed.

4.6 Final Design Stages

NM provides independent technical support to scheme Promoters, in the SIR, to enable NIST to make informed decisions when assessing and reviewing schemes. TfL requires an understanding of the impact of any scheme on bus and cycle journey times, and pedestrian delay at signalised crossings, as well as the impact on journey times for general traffic. Modelling is a significant part of deriving this information and the results will be assessed alongside the broader scheme benefits.

On completion of MAP and the SIR, the modelling results are presented to a formal review panel, where key stakeholders evaluate the delays in the network for each mode as well as assess the impact on the wider network. If successful at the review panel, the project may be presented at public consultation, where possible amendments to the design may be agreed. The results of modelling can be used in the public consultation to communicate the predicted effects of a scheme and give stakeholders some idea of how it will look after implementation.

After a successful public consultation and review panel approval, PPD will begin organising scheme construction. NIST will also be involved during the delivery in accordance with the TMA, as well as NPD, who will manage the traffic signal strategy during construction.

4.6.1 Scheme Impact Report

The Scheme Impact Report (SIR) is used to identify the impact of implementing a scheme on the network. It allows the Promoter to provide all the required information to NIST which enables them to make an informed decision on the project under the TMA. The SIR is completed in the following stages:

- The scheme Promoter initiates the SIR;
- TfL's Engineering Services team will complete the safety checks, including a review of the buildability and maintainability of the design (section [A4.5.2.1](#));
- The SIR is then handed to NPD to inform on the integrity of the modelling and network impact; and
- Once complete, the SIR is handed back to the Promoter who will then submit the scheme to NIST for approval.

The SIR contains a section on model integrity, which details all the modelling work that has been carried out along with any assumptions or exceptions that could affect the conclusions. It also has sections on Walking, Cycling, Bus Network, Freight / Servicing, General Traffic and Taxis,

as all of these modes must be included when considering the impact of a scheme.

An SIR must be completed for all schemes planned for implementation on the TLRN, SRN, and on borough roads if bus operation is also impacted.

4.6.2 Public Consultation

TfL consults the public on a variety of changes to London's transport infrastructure. Some of these consultations are legally required statutory consultations and some are carried out to help the decision-making process by understanding the impact of the scheme on the people affected. Public consultation is mandated wherever proposals significantly affect the road network.

One of the consultation principles, followed by TfL, regarding the provision of information to a public consultation, is stated as:

There is enough information to allow 'intelligent consideration' - the information we provide will be readily accessible, easily interpretable and relevant to the consultation and will be enough to enable consultees to offer an informed response.²⁶

Modelling outputs are often a key part of this information and are usually presented in the form of journey times, separated by mode, from microsimulation modelling. These journey times are the key routes within the model boundary which, if possible, have been validated in the Base model. Tactical and deterministic modelling can provide supporting information, as required. For tactical modelling this would include any predicted rerouting that might impact surrounding areas, and deterministic modelling can provide stopline saturation and any significant signal timings. It is also important to establish any caveats or limitations to the modelling results.

For particularly high-profile schemes, it may also be advisable to include 3D visualisations of the scheme in operation. This is particularly useful to help the public understand the interaction between general traffic, buses, cyclists and pedestrians and to demonstrate any benefits to vulnerable road users.

26 <https://tfl.gov.uk/info-for/boroughs-and-communities/consulting-with-you>

5 Which Traffic Modelling Software? Why?



The most important considerations when deciding on which type of modelling to use and what modelling software would be most suitable are the purpose of the modelling project and the outputs that are required to achieve it. It is also necessary to consider the amount of time and effort that is required for each modelling type to ensure that it is achievable within the scope of the project.

There are a wide variety of software packages available, which vary in their approaches to modelling different traffic situations and behaviours. This chapter aims to provide an estimation of the capabilities of those software packages which are used by TfL and included in the rest of these Guidelines, together with an indication of when it would be appropriate to use them and the timescales that would be required to do so.

The different levels of modelling are outlined in section [A3.4](#), together with an indication of how they might interact if more than one is used. The types of modelling covered are:

- **Deterministic** – including traffic modelling software and spreadsheets;
- **Microsimulation** – including software that models traffic, pedestrians and both together; and
- **Tactical** – including the use of TfL's ONE model.

Table 2 summarises the key points in relation to each type of modelling, and this is expanded on through the rest of the chapter.

In general terms, deterministic modelling is most commonly used for designing and optimising signal-controlled junctions, microsimulation has the best capability to examine complex and busy road networks with variable signal timing strategies, and tactical modelling concentrates on routing and rerouting of vehicles. Most modelling projects will involve some form of deterministic modelling as it will be used to generate the timings which will be implemented on street. The use of microsimulation and/or tactical modelling will be dictated by the needs of the particular scheme that is being modelled and it is often necessary to use a combination of two or more different packages to complete a full scheme design and assessment.

In addition to the types of modelling covered above, a pedestrian-focused scheme, or a scheme in an area with high pedestrian numbers, may require the use of specific pedestrian modelling software or software that has the capability to model the interaction between pedestrians and general traffic at crossing facilities. Using this software, it is possible to estimate the impact of pedestrians on road network performance or the impact of a new traffic scheme on pedestrians. Since this involves simulation of individual pedestrians, it is covered in the microsimulation section below, as well as in Chapter **C3** on **Pedestrian Modelling**.

Also considered in the microsimulation section is emissions modelling. This is because the type of emissions modelling covered in these Guidelines (Chapter **C4** on **Emissions Modelling**) makes use of the second-by-second outputs for individual vehicles which can only be generated by microsimulation models.

The software packages that are detailed in this chapter are those that have been approved for use at TfL after an open competitive procurement process to ensure our modelling software requirements are met.

Table 2: Key features of the different levels of modelling

Modelling	Software	Pros	Cons	Outputs	Timescale / Cost
Deterministic	<ul style="list-style-type: none"> • LinSig • TRANSYT • ARCADY • PICADY • Junctions • Spreadsheets 	<ul style="list-style-type: none"> • Optimisation of signal timings • Similarity to Controller Specifications • First point of call • Quick and easy – good for optioneering • Immediate results 	<ul style="list-style-type: none"> • Limited ability to model different modes • Cannot model wider traffic reassignment • Aggregate flows • Limited ability to model blocking back • Based on average signal timings (demand dependency not directly modelled) 	<ul style="list-style-type: none"> • Degree of saturation • Queue length • Stops and Delay • Signal timings for other types of modelling 	<ul style="list-style-type: none"> • Quick to build (~days) • Quick to run (~seconds) • Low cost
Microsimulation	<ul style="list-style-type: none"> • Aimsun Next • Vissim • LEGION • Viswalk • EnViVer • PHEM 	<ul style="list-style-type: none"> • Models and outputs different modes • Realistic modelling of behaviour • Graphic outputs • Variability included in terms of flows / signals (randomness) • More accurate representation of signal timing (demand dependency, SCOOT, bus priority) 	<ul style="list-style-type: none"> • Time consuming to build and validate • Large data requirements • More expertise needed • Limited treatment of route choice, typically requires use of tactical models 	<ul style="list-style-type: none"> • Journey times • Graphical outputs • 3D simulation • Heat maps (both pedestrians and vehicles) • Vehicle record files • Detailed outputs suitable for local area emissions calculations (EIA) 	<ul style="list-style-type: none"> • Slow to build (~months) • Run overnight (~hours) • High cost

		<ul style="list-style-type: none"> • Models congestion and blocking back impacts 	<ul style="list-style-type: none"> • Auditing process more detailed (additional MAP stage) 	<ul style="list-style-type: none"> • Detailed vehicle movements for use by emissions modelling software • Emission maps 	
Tactical	<ul style="list-style-type: none"> • Aimsun Next • SATURN • Visum 	<ul style="list-style-type: none"> • Models traffic reassignment • Quick tests on road closures • Highlights potential rat runs • Includes impact of multiple schemes which aren't yet on street • Can use the same model for multiple schemes (subject to Base review) 	<ul style="list-style-type: none"> • Model runs typically 48hrs plus • Aggregate flow • Use only average signal timings • Time consuming to build and validate • Do not model pedestrians • Cycling is typically poorly modelled 	<ul style="list-style-type: none"> • Flow difference plots • Network statistics • Outputs suitable for wider area emissions calculations (EIA) • Bus impacts (high level) • Routing information for microsimulation models 	<ul style="list-style-type: none"> • Initial build slow (~many months) • Updates for scheme (~weeks) • Slow to run (~days) • Higher cost

5.1 Deterministic Models

Deterministic models utilise empirical algorithms to calculate the performance of junction designs and the optimal signal settings based on fixed traffic and layout inputs. Deterministic traffic models calculate optimum signal timings based on fixed flows and capacities. This level of modelling focuses in detail on the capacity of individual stoplines and junctions, and the interaction between them. The use of the word deterministic to describe these models relates to the fact that given identical starting conditions the outputs will be the same every time the model is run. Model inputs vary by software but serve to represent the traffic network and its underlying operation, for example by defining geometric details and traffic flow.

A deterministic model is most suited for optimising the coordination of traffic signals to minimise vehicle delay. Deterministic models can estimate the potential performance of a junction or network and allow for option testing of different signal timing strategies. Outputs from these models can provide a general indication on whether a proposal will operate comfortably within the capacity of a road network.

In congested urban areas it is necessary to coordinate the movement of traffic in order to ensure reliable, repeatable performance. The efficient control of vehicles in a network is usually promoted through the use of coordinated traffic signals. The most efficient traffic control strategy for an area will be defined by the most effective way to achieve the outcomes and benefits of the scheme, whilst avoiding significant detriment to any type of road user (section [B2.5.3](#)). The optimum settings for coordinated control will typically vary according to time of day and day of week and they are usually derived from deterministic models.

Deterministic models are generally unable to provide detailed representation of more complex situations such as vehicle merging, junction exit-blocking, traffic reassignment, or the dynamic operation of demand-dependent stages. Although some complex situations can be emulated within deterministic models via the adjustments of vehicle inputs other modelling software may be more appropriate for example microsimulation modelling (section [A5.2](#)) or tactical modelling (section [A5.3](#)).

The approved design and modelling tools for individual and networks of signalised junctions are LinSig and TRANSYT, which can be used to quickly assess the method by which traffic is controlled. Basic models can be built

with only minimal input data, making these tools particularly suitable for preliminary design.

The second category of models that falls within the scope of deterministic modelling is that of unsignalised or priority junctions and roundabouts. Unsignalised control takes place where traffic on a minor movement gives way to traffic on a major movement through the use of signs or markings on the carriageway. The visibility and geometry of a junction both influence the ability of traffic on the minor movement to progress while giving way to the major movement. Schemes which include unsignalised junctions and roundabouts can be modelled with software such asTRL's Junctions, PICADY and ARCADY.

The final type of modelling that should be mentioned is the modelling carried out in spreadsheets. Many forms of data analysis can be performed in spreadsheets, however the ones that are relevant to these Guidelines are used for assessing pedestrian impacts when detailed pedestrian modelling is not required.

5.1.1 Signalised Networks

Deterministic modelling of signalised networks is the most common type of modelling carried out in Network Performance, and the two main software packages used are LinSig and TRANSYT.

5.1.1.1 LinSig

LinSig, developed by JCT Consultancy Ltd (JCT)²⁷, can be used for detailed junction design, assessment of scheme proposals and the creation of 'skeleton' models for checking against junction Controller Specifications. It combines geometric layout, traffic and controller modelling to ensure that it accurately reflects the way existing junctions work, and how any design proposals would operate if implemented.

LinSig provides the functionality to maximise the efficiency of interstage design and is capable of optimising signal timings to either minimise delay or maximise the spare capacity (known as Practical Reserve Capacity, or PRC) of junctions. Signal timings can be manually adjusted to refine the timings or to match site specific safety requirements. Additionally, there is a cycle time optimiser which allows selection of an optimum cycle time by showing how delay and capacity vary against cycle time increments.

As well as individual junction design, LinSig can model and optimise networks of multiple junctions with separate controllers. The optimisation

criteria of delay and PRC can be applied to the network as a whole or to individual junctions. LinSig may also be used to model give-way junctions, albeit with constrained functionality and as part of a wider network.

The most common performance outputs from LinSig models are degree of saturation (DoS) and queue length, which can be used to evaluate if a junction, and therefore the immediate surrounding road network, can operate effectively with the new scheme. Other graphic outputs are available within this software, such as the Cyclic Flow Profile graph shown in **Figure 7**, which can be used to analyse where in the cycle most vehicles arrive at a stopline.

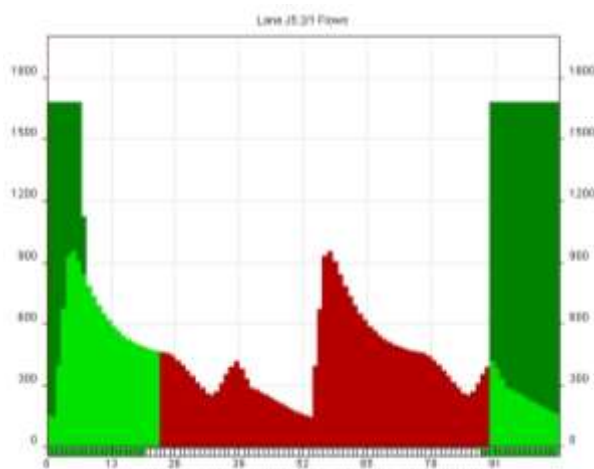

Figure 7: Cyclic Flow Profile graph, showing previously delayed vehicles (dark green), vehicles arriving on green (light green) and vehicles arriving on a red signal (red)

An advantage to using LinSig is the similarity of its interface to junction Controller Specifications, which makes it easy to input data and to transfer timings onto street. LinSig has the ability to optimise junctions and networks for different traffic scenarios, so it is useful for optioneering. Models are quick to build, and the results are available immediately. Conversely, it has minimal capability to model different modes and blocking back and it cannot simulate phenomena such as wider traffic rerouting. It uses aggregated flows and signal timings so the randomness of real life, in particular demand dependency, is not directly replicated.

5.1.1.2 TRANSYT

TRANSYT, developed by TRL²⁸, is used for the optimisation of signal timings, predominantly across coordinated networks of primarily signalised neighbouring junctions. It is capable of estimating optimum signal timings for representative traffic conditions within a network. TRANSYT optimisation is conducted using algorithms which attempt to find optimal signal settings that minimise stops and delay in the network. TRANSYT can be used to model a wide variety of networks, from unsignalised junctions to signalised roundabouts. It is used for impact assessment of proposed schemes and for the initial preparation of signal timing plans prior to implementation.

The most common performance outputs from TRANSYT models are degree of saturation (DoS) and queue length, which can be used to evaluate if a junction, and therefore the immediate surrounding road network, can operate effectively with the new scheme. Other graphic outputs are available within this software, such as the Cyclic Flow Profile graph shown in **Figure 8**, which can be used to analyse where in the cycle most vehicles arrive at a stopline. It can also display performance metrics for assessment using indicators such as capacity utilisation and queue prediction.

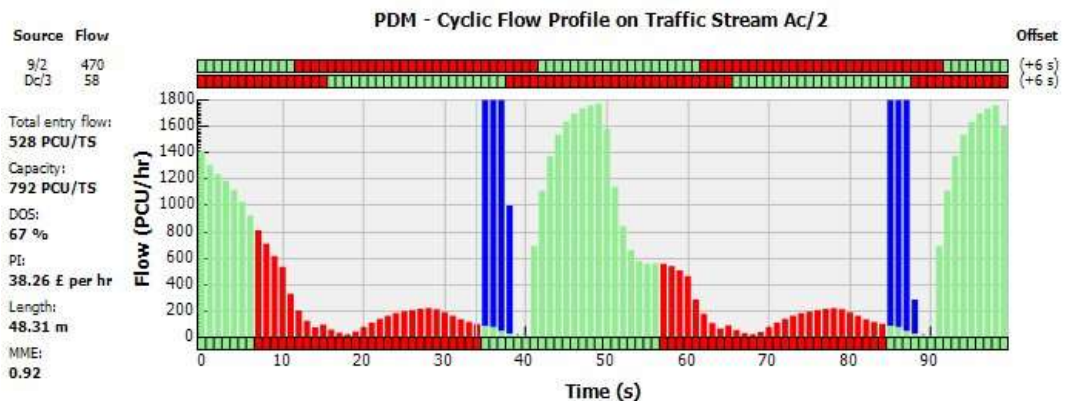

Figure 8: Cyclic Flow Profile graph, showing previously delayed vehicles (blue), vehicles arriving on green (green) and vehicles arriving on a red signal (red)

TRANSYT has the ability to optimise junctions and networks for different traffic scenarios, so it is useful during optioneering. Models are quick to build, and the results are available immediately. Conversely, more recent versions of the software have limited capability to model different modes and blocking back and has capability to model priority junctions beyond standard give-way coefficients. It cannot simulate phenomena such as

wider traffic rerouting. It uses aggregated flows and signal timings so the randomness of real life, in particular demand dependency, is not directly replicated.

5.1.2 Priority Junctions

PICADY can be used to estimate the performance of a unsignalised isolated junction in terms of potential queue lengths and vehicle delays. The software incorporates TRL research to encapsulate the influence of junction design upon driver behaviour and visibility at priority intersections with specific geometric characteristics. It can also model zebra crossings on the approaches to priority junctions.

ARCADY is a tool used to assess unsignalised roundabouts and can model most types of roundabout to predict accident rates, performance and delay to traffic. Like PICADY, it can also model zebra crossings on the roundabout approaches.

As well as being separate pieces of software, PICADY and ARCADY are packaged together in the Junctions application. Unlike the individual software packages, Junctions can be used to model a network of priority junctions and/or roundabouts. In addition, the latest TRANSYT modelling suite allows for limited-functionality PICADY and ARCADY objects to be included within a TRANSYT model, this excludes the modelling of zebra crossings. ARCADY, PICADY, Junctions and TRANSYT are all developed by TRL²⁹.

The most common outputs from these applications are the ratio of flow to capacity for any movement (the unsignalised equivalent of degree of saturation), queue lengths and delay statistics.

The advantages of these software packages are that they are quick and easy to use, and the results are available immediately. Also, they are specifically designed to model priority junctions and so consider more features of the road's geometry than other deterministic software. Conversely, they cannot model different modes or phenomena such as traffic rerouting and blocking back. In addition, they need multiple days of queue data to validate against.

5.1.3 Pedestrian Modelling

The main uses of deterministic pedestrian modelling are for walking and wait times as well as the level of comfort attained in the area.

Spreadsheets that have been developed and are in use at TfL for looking at

29 <https://www.trl.co.uk/>

different aspects of the pedestrian experience. These are applied at schemes where it has been decided that full pedestrian modelling is not necessary or possible. The spreadsheets are explained in more detail in Chapter **C3** on **Pedestrian Modelling**.

The main measure for the pedestrian experience of a scheme is the Pedestrian Comfort Level (PCL) which classifies the level of comfort based on the level of crowding a pedestrian experiences on the street. In the spreadsheet, geometric features of a pavement or crossing are used to derive a value in pedestrians per metre per minute. This is converted into a level, based on a scale from PCL A, which means pedestrians have a lot of space, to PCLs D and E, where pedestrians have little space and their movement is restricted. Whether these levels are considered acceptable or not depends on the type of area being assessed, for example, a retail area such as a high street would become uncomfortable at a lower PCL than a transport hub.

Another spreadsheet for measuring pedestrian performance is used to calculate the delay experienced when travelling across a series of crossings, for example, where there are separate crossings across the entry and exit movements of one arm of a junction. This spreadsheet uses the signal timings and crossing widths to calculate how long a pedestrian arriving at each second of the signal cycle would have to wait at each crossing and uses this to derive an average wait time.

The advantage of using spreadsheets over more complex pedestrian modelling software is that they are much quicker to use. The data requirement is usually only based around the geometric attributes of the area which are readily available in scheme design drawings and so do not involve complex and time-consuming surveys. Conversely, pedestrian behaviour may involve some complex interactions which cannot be conveyed by the spreadsheets.

5.2 Microsimulation Models

Microsimulation modelling simulates the movements and reactions of individual vehicles, cyclists and pedestrians using behaviour models. As a result, microsimulation modelling is able to reproduce dynamic phenomena such as queuing behaviour and blocking back through junctions, and the impact of parking or incidents upon the network.

Microsimulation models are useful when modelling heavily congested conditions where a network suffers poor performance due to excess queuing from neighbouring junctions. In order to represent the different characteristics of drivers, vehicles and pedestrians, microsimulation models perform multiple model runs based on random seeds. This approach seeks to replicate the variability of the real world and helps to highlight any possible performance issues that may be caused by short-lived spikes or disruptions in traffic flow.

The outputs from microsimulation consist of the average of results from a number of model runs, however, individual runs can also be studied since runs with the same seed are repeatable. In networks where significant congestion is expected, microsimulation models are needed to model detailed vehicle behaviour and compliment deterministic model outputs.

Microsimulation can represent signal control features such as demand dependency and bus priority using detectors and vehicles / pedestrians in the model. Depending on the software, microsimulation models can also replicate the detailed behaviour of London's UTC and SCOOT traffic control systems (section [A2.2](#)), so that simulated vehicles and pedestrians can alter the modelled signal timings in the same way as they would on street.

In addition, microsimulation packages are capable of generating animations of the individual vehicles moving within a network and they can produce output files which are used in 3D modelling software to generate high-quality visualisations. As a result, microsimulation modelling can provide a useful visual aid when presenting the performance of complex scheme designs to a non-technical audience.

The disadvantages of microsimulation are that their development and validation is very time consuming, require extensive data collection and considerable modelling experience. Microsimulation models normally rely on tactical modelling for routing information and they typically cannot optimise signal timings. In terms of model run times, depending on the size and complexity of the model, it could take anywhere between 5 and 30 minutes to complete an hour of simulated time. This means that

conducting a full set of 20 seed runs, required to produce average results, would usually be done overnight.

Other, less obvious, issues are that the models tend to be taken as precise predictions of the future, since the viewer can see the 'vehicles' moving. It should be recognised that the best model in the world is still 'just' a model and not the same as real life. It is intended to provide an indication of future performance rather than an exact prediction.

The two vehicle-based microsimulation software packages covered here are Aimsun Next and Vissim.

Modelling the interactions between individual pedestrians is also undertaken using microsimulation and these interactions are generally more complex than modelling traffic. This is because pedestrians have degrees of freedom not enjoyed by traffic: they are not restricted to travel in lanes and can, within reason, move where they like. The two pedestrian microsimulation software packages covered in these Guidelines are LEGION and Viswalk.

Finally, emissions modelling is included in the microsimulation section as it relies on the outputs from microsimulation modelling. The two software packages covered in these Guidelines are EnViVer and PHEM.

5.2.1 Traffic

Microsimulation packages generally do not have the ability to optimise traffic signal settings without external tools, therefore deterministic modelling is commonly used in conjunction with microsimulation modelling. The boundary of a microsimulation model should encompass the extent of the impact of the scheme. If this is not possible a larger tactical model maybe required.

Journey times are the main outputs that are used from microsimulation modelling. These will have been identified as significant routes that are long enough for the results to be meaningful and short enough that a reasonable number of vehicles complete them. The results are usually split by mode and used to compare different scenarios. Heatmaps can be used to display results such as delays, speeds, flows and queue lengths. Most of the data can be exported as a database or text file for use in other software. One of the main benefits of microsimulation models is the ability to visualise detailed vehicle behaviour, overall network performance and the effects of congestion.

5.2.1.1 Aimsun Next

Aimsun Next is transport modelling software produced by Aimsun SLU³⁰ (Aimsun), which is a subsidiary of Siemens Mobility. It is a fully integrated application which includes microsimulation, mesoscopic, macroscopic and travel demand modelling. It also has the capability to combine these in two hybrid simulators: micro-meso and macro-meso. Only the microsimulation aspect of Aimsun Next is considered in detail in these Guidelines.

Aimsun Next microsimulation uses a Lane-Based network layout and a car-following model to reflect the way vehicles move through junctions and roads and interact with each other. The latest version includes integrated pedestrians and has started to include a lateral behaviour model for cyclists. At a basic level Aimsun Next is capable of modelling fixed signal timings and simple responses to vehicle and pedestrian demands. More complex signal behaviour can be manually coded through use of custom written scripts. At the time of publishing there is no simulated version of UTC that works with Aimsun Next, however it is planned that future versions of UTC will have Aimsun Next integration.

Aimsun Next can be used to model complex and congested traffic networks, where deterministic modelling cannot provide a realistic representation. In common with other microsimulation software, it is unable to optimise signal timings, and so is usually used in conjunction with deterministic modelling when looking at proposed schemes.

5.2.1.2 Vissim

Vissim is microsimulation software produced by Planung Transport Verkehr AG³¹ (PTV) for modelling traffic in urban areas. Vissim uses a Lane-Based network layout and a car-following model to accurately reflect the way vehicles move through junctions and roads and interact with each other. It also has the capacity for lateral behaviour within lanes, which makes modelling features such as cyclists and overtaking possible.

At a basic level Vissim is capable of modelling fixed signal timings and simple responses to vehicle and pedestrian demands. More complex signal behaviour can be manually coded through use of custom written scripts. The UTC-Vissim Interface has also been developed, which allows signals to be controlled using a simulated version of TfL's UTC system within Vissim.

³⁰ <https://www.aimsun.com/aimsun-next/>

³¹ <https://www.ptvgroup.com/en/solutions/products/ptv-vissim/>

This allows modelling of real time signal optimisation and advanced signal control strategies such as bus priority.

A further benefit is that the pedestrian modelling package Viswalk (section [A5.2.2.2](#)) is integrated with Vissim, so pedestrian and vehicle interactions can be investigated.

Vissim is typically used to model complex and congested traffic networks, where deterministic modelling cannot provide a sufficiently realistic representation. In common with other microsimulation software, it is unable to optimise signal timings, and so is usually used in conjunction with deterministic modelling when looking at proposed schemes. When the UTC-Vissim Interface is used, signal timings are optimised dynamically by the SCOOT model, however deterministic modelling is still used to provide overall optimal timings.

5.2.2 Pedestrians

Microsimulation pedestrian modelling is useful for schemes with a pedestrian focus, such as a new pedestrianised area; where there is a high volume of pedestrians, such as a high street or outside a station; or where a traffic scheme is predicted to have a significant impact on pedestrian movements. It can provide more insights into how pedestrians will experience the scheme than the spreadsheets covered in section [A5.1.3](#), since it involves simulating individual pedestrians and how they interact with each other. Different types of pedestrians can be modelled, for example men, women, tourists and commuters. These can be given different speeds and routing based on research and data collected on site. For example, tourists with suitcases take up more space and are likely to move more slowly than commuters who travel to the area every day.

The outputs from pedestrian modelling include pedestrian level of service (LoS, similar to pedestrian comfort levels mentioned in section [A5.1.3](#)) and journey times, only based on the 3D densities and movements of pedestrian entities rather than a spreadsheet calculation. LoS can be displayed in the form of heat maps, as can data such as walking speed and space utilisation. Pedestrian journey times can also be assigned a monetary value, or social cost, which is weighted based on the pedestrian activity and allows comparisons between different layouts and options. Pedestrian modelling software also has the capability to export animations or output files which can be turned into 3D visualisations.

As with all microsimulation models, pedestrian modelling provides more detailed analysis at the cost of greater data requirements and longer development and run times.

5.2.2.1 LEGION

LEGION is pedestrian modelling software produced by Bentley³² which represents pedestrians as adaptive agents and treats pedestrian movement as a multi-agent complex system. The interactions between individual pedestrians lead to crowd behaviour emerging naturally rather than being explicitly modelled. LEGION uses inputs, along with other types of object such as drift zones and direction modifiers, in order to best represent pedestrian movement and interaction in the modelled area. LEGION has been used for many years by London Underground to model passenger behaviour in stations and is also often used to model high-profile surface schemes.

LEGION cannot explicitly model adaptive signalised junctions or crossings. Signal control is simulated using waiting zones, where pedestrians are stationary for a defined and fixed period of time, so adaptive timings are not possible. In addition, LEGION does not include vehicles and so cannot predict situations where vehicles may affect pedestrian movements or vice versa.

5.2.2.2 Viswalk

Viswalk, developed by PTV³³, particularly models pedestrians in urban areas. Pedestrian movement in Viswalk is built on a 'social force' model, so movement is based on forces assumed to be exerted by pedestrians and obstacles. Viswalk uses inputs in order to best represent pedestrian movement and interaction in the modelled area. The key benefit of Viswalk over other pedestrian modelling software is that it is integrated seamlessly within Vissim, so it can take advantage of all Vissim's signal control capabilities and investigate the impact of interactions between vehicles and pedestrians. TfL's use of Viswalk is relatively new.

5.2.3 Emissions

The most widely used approach to estimate road traffic emissions is based on the type of vehicle and its average speed on a section of road (section [A4.5.6](#)), this approach can be used with outputs from deterministic or tactical models. However, emissions are very dependent on a number of context and environmental factors and are significantly higher during acceleration compared to cruising. This means that a more granular approach to vehicle and movement is needed, namely second-by-second data for each individual vehicle and location. The use of average flows will

³² <https://www.bentley.com/en/products/brands/legion>

³³ <https://www.ptvgroup.com/en/solutions/products/ptv-viswalk/>

not enable an accurate estimation of emissions in an urban environment, where a lot of stop-start actions take place. In such areas, emissions modelling based on the instantaneous properties of vehicles (type, speed, acceleration and gradient, for example) should be captured.

Microsimulation traffic models are needed to provide the detailed individual vehicle outputs used by the instantaneous emissions model. These outputs can be processed by various emissions software packages which are based around vehicle performance and engine standards. The two software packages covered in these Guidelines are EnViVer and PHEM.

5.2.3.1 EnViVer

EnViVer (Environmental Vissim-VERSIT+ simulations) is an emissions modelling software package specifically designed to calculate emissions based on the simulated traffic data from Vissim (although other software can be used if the output files are adjusted appropriately). It is developed by TNO (the Organisation for Applied Scientific Research) in the Netherlands³⁴. The vehicle emissions calculation in EnViVer works on individual vehicle data with a one-second frequency, such as that from microsimulation models.

EnViVer allows users to define their own vehicle fleet models by configuring fuel type, vehicle age distribution and Euro engine classification standard proportions so that the emissions calculations can be estimated based on local data. EnViVer also has batch processing and post-processing functionality which can be used to calculate, analyse and compare results for multiple different traffic scenarios.

5.2.3.2 PHEM

PHEM (Passenger car and Heavy duty Emission Model) is an emissions modelling software package developed by Technical University of Graz (TUG)³⁵ for calculating vehicle emissions. PHEM calculates the emissions of vehicles on the basis of their speed and acceleration / deceleration rates using individual vehicle data with a one-second frequency, such as that from microsimulation models.

The model calculates the engine power output and engine speed from vehicle positions, speeds and accelerations, so any driving condition can be modelled as long as the vehicle record files are available. The simulation of different vehicle payloads in combination with road gradients, variable

³⁴ <https://www.tno.nl>

³⁵ <https://www.tugraz.at/en/home/>

speeds and accelerations can be modelled replicating the different gear-shifting behaviour of drivers.

PHEM includes an extensive database of previously measured vehicles and engines for the calculation of road traffic emissions, however emissions levels can also be modelled for other types if the vehicle specifications are provided.

5.3 Tactical Models

Tactical models are used to explore how vehicles will use the available road network in a relatively short time horizon, predicting up to 5 years ahead. They typically cover large areas and use aggregated flow values and road / stopline capacities to understand how changes to the road network will affect route choice, speeds and congestion. These models can be used at an early stage in scheme assessments as part of an optioneering process and are also used to inform final flow patterns in a chosen design. Mode choice behaviour is not explicitly modelled, however, the effect of mode choice can be reflected at tactical level using outputs from travel demand models.

The tactical models used for modelling schemes in London will be based on pre-existing models, such as the ONE model, that cover the whole of London. This is because building a validated tactical model has extremely large time and data requirements. Use of existing models will usually involve a 'Base review' to ensure that the area of interest in the model is up-to-date and has any relevant proposed schemes coded in.

Tactical models can output flow difference plots, network statistics, outputs suitable for wider area emission calculations used in EIAs, and high-level bus impacts. They are also used to provide routing information for microsimulation or deterministic models.

The use of tactical models is advantageous where there is likely to be traffic rerouting as a result of the scheme. Since the models already exist, they can be used for quick tests on road closures or potential rat runs and also to investigate the impact of multiple schemes which are not yet on street. Conversely, building them in the first place is extremely labour intensive and they have relatively long run times of as much as 48 hours. They use aggregate flows rather than modelling individual vehicle behaviour and they use average signal timings, so they cannot be used to examine the detailed operation of a scheme.

For schemes with considerable or wide-reaching network impacts, a tactical model can be used in conjunction with deterministic and

microsimulation modelling. It is normal for successive iterations to be required with these models in order to assess the impact of a scheme on traffic volumes and driver route choice (section [A3.4.5](#)).

Aimsun Next³⁶, SATURN³⁷ and Visum³⁸ are the three packages which can be used by TfL for tactical modelling in London.

5.3.1 Aimsun Next

Aimsun Next is transport modelling software produced by Aimsun, a subsidiary of Siemens Mobility. It is a fully integrated application which includes microsimulation, mesoscopic simulation, macroscopic and travel demand modelling. It also has the capability to combine these in two hybrid simulators: micro-meso and macro-meso. These Guidelines only consider the microsimulation aspect of Aimsun Next as, at the time of publishing, TfL is still investigating the additional capabilities.

5.3.2 SATURN

SATURN is a suite of programs developed by the Institute for Transport Studies at the University of Leeds in partnership with the transport consultant Atkins (SNC Lavalin). It is a combination of network analysis programs that combine traffic simulation and traffic assignment to analyse the impact of traffic management on a regional, sub-regional and local scale. The main use of SATURN at TfL is at a strategic level, as the LoHAM traffic assignment model (section [A3.4.4](#)) is built in SATURN. For further information, contact StrategicModelling@tfl.gov.uk. For this reason, use of SATURN is not covered in detail in these Guidelines.

5.3.3 Visum

Visum is developed by PTV as a system for travel demand modelling, transport planning and network data management. It is designed for multi-modal analysis which integrates different modes of transportation into a single network model. It is used to conduct operational assessments to indicate the impact of short-term changes on the network and is usually commissioned to support major development schemes. Modelling traffic reassignment and congestion impacts due to local network changes requires detailed transport network representation and assignment methods capable of replicating congestion effects.

³⁶ <https://www.aimsun.com/aimsun-next/>

³⁷ <http://www.saturnsoftware.co.uk>

³⁸ <https://www.ptvgroup.com/en/solutions/products/ptv-visum/>

NM's tactical model, the Operational Network Evaluator (ONE) Model, is developed in Visum. It covers Greater London, out to and including the M25. The model covers a large area so not all roads are represented. Motorways, A Roads, the TLRN, the SRN, and most other roads carrying in excess of 100 vehicles an hour are included. The ONE Model is used to assess schemes and investigate the implications of local network changes, such as improvements to junction layout or signal timings, on the wider network. Outputs from the ONE Model include flow difference plots, link speeds and junctions approaching saturation. At the time of publishing, the ONE Model represents AM and PM peak periods.

6 Summary



This section has attempted to provide assistance to the scheme Promoter and has evolved from the previous version to provide additional considerations for a range of influencing factors to enhance this support. The aim of this part of the document is to guide the reader towards making decisions from the outset with regards to scheme modelling assessment on London's road network that influence the best outcomes for all road users. The intention is to promote best practice and transparency across the industry. We hope that you find these Guidelines useful and informative in order to elevate standards, promote knowledge sharing and further collaborative efforts.

We are very appreciative of the support from all internal and external contributors to the creation of these Guidelines. We look to take on board feedback from all stakeholders and are always open to recommendations. Please direct any feedback to TfLModellingGuidelines@tfl.gov.uk.



PART B – MODELLING
GUIDANCE

I Introduction to Part B



Within the TfL Network Management Directorate (NM), Network Performance Delivery (NPD) is dependent on comprehensive modelling and supporting information from clients (including London boroughs and TfL departments) and consultants in order to effectively design, assess, implement and operate traffic schemes.

Appropriate, comprehensive and accurate modelling is necessary to ensure traffic schemes are:

- Assessed for impacts and benefits;
- Effectively designed to satisfy any objectives;
- Clarified to avoid confusion or misinterpretation of the design;
- Communicated to the public and other stakeholders in terms of the design and impacts; and
- Effectively and efficiently implemented and operated.

Part B of the Traffic Modelling Guidelines contains technical advice relating to modelling best practice. The first chapter initially covers general topics that are common to all types of traffic model undertaken by or for TfL Network Performance (NP), with subsequent chapters containing more detailed advice for specific traffic modelling software methods. It is recommended that all model developers producing a traffic model within the London area familiarise themselves with Chapter **B2** on **Modelling Principles**, prior to commencing model development, and irrespective of the particular software they intend to use.

Within **Part B** of the Traffic Modelling Guidelines, an assumption has been made that the reader has an awareness of basic traffic engineering principles, covering traffic signal control, traffic flows and traffic surveys. Specific concepts and signal terminology that should be already understood include phases, phase minimums, intergreens, phase delays, stages, stage minimums, interstages, cycle times, offsets, saturation flow and degree of saturation (DoS)³⁹.

This level of awareness would typically come from introductory courses to traffic signals and industry-standard software packages, combined with experience in the traffic engineering / transport planning field.

The remainder of **Part B** is organised into chapters appropriate to different types of traffic model and modelling software. Individual chapters can be referred to for relevant guidance on the traffic model type and modelling software being used for a particular project. If any specialist competencies relate to specific modelling software, these will be stated in the chapter for that package.

39 DfT Traffic Signs Manual Chapter 6 Section 6 describing these terms
https://assets.publishing.service.gov.uk/government/uploads/system/uploads/attachment_data/file/851465/dft-traffic-signs-manual-Chapter-6.pdf

2 Modelling Principles



This chapter contains key information which should be read and understood by anyone undertaking traffic modelling. The key areas that will be covered include:

- Levels of Modelling;
- Three Stage Modelling Process;
- Model Auditing Process;
- Planning a modelling project;
- Data Collection;
- Base and Proposed Model Development;
- Proposed Model Optimisation; and
- Model Reporting.

All model developers are also encouraged to familiarise themselves with **Part A** of the Traffic Modelling Guidelines to ensure that the considerations outlined there will be met by any Proposed model.

2.1 Modelling Overview

This section provides an overview of the different levels of modelling covered by these Guidelines, modelling undertaken early in the design process, the Three Stage Modelling Process and the Model Auditing Process.

2.1.1 Levels of Modelling

Different levels of models may be required for a modelling project depending on the purpose of the scheme and the outputs that are required. It is common for multiple modelling levels to be required to fully assess the impacts of a proposal. The main levels of modelling used by NM for scheme assessments are summarised in the following subsections. The decisions on the level(s) of modelling required as part of a scheme assessment should be agreed during the relevant model scoping meeting, which is discussed further in **B2.1.5.1**.

2.1.1.1 Deterministic Modelling

Deterministic traffic models are used to assess junction performance and calculate optimised signal timings, including the coordination of signal timings between junctions. They are based on the capacity of individual stoplines based on geometric inputs and fixed traffic flows. Deterministic models are based on aggregate traffic flows and average signal timings, therefore complex signal strategies, demand dependency and blocking back of queues cannot be explicitly modelled.

The main outputs from these models include degree of saturation (DoS) and mean maximum queue (MMQ) lengths. The models can also provide a general indication of whether a proposal will operate comfortably within the capacity of a road network.

For further information on deterministic modelling, refer to Chapters **B4** and **B6** covering **LinSig Modelling** and **TRANSYT Modelling** respectively.

A second category of deterministic models are used to assess the performance of unsignalised or priority-controlled junctions and roundabouts. Priority control occurs when traffic on a side road or minor road gives way to traffic on a major movement or circulating carriageway. The key inputs for this type of modelling include geometric and visibility details for the junction. Outputs for this type of modelling include delays, queues and capacity. Schemes which include unsignalised junctions and roundabouts can be modelled with PICADY and ARCADY, which are

included within the Junctions software package and as optional modules within TRANSYT 16 (covered in [B6.4.6.5](#)).

2.1.1.2 Microsimulation Modelling

Microsimulation models can represent individual vehicles, cyclists and pedestrians within a modelled network using behaviour models. Therefore, microsimulation can be used to assess congested networks more accurately than other modelling levels as they can explicitly represent queuing behaviour, blocking back through junctions, merging and random events such as breakdowns or lane closures.

Complex signal control features, such as demand dependency and bus priority, can be replicated in microsimulation models using detectors and vehicles / pedestrians in the model. Depending on the software, microsimulation models can also replicate the behaviour of on-street signal operation, where modelled vehicles and pedestrians can alter the modelled signal timings. However, microsimulation models are unable to optimise signal timings and are therefore often used together with deterministic models.

Microsimulation models allow for the effects of randomness, where different random seeds are used to give a variety of results with differing traffic and pedestrian arrival profiles. By averaging the outputs from many random seeds, the natural variability of real-life traffic conditions can be captured in the results.

The most common outputs of microsimulation modelling are journey times, which are recorded over predetermined distances over which a reasonable number of vehicles or pedestrians travel. This journey time information can be broken down by mode, so that the impact of a scheme on individual user classes can be assessed. Numerous other outputs, such as flows, queue lengths, delays and speeds, can be exported from models in either data or heatmap formats. Microsimulation model outputs can also be used by other software, such as for production of 3D visualisations or calculating emissions outputs from modelled vehicles.

For further information on microsimulation modelling, refer to Chapters [B3](#) and [B7](#) on [Aimsun Next Modelling](#) and [Vissim Modelling](#).

2.1.1.3 Tactical Modelling

Tactical modelling can be used to understand how changes to the road network will affect route choice, vehicle speeds and congestion. Tactical models are used in modelling assessments where vehicle rerouting is a likely result from the scheme proposals. They use aggregate flows rather than modelling individual vehicle behaviour, and use average signal timings, so they cannot be used to examine the detailed operation of a scheme.

Tactical models are used to predict how vehicles will use the future road network, typically within a 5-year time horizon. They can also assess the cumulative impact of traffic reassignment resulting from multiple proposals. This is discussed in more detail within [B2.1.4](#), where the Three Stage Modelling Process is outlined. The main outputs produced by tactical models are flow difference plots, network statistics and queue plots.

Mode choice behaviour is not explicitly modelled in tactical models, however, the effect of mode choice can be reflected at a tactical level using outputs from strategic travel demand models.

For further information on tactical modelling refer to Chapter [B5](#) on [Highway Traffic Assignment](#).

2.1.1.4 Pedestrian Modelling

Specific pedestrian modelling is carried out for schemes with a pedestrian focus, and microsimulation modelling is most commonly used. Pedestrian microsimulation modelling represents individual pedestrians and how they interact with each other and other items or obstacles in their environment. In similarity with traffic microsimulation modelling, different pedestrian types can be modelled to represent different walking speeds or other factors such as pavement space used.

Outputs from pedestrian modelling include pedestrian levels of service, heat maps, journey times and videos. Data from pedestrian modelling can also be used in 3D visualisations.

For further information on pedestrian modelling refer to Chapter [C3](#) on [Pedestrian Modelling](#).

2.1.1.5 Emissions Modelling

Estimates of road traffic emissions can be based on the type of vehicle and its average speed on a section of road. This is a widely used approach, which uses outputs extracted from deterministic or tactical modelling. However, as these models are based on aggregate information, this approach is unable to assess the emissions produced by a vehicle as a result of acceleration. Where there is significant stop-start behaviour, such as in an urban environment, detailed emissions modelling therefore uses microsimulation modelling outputs to provide a more accurate estimate. The detailed outputs for each vehicle in a microsimulation model can be exported for use in various emissions software packages.

Guidance on using instantaneous emissions modelling with individual vehicle data can be found in Chapter [C4](#) on [Emissions Modelling](#).

2.1.2 Common Model Simplifications

Simplifications are inherent in models, as discussed in [A3.1](#), and may vary between different levels of modelling. They are necessary to achieve a balance between model quality, model complexity and timely delivery. Some of the common model simplifications that are made include:

- **Response to changing traffic conditions** – Deterministic and microsimulation models typically do not account for alterations to traffic routing, time of travel, or react to changing congestion within the modelled environment during the simulation. Tactical models which can handle dynamic route choice have the capability to alter trip route choice within the modelled period, however the added complexity of this capability must be carefully justified. Typically tactical models output a single set of trips and routes per assignment;
- **Variations in traffic demand** – Models are built to represent a single, or set of, 'neutral' days across the year. This is usually a midweek day during term time, on a day in which light conditions or adverse weather do not affect the demand or flow of vehicles;
- **Simplification of traffic flows** – Vehicle / pedestrian types and their behaviours are simplified in all models. Models either standardise vehicles into Passenger Car Units (section [B2.3.4.1.1](#)), or group them into sets of users with similar characteristics. These could be performance characteristics, physical space requirements, filtering behaviours, accessibility limitations or many others;

- **Trip origins and destinations** – Models do not represent individual trip start and end points, they are either aggregated into demand zones or loaded onto the edges of a model and then exit the model elsewhere at another edge. The number and distribution of trips between origins and destinations are typically fixed in models. The potential modal shift, demand suppression or peak spreading incurred by a scheme is not usually modelled;
- **Modelled networks** – Traffic models used in London are typically either Lane or Link-Based and may limit the representation of weaving or filtering through traffic. Pedestrian models do not capture all informal crossings which occur in reality;
- **Treatment of congestion** – Unless scheme assessment is undertaken in a microsimulation model, the effects of congestion blocking junctions and interfering with the flow of traffic elsewhere on the network may not be adequately represented. Manual adjustments are often required to reflect congested conditions in other levels of modelling;
- **Operation of traffic signals** – Many models cannot capture the detailed effects of adaptive or optimisable traffic signal operation, such as SCOOT, bus priority or automated strategy application. As a consequence, these models typically simulate a fixed cycle time and green times. Microsimulation models built with an interface to the UTC system (such as UTC-Vissim, discussed in [B7.4.5.3](#)) can accurately represent more intelligent signalling strategies; and
- **Modelling complex route choice** – Models simulate trips that have a single fixed origin and destination. Where tactical models are used, route choice is calculated based on vehicles finding the least cost path through the network to reach their destination. Other modelling software typically does not have the ability to predict or affect route choice. Modelling certain vehicle behaviours, such as taxis looking for a fare or delivery vehicles making multiple drop offs, often cannot be adequately represented in models. Where models include multiple vehicle classes, routing behaviours can however be applied to represent differences in the way each class uses the available network. This could account for behaviours such as use of bus lanes, compliance width / height / turn restrictions or differing levels of network knowledge.

2.1.3 Early Design Stages

Prior to detailed scheme assessment with the Three Stage Modelling Process (B2.1.4), and formal submission to TfL under the Model Auditing Process (B2.1.5), earlier stages of scheme design take place. This section provides an insight to these early stages of the design lifecycle and the involvement of modelling assessments in the project delivery approach.

Once the business outcome of a project is decided and the benefits of undertaking the project are established, key stakeholders are introduced to the project to discuss any anticipated difficulties in designing and delivering the scheme.

The feasibility stage is where a variety of options are considered and designed in order to achieve the proposed outcomes of the project. Modelling undertaken at this stage will narrow down the proposed options so that a single feasible option can be progressed to a full scheme assessment. This modelling is typically carried out using deterministic modelling software, as these models are the simplest to build. The optioneering process gives the key project stakeholders a good understanding of each option's impact on the network. The feasibility model results allow the designs to be continually improved, usually involving collaboration between designers, modellers and other key parties.

Optioneering will also aid in fixing the scope of the project, and once a decision is taken on the preferred option(s), work can move forward to a full Three Stage Modelling assessment and formal submission under the Model Auditing Process. Although the focus of the Traffic Modelling Guidelines is on detailed scheme assessments, the same modelling concepts can be applied to all kinds of assessment including optioneering.

2.1.4 Three Stage Modelling Process

Over recent years the Mayor's Transport Strategy⁴⁰ has reduced focus on improving car trips and shifted towards developing a more sustainable transport network, providing benefits for buses, cyclists and pedestrians. The move towards sustainable travel, together with changes in infrastructure and public spaces as a result of population growth, has resulted in many transport schemes being implemented within the same time frame. Therefore, the Three Stage Modelling Process was developed in order to capture the interaction between model types and to better understand impacts such as traffic reassignment due to neighbouring schemes. The process ensures that both the isolated impacts of a scheme and the overall future state of the network are considered, enabling a more holistic analysis of the network, focusing on the impact on every journey. The three stages of this process are detailed in the following sections and in **Figure 9**.

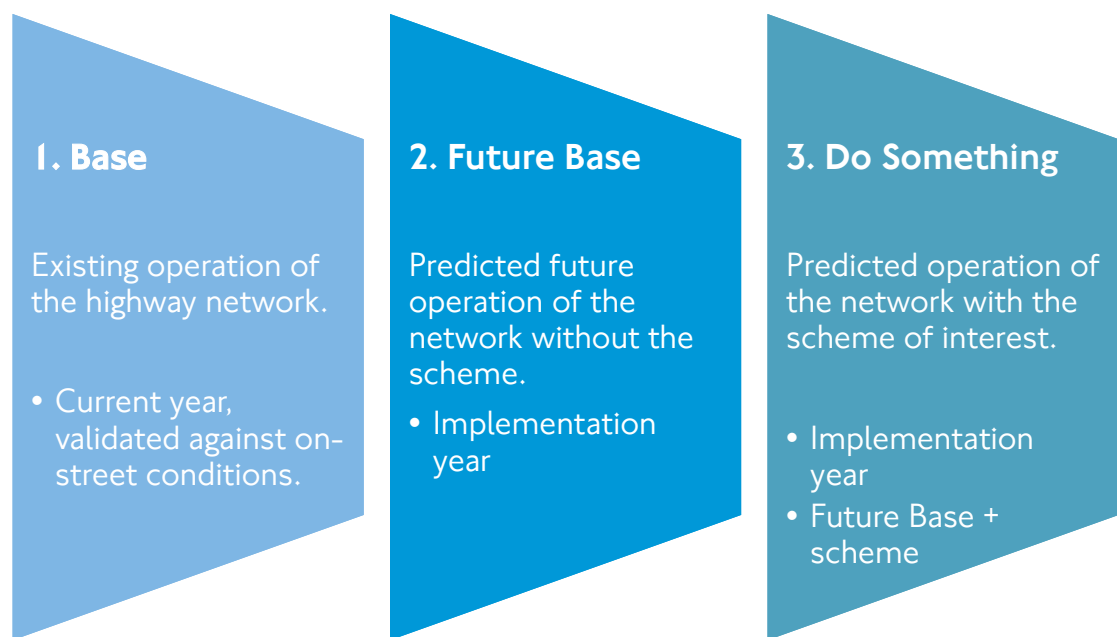

Figure 9: The TfL Three Stage Modelling Process

2.1.4.1 Stage 1: Base Model

A Base model is a model that has been demonstrated to accurately represent traffic conditions as observed and measured on street. It should be suitable for use in analysing current network performance and as a benchmark against which other modelling scenarios can be tested.

The initial tactical Base model is first reviewed in terms of signal timings, network coding, junction capacities and turning count validation for the study area to create a scheme-specific tactical Base model. Base deterministic and microsimulation models are also developed to represent the existing operation of the network and are validated against on-street conditions to the standards defined in the Model Auditing Process, as detailed in [B2.1.5](#).

2.1.4.2 Stage 2: Future Base Model

The Future Base model represents the future year in which the scheme under consideration is planned to be implemented, but it does not include the scheme itself. The model should include all future network changes planned for implementation up to the future year being assessed. This includes schemes which may not be finalised and uses the most recent proposals at the time of Future Base model development, which may be subject to change at a later date.

Through an iterative process the tactical and deterministic models are used to refine optimised signal timings for the expected future year flows. Once optimisation has been carried out, routes and signal timings can be fed into the microsimulation Future Base model.

2.1.4.3 Stage 3: Do Something

The Do Something model represents the future year in which the scheme under consideration is planned to be implemented, and also includes the scheme itself. The scheme proposals are coded into the Future Base model to create the Do Something model.

As with Future Base modelling, the refinement of the signal timings takes place during an iterative process between deterministic and tactical models, and the final optimised signal timings and routes are fed into the microsimulation Do Something model.

The isolated impact of the scheme in question can be determined by comparing the Do Something and Future Base scenarios. In some instances, it can additionally be useful to determine the predicted change from the

current situation, and so a comparison between the Do Something and Base results can also be made.

2.1.4.4 When to use the Three Stage Modelling Process

It is recommended that the Three Stage Modelling Process should be used in operational scheme assessments when:

- Traffic reassignment is anticipated as a result of the scheme;
- Traffic reassignment is anticipated as a result of adjacent scheme(s);
or
- Network changes occur within the model boundary as a result of adjacent schemes.

This will cover the majority of significant schemes in London, so it will only rarely be the case that the Three Stage Modelling Process does not apply. The decision as to whether a scheme is to be subject to the Three Stage Modelling Process would occur during the Base scoping meeting, discussed in **B2.1.5.1**.

2.1.4.5 Scheme Assessments

The diagram in **Figure 10** below shows the iterative process used in order to produce the Base, Future Base and Do Something models for a scheme assessment following the Three Stage Modelling Process.

Firstly, the tactical model needs to be reviewed and validated to a Base year, with the assistance of signal timings and capacities from validated Base deterministic models. The routes from the tactical model are then used during calibration of the microsimulation Base model.

An extra stage is applied for building future year models, as an iterative process needs to be undertaken between the tactical model and deterministic models in order to optimise the signal timings with the predicted future year flows. The iterative process involves transferring the tactical model flows into the deterministic model, optimising the signal timings, and applying the new signal timings in the tactical models. Once the flows are settled, the routings are fed into the microsimulation model to start the build of the future year models.

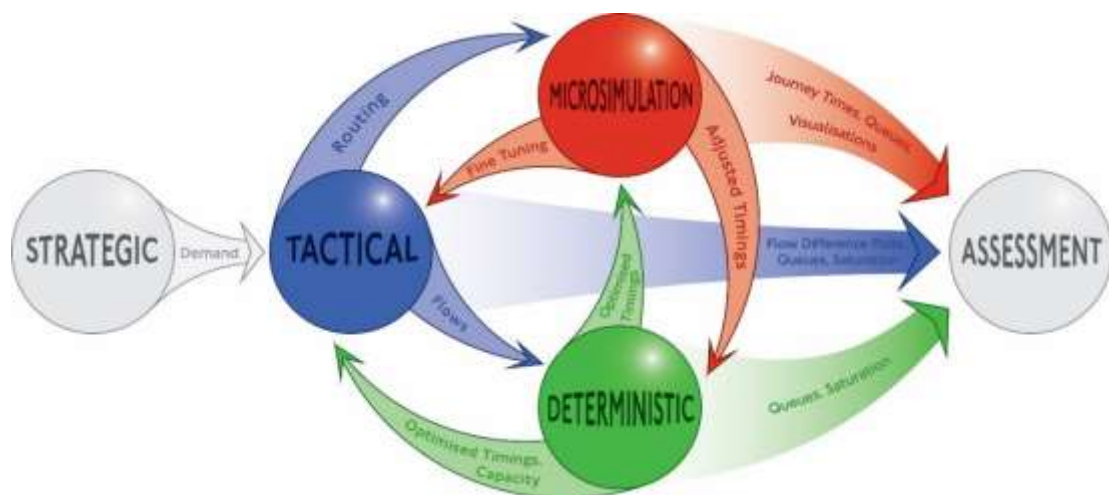

Figure 10: Interactions between different levels of modelling within the Three Stage Modelling Process

2.1.5 Model Auditing Process

Traffic model development is a complex task that can be completed in a variety of ways, and the process of auditing a model can therefore be challenging. The Model Auditing Process (MAP) has been created by the Network Performance (NP) Modelling & Visualisation team (M&V) to simplify this process by providing a structured framework which leads all interested parties through model development, submission and auditing. MAP was implemented in April 2008 and the most recent version at the time of publishing, MAP v3.5, was released in March 2017. The latest MAP documentation is available, without charge, from the TfL website⁴¹.

MAP contains six stages, which outline traffic model development and auditing from initial scoping of the Base model through to submission of the Scheme Impact Report (SIR) to the NP Network Impact Specialist Team (NIST). It defines each model auditing step, assigns key roles, encourages communication and provides standardised auditing check sheets.

The primary objective of MAP is to ensure that traffic models submitted to NPD are developed, calibrated and validated to an appropriate standard. This ensures that NPD is able to provide advice to NIST based on accurate and robust modelling. Further information on NIST can be found in [A2.1.2](#).

MAP applies in all circumstances where NIST requires traffic modelling to assess impacts on the Transport for London Road Network (TLRN) or the Strategic Road Network (SRN). However, where a borough is the Promoter of a scheme that does not impact on the TLRN or the SRN the use of MAP

41 <https://www.tfl.gov.uk/trafficmodelling>

is only advisory. All traffic models commissioned by TfL and submitted to NPD are audited in accordance with MAP.

MAP is designed to give a common structure for all model submissions. However, for each modelling package the details, and consequently the checks, are different. At the time of publishing there are four software-specific MAPs, for Aimsun Next (AMAP), LinSig (LMAP), TRANSYT (TMAP) and Vissim (VMAP). However, a similarly structured six-stage approach can be beneficial when applied to any type of modelling software.

The six stages established by MAP are:

- **Stage 1** – Base Scoping Meeting;
- **Stage 2** – Calibrated Base Model Submission;
- **Stage 3** – Validated Base Model Submission;
- **Stage 4** – Proposal Scoping Meeting;
- **Stage 5** – Proposed Model Submission; and
- **Stage 6** – Submission of SIR to Promoter.

Each stage has unique requirements, as outlined in the MAP documents, however the administrative process for dealing with model submissions and the communication associated with each stage remains the same.

MAP also defines six key roles:

- **Promoter (P)** – The person responsible for delivering and project managing the proposal. Considered the client for a scheme;
- **Design Engineer (DE)** – The engineer responsible for creating the modelling for the Promoter. Normally a consultant traffic engineer engaged by the scheme Promoter;
- **Checking Engineer (CE)** – The engineer responsible for checking and signing off the Design Engineer's work as 'fit for purpose' for the Promoter. This is typically a senior consultant traffic engineer engaged by the scheme Promoter;
- **Signals Auditing Engineer (SAE)** – The TfL engineer responsible for checking and safety approving the signal infrastructure elements of the proposal;
- **Model Auditing Engineer (MAE)** – The TfL engineer responsible for auditing the modelling and assessing the network impact of the scheme; and
- **Network Assurance Engineer (NAE)** – The TfL engineer responsible for assessment, then approval / rejection of the Promoter's proposal (under the Traffic Management Act).

For all MAP Stages there are check sheets to be signed off by the DE, the CE and the MAE.

The following key points should be noted:

- All model submissions should be version controlled;
- All model submissions should be internally audited by the CE prior to submission; and
- All model submissions to NP should be sent to the NMSchemeAssessments@tfl.gov.uk email address.

2.1.5.1 Scoping Meetings

On initiation of detailed modelling work a Base scoping meeting should be arranged with all parties involved in MAP, as described in [A4.4](#). The scheme will be discussed at this meeting, along with the required outputs and modelling work that will be required at the Base and Proposed modelling stages. This constitutes the first stage of the MAP process, MAP Stage I, and provides an opportunity for the details of the modelling work and future submissions to be recorded within the Modelling Expectations Document (MED), which is discussed further in [B2.1.5.2](#) and used as a reference as the modelling work progresses.

A Proposal Scoping Meeting should take place at MAP Stage 4 once the Base modelling is approved, as described in [A4.5](#). This meeting should involve all the previously mentioned MAP parties. The aim of the meeting is to discuss the scheme proposals and modelling requirements in order to ensure a high quality and consistent approach to model development. Any changes and developments should be recorded and the MED updated.

2.1.5.2 Modelling Expectations Document

To ensure that there is no ambiguity relating to the modelling requirements for a scheme, a Modelling Expectations Document (MED) is produced following the Base scoping meeting at MAP Stage I. The MED summarises the agreed scheme-specific modelling requirements and is agreed by all parties before a scheme can progress to MAP Stage 2.

The content and size of the MED will vary in accordance to the scale and purpose of a scheme. Common topics that are included within the MED are:

- **Scheme Summary** – this should include a summary of the scheme, details of the Promoter, the scheme objectives and a summary of the proposed changes;
- **Model Area** – detailing the area to be covered by each level of modelling required by the project;

- **Peak Periods** – outlining the peak periods to be modelled for each modelling level, noting there may be differences between the different levels;
- **Software Requirements** – detailing the specific versions of each software to be used in the scheme assessment;
- **Calibration / Validation Criteria** – detailing any processes to be followed to ensure accurate representation of the Base situation within the models, and the targets to be met to achieve a calibrated / validated model;
- **Data Collection** – detailing the data required to build a Base model, including information on what data already exists and whether surveys need to be commissioned or site visits arranged;
- **Signal Data** – this will specify any signal timings that can be collected by TfL or the methodology for collecting signal timings on site at locally controlled junctions or crossings;
- **Interaction Between Modelling Levels** – detailing which modelling levels are to be used and how the different levels will interact;
- **Proposed Modelling** – this should detail if there are any specific requirements for building the Proposed models;
- **Documentation / Outputs** – defining which outputs are to be produced as part of the modelling process, including the scenarios to be compared. The supporting documentation that is to be produced alongside model submissions should also be specified;
- **Programme** – detailing any key milestones / deadlines for the modelling project; and
- **Contact Details** – listing the contact details of all involved parties.

Scheme proposals may evolve throughout the modelling process. The MED should be reviewed during the MAP Stage 4 Proposal Scoping Meeting and updated if any of the modelling requirements have changed.

Care should be taken to make sure that all elements of the modelling process are carefully thought through, discussed at the scoping meetings and then documented.

2.2 Planning a Modelling Project

Adequate time should be given to build fit-for-purpose models, including time allocated for thorough analysis. This can be achieved by planning the project, allowing enough time for each task and avoiding unnecessary delays early in the project.

The following sections detail the key aspects of a modelling project that should be considered when planning a scheme assessment and the associated programme.

A degree of flexibility needs to be incorporated into any modelling project, to encompass any required changes to the initial modelling requirements. Any changes to the modelling requirements should be agreed with the project stakeholders.

2.2.1 Network Familiarisation

Before commencing any modelling work or measurements on site, it is important to become familiar with the study area by identifying the following:

- Junctions and pedestrian crossings covered, which each have a unique TfL site number. All requests for site information should be directed to AssetOperationsDataLegalRequest@tfl.gov.uk;
- The TfL signal area the site numbers fall within, which is defined by the UTC group / region number (if applicable, obtained from TfL NPD);
- Time period(s) under consideration; and
- Date(s) when traffic flow data was collected, if available.

Section **B2.3** details some of the initial steps that should be taken in order to become familiar with the area to be modelled.

2.2.2 Modelling Purpose

The development of a clear brief can prevent ambiguity and increase the likelihood of producing fit for purpose traffic models. It is important to define the intended purpose and include any specific objectives and required modelling outputs. This will help when deciding on the scope of the model and when analysing modelling results. The model developer should be made fully aware of this purpose in order to ensure that the final modelling meets the required criteria.

The scheme objectives will determine which modelling outputs are required, with the model scope determining what outputs are possible. The scope of the traffic model as defined in MAP Stage I (**B2.1.5**) should be

clearly stated in accompanying reports and in any discussion or reference to results obtained from the model. The model developer should also relate decisions made in the model's development process to the requirements of the model, as defined by its purpose.

2.2.3 Spatial Scope

When developing Base models, all road users should be considered and more than one model may be required to capture the impact over a large area. The model boundary should encompass the area for which traffic flows, journey times or delays will be significantly affected by the scheme. This includes the impact of a scheme on the surrounding network, not just the individual junction(s) or area of works proposed.

It is important to consider the proposed scheme objectives and potential impacts when discussing the scope of the Base model to ensure that appropriate model outputs are produced. The model boundary should be agreed with TfL during MAP Stage I, as described in **B2.1.5**. For guidance, junctions should be included in the model boundary if the proposal:

- Significantly changes the traffic flow at the junction;
- Physically changes the road network;
- Changes the operation of the traffic control; or
- Is expected to cause exit-blocking at certain junctions, either as a result of the proposal or changes in the local traffic control strategy.

The model boundary should include the maximum extent of expected queuing on modelled entry links and should be scoped so there is sufficient capacity for all vehicles to load into the network for the modelled time period, for all scenarios. This is to ensure:

- Any upstream blocking back effects can be easily identified and mitigated; and
- That the model does not produce a biased result, by underestimating the capacity.

If the model area is part of a Cableless Linking Facility (CLF) or UTC group with a proposed change in cycle time, then the whole operational group must be included in any modelling. If there is no proposed change to cycle time, then the whole group does not have to be included provided none of the above criteria are met by junctions adjacent to the proposal.

It is recommended that Base scoping meetings (**B2.1.5.1**) occur prior to the scheme being registered on the NM workbook (**A3.6.1**). This will

ensure that all NM NPD requirements are captured by the Promoter and Design Engineer prior to development of the scheme design.

2.2.4 Required Outputs

When planning a modelling project, it is important to determine what modelling outputs are required to achieve the purpose of the modelling project. The modelling outputs must clearly demonstrate how the outcomes and benefits of a scheme are achieved and illustrate the impacts. For example, if the purpose of a scheme is to improve bus journey times then outputs would be required that separate bus journey times from those of other modes. Once this has been determined it will be possible to determine the level or levels of modelling required and the specific modelling software to be used.

For further information on the different levels of models and their outputs, refer to **Table 2** in **A5 (Which Traffic Modelling Software? Why?)**.

2.2.5 Modelling Software

Once the required outputs of a scheme are known the type of modelling software to be used in an assessment can be determined. The software typically used for operational modelling assessment has been listed below:

- **Deterministic** – Used to calculate the optimal signal timings based on network conditions. The deterministic model's signal timing output will feed into all other models produced. Software packages used include LinSig (Chapter **B4**) and TRANSYT (Chapter **B6**);
- **Microsimulation** – Microsimulation modelling, where models typically cover larger areas compared to deterministic modelling. Microsimulation models capture a high level of detail that is lacking in tactical modelling. Within the Three Stage Modelling Process (section **B2.1.4**), it is used to assess detailed impacts of the scheme. Software packages used include Aimsun Next (Chapter **B3**), LEGION (section **C3.3.2.1**) and Vissim (Chapter **B7**);
- **Tactical** – Tactical modelling (Chapter **B5**) is the level of macroscopic model used within TfL for operational purposes. Tactical models cover large areas and are primarily used in the Three Stage Modelling Process (**B2.1.4**), to understand route choice and the impact the scheme has on the wider network. Software packages used include Aimsun Next (Chapter **B3**) and Visum; and

- **Mesosopic** – A compromise between tactical and microsimulation, where there is less detail than microsimulation modelling and more detail than tactical modelling. The development of NM’s mesoscopic capability is ongoing at the time of publishing and so the main body of this chapter focuses on deterministic, tactical and microsimulation modelling. However, its usage should be discussed at Stage I of the Model Auditing Process (MAP) in section **B2.1.5**. Software packages include Aimsun Next (Chapter **B3**), Vissim (Chapter **B7**) and Visum.

For further guidance on the different levels of modelling, refer to sections **A3.4** and **B2.1.1**.

2.2.5.1 Versions of Modelling Software

Software companies frequently release new versions of their software, either to introduce new features or to address specific software issues. Consideration should be given to the software available and which version is the most appropriate to use for the model(s) being developed. Although it may seem probable, it is not always the case that the most recently released version of the software is the most appropriate one to use, even for development of entirely new models.

It is the collective responsibility of all MAP parties to determine and agree the most appropriate software versions to be used before any modelling work commences.

Under no circumstances should software versions change between the calibration of a Base model and the production of a Future Base and Do Something model (section **B2.1.4**). Even with identical inputs, it is common for different software versions to produce different results. It will therefore likely invalidate a previously validated model if it is used in a software version different from the one in which it was developed.

2.2.6 Planning Traffic Surveys and Data Collection

Traffic surveys and data collection should be considered at an early stage of planning a modelling project. Surveys and data collection need to be planned in advance to ensure they are representative of typical traffic conditions and so that enumerators, where required, can be commissioned to undertake the work. The degree of data collection necessary depends on the modelling purpose and outputs required. Further information on the types of data that need to be collected as part of a modelling project is provided in section **B2.3**.

2.3 Data Collection

Once familiar with the modelled network it is necessary to collect the relevant information required to generate a fit-for-purpose traffic model. Without accurate data a model cannot be correctly developed, calibrated or validated. Data collection in this context refers to both making use of existing data sources and arranging for new data to be collected on site. Both of these areas are detailed in the following sections.

A common cause of inaccurate data is a lack of understanding and experience on behalf of those conducting a survey. On-site measurements should be conducted by an experienced practitioner who possesses a thorough understanding of modelling concepts and accepted survey methods, as well as experience of developing traffic models.

Where third parties have been contracted to undertake on-site observations, it is necessary to ensure the competence of the enumerator and that they have been accurately instructed on how to collect the required observations.

2.3.1 Existing Data Sources

When building Base models it is recommended to make use of available data where suitable, including the large amount of data that is routinely collected and maintained by TfL.

For signalised facilities, the following TfL paperwork should be consulted for all sites within the model boundary, and is available on request from AssetOperationsDataLegalRequest@tfl.gov.uk:

- Current TfL Controller Specifications and Timing Sheets, which detail phasing, methods of control, intergreens, phase minimums and phase delays along with other pertinent information relating to the site. Basic controller terminology is covered in more detail in [B2.3.8.1](#);
- Site Layout Drawings (SLDs), detailing junction layout, lane markings and site equipment; and where appropriate; and
- SCOOT Link Diagrams, showing link and node structure for SCOOT regions. See section [B2.3.8.2](#) for further detail on SCOOT terminology.

Other information collected by TfL that can be useful in Base model development includes:

- **Traffic survey data** – including counts performed by the TfL Traffic Surveys Team and other stakeholders, such as Manual Classified Counts (MCC). Available from ModellingData@tfl.gov.uk;
- **Automated Traffic Counters (ATC) and Automated Cycle Counters (ACC) data** – This data provides traffic volume and speed data broken down by categories, collected over several days. Available from ModellingData@tfl.gov.uk;
- **TfL's Cordon and Screenline data** – part of an ongoing programme of surveys on the central, inner and boundary cordons and the Thames, northern, peripheral and radial screenlines. Available from ModellingData@tfl.gov.uk;
- **iBus data** – providing information on bus journey times, frequencies and bus stop dwell times, as detailed in [B2.3.5](#). Available via a project's TfL sponsor; and
- **Cynemon** – a strategic cycling model built by TfL City Planning on the Cube platform, which estimates cyclist routes, flows and journey times at a strategic level across London. Data available from Cynemon@tfl.gov.uk, with further information in Chapter [C2](#) on [Cyclist Modelling](#).

Detailed drawings, maps and aerial photographs can be used to help inform site layout, however a site visit must be carried out to confirm the accuracy of any material used.

The internet provides a valuable resource for mapping and aerial photography, which can be useful for reference during initial stages of network familiarisation. Websites and associated tools commonly used for this purpose include:

- Google Maps⁴²;
- Google Streetview⁴²;
- Google Earth⁴³;
- Bing Maps⁴⁴;
- Bing Streetside⁴⁴;
- OpenStreetMap⁴⁵; and
- TomTom⁴⁶.

42 <http://maps.google.co.uk>

43 https://www.google.co.uk/intl/en_uk/earth/

44 <http://www.bing.com/maps/>

45 <https://www.openstreetmap.org>

46 https://www.tomtom.com/en_gb/traffic-index/london-traffic/

Of the aerial photography options available, Google Maps currently provides the highest resolution imagery of central London. In cases where aerial photographs are either obstructed or unclear, the '3D' option provided by Google Maps and 'Bird's Eye' view provided by Bing Maps show oblique images that provide an alternative view. Historical aerial photography can also be accessed via Google Earth.

One of the most useful online tools comes in the form of street-level panorama photography, showing a driver's eye view of the road network using imagery taken with 360° cameras. Examples include Google Streetview and Bing Streetside, with Streetview also providing historical imagery. Whichever tool is used it is important to make note of the year the imagery was taken to ensure it is suitable for the intended purpose.

A number of online tools can indicate typical traffic conditions for a certain day or time, including Google Maps' traffic conditions function. The TomTom My Drive site provides similar functionality but displays live traffic conditions only.

During model development vast amounts of data can be quickly checked using online data sources, from lane markings and parking restrictions to the specific details of road geometry or signage. However, online data sources should not be viewed as an alternative to site visits as material may be out of date and not representative of current on-street conditions. Instead, they offer useful supplemental information which can be confirmed later during site observations.

2.3.2 Site Visits

All models are developed using calibration data, which needs to be collected in the form of site observations and on-street parameter measurement. The quality of the final model, and any analysis derived from it, depends on the data used during model development. The consistent collection of data is paramount in ensuring the accuracy of any traffic model.

Data on its own does not provide enough information to develop an accurate model. The correct interpretation of the data requires a thorough understanding of on-site conditions. This understanding can only be acquired through visiting the site during each period for which a model is being developed. These site visits should include the collection of some of the more complex information which can only be undertaken by someone with appropriate knowledge and experience.

As described in **B2.3.1**, it is important to verify the accuracy of any drawings or aerial photography used during model development, to ensure their content accurately represents current site layout and appearance.

Site-specific parameters should also be recorded for all periods of the day for which the models are being prepared. Common examples of observations that can be noted or measured during site visits in order to replicate the network conditions are listed below:

- Junction / network layout;
- Link lengths, lane widths and pedestrian crossing distances;
- Lane / road markings and usage;
- Merging and lane changing areas;
- Cycle infrastructure, including cycle lanes (both segregated or mixed traffic conditions), cycle feeder lanes, Advanced Stop Lines (ASLs) and cyclist signals;
- Interaction of cyclists and general traffic / buses;
- Lane changing areas;
- Cruise times;
- Saturation flows at stoplines;
- Give-way behaviour;
- Visibility issues;
- Vehicle, cyclist or pedestrian spot counts;
- Right-turner storage and blocking effects;
- Flare lengths and usage;
- Vehicle usage of the flashing amber period at Pelican crossings;
- Fanning and funnelling;
- Exit-blocking;
- Bus lanes, hours of operation;
- Bus stop location and, type (layby / within traffic lane / floating) and bus stop dwell times;
- Car parks, street parking and interference during parking manoeuvres;
- Restrictions on the network (including parking, stopping and loading);
- Taxi ranks;
- Speed limits;
- Roadworks and other incidents, and their impact;
- Degree of saturation (DoS) and Underutilised Green Time (UGT) measurements, including noting the cause;
- Journey times (for both private and public transport); and
- Locations and lengths of queues.

Whilst many of these parameters can be measured in quantifiable terms, it is also important to record general site observations that capture more

subtle behaviour exhibited within the study area. It can be useful to note where traffic behaviour does not reflect street markings or the intended geometric design of a junction, for example where ahead-moving vehicles use a dedicated left-turn lane.

2.3.2.1 Sample Size

When measuring data, it is necessary to obtain a sufficient number of measurements to give confidence that average values collected are representative. For most data types it is recommended that a minimum of ten measurements are collected in order to obtain a suitable sample. Where the data being collected shows a large variation on street, a higher number of readings may be required in order to capture a representative average. Where a large variation in values is recorded, the sample size can be determined by achieving an accuracy level of $\pm 10\%$ (at 95% confidence level). In some cases fewer measurements may be appropriate, such as when recording link lengths and crossing distances.

Many parameters are time-dependent and should therefore be recorded for each period being modelled. For example, effective flare usage can vary at a site as a result of differing traffic patterns through the day. In order to achieve an overall measurement that is representative and to avoid difficulty during model validation, data sampling should be distributed across the whole of each period during which the measurement is being collected. It can be useful to check surveyed measurements compared to other available data sources to ensure they are representative of the peak hour. For example, when collecting on-street measurements it is useful to compare the proportion of results collected during cycles where demand-dependent stages were called compared to the demand dependency data supplied from the UTC system (see section [B2.3.8.5](#)). In the case of exit-blocking, it is important that the proportion of measurements collected whilst a junction is exit-blocked is representative of typical exit-blocking during the surveyed time period and that this is not the result of a network issue elsewhere in the network, as discussed in the next section.

2.3.3 Typical Traffic Conditions

Where data needs to be collected on site, it is necessary to ensure that network conditions are typical, that traffic signals are operating normally and that there are no unusual activities or travel patterns taking place.

Possible disruptions include, but are not limited to:

- **Day of week behaviour** – a neutral day should normally be chosen, typically a Tuesday, Wednesday or Thursday;
- **Planned events** – such as roadworks, demonstrations, ceremonial events, festivals, temporary road closures, public holidays and school holidays; or
- **Unplanned events** – such as traffic incidents, temporary loss of UTC control (local control), and temporary use of atypical (UTC or non-UTC contingency) timing plans or traffic management strategies.

Data should be collected for all critical time periods being studied, which may include a pre-peak warm-up period. The following time periods should usually be considered:

- AM peak;
- PM peak; and
- Inter-peak, late evening or weekend peaks, where there are significant levels of traffic.

The above list is not however exhaustive, and additional or multiple time periods may be required depending on site-specific traffic patterns, flow profiles or project-related interests. The start time and duration of each peak period will also vary. Variation in peak periods may occur between sites within the model boundary, therefore sufficient time periods should be surveyed to capture the overall peak period for all sites to be modelled.

NPD should be consulted when determining a programme for on-site data collection. It is necessary to check that normal traffic control conditions are expected during the planned survey times and this should also be confirmed once on site. Contingency dates should be set aside in case a scheduled survey has to be cancelled. NPD should also be informed in advance of any surveys so that they can monitor network conditions and capture average SCOOT timings if necessary (see [B2.3.8.3.1](#)).

2.3.4 Private Transport

Vehicle surveys are needed to capture specific data for calibration and validation purposes, to aid in Base model development. This section details some of the information that may be required for private transport.

2.3.4.1 Traffic Count Surveys

It is advisable that NPD is contacted before commencing road traffic counts to establish current best practice for data collection, and to ensure data formatting complies with TfL requirements. This is particularly important when surveys are not being carried out by those building the model, to ensure requirements are properly documented.

The time and duration of the peak periods to be modelled will typically be determined by the survey count data. The peak usually represents the period showing the largest volume of observed general traffic, although other factors may be taken into consideration, including cyclist volumes, queuing and where congestion charging zones are included. The modelled peak period is commonly assumed as one hour, however longer peaks should be used where appropriate, such as in the case of larger traffic models where the peak on street is at different times in different locations.

Traffic counts should be classified by vehicle type and aggregated in 15-minute intervals. Classified turning counts should be obtained at each junction or, in the case of a network with complex route choice, an OD survey may be more appropriate. The chosen approach will depend on the road network being modelled and type of software being used for the project. Traffic surveys can be performed on site by manual counters, using fixed location video cameras or via Automatic Number Plate Recognition (ANPR) systems.

Wherever possible, traffic counts should be recorded on the same day at all modelled junctions and for all modelled periods. In some cases, it may be acceptable to use flow-factoring techniques, based on flows recorded during another representative peak, but authorisation should be sought from the MAE before applying this technique.

Site visits should be carried out during traffic count surveys to collect pertinent calibration and validation data, and to ensure that site conditions remain typical. These visits are important as journey time, degree of saturation and queue length surveys should ideally be conducted while traffic counts are taking place. Multiple factors may have a bearing on survey results, such as traffic management, and it is important that these are identified in addition to the usual weather and incident reports provided by survey companies. It is advisable to contact NPD to check the UTC system logs to determine whether any faults or non-timetabled operation occurred at the time of the traffic surveys.

Classified turning count surveys have inherent limitations. Before they are used in a model, a check must be made to see whether traffic leaving one junction arrives at neighbouring junctions. If there is a discrepancy of more than five percent between junctions, short site surveys should be undertaken to determine if there are other major sinks and sources of traffic (such as side roads or car parks) that were not captured in the original survey. If sinks or sources are found, 15-minute spot counts should be conducted to estimate hourly flow rates. Where a discrepancy exists, and no sinks or sources are discovered, a 15-minute spot count can be conducted to compare with surveyed flows to see if the original counts are reasonable. To get an accurate spot count, it is recommended that the flow is recorded over a whole number of completed cycles.

Analysis of traffic flows across the whole network may highlight a particular count site as being in error, for example if flows at neighbouring survey sites are out by a similar value. Where a manual counting error appears to have been made, a general rule is to take the larger flow count from adjacent survey sites as being accurate, as it is more common for errors to result in under-counting than over-counting. This also represents the worst case as far as the network is concerned, as the largest observed flow will be modelled.

2.3.4.1.1 Passenger Car Unit

Traffic is composed of various types of vehicles, the range and relative composition of which can vary from location to location. Traffic modelling software packages frequently use a common unit, known as the Passenger Car Unit (PCU), to represent general traffic. Common vehicle types are assigned a conversion factor so that an equivalent PCU value can be generated from classified vehicle data. Typical PCU values used for different vehicle types are shown in **Table 3**.

Where cyclists are present, their volume can have an impact on the calibration and validation of traffic models. As the volume of cyclists changes, their impact on traffic behaviour varies in a non-linear manner. The considerations to be taken into account when modelling cyclists are discussed in Chapter **C2** on **Cyclist Modelling**.

Table 3: Passenger Car Unit (PCU) values for various vehicle types

Vehicle Type	PCU Value
Pedal Cycle	0.2 ⁴⁷
Motorcycle	0.4
Passenger Car	1.0
Light Goods Vehicle (LGV)	1.0
Medium Goods Vehicle (MGV)	1.5
Buses and Coaches	2.0
Heavy Goods Vehicle (HGV)	2.3

2.3.4.2 Cruise Times / Speeds

Cruise times reflect the typical non-delayed time taken for a vehicle in the middle of a platoon to travel from stopline to stopline, as would be the case if there were no traffic signals to cause a reduction in speed. Cruise times should be used as an input into traffic models whenever possible as they tend to be more accurate than cruise speeds, which could lead to incorrect offsets being calculated during signal timing optimisation. In some cases however, depending on the model type, purpose or project-specific considerations it may be appropriate to carry out a dedicated speed survey.

It may prove difficult to obtain accurate free-flow cruise times in congested conditions. If congestion prevents data collection it is therefore advisable to measure free-flow cruise times outside of peak hours. An alternative approach is to measure the cruise time for a free-flowing section on each approach, and extrapolate a value for the whole distance, based on the relative lengths of the free-flowing and congested sections. If persistent congestion always prevents cruise time measurement in a particular location, it may also be acceptable to measure cruise times for vehicles travelling in the opposite direction, but this should be noted in accompanying technical reports.

Full cruise time measurements may not be possible when the downstream stopline is not visible (this may be due to a bend or significant distance). In this case the measurement can be divided into segments using an arbitrary

⁴⁷ Research undertaken for TfL by TRL has indicated that a constant value of 0.2 PCU for cyclists may be an oversimplification, and could in fact vary based on cycle infrastructure¹⁴. See Chapter **C2** on **Cyclist Modelling** for further information. It is accepted that a value of 0.2 PCU should generally be assumed unless agreed otherwise with NP.

reference point, with segment journey times summed to obtain a total journey time for the full cruise time, or two surveyors can collaborate to choose a particular vehicle and communicate progress along the link between stoplines. A good sample is needed to develop confidence in the model results so it is recommended that a minimum of ten readings is taken on site to obtain a mean average, however more readings may be required if significant variation is observed. Refer to section **B2.3.2.1** for further information on sample sizes.

2.3.4.3 Journey Times

Journey times are usually measured between arbitrary reference points for the purpose of model validation, and may cover longer distances and multiple stoplines. All journey times should be collected under normal network conditions, free from incidents and events. Surveying should ideally take place at the same time as the traffic surveys, however, where this is not possible, the traffic conditions should be similar. It may be necessary to conduct journey time surveys over several days depending on the size of the network. If collecting journey time data over several days, similar neutral days should be chosen.

In recent years, GPS-tracked vehicle data has become more widely available for private transport journey time measurement, giving a much wider choice of survey dates, times and distances. In particular, it is possible to get an average journey time over multiple days, which provides a more robust value to validate microsimulation models against. ANPR is also now more accessible due to fixed cameras being routinely used for journey time monitoring along the TLRN, and temporary cameras can be installed by survey companies.

Where it is not possible to source GPS or ANPR data, the 'floating car' technique should be used. This involves one or more survey cars driving along prescribed routes within the modelled area and recording travel times between pre-defined points. These points are typically, though not exclusively, signalised stoplines or give-way road markings. The survey car(s) should attempt to balance the number of vehicles overtaking with those being overtaken, while remaining within the speed limit. Where stoplines are used as a datum, segment journey time measurements should begin and end immediately after crossing the stopline. These segmented journey times provide valuable information with respect to signal coordination and queue delay, which can become useful during later model development.

Multiple repeat journey time observations should be collected for each route, during each peak period. Since journey time observations vary

greatly in the real world, a sufficient number of observations should be made in order to show an accuracy of $\pm 10\%$ (at 95% confidence level). This accuracy level will determine the required sample size of observed journey times. There may be a practical limit of how many journeys a single vehicle can complete within a survey period, which should be taken into account when planning survey resources. Collecting multiple repeated journey time observations also allows an analysis of journey time variability (range, maximum, minimum and standard deviation). This information is useful to compare against model outputs during Base model validation. Refer to section **B2.3.2.1** for further information on sample sizes.

2.3.4.4 Queue Lengths

Queue length data can be useful for model calibration at locations where queues persist from one signal cycle to the next, and also to support models of priority junctions and roundabouts (discussed in section **B2.1.1.1**) where other validation data such as Ratio of Flow to Capacity (RFC) is difficult to measure. However, for priority junctions and roundabouts, there is greater variation in queue lengths and so ideally queue lengths should be surveyed and averaged over multiple days. Surveyed measurements at signalised sites are normally taken at a consistent point in the signal cycle (for example at the start of green), specified for each traffic lane and measured in metres or PCUs.

The level of accuracy in queue measurement surveys can often be lower than for other surveys as the definition of a queue can be subjective as well as difficult to identify.

In order to try and collect maximum queue length data on street, it is best to stand at the back of the queue at the start of green. Where vehicles will start discharging at the front of the queue and vehicles are joining the back of the discharging queue, the maximum length of the queue occurs at the point where an arriving vehicle is no longer delayed by the back of the discharging queue. If there are no arriving vehicles, then the maximum queue length remains the queue at the start of green.

It should be noted that queue lengths are not generally used for model validation, as explained further in **B2.4.2**.

2.3.5 Public Transport

The proposed scope of a traffic model will determine the level of detail required for public transport modelling and should be evaluated through discussion with the scheme Promoter (section A4.4). All fixed public transport stopping points and routes within the modelled area during the period of study should be noted, including any rail replacement services that may be in operation. Route maps available from TfL⁴⁸ can be used to verify routes and stop locations, although this data must be confirmed on street before it is used in any modelling.

Since 2009, all London buses have had iBus technology installed. iBus is the system that collects real time bus information as buses travel along their routes, which is used to provide real time bus arrival information at bus stops for passengers. The iBus system also records a variety of operational data that can be used for model calibration and validation, which will be discussed in the following sections.

iBus data can be requested from TfL, but any requests must go through a TfL sponsor to ensure the request is valid and formatted correctly.

In central London some coach services operate as bus services, as they have their own routes, timetables and bus stops. This information is not included in the iBus data, so the data should be collected by visiting the relevant service provider's website. Examples of some of the services found within central London are: Big Bus Tours, City Sightseeing, Golden Tours, Green Line and Oxford Tube.

2.3.5.1 Bus Journey Times

iBus data includes multiple journey times between each bus stop pair for each route. Individual bus journey times are averaged to create a mean observed journey time for each stop-to-stop section. Depending on the level of detail required from the model, compiling stop-to-stop journey times or full route journey times is acceptable. An iBus section covers the exit of one bus stop to the exit of the next, including the dwell time at the second bus stop.

Alternatively, where iBus data cannot be obtained, multiple repeat journey time observations should be collected for each route, during each peak period. Where more than one public transport service follows the same route, it is useful to undertake multiple journey time measurements for

48 <http://www.tfl.gov.uk/maps/>

each service to derive a service-specific average journey time. For further guidance on sample size refer to section [B2.3.2.1](#).

2.3.5.2 Bus Stop Usage and Dwell Times

Bus stop usage should be examined during site visits because the layout of a stop, as indicated on site drawings, is not always indicative of how it is used on street. It is useful to consider the interaction with general traffic or other buses that occurs when a bus is waiting at a stop, for example it can be observed whether approaching traffic can pass a stationary bus or whether they give way to oncoming vehicles. This can have an impact on road capacity, and hence journey time validation, for both private and public transport.

Similarly, in order to accurately replicate bus journey times it is important to account for the dwell times of routes using the stop. The dwell time can include passengers alighting, buses waiting due to driver rest stops, driver changeovers and extended layovers used to regulate a timetabled bus service. Depending on the model purpose and type, such as when carrying out dedicated pedestrian modelling, it may also be necessary to capture detailed information on boarding and alighting passengers.

iBus data measures dwell times for each specific bus route, for each full hour, giving a mean actual dwell time for each bus stop. The dwell time given in iBus data is for the destination stop for each section.

2.3.5.3 Bus Lane Usage

The distance at which a bus lane terminates before a junction should be observed during network familiarisation. Bus lanes influence the amount of available road space for general traffic. The methodology used to model bus lanes will vary according to the modelling software being used, and should be examined on a site-by-site basis. It is also useful to note the frequency and volume of buses, cyclists, motorcyclists and taxis using a bus lane especially as, within London, the hours of bus lane operation can vary by day of the week.

2.3.6 Cyclists

Cyclists should be included in any modelling work, especially in inner London, unless there is good justification for omitting them.

2.3.6.1 Cyclist Counts

The most straightforward data collection exercise for cyclists is manually classified counts, in which the number of cyclists can be counted for all movements. This approach is ideal for individual junctions, but more complex for multiple junctions. Cyclist flows are unlikely to balance between junctions, as cyclists can start and end their journeys at almost any point in the network. For further detail on collecting cyclist flows and routing, refer to Chapter **C2** on **Cyclist Modelling**.

2.3.6.2 Cyclist Journey Times

Analysis of cyclist journey times can help inform decision making for schemes to support the Mayor's Transport Strategy⁴⁹. Journey time data can be obtained from GPS fitness apps, although alternative methods are possible.

Observed cyclist data from GPS tracking typically provides cyclist counts and speeds by hour and direction across London. The data is transformed by TfL to align to Ordnance Survey's MasterMap Highways Network (formerly ITN). Highways Network edges represent the area of the network between junctions. The data can be aggregated to provide average travel times and counts by edge and hour for each month, as well as summing edges together between junctions. Median average travel times are used as they are less sensitive to outliers.

Any data obtained from GPS sources should be used for indicative purposes, as they may not be directly comparable to modelled data due to cyclist behaviour. This can be observed when some cyclists disregard red signals, which increases their speed between junctions.

2.3.7 Pedestrians

Pedestrian demand is not usually measured during traffic surveys for TfL unless detailed pedestrian modelling is to be carried out, or where there are significant informal or unsignalled crossings that affect vehicle behaviour.

49 Mayor of London, Mayor's Transport Strategy, March 2018

When examining UTC facilities an appropriate proxy for pedestrian demand is the appearance of pedestrian stages. The frequency of appearance can be obtained from UTC via demand dependency data, as described in **B2.3.8.5**, which can be used for calibration in each modelled period. For non-UTC junctions, the frequency of pedestrian stage appearances should be recorded during traffic surveys.

Toucan and Puffin crossings operate with on-crossing detectors, which allow pedestrian-to-traffic intergreens to vary between minimum and maximum values. The presence of these facilities should be determined during network familiarisation. Where they are operational it is necessary to gather information during traffic count surveys so actual timings can be interpreted to determine average stage and interstage durations. This data can be interpreted directly at Pelican crossings where pedestrian stages operate using fixed minimums as specified on Timing Sheets, however there is a requirement to calibrate the use of the flashing amber period by traffic.

It should be noted that some pedestrian crossing facilities can be operated using UTC timing plans with force bits (see **B2.3.8.3**). In those situations, it is possible for pedestrian stages to operate for longer than their minimums. It is possible for demand-dependent pedestrian stages to have forced demand (DX) within UTC plans, where pedestrian stages can be called without demand being present on street. This can be used for safety reasons or as part of a traffic management strategy. The timing plans of all pedestrian crossing facilities should be analysed to understand the UTC control method.

2.3.8 Signal Timings

Traffic modelling relies heavily on the accuracy of signal timings to correctly represent capacity at signalised intersections. This section briefly describes how signal timing data should be extracted to accurately reflect on-street operation.

Signal timing data must be captured at the same time as other traffic surveys, and should be recorded separately for each modelled period.

2.3.8.1 Basic Principles

Specific concepts and signal controller terminology should be understood prior to commencing a modelling project. Detailed background information on the basic principles of traffic signals are detailed in the Traffic Signs

Manual⁵⁰. The key terminologies which are applicable to this document include:

- **Phase** – A set of associated movements that are simultaneously controlled by the same traffic signal indication;
- **Phase Minimums** – The minimum amount of green time that can be allocated to each phase;
- **Intergreen** – The safety period between conflicting phases losing and gaining right of way;
- **Stage** – The period during which a group of non-conflicting phases all receive a green signal;
- **Stage Minimums** – The minimum period that a stage is required to run, in order to satisfy the minimum green requirements for all phases in the stage;
- **Interstage** – The period of time between the end of one stage and the start of the next stage, defined when all phases within the stage have received a green signal;
- **Phase Delay** – The adjustment of phase end or start times within the interstage period. These can be defined as Phase Losing delays, where a phase losing right of way is extended into the interstage period to maximise capacity, or Phase Gaining delays where a phase which gains right of way is delayed, generally for safety reasons;

It is important to note that controller manufacturers have different methods of defining the operation of phase gaining delays. When building a model it is important to note the controller manufacturer's details and how they document phase gaining delays to ensure phase timings are accurately reflected.

- **Cycle Time** – The time period required to complete the full sequence of stages in a signal timing plan;
- **Offsets** – The time displacement between phases or stages at adjacent signalised sites; and
- **Method of Control** – The collection of stages available to operate a junction in order to allow each phase to receive a green signal. This

can include optional contingency stages that cater for special traffic conditions.

The above list is based on UK signal terminology, however it should be noted that Aimsun Next uses alternative signal terminology which is defined in

Table 8 in Chapter B3 on Aimsun Next Modelling. Key signal information for a signalised site is contained within the site's Timing Sheet and Controller Specification documents, as described in B2.3.1.

2.3.8.2 Types of Signal Control

In general terms, the control of traffic signals can be split into two groups: Urban Traffic Control (UTC) and non-UTC. UTC coordinates the operation of junctions over an area through use of timing plans implemented by a central computer. Non-UTC signals operate under local control, where timings are stored locally on each controller and activated according to a pre-defined timetable.

UTC traffic signal control can be further classified into:

- **Fixed Time (FT)** – These facilities operate fixed signal timings via set plans that are changed by time of day; and
- **Split Cycle Offset Optimisation Technique (SCOOT)** – These facilities operate via an adaptive system that uses an algorithm to constantly optimise the green split, junction offset and region cycle time for a group of coordinated signals, based on local traffic demands.

Locally controlled, FT and SCOOT sites can all support demand-dependent traffic and pedestrian stages (covered in B2.3.8.5), which only appear if demanded by pedestrians or traffic requiring these stages. In the event of non-appearance the demand-dependent stage times can be reallocated to other stages, according to the pre-determined fixed plan structure in the case of FT sites and with the possibility of being more intelligently reallocated under SCOOT depending on local traffic demands.

Furthermore, System Activated Strategy Selection (SASS) and Selective Vehicle Detection (SVD) bus priority are dynamic signal control methods applied within the UTC system for traffic management purposes. When in operation they can trigger pre-determined traffic management strategies based on traffic levels, or vary signal timings according to bus arrivals. It should be determined whether SASS or SVD bus priority is present during network familiarisation. If they are active then it is advised that NP be consulted to determine the best approach for modelling, either to capture average signal timings or more accurately replicate dynamic UTC operation in a microsimulation model with a UTC interface (discussed further in B7.4.5.3).

The Surface Intelligent Transport Systems (SITS) programme began in 2014 and aims to respond to the future challenges that face London's road network. The Real Time Optimiser (RTO) will replace TfL's Urban Traffic

Control (UTC) system, it's SCOOT system and Fast-UTC functionality. The RTO system will contain both the SCOOT traffic signal optimiser and the Fusion optimisation algorithm, which will replace SCOOT through a gradual migration programme. The optimiser will behave differently to 'baseline' SCOOT and is able to consume richer data sources to make more intelligent, policy-responsive, multi-modal optimisation decisions. Strategy Manager (StratMan) is the component within RTO that will replace TfL's existing SASS functionality, which automates changes to the operation of traffic signals based on data, performance, and operational status of traffic signals.

2.3.8.3 UTC Junctions

The primary function of the UTC system is to transmit stage change events via timing plans to on-street controllers, which then adjust the amount of green time available for each stage. The UTC signal timing plan details the required stage sequence to be operated within the controller. To do this, the UTC system sends a request to the controller to change stage (force bit), and once the stage change has occurred the controller replies with a confirmation (reply bit). All signal timing plans follow a similar format, which specifies the target controller, the plan number, cycle time, and stage change event times. Closely associated junctions that are under SCOOT control can be grouped together within UTC timing plans (multinodes) to maintain safety-critical offsets, for example where parallel pedestrian streams are positioned on the exit to a junction.

The process used by NPD to extract on-street signal timings from UTC requires a skilled resource. It is beyond the scope of these Guidelines to detail the process required to manually calculate and audit derived signal timings. The exact approach requires prior knowledge of the UTC control type used to operate the signalised junction.

Fixed time signal timings can be extracted directly from UTC plans as these facilities operate using a constant cycle time with a repeatable sequence of stages and stage lengths. The interpretation of force and reply bit information can therefore be conducted once demand-dependent stage data has been captured, as described in section **B2.3.8.5**. Once all data has been collated it is necessary to translate the stage sequence, as defined by the signal timing plan, to understand where time has been allocated within an average cycle.

2.3.8.3.1 Average SCOOT Timings

It is possible to model full dynamic SCOOT behaviour in a microsimulation environment using TfL's UTC-Vissim interface, which provides full flexibility to test operational traffic management strategies. Where microsimulation models are not being used to replicate dynamic SCOOT behaviour, it is necessary to generate an average timing plan for each SCOOT junction. UTC timing plans must not be interpreted directly when SCOOT is in operation, since SCOOT is an adaptive system which optimises signal timings. Stage durations, offsets and cycle times are therefore able to fluctuate throughout the period being modelled.

To create an average plan, it is necessary to log dedicated SCOOT messages during traffic surveys. These allow the three variable elements (cycle time, stage length and offset) to be recorded for relevant signals, allowing the determination of representative average timing plans for modelling purposes. The following are typically recorded:

- Messages detailing the SCOOT stage pulse points and SCOOT node cycle times, commonly referred to as 'M16' messages;
- Messages detailing the offset between SCOOT stages in seconds, commonly referred to as 'M18' messages; and
- Messages detailing controller stage timings, including the preceding intergreen length and green duration in seconds, commonly referred to as 'M37' messages.

However, multinode relationships may exist within SCOOT to fix stage durations and offsets between separate nodes. Modellers should also be aware that the stage lengths recorded and displayed within M16 and M18 messages are the lengths of SCOOT stages rather than controller stages as defined in **B2.3.8.1**. For this reason, it is a necessary to analyse UTC signal timing plans to understand the relationship between UTC and SCOOT staging prior to extracting average SCOOT signal timings.

SCOOT has the capability to vary region cycle times for groups of coordinated signals, and can provide individual sites the opportunity to double-cycle compared to others in the group. Before collating cycle time information, it is necessary to establish whether any signalised facilities were single-cycling or double-cycling during the modelled period. The average cycle time for each SCOOT node can then be determined. The average controller stage lengths should then be calculated in proportion to the average cycle time, while noting any fixed-length stages defined in the plan. Average controller stage to controller stage offsets can then be calculated and applied for each modelled site according to the defined SCOOT / controller stage relationships.

2.3.8.4 Non-UTC Junctions

Non-UTC signalised sites are operated by the junction controller rather than a centralised system. These facilities are controlled using Cableless Linking Facility (CLF), Microprocessor Optimised Vehicle Actuation (MOVA) or Vehicle Actuation (VA).

CLF-controlled sites operate using timing plans stored locally within the controller. CLF control plans are detailed on Controller Specifications, which should be collated for all sites during network familiarisation. CLF plans are analogous to Fixed Time UTC plans, making it possible to extract average signal timings using a similar method to that described in [B2.3.8.3](#). It is advisable to check the accuracy of CLF timings derived from Controller Specifications with NPD, to confirm they are up to date and as running on street.

MOVA and VA allocate green times to different traffic movements between defined minimum and maximum limits. Vehicles detected by the controller during a green phase extend the green period until a gap exceeding a critical value is found, or the maximum is reached. MOVA expands upon VA control, by working in uncongested traffic conditions to disperse queuing and minimise stops and delays for traffic using the junction. Therefore, an approach will not extend its green time unless there is a benefit to the whole junction. In congested conditions, MOVA optimises the signal timings to maximise junction throughput while taking account of oversaturated approaches. MOVA and VA signal timings are not based on structured plans and there can be many different phasing and staging arrangements. When modelling MOVA or VA junctions, further advice should be sought to ensure that operation of the junction is correctly interpreted. In some instances, it may be possible to obtain signal timing logs from these sites directly from the controller, however it is more common that average green times will need to be observed on street. If possible, replication or close approximation of full MOVA or VA behaviour and functionality in a microsimulation model is preferable to use of average timings.

2.3.8.5 Demand-Dependent Stages

A signal controller registers the presence of on-street demands when activated by vehicle detectors or pedestrian push-buttons, and ensures that the stage containing the relevant demand-dependent phase will be called at the next available opportunity. An opportunity for demand to be served is determined by the stage sequence embedded within the controller logic (in the case of VA or MOVA) or signal timing plan (in the case of UTC or CLF). The number of opportunities available for a demand-dependent stage at UTC or CLF-controlled sites is broadly based on the signal timing plan structure and overall junction cycle time. When a demand-dependent stage does not appear within a cycle the unused time will be allocated to one or more stages as defined within the signal timing plan. It is important to understand the signal timing plan structure to determine how the unused time is reallocated to alternative stages.

The UTC system monitors and records the appearance of demand-dependent stages, which can be analysed in 15-minute increments over each 24-hour period. The monitored counts provide the number of demand-dependent stage opportunities against the number of actual stage appearances. It is worth noting that the number of available stage opportunities may be variable under SCOOT control when a node is free to single-cycle or double-cycle. Advice from NPD should be sought if a node has the potential to single-cycle and double-cycle within one monitoring period, as additional cycle time data will need to be captured to calculate the correct number of available stage opportunities.

Demand-dependent stage frequency data for UTC sites can be requested from AssetOperationsDataLegalRequest@tfl.gov.uk. Demand dependency data is not available for sites under local control and will have to be measured on site.

2.3.8.6 Flared Approaches

A flare represents a lane at a stopline that is fully used for only a portion of the green time, even during fully saturated conditions. A flare therefore only contributes to stopline capacity for a limited period at the start of green, after which it provides no further benefit.

A flare can be physical (increased road space due to widening of the carriageway before a stopline), or effective (for example through termination of a bus lane or parking area before the stopline). Flares are a common source of modelling error; therefore, consideration should be given to if and how they should be modelled.

Flare length utilisation must be considered according to the proportion of vehicles using the flare, and models need to be calibrated so that flare usage reflects observed data recorded on site, as described in [B2.3.2](#). Further guidance on flare layouts and calibration can be found in the software-specific chapters within [Part B](#).

2.3.8.7 Non-Green and Flashing Amber

The time used by traffic during non-green or flashing amber periods can influence road capacity and this should be recorded on site and accounted for during model calibration. Additional capacity created by aggressive vehicle behaviour can be recreated within a traffic model but must be based on recorded evidence and identified for audit.

Non-green periods should be accounted for if vehicles are observed on site to behave aggressively at the stopline, for example by accelerating during the starting amber period or crossing a stopline after the start of red. Site observations should record the total time (in seconds) utilised by traffic during non-green periods for each peak period, although usage during the leaving amber period is expected and should therefore be treated as green, unless usage is being recorded separately for each non-green period. For Pelican crossings, traffic usage during the flashing amber period should also be recorded (in seconds) during site observations for each peak period being modelled. A good sample is needed to demonstrate confidence in the model results. For further guidance on data collection refer to section [B2.3.2](#).

2.3.9 Saturation Flow

Saturation flow represents a key measurement of on-street capacity and thus the values used within a model must accurately reflect the built environment to correctly model junction performance.

Saturation flow, measured in PCU/hr, can be defined as:

“...the maximum flow, expressed in equivalent passenger car units, that can be discharged from a traffic lane when there is a continuous green indication and a continuous queue on the approach.”⁵¹

Saturation flow is an expression of the maximum capacity of a lane and is predominantly determined by junction characteristics (including geometry, layout, turning radii and visibility). The saturation flow input for a model should generally not be altered between models or modelled periods unless physical characteristics are modified, such as changes within a Proposed model. Saturation flows should only be altered for each time period where a lane shares more than one turning movement, and site observations have noted that flow patterns vary significantly across the day. In addition, for deterministic modelling, saturation flows may need to be reviewed across different peak periods if there is a significant change to the vehicle class proportion, such as an increased proportion of heavy goods vehicles.

Saturation flows are normally required for each individual lane that is modelled, although multiple lanes can be combined into a single measurement where modelled as a group, if they perform identically in terms of flow, vehicle destination and queuing behaviour. However, this also depends on the proposed use of the model – if, for example, lane usage is expected to change as a result of bus lanes, smart lanes or lane destination (arrow / marking) changes, then it would be necessary to measure each lane separately. If there are any doubts regarding proposals, and time allows, then each lane should be measured separately.

Where fully saturated traffic appears to discharge at a rate less than the saturation flow, such as due to driver behaviour or exit-blocking, this should not be accounted for by changing the saturation flow in a model. This behaviour is not always apparent to an observer when viewing traffic. Therefore, it is recommended that Underutilised Green Time (UGT) is measured to identify and quantify this behaviour, as explained in **B2.3.10.1**.

It is important that saturation flows are measured accurately. Incorrect saturation flows represent a common source of error which can cause delay during model development and auditing. A good sample is needed to

51 Salter R J & Hounsell N B, Highway Traffic Analysis and Design, 3rd Ed, Macmillan, 1996, p292

develop confidence in the model results, and it is recommended that the minimum length of each measurement should be 12 seconds⁵². Refer to section **B2.3.2.1** for further information on sample sizes.

Measurements should be conducted while vehicles are discharging across a stopline in free-flow conditions, and thus unaffected by downstream interference such as congestion or exit-blocking. Conditions need to be sufficiently busy that the link is saturated for an adequate period to allow measurement. The surveyor must be able to recognise the end of saturated conditions during each cycle. In some cases, due to insufficient flow or short green periods, it will not be possible to measure a minimum of 12 seconds of saturated conditions at any time of day. In these circumstances shorter measurements can still be recorded but should be identified in accompanying reports for the MAE, and their validity should be scrutinised by the CE before a MAP submission.

Saturation flow measurements should not include periods of 'lost time' at the start and end of green, as these represent time during which vehicles are accelerating or decelerating and therefore not moving at saturation flow. 'Lost time' parameters can be calculated, but it is unlikely exact values will be known unless recorded using a dedicated survey. It is therefore acceptable to use a default of two seconds start lost time and no end lost time. A common technique to account for start lost time is to ignore the first two vehicles to cross a stopline before recording saturation flow measurements. This prevents accelerating vehicles being counted towards measurements and causing underestimation of the saturation flow.

Situations may occur where satisfactory saturation flow measurement is not possible, for example due to insufficient traffic flows, green time or queuing. These should be assessed on a case by case basis and identified along with an explanation, including the reason why measurement was not possible and the alternative method used to estimate the saturation flows. An common method for estimating saturation flow based on TRL's Research Report 67 (RR67) is explained in the next section.

Careful consideration should be given to saturation flow measurements where cyclists are present on street, either in segregated or non-segregated facilities. For guidance on appropriate methodologies for collecting saturation flows including cyclists, refer to Chapter **C2** on **Cyclist Modelling**.

52 Binning J, Traffic Software News, TRL, September 2007, No. 43, p2

2.3.9.1 Use of Calculation Formula RR67

A method for predicting saturation flows using a standard formula was developed by the UK's Transport and Road Research Laboratory and published in its Research Report 67 (RR67).⁵³ This was based on analysis of empirical data collected at 64 sites spread across the UK, including 13 in London. RR67 allows saturation flows to be estimated based on geometric data such as vehicle turning radii, lane width and road gradient.

The use of RR67 can be necessary where it is not possible to measure saturation flows on street, such as for new proposals, where stoplines are frequently exit-blocked or where short green times or insufficient traffic queues prevent adequate measurement. Where congestion prevents measurement at a particular time of day it may however be possible to measure saturation flows for affected stoplines outside of congested periods.

While it may sometimes be considered appropriate to use RR67 for some non-critical stoplines, it is generally expected that saturation flows should be measured on street wherever it is possible to do so. Where it is not considered possible for measurement to be carried out at a specific location, an explanation should be provided in accompanying model reports.

When using RR67, it is important to be aware of the limitations of this approach and any calculated values should be used with caution. If critical modelled saturation flows are not accurate, they are likely to result in modelling discrepancies when trying to validate the model.

Data used in the development of RR67 was restricted to sites classified as 'good' or 'average' in terms of junction performance as defined by Webster and Cobbe⁵⁴, with 'poor' locations excluded. A summary of the characteristics for these classifications are provided in **Table 4**.

Given the numerous sources of interference for traffic in London, such as heavy pedestrian movements, poor visibility and parked vehicles, many junctions would fail to meet the 'good' or 'average' classifications assumed by RR67. Use of the RR67 formula can therefore result in overestimation of saturation flows at many signalised junctions in London. A detailed study carried out by TRL in 2012 for TfL found that RR67 overpredicted saturation

53 Kimber R M, Macdonald M & Hounsell N B, The Prediction of Saturation Flows for Road Junctions Controlled by Traffic Signals, Transport and Road Research Laboratory, Department of Transport, Research Report 67, 1986

54 Webster F V & Cobbe B M, Traffic Signals, HMSO, Road Research Technical Paper No. 56, 1966

flows by an average of 15% in London compared to site-measured values.⁵⁵

Table 4: Junction performance classifications based on Webster & Cobbe⁵⁴ and updated by TRL⁵⁶

Classification	Characteristics	Example
Good	No interference from: <ul style="list-style-type: none"> • pedestrian activity • parked vehicles • opposed turning traffic • downstream congestion • upstream / downstream minor side roads Good visibility Adequate turning radii Good junction alignment Good exit width Good quality road surface	Dual carriageway
Average	Some characteristics of good and poor sites	-
Poor	Some interference from: <ul style="list-style-type: none"> • pedestrian activity • parked vehicles • opposed turning traffic • downstream congestion • upstream / downstream minor side roads Poor visibility Poor junction alignment Poor exit width Poor quality road surface Low average speed Traffic calming measures on entry or exit	Busy shopping street

Where RR67 is applied it is recommended to verify estimated values

55 Emmerson, P, Crabtree, M, Gibson, H, The estimation of saturation flows at traffic lights in London, and the impact of cyclists on saturation flows, Transport Research Laboratory, December 2012

56 <https://trlsoftware.com/support/knowledgebase/saturation-flow-food-for-thought/>

against measured data where possible. A factor should be calculated that accounts for local junction characteristics as compared to the 'typical' junction inherently described by RR67. This factor should be generated by calculating the RR67 predicted saturation flow for a similar stopline at the junction where measurement is possible and comparing against the measured value. This adjustment factor should be applied to predicted values for relevant approaches where measurements are not possible or practical.

Where there is difficulty in calculating an appropriate adjustment factor, an alternative 'rule of thumb' proposed by TRL⁵⁹ suggests:

- For 'poor' sites, reduce RR67 predictions by 15-25%;
- For 'average' sites, reduce RR67 predictions by 5-10%; and
- For 'good' sites, increase RR67 predictions by 10%

Whichever approach is used, any RR67-adjusted saturation flows should be highlighted in accompanying reports with appropriate justification for the MAE and audited by the CE during model calibration.

2.3.10 Degree of Saturation

Degree of saturation (DoS) is a key parameter for validating traffic models. We recommend that all those who measure DoS have a thorough understanding of the concept and how to accurately measure it on site. Intrinsic to this understanding is knowledge of the different factors that can influence DoS, both on site and in a model. This section describes the methodology required by TfL for measuring DoS. The method is designed to account for Underutilised Green Time (UGT), as defined in **B2.3.10.1**, which can be calculated from DoS measurements.

A DoS survey should be conducted on all critical approaches for each modelled period. Critical approaches would include those close to saturation, those that determine stage length and those key to scheme proposals. In order to achieve an overall measurement that is representative, data sampling should be distributed across the whole of each period during which DoS is being measured. As described in **B2.3.9**, multiple lanes can be combined into a single measurement only if they are modelled as a group and if they behave identically in terms of flows, destination and queuing. They should not be combined if lane usage is expected to change in Proposed modelling. If there are any doubts regarding proposals, and time allows, then DoS for each lane should be measured separately. For guidance on including cyclists in DoS collection, refer to Chapter **C2** on **Cyclist Modelling**.

2.3.10.1 Underutilised Green Time

Underutilised Green Time (UGT) corresponds to the number of seconds of effective green time within a signal cycle where saturation flow is not achieved, despite the presence of high demand (sometimes known as 'full' demand). High demand is defined as occurring when traffic is continuously passing or attempting to pass the stopline during a green period. UGT is measured in seconds per cycle and is calculated from data recorded during DoS measurement.

UGT is comprised of two elements:

- **Wasted Green** – which describes the period of a cycle during which an approach experiencing high demand receives a green signal, but traffic is unable to progress across the stopline (for example due to downstream exit-blocking); and
- **Sub-Saturation Flow** – which describes the period of a cycle during which an approach receiving a green signal does not fully utilise available capacity despite continuous demand, for example where vehicles fail to achieve the expected saturation flow. This effect can be caused by a number of factors such as signal offsets, downstream congestion or driver behaviour being influenced by issues including interaction with pedestrians, cyclists, buses, large vehicles, zebra crossings, parking, loading, or downstream lane markings.

At times traffic experiencing sub-saturation flow may only be travelling marginally slower than would be the case during unrestricted saturation flow. This may not be noticeable to an on-street observer, but its impact can be captured by calculating UGT following an appropriate DoS survey. UGT is calculated to quantify situations where congestion-related issues prevent discharge at an uncongested saturation flow. It is derived in a form that can be directly applied to available green time in traffic models such as LinSig or TRANSYT by using dummy staging, phase lags and/or bonus greens. It is important to record the potential causes of UGT, as this will determine how UGT values are to be dealt with in Proposed models.

If a negative UGT value is encountered, it indicates that the initial saturation flow measurement was inadequate and that further measurements are required. A negative UGT value highlights that traffic has been observed to discharge at a rate greater than the previously measured saturation flow during the DoS survey.

Figure 11 illustrates a flow profile measured on street for a lane in two different scenarios. The blue curve shows a flow profile for a stopline during uncongested conditions. The orange curve shows a flow profile for

the same stopline, but under congested conditions. The shaded area between the curves therefore represents the reduction in flow across the stopline due to congestion.

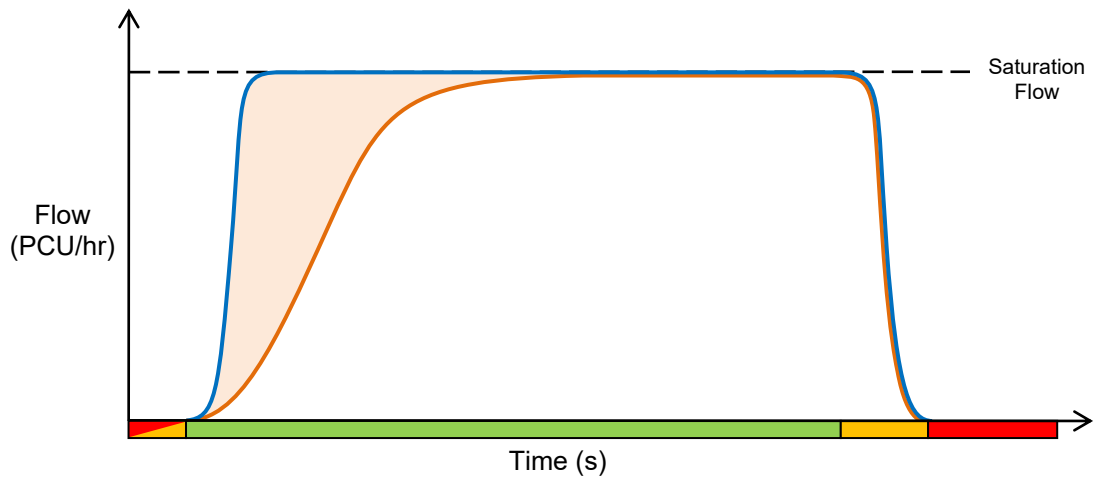

Figure 11: Flow profiles showing 'normal' (blue) and 'congested' (orange) conditions

Figure 12 illustrates how the shaded area, equal to that in **Figure 11**, represents the difference in capacity as accounted for by UGT (the time period during which full saturation flow was not achieved). It also illustrates how these scenarios will be modelled within deterministic traffic models such as LinSig or TRANSYT. UGT calculations are unable to discriminate between time periods where vehicles are 'slow moving' or where vehicles are stationary. This imitates deterministic traffic modelling software such as LinSig or TRANSYT, where vehicles are also assumed to be either stopped or moving at a saturated rate of discharge.

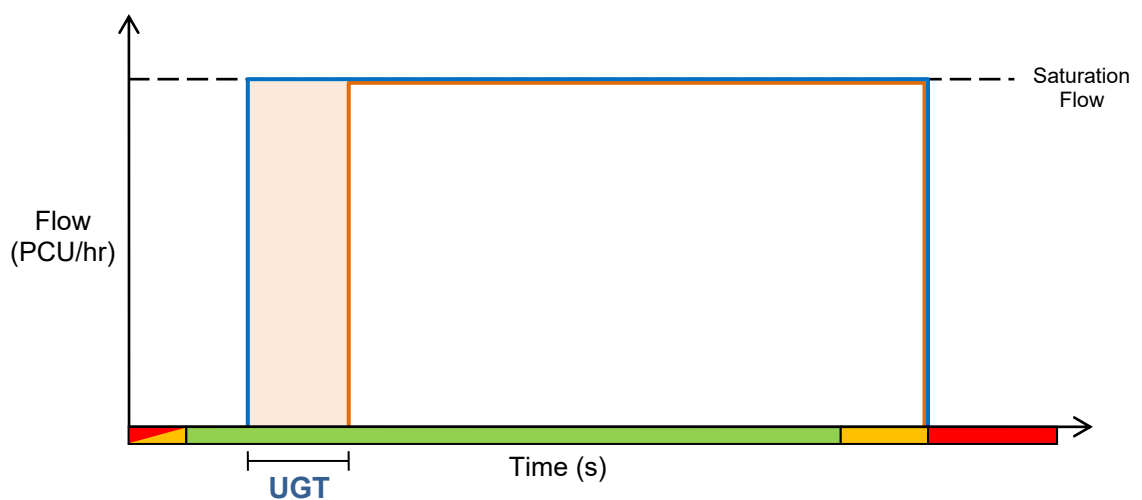

Figure 12: Congested conditions as modelled in LinSig or TRANSYT with UGT

It is advisable to apply UGT to model the effects of congestion, as this technique avoids the need for a modeller to iteratively adjust the saturation flow in a model during calibration and provides quantifiable evidence to justify the approach taken. Whilst it is possible to reduce the modelled saturation flow to achieve an effect analogous to the application of UGT, as shown in **Figure 13**, it is theoretically unsound as the applied saturation flow no longer represents the maximum rate of discharge across a stopline. If the length of effective green time is amended in a Proposed model, the adjusted saturation flow may therefore no longer be appropriate for the extended or reduced green time.

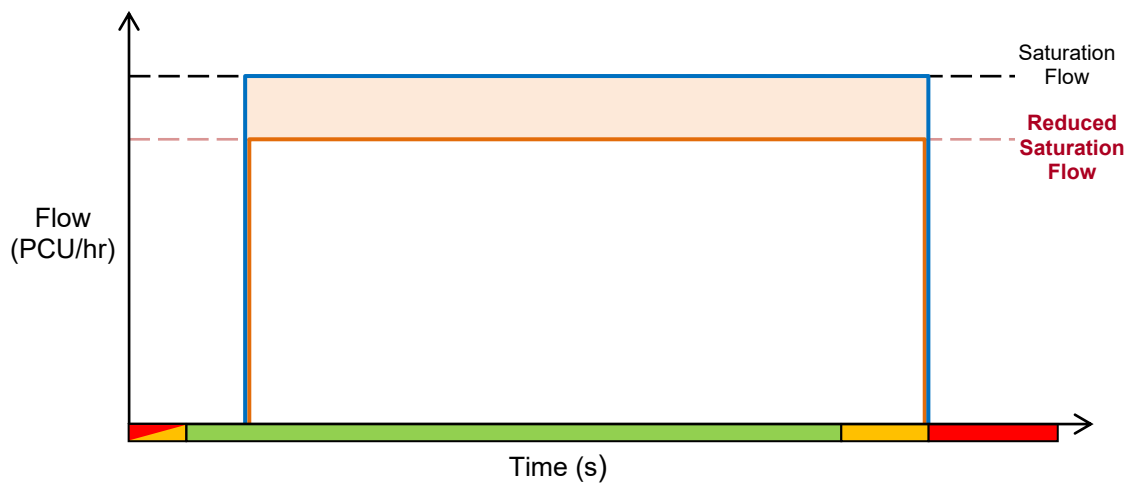

Figure 13: Incorrectly reduced saturation flow analogous to UGT applied in Figure 12

For further details on the calculation of UGT values using data recorded during DoS measurements, refer to **Appendix I**.

2.3.10.2 Measuring DoS

To calculate DoS the surveyor is required to measure the period of high traffic demand. Recognising high traffic demand can require experience, as at times a gap may develop between vehicles even though high demand is still present. This may occur where approaching traffic slows down before reaching a discharging queue, or where queued vehicles accelerate at different speeds. The definition of high demand and low demand periods is detailed below:

- **High Demand** – when a stopline with a green signal has more than two vehicles influencing each other's behaviour at the stopline. This would include discharging in a continuous platoon of vehicles, causing another vehicle to brake, queuing to cross a stopline, or waiting to exit a junction; and

- **Low Demand** – when vehicles behave independently and not as a single platoon of vehicles, commonly this will mean they can approach and cross a stopline without needing to brake for other vehicles.

Examples of high and low demand are shown in **Figure 14** and described in **Table 5**.

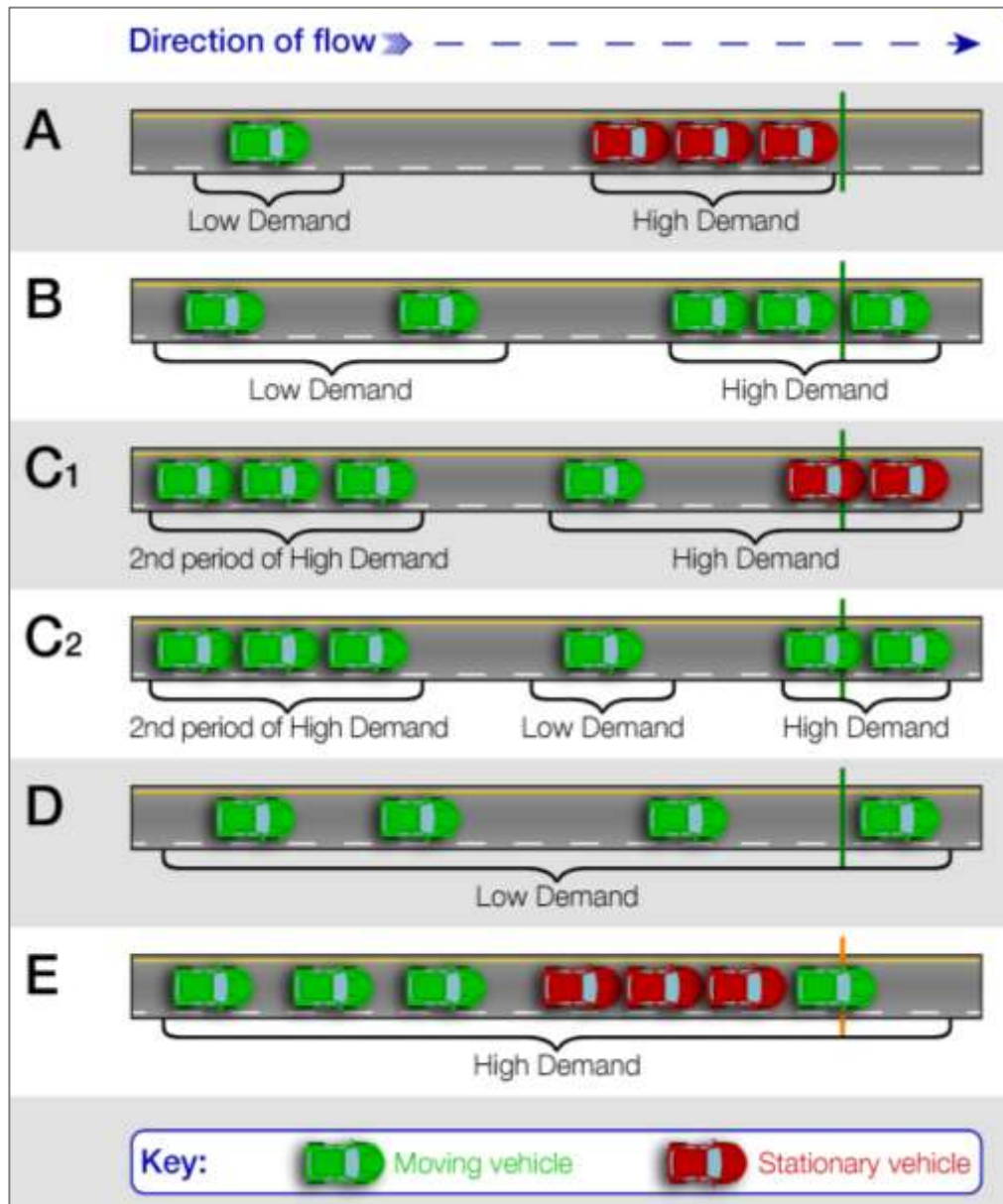

Figure 14: Diagram indicating periods of high and low demand

Table 5: Classifications for high and low demand examples shown in Figure 14

Scenario	Description
A	A queue of three stationary vehicles at the start of green will discharge under high demand, the single vehicle will arrive once the platoon ahead has discharged and will be classified as travelling across the stopline under low demand.
B	A platoon of three vehicles arrive at the stopline together creating high demand, two further vehicles arrive independently as low demand.
C1	Vehicles have a green signal but are waiting for the junction ahead to clear and are therefore creating high demand. A single vehicle then arrives on its own followed by a second platoon of vehicles arriving together. The isolated vehicle will begin to slow down due to the queue ahead and is therefore combined into the high demand period. Depending upon whether the queue at the stopline has cleared the second platoon will join the same period or form a new period of high demand.
C2	A similar situation to C1 but the vehicles ahead are beginning to clear the junction meaning the isolated vehicle will no longer be influenced by the queue and will therefore create low demand. As the situation is now free flowing the second platoon will form their own period of high demand when they reach the stopline.
D	All vehicles behave independently and are therefore classed as low demand.
E	Vehicles have begun to discharge from the stopline but approaching vehicles will join the queue or be delayed, forming a single unit of high demand.

It should be noted that the contribution of any short lane flare towards the duration of high demand at the start of the signal cycle should not be included.

The surveyor is required to record the time from the beginning of each period of high demand (this is from the start of green if a queue is present) until the end of high demand, during which they record the number of PCUs that cross the stopline. The end of high demand occurs when there is no further traffic queuing or flowing continuously at the stopline. The surveyor then records the number of PCUs that cross the stopline during

any subsequent periods of low demand. The number of PCUs must be recorded separately during each period of differing demand type. Finally, the total length of the green period should be recorded.

If additional periods of high or low demand occur after the end of the first periods of high or low demand (possibly due to a second vehicle platoon arriving as a result of a closely coordinated offset), these should be recorded separately and added to the first periods of high and low demand in calculations (both in terms of high demand duration and PCUs crossing the stopline during the additional high and low demand periods). If in doubt about whether an apparent second period of high demand is fully saturated (for example where gaps may be seen), it is better to assume it as low demand.

In summary the following information should be recorded:

- Time at start of green;
- Time at start of high demand periods (if different from start of green);
- Number of PCUs crossing the stopline during high demand;
- Time at end of high demand periods;
- Number of PCUs crossing the stopline during low demand; and
- Time at end of green.

For further advice on the number of DoS measurements to be recorded, refer to section **B2.3.2.1**.

2.4 Base Model Development

The initial step in any modelling assessment is to build a model replicating the existing on-street traffic conditions at a given point in time. This Base model presents a baseline that can be used for comparison against Proposed scenarios. A Base model is created for each time period that requires assessment. By comparing results between the Base and Proposed situation, an informed decision can be taken on whether to proceed with the proposal based on its predicted impact.

The process for developing a Base model is detailed in [Figure 15](#). The model purpose should be discussed at the onset of a modelling project as part of the Base scoping meeting described in [B2.1.5.1](#). At this meeting key elements of the modelling project are discussed and agreed, as explained in [B2.2](#). The agreed modelling requirements are subsequently documented in the Modelling Expectations Document for later reference, which is detailed in [B2.1.5.2](#).

Following a period of on-site data collection, detailed in section [B2.3](#), the Base model is updated and refined as part of the calibration and validation process (sections [B2.4.1](#) and [B2.4.2](#)). Once the software-specific validation criteria have been met and the model has been audited as part of the MAP process, as described in [B2.1.5](#), it can be used for the assessment of future scenarios. Within the Three Stage Modelling Process, covered in [B2.1.4](#), the development of a Base model involves production of deterministic, microsimulation and tactical models, and may involve interaction between the modelling levels as detailed in [Figure 10](#).

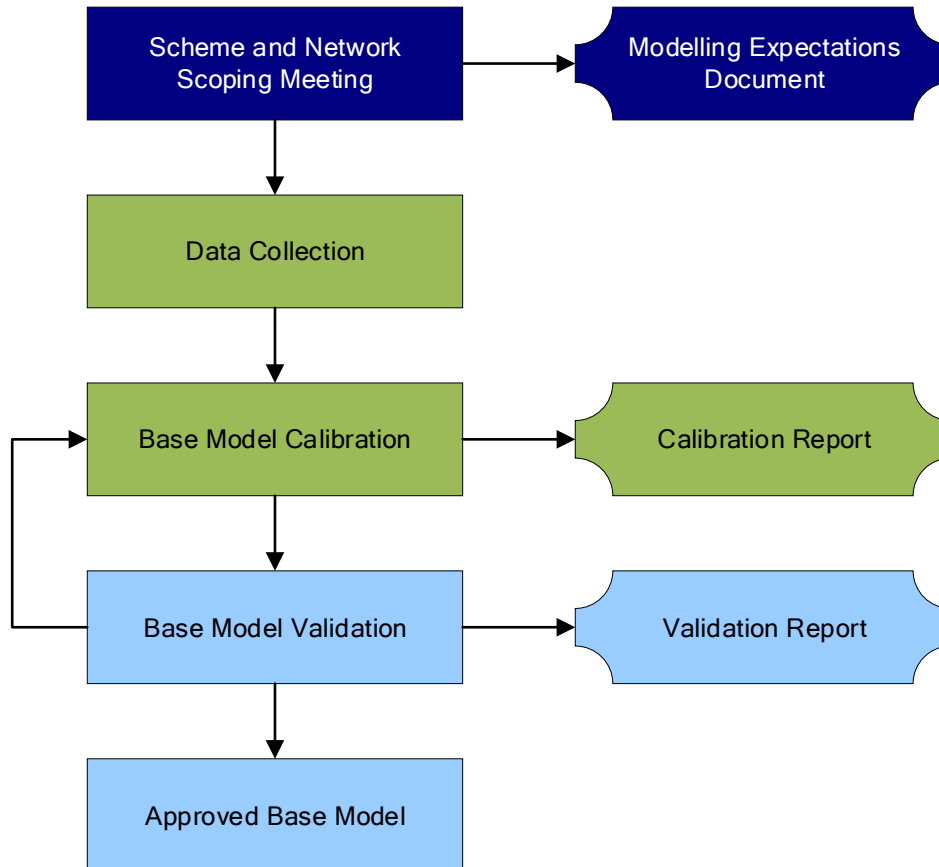

Figure 15: Schematic diagram outlining a generalised approach to Base model development for TfL

2.4.1 Base Model Calibration

Traffic models are as accurate as the calibration process undertaken during development. The most appropriate techniques for model calibration should be carefully considered, as accurately validated models form the basis for Proposed modelling.

The purpose of the calibrated model submission during MAP Stage 2 **(B2.1.5)** is to allow the developer and any model auditor to assess model structure, and the validity of initial input data. At this stage it is possible to identify and resolve issues that may otherwise hinder further model development. For this reason the calibrated model should be accompanied with tabulated data that clearly emphasises model inputs and how they were derived from measured sources.

Calibration describes the process of placing measurable data into a traffic model to replicate observed street conditions. All input data for

calibration should be auditable, such as signal timings and on-street measurements (for example lane distance, cruise times and saturation flows). It is usual for this information to have been collected from on-street measurements as described in section **B2.3.2**. Calibration may require adjustment of model parameters to recreate observed behaviour, and for this reason the calibration process should be applied to each period being modelled.

MAP Stage 2, described in **B2.1.5**, defines the requirements necessary to generate a calibrated model. Refer to the individual software-specific chapters within **Part B** for detailed Base model calibration guidance.

2.4.2 Base Model Validation

Validation is the process of comparing model output against independently measured data that was not used during the calibration process. The purpose of validation is to verify that a model has been correctly calibrated, and that there is therefore confidence in its ability to produce valid predictions for Proposed scenarios.

As the overarching aim of validation is to produce a model that is fit for purpose, it is necessary to choose validation parameters that are relevant to the purpose of the model. The model developer should therefore agree suitable validation parameters (such as bus or cyclist journey times) at an early stage of model development and ensure they are recorded at the appropriate time, coinciding with site visits or traffic surveys where possible. Ideally the model developer should be actively involved in on-site data collection, to be satisfied that street conditions represent those which are to be replicated in the traffic model. Common validation parameters such as degree of saturation and journey times are used to show confidence that calibrated model results accurately reflect observed on-street behaviour. Queue lengths are generally not used for validation purposes due to the difficulty in measuring them on street, however comparing modelled levels of queuing to those observed on street can indicate where inaccuracies may exist in a model.

Validation criteria are used to demonstrate that modelled results fall within an acceptable tolerance of observed data. These criteria vary according to the modelling software used and are detailed both in MAP and relevant software chapters contained within these Guidelines. If a model fails to validate it is often an indication that poor data collection practices were adopted or that further model calibration is required. Results for the validation exercise must be taken from a model that accounts for measured demand dependency (**B2.3.8.5**) and the effects of

UGT (**B2.3.10.1**). Validated deterministic modelling and microsimulation models are submitted during MAP Stage 3, as described in **B2.1.5**.

2.5 Proposed Model Development

Proposed model development incorporates the proposal details into the modelling assessment process. Where the Three Stage Modelling Process outlined in **B2.1.4** is being followed, Proposed model development will include the creation of both a Future Base model and a Do Something model. These traffic models are used to analyse and assess the detailed impacts of the proposals so that an informed decision can be made on whether to implement them on street.

The process for developing Proposed modelling is detailed in **Figure 16**. The Proposed modelling process begins with a Proposal Scoping Meeting, to revisit and review the scheme proposals and to agree the Proposed modelling methodology, as described in **B2.1.5.1**. Following this meeting the Modelling Expectations Document should be updated to capture any changes, as described in **B2.1.5.2**.

Proposed models are modified versions of validated and approved Base or Future Base models. Any changes to the Base or Future Base model should be limited to the minimum required to represent the proposal, while ensuring that the model accurately reflects any changes which form part of the scheme. It is common for Proposed modelling to require interaction between different levels of modelling, as described in section **B2.5.5**. Once the Proposed modelling is approved, model outputs should be analysed and reviewed in detail.

On completion of Proposed modelling, reports should be produced to document the Proposed modelling methodology, as described in **B2.6**. NPD will use modelling outputs and analysis to make an informed assessment of the likely impacts of the scheme, and give recommendations to NIST in the SIR (described in **B2.6.5**).

As any proposal is a forecast there is no observable data to validate model outputs against. The validity of a Proposed model is therefore verified by analysis of the approach taken by the model developer, confirming that modelled adjustments from Base / Future Base models are appropriate and through scrutiny of Proposed model outputs.

Figure 16 illustrates the iterative process of using Proposed model results to analyse the predicted impact of scheme proposals. Modelling and/or scheme proposals can then be updated and reassessed as necessary, depending on the impacts predicted.

The remainder of this section details the processes undertaken to ensure that Proposed models are considered fit for purpose.

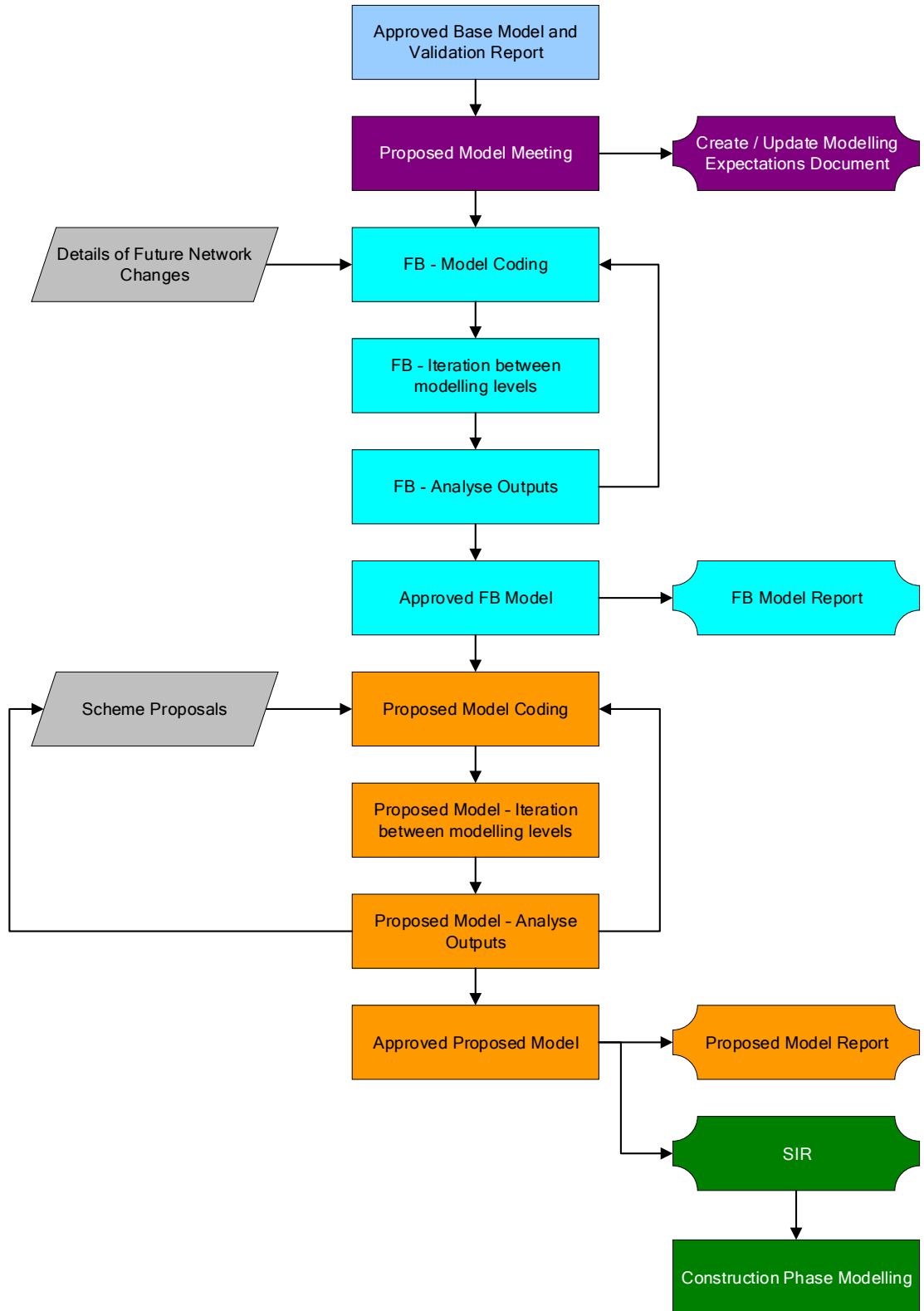

Figure 16: Schematic diagram outlining a generalised approach to Proposed model development for TfL

2.5.1 Future Base

The Future Base model represents the future year in which the scheme under consideration is planned to be implemented but does not include the scheme itself, as explained in **B2.1.4.2**. The key difference between building the Future Base and Do Something models is the addition of the scheme proposal.

A Future Base model is required for all schemes that are assessed using the Three Stage Modelling Process detailed in **B2.1.4**. The requirement for a Future Base model should be discussed and agreed at the Base scoping meeting described in **B2.1.5.1**. At the time of publishing, there is no dedicated MAP stage for Future Base models, however as the process of building a Future Base model is related and similar to that required to build a Proposed model, they should be developed and audited as part of MAP Stage 5, as outlined in **B2.1.5**.

To create a Future Base model, the approved Base model is updated to include any future network changes planned for implementation up to the future year being assessed. Schemes are included using the latest proposals available at the time of Future Base model development, and may be subject to change at a later date. The schemes to be included in a Future Base model, together with their current proposals, should be agreed at the Base scoping meeting. Any changes to the Base model should be limited to the minimum required to incorporate the planned future year changes.

The traffic flows in the Base modelling are likely to require updating to reflect the Future Base demand in the future year being modelled, which is covered in more detail in **B2.5.2.2**.

The guidance in **B2.5** applies equally whether creating the Future Base scenario or the Proposed scenario.

2.5.2 The Scheme Proposal

The Proposed model represents the year in which the scheme under consideration is planned to be implemented, and contains relevant changes to include the scheme itself. It is based on either the Base or Future Base models, depending on whether the Three Stage Modelling Process described in **B2.1.4** is being followed. The scope of a scheme proposal can vary from a minor adjustment of signal timings at a single site to a complete redesign of junction layouts and methods of control across a wide area.

Every proposal is unique, and it is beyond the scope of this document to list all the parameters that may need adjustment. It is the responsibility of the model developer to determine the changes that are required and to justify any applied methodology. Proposed changes that may need to be accounted for within a traffic model include:

- Physical road layout and geometry;
- Lane markings and usage;
- Saturation flows;
- Methods of control at signalised junctions;
- Signal timings;
- Signal staging;
- Signal hardware;
- Traffic flows;
- Traffic compositions;
- Effective flare usage;
- Demand-dependent stage frequencies; and
- Reassignment.

When producing a Proposed model it is important to consider the traffic management objectives of the scheme. Whilst overall network performance measures should be considered, these should not override considerations detailed in [A2.1](#) such as local policy requirements or the Mayor's Transport Strategy⁵⁷.

2.5.2.1 Changes to Junction Design

Modifications to junction designs or methods of control may typically require recalculation of phase minimums and phase intergreens. When calculating these, reference should be made to TfL's SQA-0640 document series^{ll}, which is covered in [A4.5.2.1](#) and details design standards for traffic signals in London. Of these, SQA-0644, details pedestrian minimum and intergreen timings for standalone pedestrian crossing facilities. Calculation of traffic phase intergreens must be undertaken in accordance with SQA-0645, which also covers minimums and intergreens for pedestrian phases at signalised junctions. Before any modelling can commence the proposed designs must be signed off by the SAE.

Layout changes within a proposed design may also impact saturation flows. Where existing saturation flows are affected by new issues such as pedestrian movements or parking, the impact of these should be

57 Mayor of London, Mayor's Transport Strategy, March 2018

accounted for in saturation flow values used within Proposal modelling. Where possible, saturation flows should be estimated using RR67 for the Base model geometry (section **B2.3.9.1**) and compared to the Base site-measured value. An appropriate factor for that approach can then be determined to apply to estimated RR67 values based on the proposed geometry.

It is recommended that changes to geometric inputs are assessed by processing a version of the Proposed model incorporating just these changes, before applying changes to signal timings or traffic flows. This will indicate a rudimentary estimate of the impact of physical design changes on the performance of the study area.

A Proposed model should supply junction design information to a level of detail that allows the production of a Controller Specification. In order to reconcile phase-based signal design with stage-based minimums and interstage design it is recommended to use junction design software such as LinSig, and to supply these models with any submitted proposal. Inclusion of these controller models within a proposal provides a clear indication of how stage minimums and interstage designs were calculated and optimised.

Where critical offsets exist within a Base model, such as at closely associated junctions or SCOOT multinodes, it is vital that these are coded accurately. Any fixed relationships should be audited to ensure correct groupings are carried forward into any proposal.

Consideration should always be given to pedestrian linking during junction design. Pedestrian progression through a junction can be assisted by linking pedestrian phases, for example using an associated parallel stage stream pedestrian crossing. Designers should be mindful of optimising phasing and interstage design to maximise opportunities for pedestrians to move smoothly through the network.

2.5.2.2 Changes to Traffic Flow

Proposed modelling should represent any significant changes to traffic flows or flow patterns which are expected to occur as a result of a proposal. The Three Stage Modelling Process uses tactical models to account for traffic reassignment, which can be applied to deterministic and microsimulation models as illustrated in **Figure 10**. Interaction between these modelling levels is covered in more detail in **B2.5.5**. Where the Three Stage Modelling Process is not being followed, there may be a requirement to manually edit flows to account for the introduction or banned turning movements or the addition of development traffic. The methodology to

model Proposed flows should be agreed at both the Base and Proposed scoping meetings described in **B2.1.5.1**.

Where cyclists have been included in modelling, the process for obtaining Proposed cycle flows could be achieved by factoring existing cycle flows while maintaining cycle routing from the Base models. Alternatively, Proposed cycle flows and routings could be informed from the Cynemon model, which is described further in **B5.2.1** and **C2.2.3**.

Flare usage should be estimated based on the Proposed flow changes. Some modelling software has functionality to account for this, or alternatively the standalone JCT software LinSat can be used⁵⁸. Where flows are unchanged, flare usage should not be changed from the calibrated values held within the validated Base model.

2.5.2.3 Demand Dependency Adjustments

The validated Base or Future Base model on which the Proposed model is based is likely to have been calibrated with demand-dependent stages appearing for only a proportion of the total cycles modelled. This will have been based on observed data and may be modelled using proxy adjustments such as ‘bonus greens’, dummy stages or reduced stage lengths. If the cycle time is changed in the Proposed model, then the number of demand-dependent stage appearances may need to be adjusted to account for the change to the total number of cycles per hour that will be modelled. Similarly, if the cycle time does not change but demand (either pedestrian or vehicular) is expected to change then consideration should be given to whether the frequency of demand-dependent stage appearances will need to be adjusted.

When making assumptions on demand dependency adjustments in a Proposed model, it should be considered what option represents the ‘worst-case’ scenario. This may depend on the level of impact that demand dependency has on network capacity, and sensitivity testing may be required to make an informed decision. If unsure, seek advice from the MAE to determine the best approach. After scheme assessment, when initial controller timings are produced in preparation for implementation, demand dependency adjustments should be removed to generate optimum offsets when demand-dependent stages appear. This is illustrated in **Figure 17** and described in more detail in **B2.5.6.3**.

⁵⁸ <http://www.jctconsultancy.co.uk/Software/LinSat/linsat.php>

2.5.2.4 Public Transport Adjustments

The Proposed models should incorporate any changes to public transport resulting from the proposals. This may include amendments to bus routes; changes in service frequency; relocation, removal or addition of bus stops and the introduction or removal of bus lanes.

Bus stop dwell times may also need to be revisited as part of Proposed modelling, where stops for different bus routes are combined or separated, or if additional passenger demand will be generated.

2.5.3 Sensitivity Testing

Sensitivity modelling can be undertaken where necessary to assess the robustness of a design, to allow for uncertainties in modelled assumptions. When required, sensitivity modelling is often undertaken prior to the detailed design stage and can involve assessment of various demand scenarios to determine, for example, how a scheme is likely to operate under varying demand conditions or which critical sites may become oversaturated with increased traffic demand. This may result in the scheme scope being revisited prior to detailed design.

Alternatively, sensitivity modelling can be used as part of the scheme refinement process to aid in the resolution of known issues and as part of contingency planning prior to a scheme being implemented on street, such as assessing various levels of calls for demand-dependent stages at a junction.

An example of how sensitivity testing can be carried out is detailed in the Transport Analysis Guidance (TAG) Supplementary Guidance document⁵⁹.

Sensitivity modelling is not a requirement for the standard scheme assessment process, and should only be included if it is deemed necessary at the MAP scoping meetings discussed in **B2.1.5.1**. The guidance within **B2.5** applies equally whether creating sensitivity modelling or the Proposed scenario.

59 <https://www.gov.uk/government/publications/tag-uncertainty-toolkit>

2.5.4 Construction Phases

The modelling of construction phases is not always required as part of the standard scheme assessment process. NIST would review the SIR described in **B2.6.5** and advise if the complexity of the scheme construction phases would require additional modelling to be undertaken. This may be determined by the length of time a construction phase is on-street or the perceived level of impact on the network resulting from a particular construction phase.

Construction phase modelling is normally undertaken by adjusting the Base / Future Base deterministic or microsimulation modelling to replicate the traffic management layout being assessed. Depending on the traffic management phase, in particular the length of time it is on street, a construction phase tactical model may also need to be produced. The requirements for construction phase modelling, such as which model and traffic flows should be used, will differ on a scheme by scheme basis and according to the individual traffic management phase arrangements. Therefore, precise requirements for construction modelling should be agreed with NIST and NPD.

MAP applies in all circumstances where traffic modelling is required for the purpose of assessing operational impacts of permanent or temporary changes on the TLRN or SRN. Therefore, MAP Stage 5 should be followed when building a construction phase model.

The guidance in **B2.5** applies equally whether creating construction phase modelling or the Proposed scenario.

2.5.5 Interaction Between Modelling Levels

The production of Proposed models often requires interaction between different modelling levels, as detailed in [B2.1.4.5](#). Clarification should be obtained in the Base and Proposal scoping meetings described in [B2.1.5.1](#) on which modelling levels are required for Proposed model development.

Traffic flows used in Proposed models following the Three Stage Modelling Process are determined as a result of interaction between the separate modelling levels. Demand matrices within tactical models are factored to reflect the predicted changes in demand for the assessment year. The factoring of demand flow is often influenced by TfL's Strategic HTA models which are described in section [B5.2.1](#). Following initial assignment of the tactical models, flows are transferred to deterministic models to produce optimised signal timings for the Proposed scenario. Following iterations of signal timings and flows between the two models to obtain a settled network, the final Proposed flows and routings are determined. The routings and flow change information from the tactical model can then be used to inform the Proposed microsimulation model. Throughout the process, additional mitigation and/or design adjustments may be necessary to reduce the impact of a proposal and to protect the wider network.

Traffic flows from different models may be aggregated over different time periods, therefore adjustments or factoring of tactical model flows may be necessary prior to use in other modelling software. Where peak hours differ between models, flows may require further adjustment to ensure they are comparable for the time periods modelled in the validated Base model. Careful consideration should be taken when deciding whether to use absolute or relative flow change values from tactical models, and both may need to be applied at different locations within the same model.

As microsimulation and tactical models do not have the ability to optimise signal timings, supporting deterministic models are often required. Signal timings may be further refined following detailed pedestrian modelling, where pedestrian stage minimums may need to increase to improve pedestrian comfort levels. For further information refer to Chapter [C3](#) on [Pedestrian Modelling](#).

Larger-scale projects could lead to significant traffic reassignment or modal shift, and therefore there may be a requirement to interact with TfL's strategic modelling suite to refine the Proposed demand.

2.5.6 Model Optimisation

As described in [A2.1](#), TfL has a legal responsibility to carry out its Network Management Duty, ensuring the expeditious movement of traffic across London. It is therefore necessary to coordinate the movement of traffic to enable efficient use of the network's geometric layout. This is achieved through implementation of appropriate traffic management strategies and optimising traffic signal timings to respond to varying traffic demands.

All signalised proposals should therefore undergo optimisation to ensure that the signal timings produced are the optimum timings for the demand scenario being modelled. This can be achieved through use of deterministic optimisation software, such as LinSig or TRANSYT, to generate Proposed signal timings. In congested conditions, microsimulation models can be used to further analyse and refine the signal timings produced by deterministic models.

Figure 17 demonstrates a generalised approach to optimisation, containing each of the three main phases of optimisation that may be required:

- **Phase One** – Initial Optimisation, used to enhance signal timings after the major design changes have been made within a proposal;
- **Phase Two** – Fine Tuning and Impact Assessment, used to hone signal timings and maximise performance within the proposal prior to impact assessment against the Base or Future Base models; and
- **Phase Three** – On-Street Controller Timings, an optional process based on model scope that is used to prepare initial signal timings for implementation on street.

If a decision is made to significantly alter the road network, signal timings, cycle times or other proposal details to improve the performance of the road network, consideration should be given to revisiting the tactical model to assess wider impacts of the revised changes. The Three Stage Modelling Process described in [B2.1.4](#) should be referred to when undertaking this task.

These optimisation phases are described in further detail below, to form a generalised framework within which judgement is needed to maximise the performance of a proposal according to the project scope.

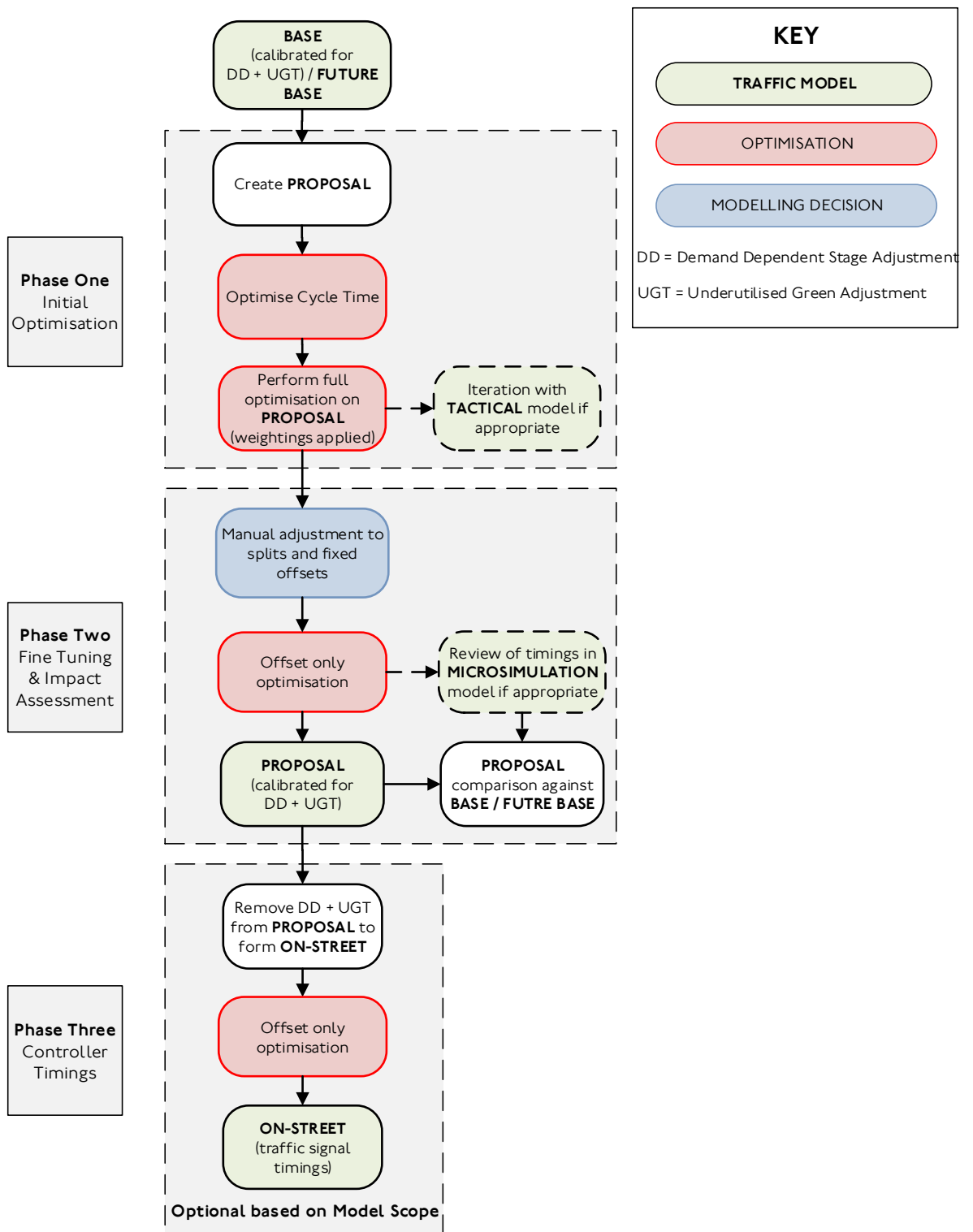

Figure 17: Overview of a proposed approach to traffic model optimisation

2.5.6.1 Initial Optimisation

The initial stage of optimisation provides an opportunity to assess the performance of a proposal after major design changes have been implemented, such as those outlined in **B2.5.2**. A flow chart detailing the initial optimisation phase is shown in **Figure 18**. The initial optimised signal settings are usually automatically generated through an optimisation algorithm such as those employed within deterministic models to reduce delay or increase capacity.

Major design decisions made during proposal development will broadly determine whether it is necessary to influence a software optimiser with weightings and penalties. These can be applied to encourage the optimiser algorithm to produce signal timings which reduce delay or limit queues in particular parts of the proposal, and can be used with care to achieve desired outcomes. For further detail on optimisation weightings, refer to the software-specific chapters within **Part B**.

During the initial stages of optimisation, it is essential to analyse the impact of signal optimisation by considering modelled queue lengths, platoon progression and overall network or junction performance. This should enable the model developer to assess whether the fundamental aspects of the design and signal strategy are likely to be acceptable. An optimised proposal should only move on to the fine-tuning stage once the basic performance of the model is considered appropriate. The remainder of this section highlights issues that may be influential in determining whether a model can progress to a more detailed signal strategy stage.

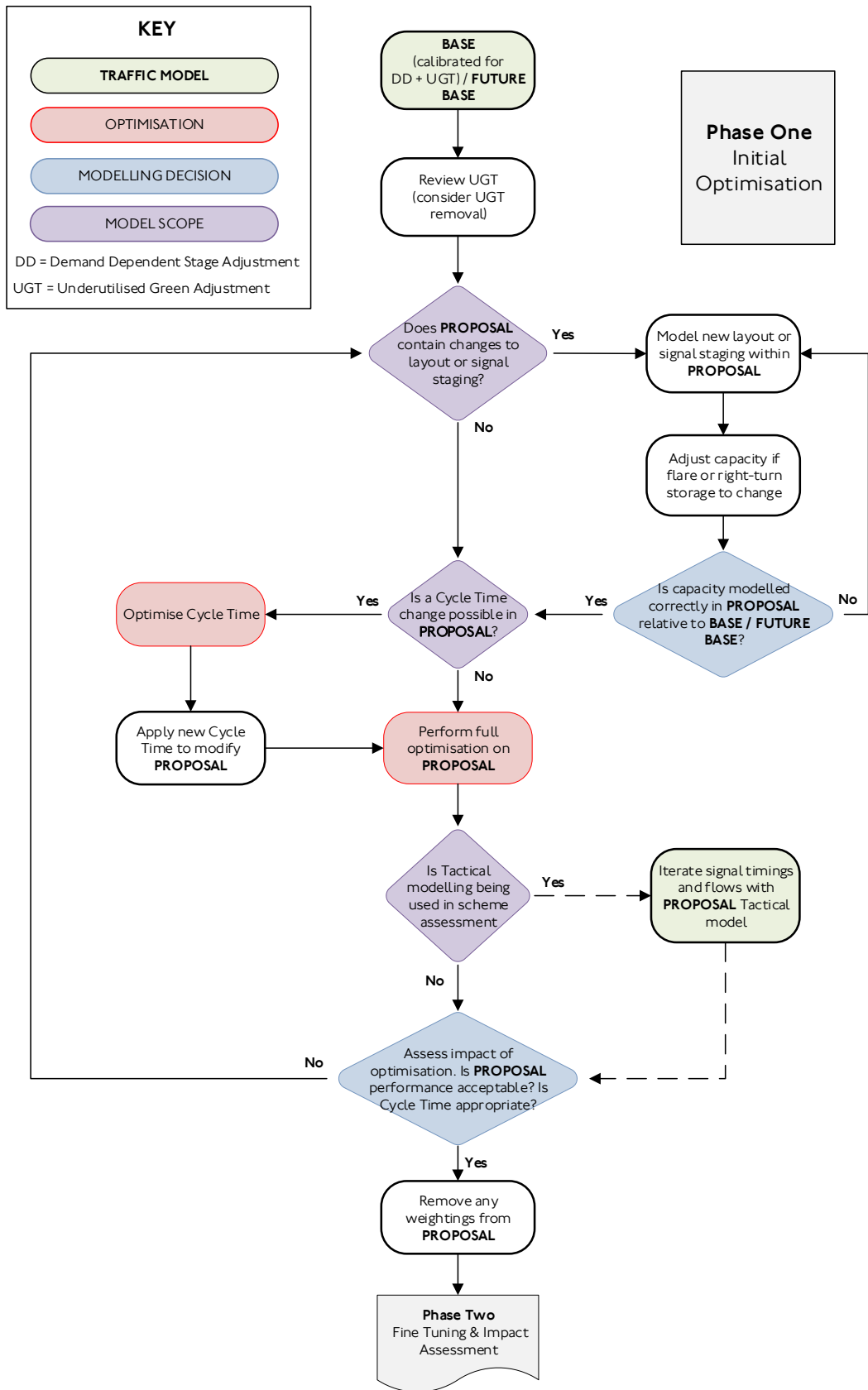

Figure 18: Initial optimisation approach

2.5.6.1.1 Underutilised Green Time

Underutilised Green Time (UGT) may be present in a validated Base model, representing lost time as a result of driver behaviour, localised junction characteristics or due to congestion, exit-blocking and the interaction with pedestrians or cyclists (section **B2.3.10.1**). Where UGT is modelled, it will have been based on site-gathered data and may be represented as negative phase lags, bonus greens or dummy stages.

UGT adjustments should only be modified if the cause of the original UGT present in the validated Base model is known and expected to change, for example if optimised splits or offsets are expected to reduce the onset of exit-blocking and congestion; interaction with other road users is expected to change or if physical layout changes are expected to influence the local characteristics and/or driver behaviour responsible for UGT. If unsure whether to amend Base UGT values, seek advice from the MAE to determine the best approach.

Where there is exit-blocking from outside the model boundary that is not expected to change, and cycle time amendments are proposed, it may be necessary to recalculate UGT values to match exiting flows with those observed in the validated Base model. This ensures no additional capacity will be modelled that is not expected to be realised.

If cyclist flows are predicted to change in the Proposed model, then consideration should be given to the influence this may have on UGT values. For further information on cyclist UGT treatment refer to **C2.5.2**.

UGT adjustment should be reviewed prior to initial full optimisation, and it may only be appropriate to reapply UGT during assessment of proposal impacts during fine tuning, prior to a final offset optimisation. If a model that has been used for a proposal impact assessment is subsequently used to generate on-street controller signal timings, UGT adjustments should first be removed if the adjustments are not critical for offset calculations.

2.5.6.1.2 Junction Storage Effects

Storage in front of stoplines for opposed turners is sometimes modelled as 'bonus' green, in order to account for vehicles clearing during the intergreen period. Where storage bonuses have been modelled, they should not be removed from any optimisation steps unless physical layout or staging changes within a proposal prevent the storage in front of the stopline from being used.

2.5.6.1.3 Cycle Time Optimisation

Scheme designers should choose an optimum cycle time that balances road traffic demand with pedestrian delay. If a change to cycle time is under consideration then it is important to understand its impact upon delay to pedestrians, linking to other signals and the overarching objectives outlined in the Mayor's Transport Strategy⁶⁰.

Where a cycle time change is anticipated at one or more junctions for a proposed scheme, the modelled cycle time should also be adjusted for any other junctions in the UTC control group. Only SCOOT-compatible cycle times⁶¹ should be considered, even in UTC Fixed Time and non-UTC areas.

Cycle times should be kept as low as reasonably practicable to minimise pedestrian delay, and ideally pedestrian waiting times should not exceed 82 seconds. This is due to pedestrian behaviour, as the higher the cycle time the greater the probability of pedestrians becoming impatient and crossing during a red pedestrian signal, potentially risking their safety⁶². The lowest UTC-compatible cycle time is 32 seconds, however SCOOT nodes require an additional 4 seconds over and above the summation of SCOOT stage minimums, meaning cycle times of lower than 64 seconds prohibit SCOOT double-cycling.

Ideally standalone pedestrian crossing facilities should be set to double-cycle where the cycle time allows. The possibility of increasing a junction's cycle time can therefore be investigated to produce pedestrian benefits at other sites within the group. An increase in cycle time can facilitate double-cycling, asymmetrical double greening or allow the provision of an extra stage that could directly benefit pedestrians. Conversely, a proposed cycle time increase at one junction to accommodate a proposed pedestrian facility should not have a detrimental effect on other pedestrian facilities within the operational group. This may create additional delay and result in an overall net disbenefit for pedestrians.

60 Mayor of London, Mayor's Transport Strategy, March 2018

61 Allowable SCOOT-compatible cycle times, in seconds, are: 32, 36, 40, 44, 48, 52, 56, 60, 64, 72, 80, 88, 96, 104, 112, 120, 128 and on some occasions 144

62 <https://content.tfl.gov.uk/factors-influencing-pedestrian-safety-literature-review.pdf>

2.5.6.1.4 Junction Performance

It is necessary to be aware of the relationship between traffic delay and DoS in order to best optimise junction performance during proposal development. The relationship illustrated in **Figure 19** highlights that a network is generally stable below 85% DoS, however delay begins to increase exponentially above this level and can lead to unstable network performance. At junctions operating close to zero Practical Reserve Capacity (PRC), corresponding to approximately 90% DoS, small reductions in capacity can result in a significant increase in delay. For this reason, a DoS of 90% represents an upper limit of practical capacity for signalised junctions, however greater reserve capacity is necessary on strategic routes to help maintain acceptable performance, allowing for flow variation and other random events. Unsignalised junctions typically have a lower practical capacity limit than for signalised junctions, with an upper stable saturation limit in the range 80-85%. Junction capacity relationships are important to consider when designing schemes to ensure that new proposals perform well within the existing network.

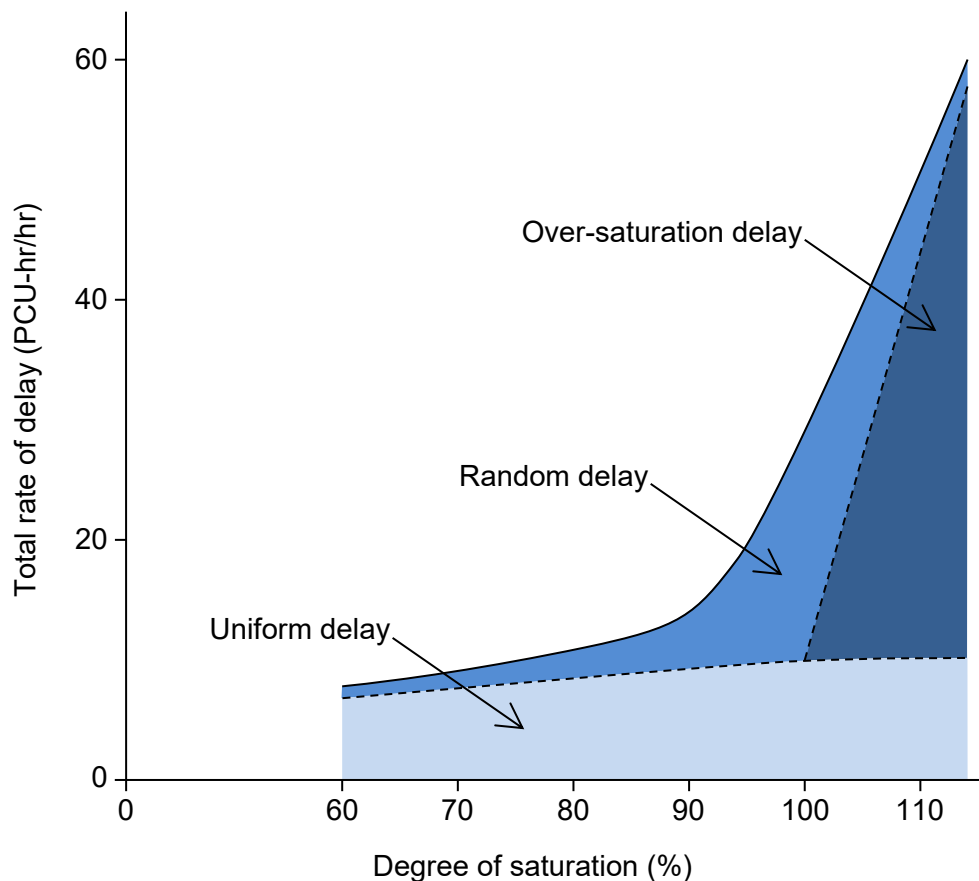

Figure 19: Relationship between junction delay and degree of saturation

2.5.6.1.5 Iteration with Tactical Models

When assessing a scheme using the Three Stage Modelling Process covered in **B2.1.4**, there is a need to iterate signal timings produced by deterministic models and flows produced from tactical models. Deterministic models with the Future Base or Proposed scenario coded should first be optimised with the existing Base or Future Base traffic flows, with relevant adjustments as applicable to the design. The updated timings can then be fed into the tactical model to allow for flow reassignment. The flows from the reassigned tactical model can then be applied into the deterministic model for further optimisation. This iteration process between the tactical and deterministic models continues until traffic reassignment settles.

When generating signal timings during this iterative process, it is important to ensure that signal timings adhere to any on-street constraints or traffic management strategies. NPD should be consulted for advice on any signal timing constraints.

2.5.6.2 Optimisation Fine Tuning and Impact Assessment

The fine-tuning stage of optimisation allows for the manual adjustment of the initial settings automatically generated by a software algorithm. These adjustments provide an opportunity to maximise the performance of the proposed design and minimise wider network impacts. The major design decisions have been completed and acknowledged as fit for purpose, so this stage of the process evaluates how minor modifications to the proposal can improve network performance relative to the Base or Future Base models. A flow chart detailing the optimisation fine tuning phase is shown in **Figure 20**. The following subsections outline a few approaches to fine tuning that can be employed to generate an operable signal strategy.

2.5.6.2.1 Balancing the Network

If model outputs indicate queue storage problems after initial optimisation, it should be considered whether a more balanced loading of the network can be achieved. The available network capacity can be manually adjusted during fine tuning (such as through changes to green splits), with the model then undergoing offset-only optimisation to ensure good platoon progression but with a fixed network capacity.

Fixed relationship junction groups should not be changed from a validated Base model without prior consultation with NPD as these permanent offsets may need to be maintained in the proposed scenario.

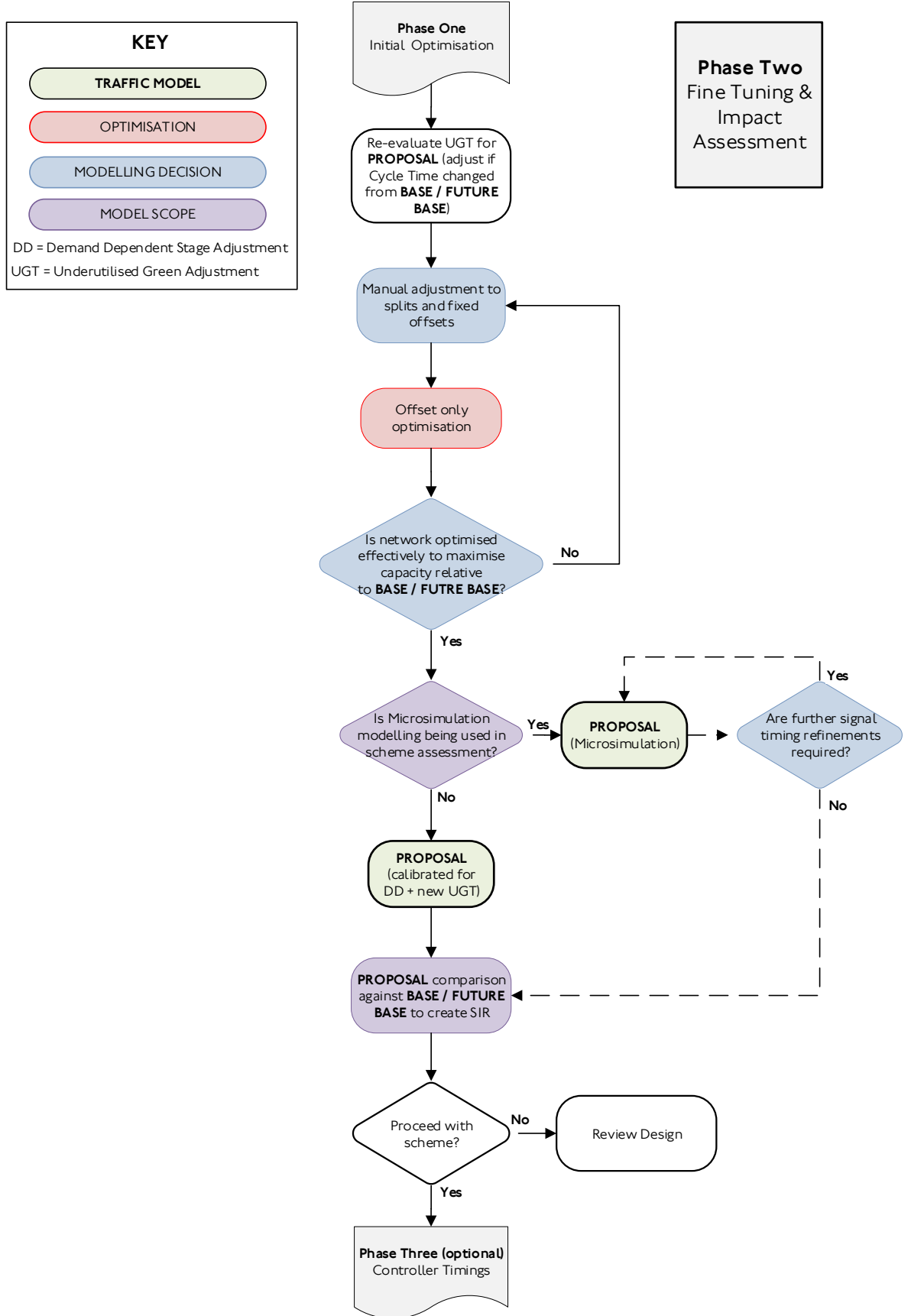

Figure 20: Optimisation fine tuning and impact assessment approach

2.5.6.2.2 Utilisation of Network Capacity

It may be more efficient for a proposal to contain fixed signal offsets to prevent cyclical problems caused by fanning, funnelling or exit-blocking. Within certain network layouts the use of a fixed offset can encourage drivers to fully utilise available capacity.

Underutilisation of upstream lanes can result from traffic funnelling over a short distance, such as a reduction of lanes for general traffic on the exit to a junction. The potential impact of traffic funnelling should be reflected in the upstream lane structure of the model through the introduction of flares or by reducing the saturation flow assumption. Conversely, fanning into a wider carriageway may prevent downstream links from fully contributing towards stopline capacity. Where this is the case, fixed offsets should be manually applied to ensure full lane saturation by only allowing platoon progression once all lane storage has been utilised. Fanning may prevent downstream lanes from contributing to capacity where it is not possible to fix the offset, and in this case reduced upstream saturation flows should be applied to the downstream lanes. However, this would only be necessary where downstream lanes are grouped together, and not if individual lanes are modelled.

Once the internal links operate satisfactorily, manual optimisation can be performed. Cyclic flow profiles can be audited to ensure appropriate front and back end platoon coordination exists between closely associated links. This analysis should confirm whether the proposed traffic control strategy of fixed groupings is being implemented properly and provides an opportunity to further fine tune offsets and promote efficient lane utilisation and platoon compression.

2.5.6.2.3 Protecting the Network

Where a proposed network is operating close to its limit of practical capacity it may be necessary to protect the network from unexpected traffic fluctuations. This risk can be mitigated by manually adjusting green times to saturate any under-saturated external (entry) links. This strategy can be used to prevent internal links becoming overwhelmed with traffic that cannot be stored within the network. Over-saturated internal links can lead to high levels of unpredictable delay and poor journey time reliability within a proposal.

2.5.6.2.4 Interaction with Microsimulation Modelling

Where the project scope allows, the operation of optimised signal timings should be reviewed using microsimulation software. This allows for the timings to be assessed in relation to on-street traffic behaviours and interactions. This assessment is especially useful in congested traffic conditions and where specific traffic behaviours arise, such as merging.

2.5.6.2.5 Improving the Design

When the models have been correctly produced and the results show increased delay to one or more modes, the proposed design should be revisited to mitigate this where possible, in line with the scheme objectives. The local area team within NPD should be consulted prior to amending any designs to ensure any proposed changes can be implemented on street.

2.5.6.3 On-Street Implementation

If the scheme is approved by TfL, the final stage of the optimisation process is the production of initial controller signal timings that will be refined prior to on-street implementation. A flow chart detailing the on-street implementation phase is shown in [Figure 21](#).

The first step in this process is the removal of any signal timing adjustments to take account of demand dependency and UGT, unless the adjustments are critical for offset calculation. Once the demand dependency and UGT adjustments have been reviewed, a check should be undertaken to ensure that all signal phases are present and receiving their minimum green time. This may require manual adjustment of the stage lengths generated at the end of the Fine Tuning and Impact Assessment stage to ensure all phases are present. The manually adjusted stage lengths should then have offset-only optimisation performed.

Following optimisation, the signal timings should be carefully checked to ensure they are appropriate and further manual adjustments may be needed to stage lengths and offsets before timings can be tested on street. Once the signal timings are implemented on street it is critical that observations are undertaken during all peak periods to ensure that the timings are operating correctly. At this stage there may be further refinements to signal operation, including the implementation of signal strategies such as SASS and Bus Priority. Refer to [B2.3.8.3](#) for further details on these.

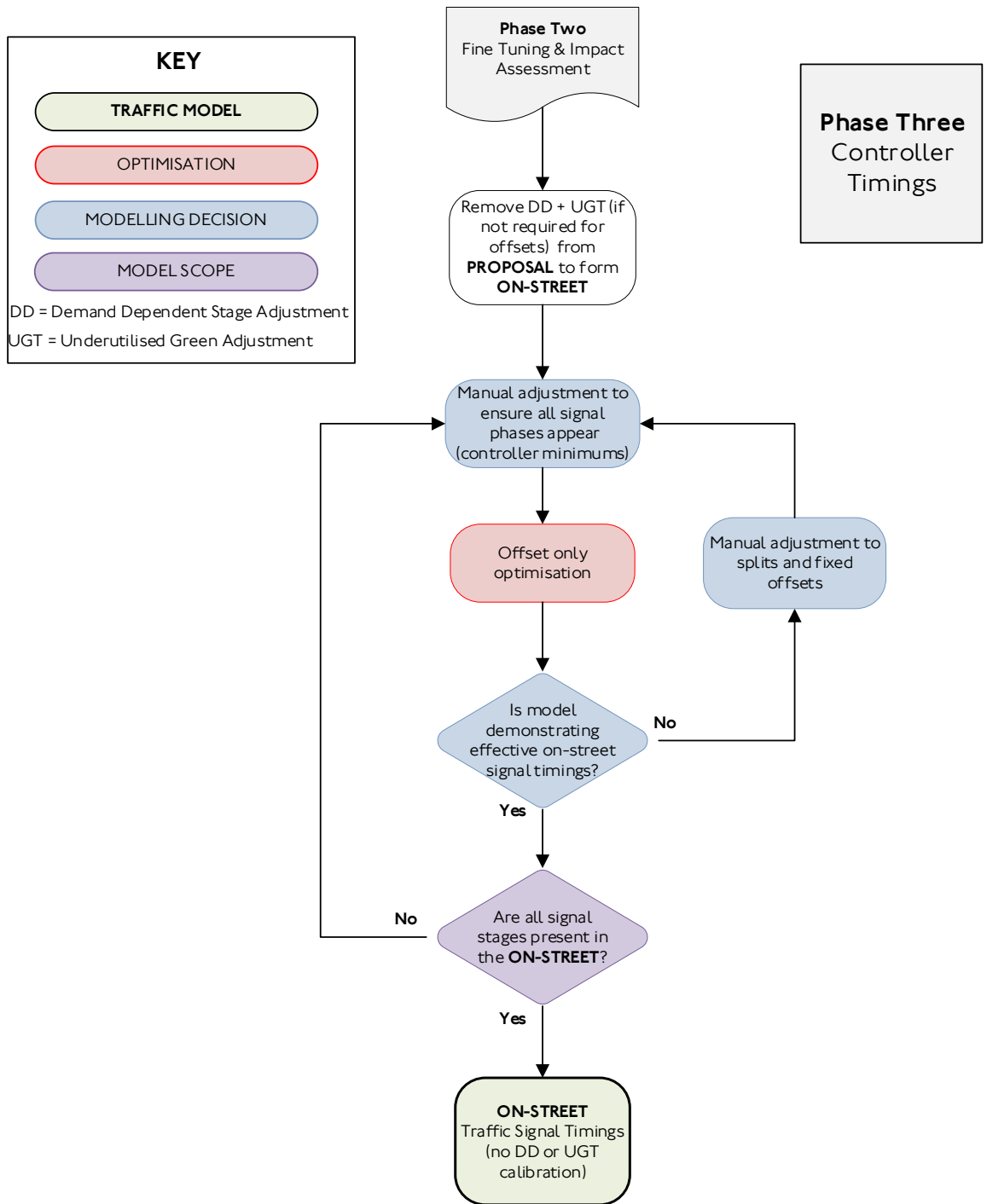

Figure 21: Derivation of on-street controller timings

2.5.7 Model Assessment

Models can generate a wide range of outputs that provide an indication of the performance of the network. Performance statistics that could be provided include:

- Degrees of saturation (DoS);
- Link / lane capacities (PCU/hr);
- Junction practical reserve capacity;
- Maximum average queue lengths;
- Cyclic flow profiles (CFPs) for critical links (short / highly saturated);
- Percentage green per junction wasted due to exit-blocking;
- Percentage of buses per route waiting more than one cycle to clear nodes;
- General traffic journey times;
- Cyclist journey times;
- Delays;
- Excess Wait Times;
- Emissions;
- Mean travel time and standard deviation for private and public transport along pre-defined routes; and
- Mean pedestrian travel time along pre-defined routes.

There may be occasions when it will be necessary to present the impact of a proposed scheme using a selection of these performance indicators, depending on the objectives of the scheme. Where this is the case these should be discussed at the Base and Proposal Scoping Meetings described in **B2.1.5.1**. The selection of performance indicators should be agreed in advance with NPD and other key stakeholders, such as NIST and the London boroughs.

2.6 Model Reporting

Reporting should reflect the logical approach taken to resolve the complex and iterative nature of traffic model development, and should emphasise the sound engineering principles adopted. Without accurate reporting, the process of model development is hindered by a lack of historical information to understand the decisions taken. The following subsections outline an approach to model reporting that should allow a third party to accurately comprehend the decisions made during the development process, from network familiarisation through to proposal evaluation.

A traffic model may be developed over a period of months or even years by a number of different parties. While developing a model, detailed notes should be retained that include a record of all assumptions and modelling decisions. These notes should be kept for future reference and can form the basis for subsequent reporting.

It is the responsibility of the Promoter and their modelling representatives to ensure that all reporting is accurate, thorough, sufficient, and that submitted documents are fit for purpose to adequately support accompanying models.

All modelling reports should be accompanied by electronic copies of all modelling files for that stage of the scheme assessment. The model files should have version control in place so that a full audit trail can be followed.

2.6.1 Calibration Report

A calibration report should present all relevant survey data and include a history of model development.

Model auditing will rely on the report to explain how the model has been calibrated. For this reason, the calibration report should focus on presenting traffic model inputs and detailing how the model has been developed to ensure that it represents existing conditions. In particular, the following should be included:

- The stated purpose of the model;
- A list of all TfL-referenced sites in the model, with addresses and, where required, a note detailing any operational relationships (such as UTC multinodes and subgroups);
- Clear notes on site observations and measurements, covering both the physical network and observed vehicle behaviour. Where

behaviour is specific to a particular time of day this should be noted, along with how it has been accounted for in the model;

- Site data highlighting measured saturation flows, cruise times and effective flare lengths;
- Table of saturation flows for each link in the network, indicating whether values have been measured on site or calculated. If calculated (for example using RR67) a justification describing why measurement was not possible; and
- Description detailing the extraction method used to obtain signal timings, including the source of data (such as fixed time UTC plans, CLF timings, or average timings representing SCOOT operation).

Specific calibration reporting requirements for deterministic and microsimulation modelling are detailed in MAP Stage 2, as described in **B2.1.5**. The reports submitted should be broken down into the relevant MAP sections to help the auditor conduct the review quickly and efficiently.

2.6.2 Validation Report

Validation reports should look in detail at comparisons between calibrated model results and existing conditions. The report should detail the validation process, from on-site surveys through to adjustments made within the model. Any decisions made by the model developer should be captured, especially where model inputs have been adjusted in order to achieve validation.

Validated model results should be tabulated and compared with the surveyed on-street values for all modelled periods. If there are discrepancies between the model outputs and the on-street conditions then these should be identified, investigated and explained. Specific items that could be included in the validation report are:

- Details of traffic flows used, when they were recorded, who recorded them and how the modelled peak periods were chosen;
- Demand dependency calculations, including source data and how demand dependency has been accounted for in the model;
- Validation data, such as vehicle journey times, DoS and UGT;
- Relevant site observations not already included in the calibration report, such as give-way behaviour, exit-blocking, flare / non-green usage, parking / loading and bottleneck details; and

- Evidence of validation, comparing modelled results to on-street observations and measurements. Any discrepancies should be analysed and discussed.

Specific validation reporting requirements for deterministic and microsimulation modelling are detailed in MAP Stage 3, as described in **B2.1.5**. The reports submitted should be broken down into the relevant MAP sections to help the auditor conduct the review quickly and efficiently.

2.6.3 Future Base Report

A Future Base report should accompany Future Base models, which should state the year of the model, identify any proposed schemes included within the tactical model and any modifications made to the validated Base microsimulation and deterministic models.

Future Base model results should be compared to the validated Base model for all modelled periods. Any significant changes from the Base model results should be investigated and explained. Specific items that could be included in the Future Base report are:

- Details of the methodology used for the interaction between different modelling levels, including a record of any adjustments made to the flows and routing information provided from tactical modelling to match assumptions made in the Base modelling;
- A list of all proposed schemes included in the Future Base assessment, including any modifications required in the deterministic and microsimulation model boundaries;
- Any proposed changes to bus routes, bus frequencies and bus stop dwell times;
- Details of any demand dependency and UGT assumptions;
- Any mitigation strategies applied to the model associated with any proposed schemes;
- Details of the methodology used for determining the Future Base cycle demand and routing; and
- A summary comparing model results to those in the validated Base model (described further in **B2.6.7**).

The journey time routes validated in the Base microsimulation models for general traffic and buses should be collected in the Future Base model and a comparison made.

Specific proposal reporting requirements for deterministic and microsimulation modelling are detailed in MAP Stage 5, as described in **B2.1.5**. The reports submitted should be broken down into the relevant MAP sections to enable the auditor to conduct a review quickly and efficiently.

2.6.4 Proposed Model Report

The report accompanying a Proposed model should give a full description of the proposed scheme and objectives, with any expected scheme impacts and changes in demand. The modifications made to the validated Base or Future Base model to develop the Proposed model should all be based on these key details. All changes made in order to develop the Proposed model should be documented, along with the reasoning behind them. Specific items that could be included in the Proposed model report are:

- Scheme summary;
- Scheme objectives;
- Proposed traffic management strategy;
- Evaluation of proposal results;
- Conclusions and recommendations;
- Design summary sheets;
- Model source data; and
- Modelling assumptions, including interaction between modelling levels, influence of other proposed schemes, public transport amendments and cyclist flows.

Results of the Proposed model should be compared to the validated Base model and Future Base model. This should be done for all modelled periods to demonstrate the expected impact of the proposals on the network (described further in **B2.6.7**). The Proposed model report should include a discussion and interpretation of model results. It is useful to include a section detailing the impact of any geometric changes as this enables NPD to make informed comments about preferred design options. Version control should be applied to all design documents to avoid ambiguity, thus ensuring all parties are aware of the current design status for each Proposed model.

Results from the approved Base and Future Base models should be presented alongside the Proposed modelling results. NPD will use

modelling outputs and analysis to assess the likely impacts of the scheme. The Base, Future Base (if applicable) and Proposed model submissions will be considered when producing the SIR, therefore it is in the scheme Promoter's interest to ensure Proposed model submissions are provided with detailed analysis.

Specific proposal reporting requirements for deterministic and microsimulation modelling are detailed in MAP Stage 5, as described in **B2.1.5**. The reports submitted should be broken down into the relevant MAP sections to enable the auditor to conduct a review quickly and efficiently.

2.6.5 Scheme Impact Report

As part of the scheme approval process, a Scheme Impact Report (SIR) must be produced and submitted to the Network Impact Specialist Team (NIST). The SIR contains safety information, including the buildability and future maintenance of the scheme, together with information on the integrity of the modelling and the potential impact on the network, broken down by mode. The report is completed by the scheme Promoter, Engineering Services and a representative from NPD.

The SIR should be attached to the respective Scheme Traffic Management Act Notification (TMAN) by the respective scheme Promoter. The SIR helps to clarify the operational impact of the permanent scheme changes and helps to demonstrate how, in the case of a TfL-promoted scheme, TfL is complying with its Network Management Duty (NMD) under the Traffic Management Act 2004 (TMA). TfL's Traffic Manager has a statutory responsibility in this regard, as explained in **A2.1**. In the case of a scheme promoted by a London borough council, which is on or affecting the SRN or TLRN, TfL has oversight of the borough's NMD and will require a Scheme TMAN from the respective borough in this regard. Depending on the nature of the scheme proposal, an SIR and associated modelling may be required as part of this submission to help demonstrate impacts and associated mitigation.

NIST look to ensure appropriate operational balance on London's TLRN and SRN following introduction of a permanent scheme, and also during the construction phase of scheme delivery in line with TfL's statutory obligations. The process involves reviewing a range of operational information to help reach conclusions in this regard. As a result, there may be a need to undertake some modelling work in relation to the construction phases of a project; especially where long term, and/or complex changes to the network are required in advance of the final scheme arrangement being delivered.

2.6.6 Public Consultation

Modelling outputs play a key part in the information presented during Public Consultations, and can give the public an accessible indication of the scheme impacts. Base or Future Base model journey time outputs from microsimulation models are compared against those in the Proposed models. The modes evaluated within the Public Consultation document are as follows:

- **Traffic** – Average journey times (minutes);
- **Buses** – Average journey times on all bus routes through the scheme area (minutes); and
- **Cyclists** – Average journey times (minutes).

The journey times presented are the key routes within the model boundary and, if possible, are validated within the Base model. If there are bus services that take a similar route, they would be amalgamated to show an averaged journey time for these bus services.

Public consultations often detail the total average wait time for pedestrians. This information is extracted from dynamic pedestrian modelling assessments, using LEGION or Viswalk, or static spreadsheet analysis. Refer to Chapter **C3** on **Pedestrian Modelling**, for further information on pedestrian modelling assessments.

Supporting information for public consultations can be provided from tactical and deterministic model outputs. Plots from tactical models can show where traffic flow reassignment is predicted surrounding the scheme, and stopline saturation and signal timings can be provided from deterministic models.

For particularly high-profile schemes, it may also be advisable to include 3D visualisations of the scheme. This is particularly useful to help the public understand the interaction between general traffic, buses, cyclists and pedestrians and to demonstrate any benefits to vulnerable road users.

2.6.7 Presentation of Modelling Outputs

Since modelling is only able to provide a prediction of outcomes resulting from the implementation of a scheme, it would be inappropriate to report on precise results in a granular level of detail, for example journey time differences to the nearest second. It is common for model results to be misinterpreted by a non-technical audience, therefore, it is common for the results of tactical modelling and microsimulation modelling (both traffic and pedestrian) to be banded. For tactical modelling, plots indicating where traffic flows changes are predicted are grouped into bands often of

50 to 100 vehicles per band. Journey time outputs produced by microsimulation models are similarly often banded. **Table 6** shows an example of journey time bands used, where ranges of 1 minute, 2 minutes or 5 minutes are given.

Table 6: An example of reporting time ranges

Base / Future Base Results (mins)	Range used (mins)
1 to 10	1
10 to 20	2
20+	5

For example, if the Future Base journey time was 5 minutes 35 seconds and the Do Something journey time was 16 minutes and 40 seconds, the journey times would be reported as 5 – 6 minutes in the Future Base and 16 – 18 minutes in the Do Something model with a difference of 10 – 12 minutes. Conversely, if a Future Base model had a journey time of 10 minutes and 30 seconds and the Do Something model journey time was 7 minutes 15 seconds, the journey times would be reported as 10 – 12 minutes in the Future Base model and 7 – 8 minutes in the Do Something model with a difference of minus 3 – 4 minutes.

The bandings used to group model outputs are scheme-specific and should be agreed with NPD.

2.6.8 3D Modelling

The traffic modelling outputs produced during the Three Stage Modelling Process can be technical in nature and require a modelling professional to understand and interpret what the outputs represent. The ability to convey modelling analysis through a medium which non-modelling professionals can understand is crucial to ensuring engagement with wider stakeholder audiences. It can also help with comprehension of the benefits a proposed scheme will bring to a local area.

A method to effectively display modelling outputs in an accessible form is to utilise 3D modelling and animation software. This involves recreating the modelled environment and creating a 3D digital representation of the proposals and analysis. To create a 3D representation the following steps are undertaken:

- Converting traffic model vehicle simulations into realistic 3D representations of vehicles, to simulate vehicle movement and behaviour;
- Replicating the highway proposals into a 3D format and assigning materials to represent the various hardstanding surfaces; and
- Generating buildings and landscaping features to give context to the surrounding area.



Figure 22: An example of a static computer-generated image produced for a public consultation

3D modelling software can output static images as shown in **Figure 22**, or render an image sequence to create a video file as illustrated in **Figure 23**. Using postproduction techniques, a voiceover, subtitles and descriptive text can be overlaid on the 3D outputs to help deliver a narrative behind the analysis and to help the audience fully understand and engage with the modelling analysis.

Using a video output with a clear narrative is a proven method to ensure that any audience can engage with modelling analysis, and helps to achieve necessary agreement when trying to implement a scheme, for example during Public Consultations.

There are several forms of 3D outputs that can be produced, including 360° video, Augmented Reality and Virtual Reality, which can be used in different ways to achieve greater audience engagement. It is recommended

to consider how these outputs can be produced and utilised, and to identify the benefits of each. This can provide a robust toolset to draw upon when creating outputs for various stakeholder groups.



Figure 23: An example of an animation video produced using outputs from a Vissim model, with the existing image shown above and the scheme image shown below

3 Aimsun Next Modelling



3.1 Introduction

This chapter is designed to provide guidance for experienced practitioners when building microsimulation models of London's road network using Aimsun Next. It augments the general modelling guidance given in Chapter **B2** on **Modelling Principles**.

This chapter outlines TfL's recommended approach for microsimulation modelling with Aimsun Next. However, there will be cases where local conditions or project requirements dictate the use of methods which may be different to those outlined. In these situations, NP should be consulted on the planned methodology where modelling will be submitted for approval by TfL.

3.1.1 Introduction to Aimsun Next

Aimsun Next is transport modelling software made by Aimsun, which is a subsidiary of Siemens Mobility. It is a fully integrated application which includes microsimulation, mesoscopic simulation, macroscopic and travel demand modelling. It also has the capability to combine these in two hybrid simulators: micro-meso and macro-meso. These Guidelines only consider the microsimulation aspect of Aimsun Next.

Aimsun Next microsimulation uses a Lane-Based network layout and a car-following model to accurately reflect the way vehicles move through

junctions and roads and interact with each other. The latest version includes integrated pedestrians and has started to include a lateral behaviour model for cyclists. Signals can be modelled using either internal fixed-time control plans or through the API, which essentially means that any signal control system can be used as long as an interface has been coded. At the time of publishing there is no simulated version of UTC that works with Aimsun Next, however future versions of UTC will have Aimsun Next integration.

Aimsun Next can be used to model complex and congested traffic networks, where deterministic modelling cannot provide a realistic representation. In common with other microsimulation software, it is unable to optimise signal timings, and so is usually used in conjunction with deterministic modelling when looking at proposed schemes.

Further information can be found on the Aimsun website⁶³.

3.1.2 Software Versions

The current version of Aimsun Next is Aimsun Next 20. This release “focuses on modelling pedestrians, bicycles and the interaction between passengers and public transport vehicles”⁶³. The TfL Aimsun Next Template contains standard modelling parameters to be used when commencing a modelling project in Aimsun Next for TfL⁶⁴.

Whichever version of Aimsun Next is chosen for a modelling project must not be changed throughout the project, and particularly not after the Base model has been validated. Running the same model in a different version of the software will invalidate the results.

3.1.3 Appropriate Use of Aimsun Next

Since this guidance relates to the microsimulation aspect of Aimsun Next, only this type of modelling is considered. As a microsimulation model, some examples of where it is appropriate to develop Aimsun Next models include:

- Where over-saturated conditions exist, and particularly where exit-blocking occurs, or where queues interact with other facilities;
- Where network infrastructure changes dynamically throughout the modelled period (for example VA, demand dependency, bus priority at signals), however, at the time of publishing, there is no interface between Aimsun Next and an offline version of the UTC system, so exact UTC behaviour cannot be replicated;

⁶³ <https://www.aimsun.com/aimsun-next/>

⁶⁴ The latest TfL Aimsun Next Template is available on request from NP

- Where accurate journey time prediction is important as an improvement measure (such as in a bus priority scheme); and
- Where it is necessary to visually demonstrate the operation of a scheme, traffic management technique or control strategy for use in a stakeholder consultation or Public Inquiry.

Aimsun Next should be used appropriately to complement analyses provided by traditional traffic signal optimisation and design tools such as LinSig and TRANSYT.

3.2 Preparation

General guidance on Base model development is provided in section **B2.4**. This section provides specific guidance for building Base models using Aimsun Next. Model preparation should be discussed at the scoping meeting (section **B2.1.5.1**) and decisions documented within the Modelling Expectations Document (MED, section **B2.1.5.2**).

3.2.1 Model Boundary

Aimsun Next is able to model adjacent CLF or UTC groups operating different cycle times. It can therefore assess the impact of scheme proposals which cover two or more traffic control groups. Where blocking back from one group impacts traffic upstream, Aimsun Next can be used to predict the magnitude and frequency of any operational issues and test proposals for mitigation. For this reason, where possible, junctions which generate significant queuing in the area of interest should be included in the modelled area. If it is not possible, for example if the cause of queuing would significantly increase the size or complexity of the model, then a proxy must be used.

When deciding on the Aimsun Next model boundary the length of external sections (such as those where vehicles are loaded onto the network) should be considered.

An external section ought to be long enough to contain all traffic expected to enter within the modelled time period, in all scenarios.

There are two reasons this should be done:

- To ensure that any upstream blocking back effects can be easily identified (visually) and mitigated; and
- To ensure that when measuring scheme performance parameters (for example journey time, delay, queue length, average speed) all vehicles are included. If some vehicles are not successfully loaded into the network, the model will produce a biased result which may underestimate the capacity impacts of the scheme.

If the Sections are not long enough then vehicles will queue outside of the modelled area waiting for a space to enter. All Sections should be extended to capture the extent of the queuing.

3.2.2 Data Collection

Prior to building a model in Aimsun Next the following information should already have been obtained, as identified in sections **B2.2** and **B2.3**:

- Network layout (section **B3.2.4**);
- Familiarity with site operation and driver behaviour;
- Traffic flows and turning proportions;
- Traffic flow compositions (according to vehicle classifications);
- Bus frequencies;
- Bus stop locations;
- Bus stop dwell times;
- Signal timings and controller logic;
- Saturation flows;
- Vehicle journey times;
- Queue lengths;
- Mandatory speed limits; and
- Parking and loading.

The following data may also be needed, depending on the purpose of the model:

- Origin-destination (OD) surveys;
- Speed and acceleration profiles;
- Bus boarding and alighting surveys;
- Pedestrian flows; and
- Bus occupancy surveys.

In addition to collecting the above data, skeleton local models should be produced for all junctions to be modelled in Aimsun Next, as detailed in section **B4.1.3.2**. This will ensure signal timings are accurately represented, particularly when modelling stage and interstage relationships.

The remainder of this introductory section provides specific guidance on the collection of some of the above data as necessary for the preparation of Aimsun Next models.

3.2.2.1 Site Observation

Microsimulation models are able to simulate complex interactions between road users and their environment. It is therefore essential that observations are undertaken at sites being modelled so that interactions can be noted and replicated in the model. It is not sufficient to use drawings and aerial photography only to build a model, as these are static

sources and may not convey all the dynamic aspects of the site. CCTV may also be used; however, this is not an ideal solution as not all areas are covered and it is easy to pay less attention to areas which cannot be seen. Preferably, CCTV would be used in addition to, rather than instead of, site visits.

Examples of behaviours which should be observed are:

- **Space utilisation** – particularly where usage does not match lane markings;
- **Blocking back** – through junctions, across crossings, yellow boxes and keep clears, anywhere another traffic movement is prevented from continuing on its desired path;
- **Lane changing** – particularly the decision point where vehicles decide to change lanes for turns;
- **Parking** – both legal and illegal if it is persistent and takes space away from moving traffic;
- **Queuing** – locations, lengths, and behaviour; and
- **Gap acceptance** – at give-ways or opposed right turns.

These can significantly affect model results and must be understood from site visits in order that they can be accurately replicated in the model.

It is also important, whenever possible, to carry out site observations on days when traffic surveys, for example counts or journey times, are taking place. It is important to verify that the data collected represents a day that is considered typical or the data collection may need to be repeated at a later date.

3.2.2.2 Signal Timings

Guidance on how to collect and use signal timing data is provided in **B2.3.8**. The data requirements include phase, stage and intergreen data from Timing Sheets. For UTC junctions the control plan is also needed, along with the frequency of any demand-dependent stages. For VA or MOVA junctions green time surveys are used to determine the average frequency and duration of each stage.

If more complex forms of dynamic control, such as bus priority, have a significant impact on the behaviour of the junction, then information on this should be collected so that it can be replicated appropriately.

3.2.2.3 Saturation Flows

In most cases, an Aimsun Next model will be developed to complement an existing validated LinSig or TRANSYT model which already contains measured saturation flows, so saturation flows from those accompanying models should be used for calibration of the Aimsun Next model.

Guidance on saturation flow measurement is provided in **B2.3.9**. Where a validated LinSig or TRANSYT model is not available, it will be necessary to measure saturation flows for the purposes of calibrating the Aimsun Next model. These are some examples of situations where it is critical to measure saturation flows for an Aimsun Next model:

- Approach has extensive queues, for example a bottleneck;
- Approach is an entry into the Aimsun Next network;
- There are proposed changes to the layout; and
- There are proposed changes to the method of control or intergreens.

This is not an exhaustive list and it remains necessary to exercise good judgement when assessing situations where it is critical to measure saturation flow.

3.2.2.4 Journey Times

It is necessary to have journey time data to validate an Aimsun Next Base model. In recent years, sources of GPS tracked vehicle data have become available which give a much wider range of possibilities when it comes to choosing dates, times and distances. In particular, it is possible to get an average journey time over multiple days, which provides a more robust value to validate against.

Where it is not possible to source GPS data, journey times should be collected at the same time as the other traffic surveys if possible, however for larger networks it may be necessary to conduct the journey time surveys over several days. Journey times in Aimsun Next can be collected and measured over any number of sections, via either Groupings or Subpaths (section **B3.7.2.3**), making it adaptable to available site-measured journey time data. It is recommended that journey time data is collected over smaller distances, in addition to the full routes, as this will help with locating any disparities during validation.

3.2.2.5 Public Transport

Bus data in London is recorded using the iBus system, which collects data on frequencies, journey times and dwell times for each bus. This data can be requested from TfL but any requests must go through a TfL sponsor to ensure the request is valid and formatted correctly.

Information on the running of coach lines should be sourced from the relevant company's website.

3.2.3 Model Time Periods

The model time period should be specified to match the requirements of the analysis to be undertaken and based on the flow data which has been collected. The model must start with a warm-up period that sets the initial conditions in the network and provides the model with costs for the route choice calculation. A cool-down period may also be included if there is the possibility that the proposal could extend the peak hour(s). General guidance on model time periods is given in **B2.3.3**. It should be noted that many of the objects that make up a Scenario, for example the Traffic Demands, signal Control Plans and Public Transport Plans, have their own initial times and durations and these all need to be configured correctly for the model to function properly.

Aimsun Next is not constrained to modelling a single peak hour period. For a broader assessment it is possible to create models which cover three or more hours, which is beneficial for an assessment of traffic during the shoulders of a peak period or where models are sufficiently large that different areas of the model experience localised peaks at different times.

As mentioned above, Aimsun Next models must include a warm-up period in addition to the analysis period. The length of the warm-up period will depend on the network size and congestion level. It is recommended that the warm-up is long enough that the flows within the model are stable and all vehicles can finish their journey. This length of time can be calculated by applying a flat matrix and running the simulation without a warm-up, with a one-minute statistics interval. The time series will show when the number of vehicles within the model is stabilised. This time plus the expected journey time of the longest significant journey will give the minimum warm-up time.

For instance, in **Figure 24** below the model becomes stable after 35 minutes. The longest expected journey in the model was 25 minutes. Therefore, the warm-up should be at least an hour.

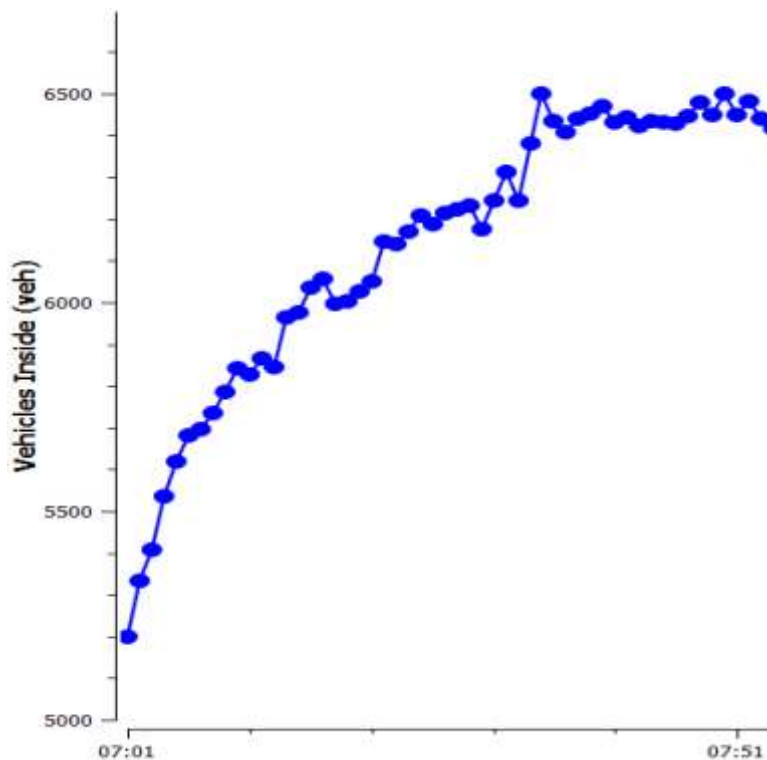

Figure 24: Analysing when the model becomes stable

3.2.4 Network Layout

An Aimsun Next network consists of a set of road Sections linked by Nodes and Turns at the road junctions. The method used to generate the network is determined by the available data sources. The two main methods are:

- Importing from GIS data or from another transport model; or
- Manually editing the network using an image as a background.

3.2.4.1 Network Import

The traffic network may be imported from a GIS system or from Open Street Maps (OSM). If this option is used, the data import must select which road categories are to be used in building the network and which are used to provide graphical annotation only. Once the network has been imported, it should be systematically checked to verify the road categories and attributes are correct and consistent. This is facilitated with the view modes in the TfL Aimsun Next Template (see [B3.1.2](#)) which can be used to display the static attributes of the network and hence provide a visual means of verifying the network consistency.

Each junction in the network should also be examined, and the node shaped to model the layout of the road network in detail. A typical OSM

import will only import the node connectivity, and not necessarily the node geometry and section shapes. Network geometry adjustment may be required as shown in [Figure 25](#) below.

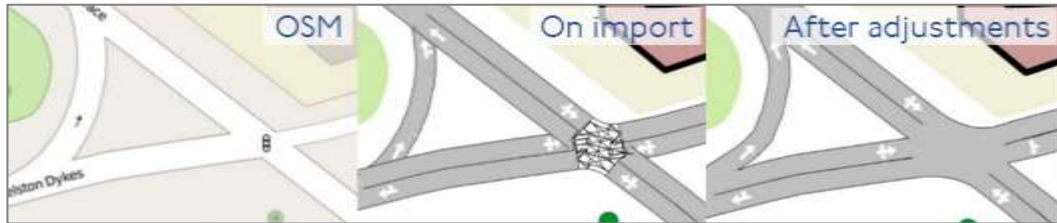

Figure 25: Illustration of network geometry adjustments

3.2.4.2 Transport Model Import

If the road network has already been coded in a pre-existing transport model, Aimsun Next provides a set of importers for most commonly used software to import it from that model. In particular, models can be imported from Vissim, Visum, SATURN and Cube. The Aimsun Next Help documentation provides useful information on which features are maintained and how they are mapped from each software package⁶⁵. The imported model should be systematically checked to verify the road categories and attributes are correct and, as above, that junction geometry is appropriate.

Depending on the source of the data, it may also be possible to import the OD matrices and the Aimsun Next centroid configuration (section [B3.4.4.1](#)) from the pre-existing transport model.

Calibration data used by other software packages will vary, as the parameters used to calibrate models are different and may not share common definitions. If a network is imported from another software package, it needs to be recalibrated in Aimsun Next.

3.2.4.3 Background Import

The traffic network may be coded on top of background images, such as aerial photographs and detailed topographical drawings. If this option is used, the images should be of sufficient detail and accuracy to give information on relevant network elements such as lane arrangements, stopline positions, give-ways and stop signs, bus stop locations, bus lanes, reserved lanes and lane markings. Before the network build begins it is essential that the background image is scaled correctly, and aerial photos are orthographically correct. As an additional safeguard it is suggested that a scale marker is included on the background which should be at least 100m in length.

It cannot be assumed that drawings and aerial photographs are up to date and accurate, so it is necessary to check layout details during site visits to confirm their accuracy.

3.3 Graphical User Interface

The New Project window, shown in **Figure 26**, is where the fundamental project settings are defined, including which aspect(s) of Aimsun Next is being used and the side of the road traffic drives on. It can also define the background to be used (section **B3.2.4.3**).

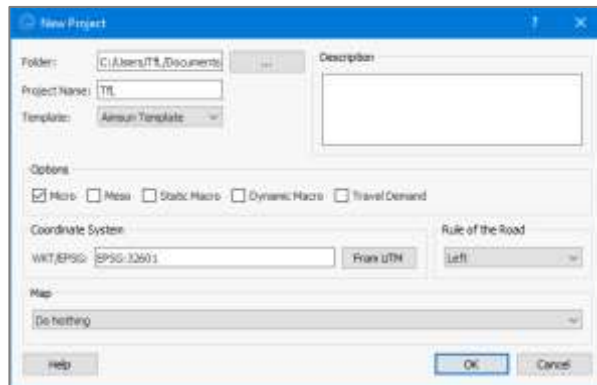

Figure 26: New Project window

The standard Aimsun Next view contains a number of windows which are used when building, calibrating and running a model. Model building tools can be found on the left of the network window, as can be seen in **Figure 27**.

Aimsun Next models are built from objects, for example Traffic Demand objects or Road Type objects, which can be edited in the Project window, on the right of **Figure 27**. This is where most of the model settings are defined. Double-clicking on an item in the list will bring up a dialog box relating to that object and right-clicking brings up a list of options including to create a new object.

Controls for running the model can be found above the network window and a log of actions below it.

The Layers window (bottom right of **Figure 27**) can be used to organise what is displayed and the order in which it appears. This can be useful to focus on particular features, such as the public transport system, or switch between different images or CAD drawings which may be used as backgrounds.

The objects which together determine the structure of the modelling project and how it is run are Scenarios, Experiments and Replications. Dynamic Scenarios hold the key data inputs required to run a simulation. These include the Traffic Demand, the signal Master Control Plan and Geometry Configurations. Additionally, settings related to the generation

of simulation outputs, the Aimsun Next API and the use of Strategies and Conditions can be found at Dynamic Scenario level.

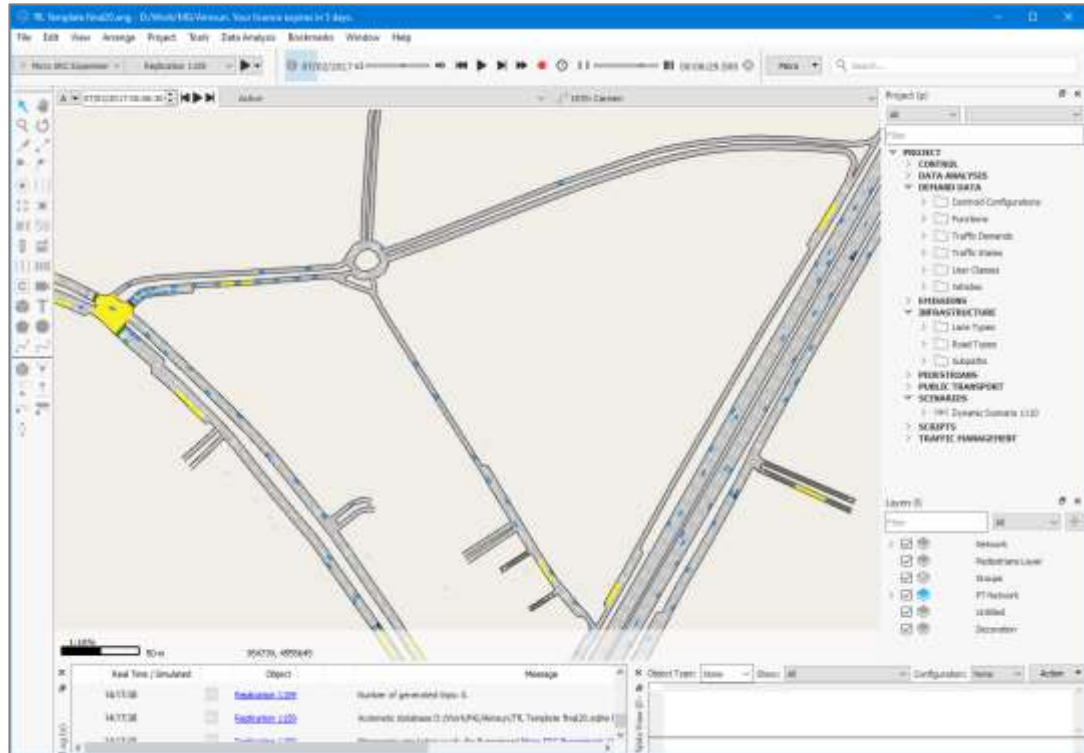

Figure 27: Aimsun Next 20 GUI

Scenarios include one or more Experiments which inherit the data and settings specified in the Scenario. When an Experiment is created, the simulator (microscopic, mesoscopic or hybrid) and Assignment Approach (for example Stochastic Route Choice or Dynamic User Equilibrium, section **B3.4.4**) are selected. The Initial Simulation State, along with driving behaviours such as Car Following and Lane Changing, and the Simulation Step are all set at Experiment level.

It is possible to test the performance of different simulation types and assignment methods by creating multiple Experiments within the same Dynamic Scenario.

An Experiment should contain multiple Replications which each use a different random seed, as described in section **B3.5.1**. These represent different simulation runs of the Experiment and in order to guarantee that the microsimulation results are statistically significant a sufficient number of Replications must be created. The final Experiment results are generated using an Average Replication.

3.4 Base Model Calibration

Once the input data has been collected, it can be used to build and calibrate the model. This section provides guidance on the structure of data in Aimsun Next and how to approach the model build.

A key part of building a properly calibrated and validated Aimsun Next model is observing the model while it is running. Accurate representation of vehicle behaviour is necessary for the model to fulfil its purpose. The animation features of Aimsun Next can be used during calibration to identify irregularities in driver behaviour that may adversely affect model operation. The model should be observed during multiple seeds to gain a rounded picture of its performance and provide reassurance that all the network elements are functioning correctly.

3.4.1 Model Parameters

There are certain parameters which should be agreed and set at the start of model development. Changing these parameters after calibration will invalidate model results.

3.4.1.1 Simulation Step

By default, the simulation step in Aimsun Next corresponds to the reaction time of all vehicles; values that should be used are in the range 0.6-1.0s. Other values should be used only if the study requires different vehicles to have different reaction times.

Note that in Aimsun Next, the simulation step is set in the Experiment and is independent of the controls in the view window which are used to adjust the speed and smoothness of the simulation animation. Similarly, the detection interval for loops is set in the Scenario independently of the simulation step and, if necessary, can be adjusted to satisfy requirements set by an external signal control system.

3.4.1.2 Units

Units can be set both at System and Project levels. They are accessed via Edit > Preferences > Localisation. If a Project is loaded then these preferences will act on this Project, if not then they will act at System level so all new Projects will have these preferences applied.

Units should be set to Metric. This means that all speed limits will need to be converted to kph before they are used.

3.4.1.3 Rule of the Road

As indicated in **B3.3**, the Rule of the Road, or the side of the road that vehicles drive on, is set in the New Project window. If necessary, it can also be changed in Edit > Preferences > Localisation, and should be set to Left.

3.4.2 Network

The Aimsun Next network structure is built using Sections, Nodes and Turns. Road Types define different sets of default behaviour parameters for Sections and Turns. The key elements of the network structure are described in this section, along with some guidance on network editing.

3.4.2.1 Sections

Sections are classified using Road Types (**B3.4.2.6**), a predefined set of templates for road parameters. The types used in the TfL Aimsun Next Template (see **B 3.1.2**) are:

- Bicycle Track / Pedestrian Way is included as a reserved road type separated from the main vehicle flow and for bicycles and pedestrians only;
- Motorway and dual carriageway Road Types are provided with speed limits of 40, 50, 60, and 70mph, with a capacity estimated at 1400veh/hr/lane;
- Rural Single road type with speed limits of 50 and 60mph, the typical rural speed limits; and
- Urban road type with speeds of 20, 30 and 40mph, with an additional narrow classification for a 30mph road type with reduced lane width and capacity.

The Section capacity will be altered automatically if the number of lanes of a Section is changed. Flares (Side Lanes) are not considered when calculating the capacity per lane or the new section capacity.

The use of a Section can be restricted to specified Vehicle Classes by defining its lane type. Lane types contain a list of reserved vehicle classes and specify whether their usage of a lane is optional or compulsory. The lane types used in the TfL Aimsun Next Template (see **B3.1.2**) are listed below, but more can be defined as needed:

- Reserved, Compulsory for Heavy Vehicles;
- Reserved, Compulsory Public Transport;
- Reserved for Bicycles; and
- Reserved for Congestion Charge.

Sections shorter than the length of the longest vehicle, or longer than several km, should be avoided. Sections are also divided into segments, which are the parts of the Section between the points used to build it. Segments can be either straight or curved in order to better fit the road layout. Segments can be used to define speeds, slopes or reserved lanes.

Bus lanes should be modelled as part of a multi-lane Section using lane restrictions. Bus lanes should not be modelled as separate Sections unless this reflects the road layout on street. The lane restriction can be removed with a Traffic Management action or an attribute override if it is necessary to model traffic when the bus lane is not in operation. If the reserved lane is the only one that allows a turning manoeuvre at the end of the Section, vehicles that want to make the turn will ignore the restriction. A specific point after which vehicles can enter the reserved lane can be set by un-reserving the last Segment of a Section.

A bus bay should be long enough to accommodate the longest public transport vehicle plus the minimum distance between vehicles parameter (**Figure 28**).

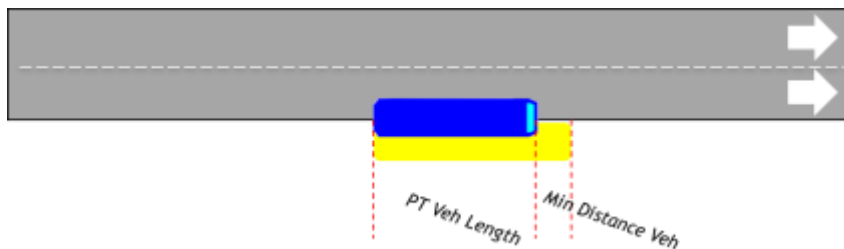

Figure 28: Bus bay length

3.4.2.2 Nodes and Turns

Nodes should accurately represent observed conditions including turning movements, banned turns, yellow boxes, lane to lane connections, advanced stop lines, and appropriate priority rules. Behaviour at nodes has an impact on congestion and vehicle journey times, especially in networks with give-way junctions and opposed movements at signalised junctions.

Lane connectivity between the arms of a junction should be set in accordance with road markings unless alternative lane use is observed on street. Model elements and values which can be adjusted are:

- Lane connectivity and geometry;
- Turn Speed: should usually be calculated automatically;
- Turn Capacity: should usually be calculated automatically;
- Attractiveness: should usually be equal to the capacity; and
- User-Defined Costs: values should be selected in order to manipulate the route choice in a balanced way so as not to over-penalise a route vs the alternatives and to match the observed traffic volumes.

Additionally, most Road Type Turn level parameters (section [B3.4.2.6](#)) can be overridden at Node level if different behaviour is required.

The Speed and Capacity values are used by the Route Choice functions in Aimsun Next Micro and Meso models depending on how the Attractiveness parameter has been defined.

Look-Ahead Distance and Additional Waiting Time Before Missing Turn ([Figure 29](#)) for movements should be carefully specified and calibrated as they play a major role in the lane changing behaviour of upstream Sections. There are three different zones in Aimsun Next, each one corresponding to a different lane changing behaviour. These are:

- **Zone 1** – The lane-changing decisions are mainly governed by the traffic conditions of the lanes involved;
- **Zone 2** – The intermediate zone. Vehicles which need to change lanes to make their desired turn adapt their speed to do so; and
- **Zone 3** – Vehicles urgently try to reach the lane they need to make their turn, by looking for gaps upstream and reducing speed. If necessary, they come to a complete stop in order to make the lane change possible.

The zones above are determined by the Look-Ahead Distance, which defines zone 2, and the Critical Look-Ahead Distance, which specifies zone 3. Outside the Look-Ahead Distance, a vehicle is considered to be travelling in zone 1.

An important parameter in defining zone 3 is Additional Waiting Time Before Missing Turn. If vehicles fail to make their turn after waiting their Maximum Give Way Time (section [B3.4.2.6](#)) plus the Additional Waiting Time Before Missing Turn, they continue in their current lane. This parameter can take values between -3600 and 3600. A negative value will reduce the original waiting time to a minimum of 0 seconds. The default value for this parameter would be 0 seconds, unless a particular problem is noted in the model, such as too many vehicles missing their turns (flagged as lost vehicles in the Node Attributes tab).

Distance zones should be used to make vehicles get into the appropriate lane in advance and stay in the lane. Using Solid Line lane markings at junction approaches is not recommended as vehicles that do not reach the lane they need in time will miss their turn.

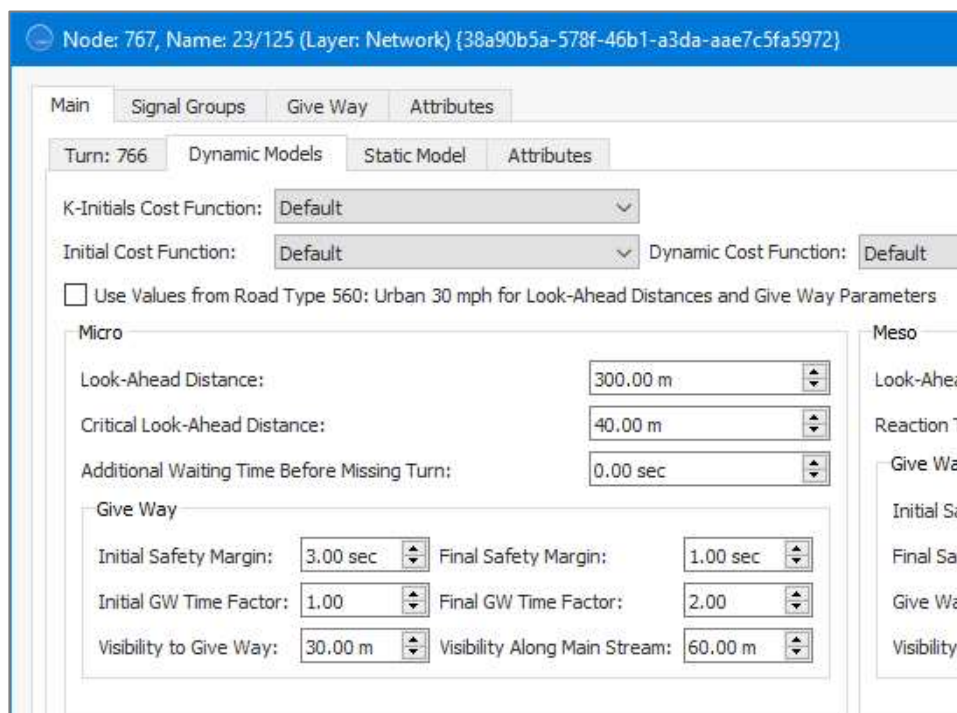

Figure 29: Extract from Node window showing Dynamic Models options

A Section preceding a turn that should be approached at reduced speed should be long enough to allow the vehicles to decelerate prior to entering the turn. Aimsun Next vehicles only become aware of the need for a change in speed in the Section immediately preceding a low-speed turn or Section, so short Sections are discouraged. If a short Section is needed, for a flare or other reason, in between a high-speed Section and a lower-speed turn, then the speed of that Section should also be reduced.

Turn geometry should be checked to ensure that there are no unnecessary conflict zones. In addition, the following features should be observed while the model is running to ensure they are correct:

- Sign associated to turns (for example Give Way, Stop or none);
- Priority rules between two turns;
- Stop line position (at the end of the Section, or an advanced stop line);
- Stop lines within a turn where queuing within a junction is allowed;
- Gap-acceptance model parameters; and
- Yellow box junction parameters.

To define priorities within a node (such as right turn against opposite through movement), specify a movement Warning as Give Way and add a stop line where the vehicles wait, even if there is no sign present on the physical network.

Stop lines controlling where vehicles stop at the end of the Section before moving through the Node should be located appropriately. The default position is at the end of the Section, but they may be moved individually to represent junction geometry or observed vehicle behaviour (**Figure 30**). Advanced stop lines should not be placed in the trajectory of another turn, even where signal timings would not give a conflict. This is to avoid gridlocking in future year scenarios where high levels of congestion may be predicted.

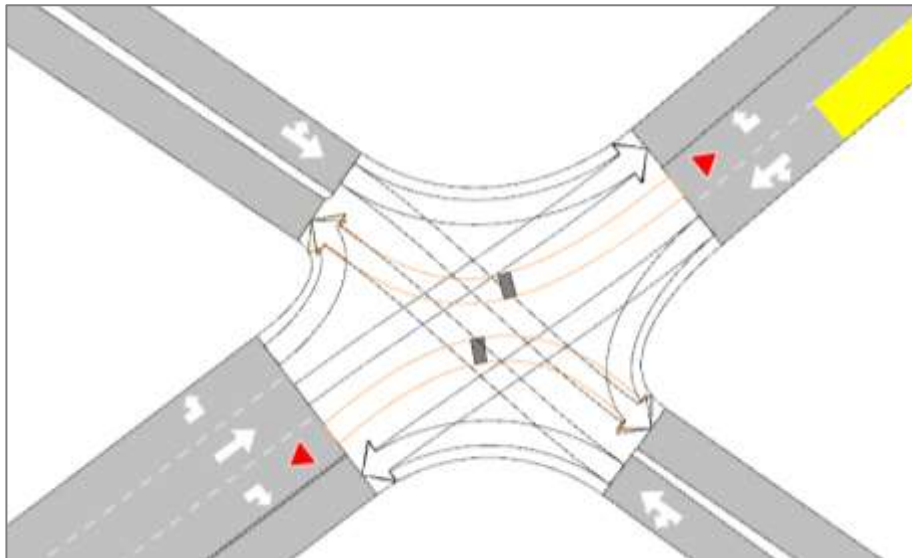

Figure 30: Advanced stop lines (dark grey boxes) at a traffic signal

3.4.2.3 Junction Geometry

Junctions with filters should use separate Sections for the filter where there is a hard barrier between the lanes and the distance from the start of the filter to the junction is greater than 10m.

If there is a waiting area within the central reservation, this should be coded as a Section in order to achieve the correct give-way behaviour at each part of the turn, as shown in **Figure 31**.

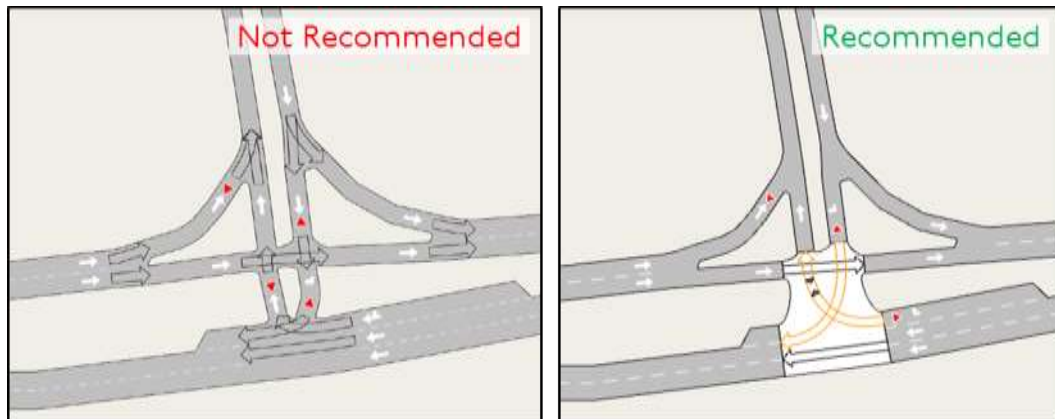

Figure 31: A junction with filters and a central reserve with the recommended construction method on the right

Sharp angles at the entrance or exit of a road Section (**Figure 32**) should be avoided as cars that are adjacent may be considered in different locations, one in turn and one in Section, which can cause issues with conflicts. They may be used in certain circumstances where the stopline is sharply angled, for instance at a roundabout or angled give-way. If this is the case, it is necessary to check that the model behaviour replicates on-street behaviour at this location.



Figure 32: Angled Section entrances and exits. The top row would be considered too sharply angled.

3.4.2.4 Side Lanes

Side Lanes are used to model on-street flares, but should also be used to replicate any kind of merging or diverging behaviour. This section contains advice on the use of Side Lanes.

Connections between lanes where multiple lanes are connected to a single downstream lane, causing conflicts, should be avoided. Instead, Side Lanes should be used to better replicate co-operative behaviour (**Figure 33**).

These connections may be justified in certain circumstances, where on-street behaviour necessitates, however their usage is discouraged. The Side Lane on a merge / diverge should extend to the length of the taper on street.

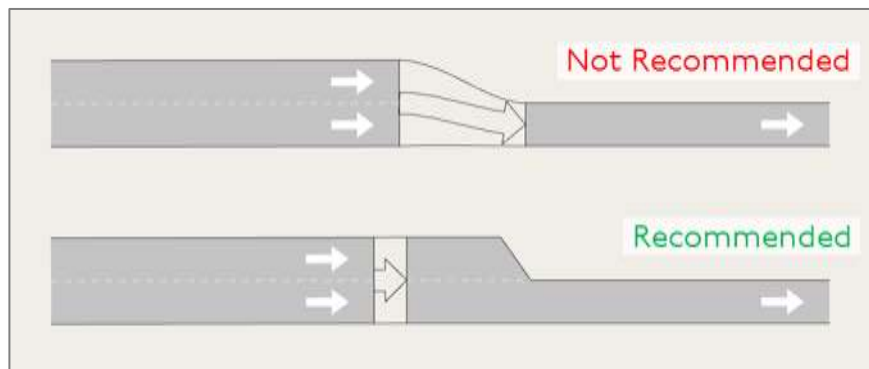

Figure 33: Use of a Side Lane to model a merge

Where there is a Side Lane on the approach to a turn, the Look-Ahead Distance and Critical Look-Ahead Distance must be greater than the length of the Side Lane. This is to ensure queues propagate from the entrance to the Side Lane. In addition, the Side Lane should not exceed half the Section length to ensure that vehicles have time to slow down in order to change lane, as shown in **Figure 34**. Since vehicles only consider the need to slow down to make a lane change on entry to a Section, if their speed exceeds the speed needed to safely change lane, then the vehicle may not be able to change lane and will therefore miss the turn. If it is not possible to make the Section long enough then the speed on the upstream Section may need to be adjusted.



Figure 34: Side lane lengths. The Section on the left is too short.

On-ramps or lanes that drop (with a merging action) should be coded as a single Section with a Side Lane at the start (Figure 35);

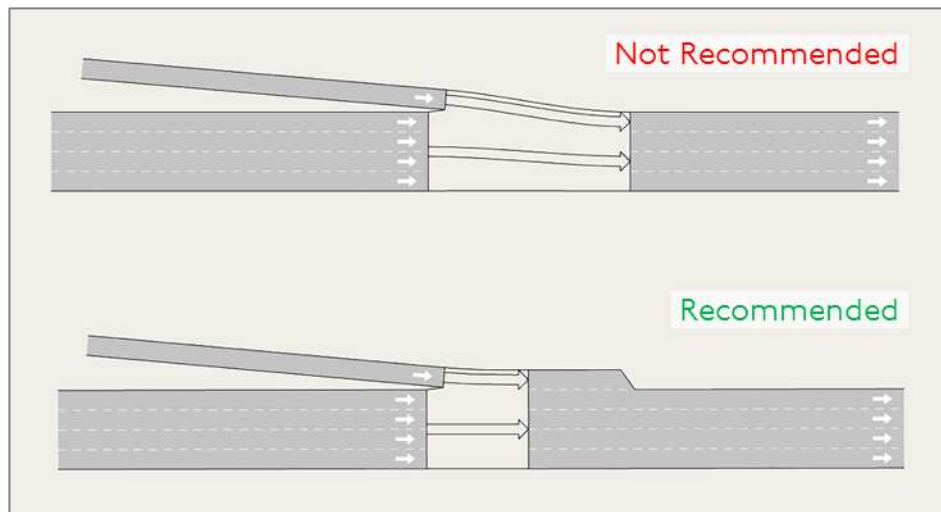

Figure 35: Section On-Ramps with correct Side Lane usage below

For more complex merges, such as ghost island merges, multiple sections should be avoided, instead solid lines and lane connections should be used (Figure 36).

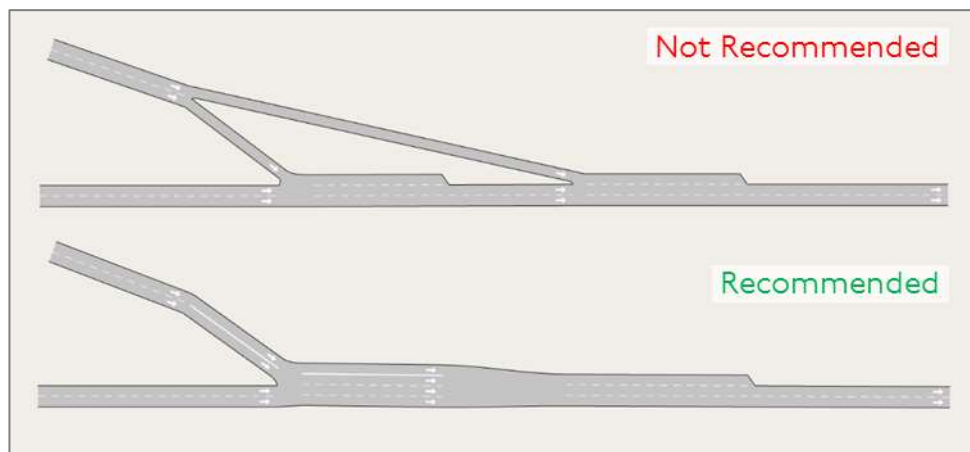

Figure 36: Complex merges

3.4.2.5 Roundabout Geometry

It is recommended that different roundabout types are modelled as described below. This is in order to create consistency for future year testing and to best replicate UK-wide behaviour. There may be cases where these designs are not appropriate, but these should be treated as the exception. This advice applies to priority roundabouts only and not those with signal control.

A mini roundabout should be coded as a Node (**Figure 37**), with all turns assigned as Give Way in the Warning column. Use give-way parameters to ensure that traffic gives way to the right. These can be accessed via Node properties and the Give Way tab.

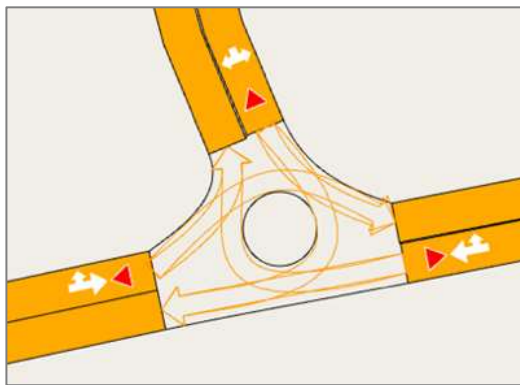

Figure 37: Mini roundabout coded as a Node

A roundabout with a single lane can be modelled using Aimsun Next's roundabout tool (**Figure 38**). This automatically generates Nodes and Sections in a circular layout connecting all Sections that are selected. These can then be modified as normal.

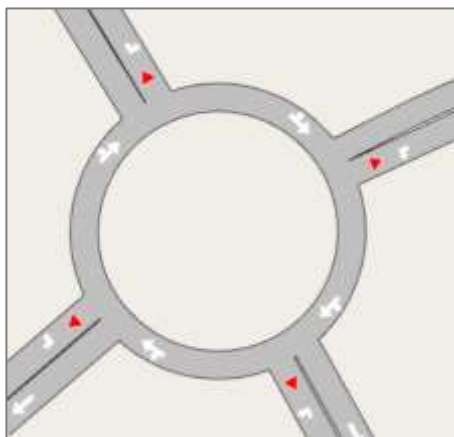

Figure 38: A single lane roundabout generated using the roundabout tool

A priority roundabout with more than one circulation lane should be modelled as a set of give-way junctions. To ensure that the lane assignment is correct from all entries to all exits it can be coded by using a section between the entry and exit arms of the same approach and a node between each arm of the roundabout, as demonstrated in **Figure 39**.

Each possible path that could be taken through the roundabout should be checked to ensure that the lane assignment is correct. Where the roundabout has three circulation lanes, the Advanced Node editor can be used to ensure that the correct lanes are connected.

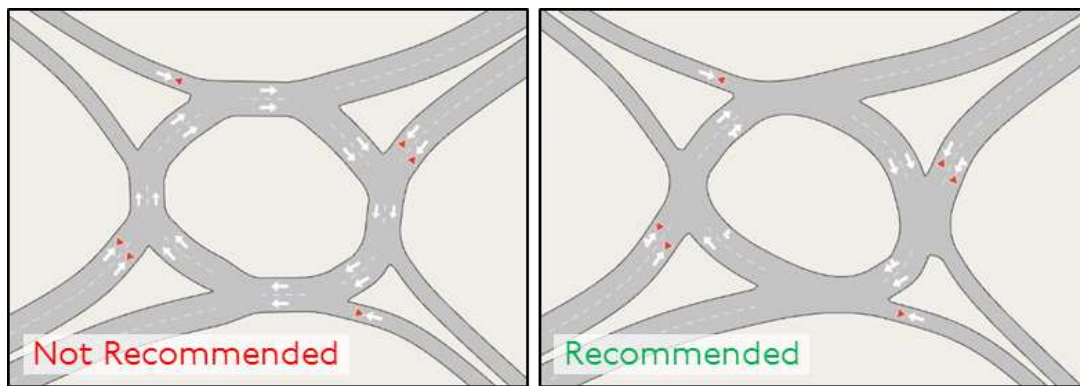

Figure 39: A multi-lane roundabout with the recommended construction method on the right

The Critical Look-Ahead Distance should be at least the circumference of the roundabout plus the Visibility to Give Way, in order that vehicles are in the correct lane on entry to the roundabout. The Look-Ahead Distance should be greater than this value.

3.4.2.6 Driving Behaviour

In Aimsun Next, the parameters that control vehicle behaviour can affect:

- **All vehicles at all locations** – these are set in the Experiment;
- **A subset of vehicles at all locations** – these are set in Vehicle Types;
- **All vehicles at a subset of locations** – these are set in Road Types; and
- **All vehicles at a specific location** – these are set in a Section or Turn (overriding the values set in the Road Type).

Experiment, Vehicle Type and Road Type parameters should be agreed and set at the start of model development. If necessary, new Types can be added later. Section and Turn parameters should be adjusted locally where required during the calibration of the Base model. Once the model is calibrated, changes to any of the parameters will invalidate the results.

The TfL Aimsun Next Template (see [B3.1.2](#)) contains default values for the parameters associated to common types of roads (freeway, ramp, arterial, urban road) and common types of vehicles.

Road Type and Vehicle Type parameters can be accessed by double-clicking the relevant item in the Project window and then navigating to the appropriate tab or sub-tab. [Figure 40](#) and [Figure 41](#) below attempt to describe the locations of some of the key parameters.

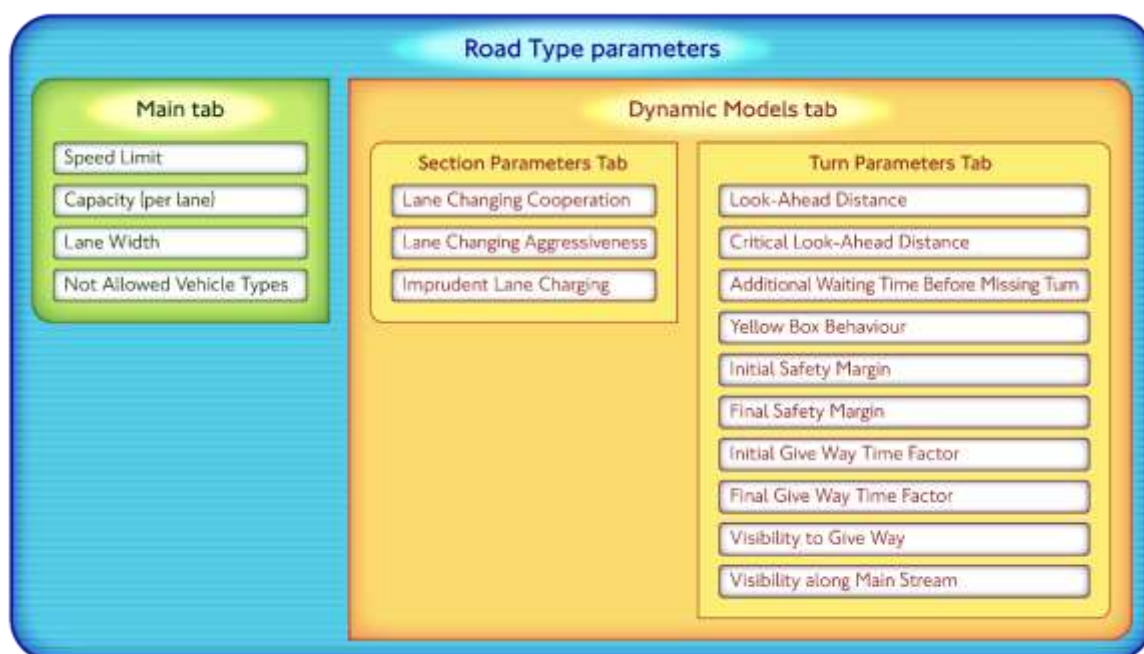

Figure 40: Road Type parameters

These parameters should only be changed if there is sufficient justification and it is preferable to generate new Vehicle or Road Types, to make commonly used changes readily auditable, rather than edit the default types.

It is recommended that Section and Turn parameters are inherited from the Road Type, rather than being defined locally, during the building of the model. Section and Turn parameters should only be modified during the calibration process. If a parameter is to be changed at several locations, it is better to change the Road Type or define a new Road Type rather than changing the local parameter at all locations.

To avoid complicating the maintenance and review of the model, the number of additional Vehicle or Road Types used should be kept to a minimum. Any changes to Vehicle Types, Road Types or Section and Turn parameters should be agreed with the MAE.

Vehicle Type parameters

Main tab

- Length
- Width
- Maximum Desired Speed
- Classes

Dynamic Models tab

Main tab

- Speed Limit Acceptance
- Clearance
- Maximum Give Way Time

Experiment Default tab

- Reaction Time
- Reaction Time at Stop
- Reaction Time for Front Vehicle at Traffic Light

Microscopic Model tab

Main tab

- Max Acceleration
- Normal Deceleration
- Max Deceleration
- Safety Margin Factor
- Lateral Clearance
- Max Lateral Speed

Car-Following Model tab

Main tab

- Sensitivity Factor
- Favours Stop And Go
- Maximum Give Wait Time

Two-Way Overtaking Model Tab

- Margin for Overtaking Manoeuvre

Lane-Changing Model tab

- Overtake Speed Threshold
- Lane Recovery Speed Threshold
- Percentage Staying in Overtake Lane
- Imprudent Lane Changing
- Cooperate in Creating a Gap
- Allow Vehicles Non-Lane Based Behaviour
- Aggressiveness Level
- Look-Ahead Distance Factor

Figure 41: Vehicle Type parameters

3.4.3 Traffic Data

This section contains information on how traffic is modelled in an Aimsun Next model. This includes defining the characteristics of individual vehicles and specifying how vehicles enter the model. There is also some information on modelling public transport, cyclists and pedestrians.

3.4.3.1 Vehicle Types and Classes

Vehicle Types are used to represent vehicles with different physical characteristics and behaviour. They may also define access to restricted lanes in the model, such as bus lanes. Vehicle Types may also be used to refine the Traffic Demand by disaggregating the demand matrices by Type or groups of Types.

Vehicles Types can be grouped into Vehicle Classes, which are only used in reserved lane definitions.

The vehicle characteristics should not be adjusted without justification. Other Vehicle Types can be created if supported by observation, survey results or where required by the scheme. For example, a scheme may be concerned with speed enforcement measures and so an additional Vehicle Type could be included to model the behaviour of speeding vehicles.

When creating a new Vehicle Type, it is essential to assign it to the correct class. A new Public Transport Vehicle Type must be assigned to the 'Public' class so that it can use a reserved lane.

3.4.3.2 Vehicle Network Entry

The time interval between two consecutive vehicle arrivals at the entry points in the network depends on the arrivals profile parameter selected.

The arrival profile is set at an Experiment level but may be overridden for individual centroids for OD traffic demand, or for individual Sections where demand is controlled by Traffic States (section [B3.4.4](#)). Different options available, as shown in [Figure 42](#), are:

- Exponential distribution, the default option;
- Normal distribution;
- Uniform distribution;
- Constant, arrivals at a regular fixed time interval; and
- ASAP, As Soon As Possible, meaning whenever there is a space on the receiving road section.

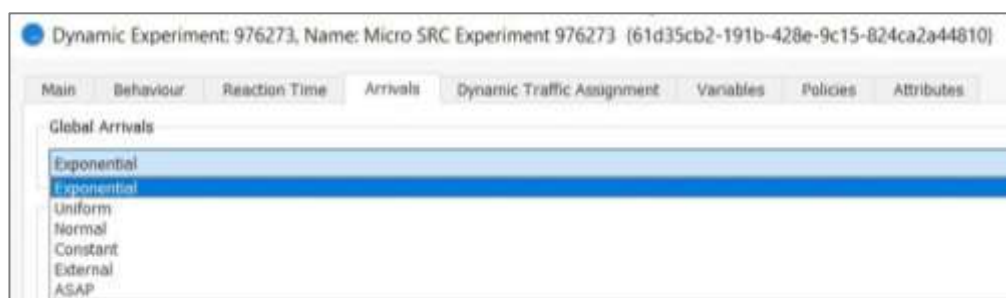

Figure 42: Arrival profile options

The exponential distribution is a default option to represent typical traffic conditions (unless the data collected shows otherwise), the constant distribution may be used for gated traffic entry, and the ASAP mode is useful when simulating intensive demand such as at a car park exit after an event. If the arrival algorithm is changed from the default exponential distribution, this should be noted in the project report.

3.4.3.3 Warm-Up Demand

A warm-up period is specified to populate the network realistically with vehicles when measurements start. The traffic demand should be profiled by using multiple demand items for each Vehicle Type so that the traffic loading to the network varies over time and follows a profile that characterises the pre-peak, peak and post-peak conditions. Loading a flat demand composed by a single Traffic State or OD Matrix per Vehicle Type does not allow the model to reproduce the dynamics of queue building and dispersion that can be observed in reality. Ideally, the simulation should start and finish without congestion in the network for a proper comparison with future scenarios.

The warm-up may be modelled by preloading the network with a saved initial state or by running the simulation for a given amount of time using either a specific warm-up demand or the same demand in use at the study period start time. The decision about which warm-up method to use must be documented in the model report.

3.4.3.4 Public Transport

Public transport lines should be modelled as timetabled so either TfL website data⁶⁶ or iBus data (section **B3.2.2.5**) can be used. If iBus data is used, care should be taken to use the scheduled rather than actual data. This is so that any impact is part of the model performance, rather than built in.

Public Transport routes may be imported from a General Transit Feed Specification which defines a common format for Public Transport schedules and associated geographic information. Alternatively, they may be entered through custom scripts or, in a small model, they may be edited manually. **Figure 43** below shows the Public Transport Line data entry window.

Frequency-Based bus departure times should be made variable with a random perturbation in the time interval to prevent all buses appearing in the model at the same time. If bus termini are included, schedule conditionality can be considered, where one service will not depart until another has arrived.

66 <https://tfl.gov.uk/travel-information/timetables/>

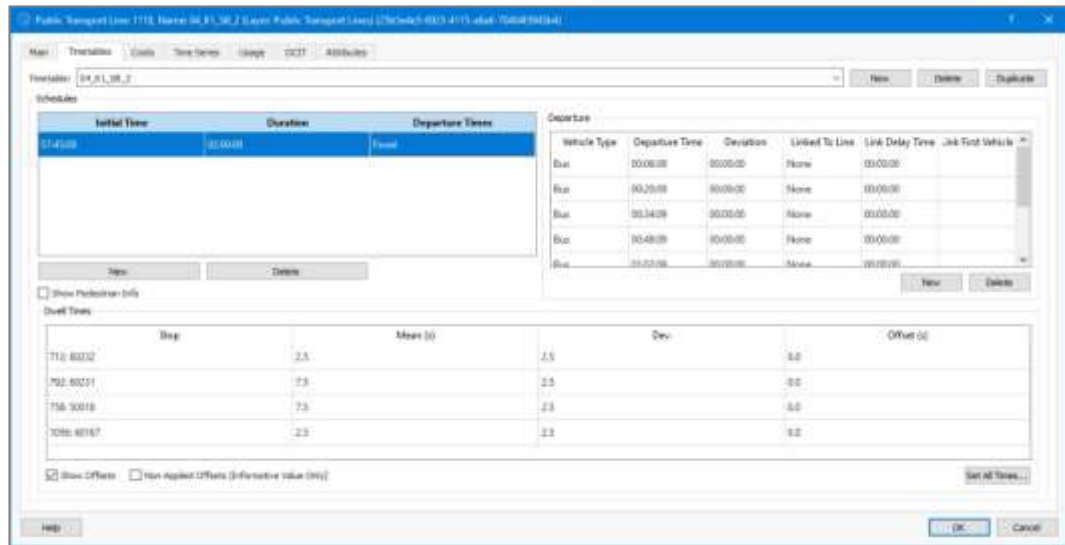

Figure 43: Public Transport Line timetable window

3.4.3.5 Pedal Cycles and Motorcycles

Aimsun Next 20 includes a lateral behaviour model which can be used to simulate the behaviour of powered and non-powered two-wheelers. Although it can model Non-Lane Based movements, it focuses on large-scale performance and aggregated outputs rather than realistic vehicle trajectories⁶⁷. This should be borne in mind when considering the outputs and purpose of the model.

In order to make use of Non-Lane Based behaviour it must be activated at Experiment, Vehicle Type and Section levels:

- At Experiment level, the option is found under the Behaviour tab;
- At Vehicle Type level, the option is in the Lane-Changing Model sub-tab, which is in the Main tab of the Microscopic Model tab; and
- At Section level, the option is on the Dynamic Models tab.

A combination of these settings can be used to produce the desired results at each location in the model.

3.4.3.6 Pedestrians

Pedestrian modelling is required when modelling uncontrolled or zebra crossings, public transport vehicle interaction and signalised crossings with pedestrian demand calls. The number of pedestrians must be calibrated through site observation and, as with other network bottlenecks, sample counts of traffic passing the crossing will assist model calibration.

Pedestrians may be directly included in an Aimsun Next model from Aimsun Next 20 onwards. Earlier versions of Aimsun Next had the facility for pedestrians modelled using LEGION, with the LEGION for Aimsun simulator, and this is still available in Aimsun Next 20 where more detailed pedestrian modelling is required. It is also possible to model pedestrian phases at junctions without a full pedestrian simulation, and information on this can be found in section [B3.4.5.3](#).

3.4.4 Routing

The traffic demand in Aimsun Next is defined by means of a Traffic Demand object which may be coded in two ways: OD Matrices or Traffic States. In addition, it is possible to use Path Assignment outputs from existing Static Assignments or DUE Experiments as input files to define routing. A Static Assignment, in Aimsun terminology, refers to a macroscopic-level model which uses aggregated flows rather than individual vehicles. The choice of Traffic Demand and, if relevant, Path Assignment Plan is set at Scenario level, and settings relating to routing can be found on the Dynamic Traffic Assignment tab at Experiment level.

On the Dynamic Traffic Assignment tab, the Interval refers to how often the shortest path is calculated by whichever algorithm is chosen. The Number of Intervals defines how many intervals of previous data will be considered during the calculation.

3.4.4.1 OD Matrices

An OD Matrix provides the number of trips that depart from each origin zone to each destination zone for each Vehicle Type and time interval. To use an OD Matrix, a set of Centroids must be created and connected to the road network as these define the structure (number of rows and columns) of the OD Matrices. Aimsun Next supports working with multiple sets of Centroids (Centroid Configurations) if the study requires the use of different zoning systems for different traffic components (for example, cars and pedestrians).

Centroids can be connected to more than one Section using multiple Connectors. This should be avoided if information is known about all the locations. By default, the Connectors use a gravity model to assign the 'best' Connector to use for a vehicle to make its journey. If multiple Connectors are used, they should not be connected to the same Section or within Nodes. Percentages should not be used to define which vehicle uses which Connector. If the default solution does not give good splits, the Centroid should instead be split, and the demand adjusted accordingly.

Centroid Configurations and OD Matrix specification can be found in the Demand Data section of the Project. Traffic Demand objects can be used to apply different matrices to different time periods in the model.

3.4.4.2 Traffic States

A Traffic State provides input flows at all road Sections and turning proportions at all Nodes for each Vehicle Type and time interval. Aimsun Next then allocates vehicles to a turn, based on the need to satisfy the turning proportions at that junction without reference to a path or a destination. Due to the high saturation of London's road network, it is not recommended to use this type of traffic demand if Static Assignment or DUE Experiments are used as it is hard to achieve convergence. In addition, journey time data collection is difficult due to the fact that vehicles may not complete the journey time sections. Therefore, Traffic States are only acceptable if there is no reason to model route choice or journey times.

Traffic States are specified in the Demand Data section of the Project. Traffic Demand objects can be used to apply different Traffic States to different time periods in the model.

3.4.4.3 Route Choice Method

If the Traffic Demand is coded with OD Matrices and the modelled network provides routing alternatives, the route choice method used plays a fundamental role in the validation of the model. Where alternative routes do exist, it is necessary to carefully consider the benefits they may provide, and balance this against the added complexity introduced during Base model calibration and option / scheme testing.

TfL does not advise the use of dynamic routing unless fixed routes cannot be established with accuracy. In cases where dynamic routing is justified, the methodology used should be agreed and documented.

Aimsun Next can route vehicles:

- on the shortest paths in the network;
- on paths determined by a Stochastic Route Choice (SRC) method;
- on specified OD Routes;
- on paths derived from a prior validated Static Assignment Experiment;
- on paths derived from a prior Dynamic User Equilibrium (DUE); or
- on combinations of these options.

The selection of a route choice algorithm and whether input path files should be calculated and re-used depends on the application of the model, on the number of routing alternatives available in the modelled area and on observation of vehicle behaviour. An indication of when each of these options should be used can be found in **Table 7** below, which should be considered in conjunction with the following points:

- For the SRC method, other than the limited cases mentioned in **Table 7**, it is recommended that the Logit model is used, unless it is known that there are lots of overlapping paths with small differences, in which case the C-Logit model should be used. The Logit parameters should be used to calibrate the route choice. The choice of SRC Model and accompanying parameters can be found in the Stochastic Route Choice section of the Dynamic Traffic Assignment tab in the Experiment settings;
- If paths from another assignment, for example a Static Assignment, are used (for example if a Path Assignment Plan is selected in the Scenario), this assignment must be calibrated / validated for the same Base year as the model being developed. The assignment will generate a path file (*.apa) which is used as an input to a Path Assignment object. The Path Assignment Plan sets a Path Assignment for each time interval in the model and can be used to combine multiple Path Assignments;
- The percentages defining proportions of vehicles using different route choice methods can be found in the Fixed Routes section on the Dynamic Traffic Assignment tab in the Experiment settings. The columns are cumulative, so the Following OD Routes column acts on all vehicles and the Following Input Path Assignment column acts on the remaining percentage. If the last column is not 100% then the remaining vehicles follow a path based on the route choice model; and
- Usually, a path is assigned to each vehicle when it is generated and it is fixed for the duration of the trip. However, there is an option to

define a proportion of vehicles that can update their paths on entry into the network or during their trip. This can be activated by checking the En-Route Path Update option in the SRC settings and then defining the percentages on the corresponding tab.

Table 7: Decision table for determining route choice method in Aimsun Next

Model Type	Route choice
Single junction or corridor with limited route choice. There is no need to measure journey times or evaluate route changes due to future developments.	Use traffic demand based on a Traffic State.
Single junction or corridor with no route choice.	Run SRC with the Model set to 'Fixed Using Travel Times Calculated under Free-Flow Conditions'.
Route choice is available in the model and congestion has an effect on travel times.	Run SRC with the Model set to 'Fixed Using Travel Times Calculated at the End of the Warm-Up Period'.
Complex route choice is available in the model and there is consistent congestion.	Run SRC with an interval time that is the length of the modelled period so that only one set of trips is calculated.
Route choice is available but some drivers are observed to use paths other than those generated in the static initial paths set.	Use one of the above methods for SRC and optionally add user defined OD Routes and assign the proportion of vehicles on designated trips to these routes.
Route choice is available in the model and congestion varies over the modelled period.	Run SRC with a sensible interval time, such as 15 minutes.
Route choice is available in a large model where there is predictable but consistent congestion which drivers anticipate and route to avoid before it occurs.	Use paths from a Static Assignment or use a DUE route choice / Path Assignment with one interval.

<p>Route choice is available in a large model where there is predictable and varying congestion which drivers anticipate and route to avoid before it occurs.</p>	<p>Run DUE with a sensible time interval. Use varying demand in the OD Matrices to model the changing demand over the period.</p>
<p>Route choice is available in the model. Some drivers are aware of congestion, others are not.</p>	<p>Generate a path file from a DUE Experiment or a Static Assignment. Run a simulation in which the percentage of drivers who have no access to dynamic travel time information use paths from the path file, and others follow SRC generated paths.</p>
<p>Route choice is available in the model, there is congestion, recurrent conditions are modelled, the study requires the capture of routing behaviour of drivers who have access to pre-trip or on-trip travel time information.</p>	<p>Generate a path file from a DUE Experiment or a Static Assignment. Run a simulation in which the percentage of drivers who have no access to dynamic travel time information use paths from the path file, drivers who have access to pre-trip information follow SRC generated paths and drivers who have access to on-trip information receive En-Route Path Updates.</p>
<p>Route choice is available in the model, there is congestion, non-recurrent conditions are modelled (examples include accident or construction).</p>	<p>Generate a path file from a DUE experiment or a Static Assignment representing recurrent conditions (for example no accident, or no construction). Run a simulation in which the percentage of drivers who have no access to dynamic travel time information use paths from the path file, drivers who have access to pre-trip information follow SRC generated paths and drivers who have access to on-trip information receive En-Route Path Updates. Use Traffic Management actions to divert vehicles from their paths (potentially because they see a VMS or other messaging).</p>

3.4.5 Signal Control

Aimsun Next has a few different methods of controlling signals. Which method is used for a particular modelling project depends on the required outcomes and also the complexity of the project and signal control strategies.

3.4.5.1 Controller Logic

The options for the different forms of signal control are:

- **Uncontrolled** – The Node is managed by stops and give-ways. No traffic signal control present at the Node;
- **Fixed** – The Node is managed by traffic signals with fixed timings. Timings may be derived from LinSig or TRANSYT models or average timings from UTC control systems;
- **Actuated** – The traffic signal stages may be called when vehicles pass over detector loops. Actuated signals must be used if demand-dependent signal stages are required;
- **External** – External control policy implemented using the Aimsun Next API Extension;
- **Unspecified** – A node with no control plan information defined. This type is used when working with different zones to let the simulator know that the control plan for the previous zone is still in use; and
- **Ramp Metering** – A node may use a metering to regulate the flow of traffic, for example a ramp metering at a motorway on-ramp.

The choice of controller logic must be documented and justified in terms of the intended purpose of the model.

As Aimsun Next uses different traffic signal terminology to UK practice.

Table 8 shows definitions of the terminology used in Aimsun Next.

Table 8: Traffic signal terminology used in Aimsun Next

Aimsun Next	Definition
Signal Group	A set of turn movements that are controlled by the same indications of traffic signals. Phase in UK practice.
Phase	A time period for which the state of all signal groups is same at that node. Stage in UK practice.
Offset	Time displacement that is applied to the node's cycle when the control plan is initialised.
Cycle time	Time period to complete the full sequence of stages.
Green to red: Yellow time	Amber time.
Red to green: Yellow time	Red / Amber time.
Red percentage (%)	Percentage of green to red yellow time that the vehicles consider as red. This depends on driver behaviour.
Flashing Green	Used for display purposes only. It means the signal group will show flashing green instead of a full green signal.
Interphase	Time to model the fixed clearance time between two phases. Interstage in UK practice.

3.4.5.2 Demand-Dependent Stages

If a model features demand-dependent stages, care should be taken to ensure that the turning volumes match those observed in reality, as they impact not only Section volumes, but also signal timings. The modelled demand dependency should be compared to demand-dependent stage frequency data to calibrate the demand dependency percentage (section [B2.3.8.5](#)). Warm-up and cool down periods should be excluded from the data collection.

If the Vehicle Actuated (VA) logic cannot be modelled using the actuated signals option in Aimsun Next, or the public transport priority logic cannot be coded using the pre-emption option in Aimsun Next, the API should be used to emulate the actual logic.

Figure 44 shows the data entry window for an Actuated Node.

Figure 44: Vehicle actuated (VA) signal control

3.4.5.3 Pedestrian Phases

If pedestrians are not explicitly modelled but pedestrian stages are required, there are three options:

- Code a set of pedestrian crossings at the junction using the Pedestrian Crossing Editor. Use the pedestrian centroids to define entry / exits and define an appropriate number of pedestrians wanting to cross. If no data is available on the number of pedestrians, the number of times that a stage is called within an hour can be used to derive an arrival rate. These crossings can then be added to a signal group and coded as an actuated phase. No detectors are required;
- Code fixed pedestrian phases at each cycle (with double-cycling if the phase is not called every cycle); or
- Write an API application to call the pedestrian phase as required by the API code logic.

3.4.5.4 Give-Ways and Stoplines

Give-ways and stoplines have a significant impact on the throughput at a signalised junction as they define the priority rules between conflicting movements (for example right turn against opposing through route) and the possibility of queuing inside the junction area. Therefore, they are key aspects in calibrating an Aimsun Next Base model to replicate on-street behaviour.

The following parameters are used at a signalised junction to model vehicle movements. Some of them are described in more detail in section [B3.4.2.2](#):

- OD lanes of each turn;
- Lane selection and lane change distance zones of each turn;
- Position of the stoplines at the end of the section;
- Give Way assigned to each conflicting movement;
- Relative priority between two conflicting movements;
- Trajectory (shape) of each turn;
- Conflict areas between turns;
- Intermediate stoplines along a turn;
- Yellow box junctions; and
- Yellow box speed.

With respect to turns that are assigned a Give Way, the gap acceptance parameters may be adjusted to reflect on-street observation. [Figure 45](#) shows the data entry window for assigning turn parameters.



Name	External ID	Speed	Yellow Box Behaviour	Zones	Warning
766 NE-W		Auto 46.7	Yes	RT 277.8/41.7/100	Give Way
770 NE-SE		Auto 20.9	Yes	RT 277.8/41.7/100	
771 W-SE		Auto 50.0	Yes	RT 277.8/41.7/100	
773 W-NE		Auto 33.1	Yes	RT 277.8/41.7/100	
774 SE-W		Auto 27.1	Yes	RT 277.8/41.7/100	
775 SE-NE		Auto 18.0	Yes	RT 277.8/41.7/100	Give Way

Figure 45: Assigning turn parameters

3.5 Base Model Validation

Base models must demonstrate that they replicate observed conditions to a sufficiently high level of accuracy, as described in **B2.4.1** and **B2.4.2**.

Aimsun Next uses Real Data Sets to load observed data to be compared with simulation outputs. A Real Data Set object should be included in the Aimsun Next model file and used during calibration to identify where the model is close to calibration and where there are still significant errors.

3.5.1 Randomness

A microsimulation model is run for several Replications of the same Experiment using a range of initial seeds to represent day-to-day variations in traffic conditions.

To avoid a biased result, both calibration and validation should be conducted using a minimum of twenty Replications (see **B2.1.5**).

The set of seeds used in the Proposed model and the Base model should be the same. Replications can be run by selecting them in the Project window, right-clicking and selecting the appropriate run option.

The variation in results between Replications should be documented in the model report. The mean and standard deviation of results from multiple Replications should be provided in the validated Base model to demonstrate the variability between simulation runs. The average results can be found in an Average Replication, which can be run independently on the results from specified Replications.

3.5.2 Validated Model Requirements

Validated Base models are submitted during AMAP Stage 3, and all validation threshold figures quoted are from the latest version of MAP, at the time of publishing⁶⁸. Section **B3.7** explains Aimsun Next model outputs in more detail, and the methods described there can be used to indicate that a model has been calibrated and validated according to the thresholds given in this section.

⁶⁸ SQA-0685, Model Auditing Process (MAP) – Traffic Schemes in London Urban Networks, Version 3.5, Transport for London, March 2017

3.5.2.1 Traffic Flows

MAP recommends that, when comparing modelled flow to observed flow volumes, the target is for GEH (**Appendix II**) values less than five. The report should show all observed and modelled flows together with calculated GEH values. Modelled flows should be averaged over multiple Replications, as described in section **B3.5.1**.

All entry Sections into the network are required to show modelled flows within 5% of observed flows to ensure that all assigned vehicle flows are being successfully loaded into the network during the peak modelled period.

When using traffic counts for validation, the counts measured at road Sections and/or for individual turning movements should be included in the Aimsun Next model as a Real Data Set.

3.5.2.2 Saturation Flows

Saturation flows are used to compare the discharge behaviour of the model at junction stoplines with on-street observation. All observed and modelled saturation flows should be tabulated and the percentage error between the two values reported. Modelled saturation flows values should be within 10% of observed values, or values used in any corresponding validated and approved TRANSYT or LinSig modelling.

During the process of calibration, time headways should be studied. This can be done using the Discharge Rate Evaluation Extension (Micro) extension (section **B3.7.2.2**). The discharge rate evaluation files should be filtered to remove measurements that do not correspond to saturated conditions (for example where there are very large headways). M&V can supply a spreadsheet-based tool which aids the filtering and processing of vehicle headway data. Alternatively, model can be viewed as on street.

Wherever saturation flows have been measured on street during the relevant time period, providing the model is a fair representation of on-street conditions, it should be possible to measure saturation flows from the Aimsun Next model. An inability to collect saturation flow data across a stopline in Aimsun Next where it was successfully collected on street should be an indication that the model is not performing as desired.

It is possible, however, that saturation flows were measured on street at different times of the day in more appropriate conditions, or that RR67,

possibly with a local factor (section [B2.3.9.1](#)), has been used to calculate a saturation flow.

There are times when a saturation flow cannot be measured within Aimsun Next that is representative of on-street conditions, for example, where a stopline has low flows crossing it, or where downstream congestion causes queuing which prevents free-flowing movement over the stopline. If this is the case it is acceptable to make a copy of the model and modify it appropriately to generate the necessary traffic conditions. This may be by adding vehicles or removing causes of congestion. This model should be submitted for auditing along with the main model, and appropriate reference made in the model report.

3.5.2.3 Demand Dependency

All demand-dependent stages within the network should show a frequency that is within 10% of that observed on street. The average count for each peak modelled should be reported alongside the control plan statistics produced by Aimsun Next in the MICONTR0LPHASEEVENTS table of the output database. This data is collected by selecting Phases Events data collection in the Scenario as shown in section [B3.7.1](#).

3.5.2.4 Journey Times

Modelled journey times should be taken from an average of twenty replications, as described in section [B3.5.1](#), and be within 15% of surveyed on-street journey times (section [B2.1.5](#)). Validating over longer journey time distances is favoured over shorter ones although long journey times can be broken into smaller parts for analysis.

Journey times can be collected using either Groupings or Subpaths, as described in section [B3.7.2.3](#). Which of these methods is chosen will depend on the on-street journey time surveys, as the data collection in the model should match the data collection on street as closely as possible and be compared using a similar method of aggregation.

3.5.2.5 Queue Data

Given the difficulty of measuring queue lengths on street in the same way as in a model, a direct comparison of simulated versus observed queue lengths is not a validation criterion; journey time validation is a more reliable indicator of congestion levels. Queues should, however, appear in the model at the same locations and during the same time periods as they are observed in reality, and queuing behaviour in the model should be consistent with site observations.

Queue survey data is useful when determining bottlenecks within a network. It can be used as a measure of the model's performance and for direct comparison with scheme proposals. Modelled and surveyed queues should be compared and presented in accompanying reports. Section [B3.7.2.4](#) contains information on queue length output in Aimsun Next.

3.5.2.6 Public Transport

Similarly to general traffic, modelled public transport journey times should be averaged over multiple seeds and should be within 15% of surveyed on-street journey times. If Public Transport is specified as an output (section [B3.7](#)) then data is automatically collected for each route separately.

3.5.3 Check and Fix

As Aimsun Next generates the model for each Experiment based on the options selected in the Scenario and the Experiment, the Check and Fix tool must be run for every Experiment to identify any errors or inconsistencies in the model that may require attention. The log from a Check and Fix run should be included in the model report and annotated to justify any remaining warnings.

The Microsimulation Network Checker should also be run with a sample Replication for an Experiment to report on any missed turns and lost or stationary vehicles. To activate the Microsimulation Network Checker, select the corresponding box in the Aimsun Next APIs tab of the Dynamic Scenario. This is normally used to detect and remove vehicles which are stopped for a time greater than the Maximum Stationary Time. The Maximum Stationary Time, as well as the action to be taken (delete the vehicle, stop simulation, or write in log) on encountering a stationary vehicle, is defined in the Network Checker editor as shown in [Figure 46](#) below. Ideally, no errors should appear in the Log window during the simulation runs, however, non-critical errors are acceptable within the MAP process (section [B2.1.5](#)).

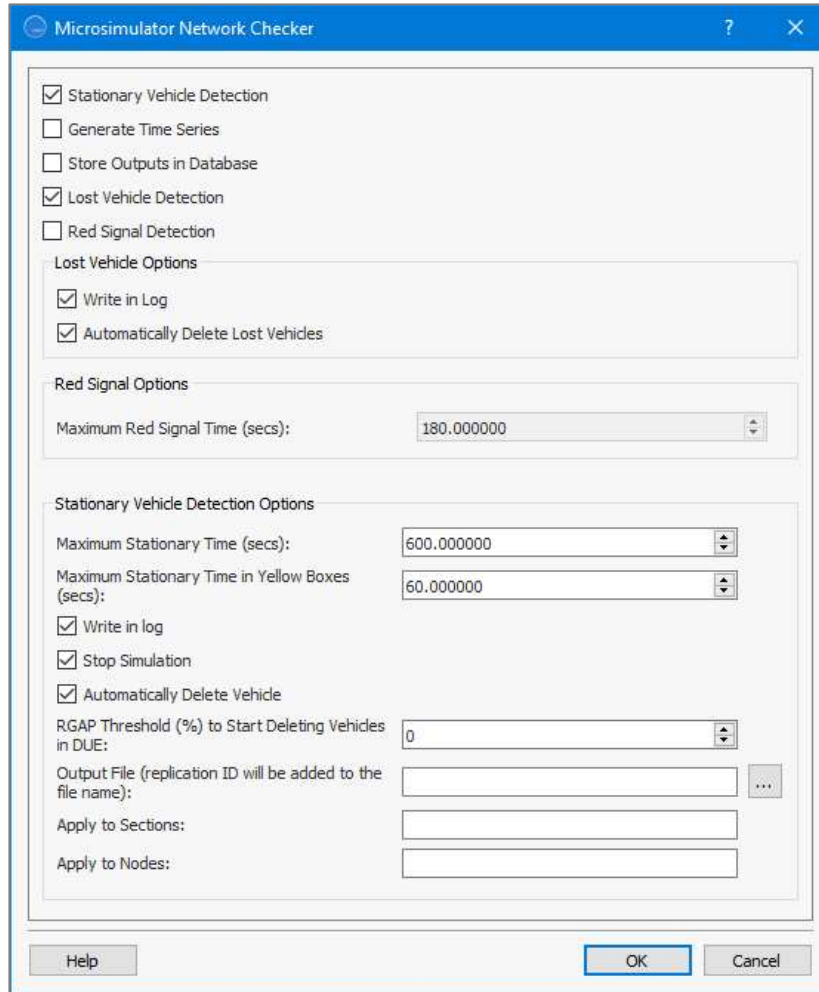

Figure 46: Microsimulator Network Checker window

3.6 Proposed Model Development

It is important that any changes made in a model are both clearly identified and managed to ensure that the multiple different models are consistent and have changes made from the same set of options. For example, NP may opt to test different signal controls and different junction layouts in the context of different levels of demand. Aimsun Next has the ability to create Scenarios and Experiments with different options of network topology, transport demand, signal control and public transport schedules. This provides an efficient method of generating multiple variants of a single model by entering these options once and re-using them in the development option scenarios.

3.6.1 Future Base

The Future Base model bridges the gap between Base and Proposed scenarios and provides a reference when analysing the Proposed results. As described in **B2.5.1**, the Future Base model includes all likely network changes which will occur between the Base year and the year being examined in the proposal, excluding the scheme under consideration. It is built from the Base model by changing as little as possible in relation to each new scheme that has been identified to be added. The guidance in this section applies to creating the Future Base as well as to the Proposed scenarios.

3.6.2 Scenario-Based Workflow

The use of Scenarios and Experiments with reusable components is required when developing option tests in Aimsun Next, to manage the proliferation of model variants and to ensure consistency between them. A typical workflow in option testing is described here:

- I. The calibrated and validated Base model is made available. It will contain:
 - The Base Network;
 - A Traffic Demand composed of either one or more Traffic States or one or more OD Matrices which together represent the current level of traffic demand;
 - A Master Control Plan representing the signal control currently in use;
 - A Public Transport Plan representing the public transport schedules currently in use;
 - A path choice method which may include a set of predefined routes cordoned from a wider area model and used to allocate paths to the strategic traffic passing through the modelled area; and

- If a path assignment is to be used, a Path Assignment Plan.
2. The proposed changes for the option test should be coded in the same model file. These may include:
 - Geometry Configurations representing the proposed changes in road layout;
 - OD Matrices or Traffic States which represent the changes in demand. These are integrated with the existing Traffic States or OD matrices to create new Traffic Demand objects, each with a defined set of demands;
 - At each junction where the signal control is changed, a new Control Plan. The new Control Plans for the altered junctions, and the existing plans for unchanged junctions are integrated into a new Master Control Plan;
 - A set of changed public transport schedules for some or all routes, integrated into a Public Transport Plan;
 - A set of parameter changes in an Attribute Override; and
 - A new Path Assignment Plan if the strategic routes have changed.

The principle underlying these additions is that they are entered once, and reused in the multiple development scenarios

3. A new Aimsun Next Scenario should be created and, under that, one or more Experiments. The objects from the list above are selected in the Scenario with the exception of the Attributes Override, which is selected in the Experiment.
4. The routing is checked for validity:
 - If OD routes, or dynamically created paths are used, no action is required as no path objects were specified in the Scenario;
 - If the Scenario uses paths from a prior static assignment but the strategic road network is unchanged, no action is required;
 - If the Scenario uses paths from a prior DUE or static assignment, and if the future scenario includes changes that alter the network topology, then the APA Fixer should be used to reconnect these paths; or
 - If the Scenario includes paths from a DUE assignment, the paths should be re-evaluated with a new DUE assignment where the warm-up of the new DUE uses the prior DUE paths to evaluate the incremental changes.
5. The Experiment is checked with the Aimsun Next Check and Fix tool and the model Replications for the Experiment are run.

6. Differences between the results from the Base model and the Experiment are displayed in an Aimsun Next View mode, subtracting one from the other. These results are included in the project report.
7. Stages 3 – 6 are repeated with different combinations re-using the model components.

Changes should not be made to the Base model as part of option testing. In all cases it must still be possible to run the Base model from the same Aimsun Next model file, and all the development changes are to be contained in the changed objects which are then included in the development Scenarios and Experiments.

When submitting a model to TfL for audit, the model should only include the final set of data and scenario giving the results presented in the report.

3.7 Model Outputs

Aimsun Next can output data for analysis in a variety of different ways, depending on the type of data and how it will be used.

3.7.1 Methods

The key outputs of microsimulations in Aimsun Next can be accessed using the any of the methods described in this section.

The properties of the statistics to be collected, as well as the time interval for their generation, are specified in the Outputs to Generate tab in the Dynamic Scenario menu (**Figure 47**). The detection interval for gathering detector data is also determined in this tab. All the statistics are disaggregated based on the user classes specified in the model.

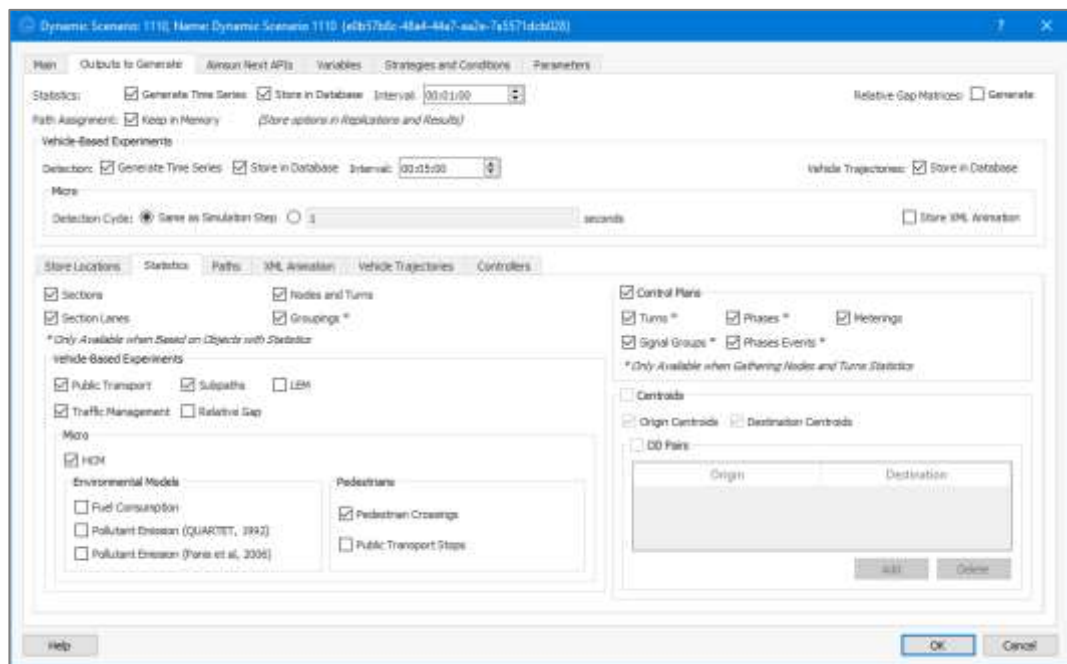

Figure 47: Dynamic Scenario Outputs to Generate tab

In the Statistics sub-tab, the type of outputs required must be specified prior to the simulation. Outputs are provided for the whole network, for Sections, Sections by lane, Nodes and Turns, Subpaths, Groupings and for each public transport line. A full list of statistics which are collected at each level is provided in the Aimsun Next help file⁶⁹. Outputs for signal control can be activated here, including Phase Events which is used for demand dependency validation. Additional microsimulation data such as Highway Capacity Manual (HCM) statistics or the London Emission Module

outputs can be collected during the simulation if they are activated in this tab.

3.7.1.1 Table View

The Table View is available for all network objects. It is possible to specify the type of object to be listed in the table as well as apply filters and conditions to define which specific objects of the selected type will be shown. Using column visibility, the required data can be selected, and the final table can be copied into a spreadsheet. Table View is accessed via Window > Windows > Table View.

3.7.1.2 Time Series

A Time Series can display the values of a variable over time and can be found in the Object Editor menu. It consists of tables and graphs displaying the value of the selected variable of an object during and after the simulation, as shown in **Figure 48**. It can display multiple parameters at a time, including average results from any Replication or Average Replication. Both the tables and graphs from a Time Series can be copied into a spreadsheet.

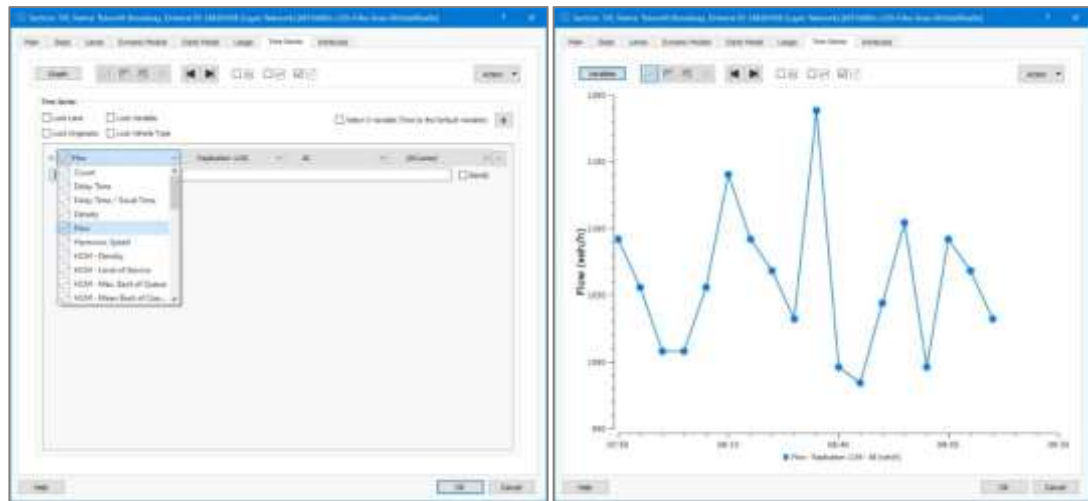

Figure 48: Time Series windows

3.7.1.3 Validation

The Validation tab of a Replication or of a calculated Average can display graphs and tables which show a comparison between the simulated outputs and the corresponding real datasets after the end of a microsimulation. In order to make use of this tool, first a Real Data Set with observed data must be created from the Project menu, via Project > New > Data Analysis > Real Data Set. The observed data from one or more external files can be then loaded into the Real Data Set and the details required to correlate the external files to the Aimsun Next objects and simulated data are specified using the Real Data Simple File Reader Editor (Figure 49).

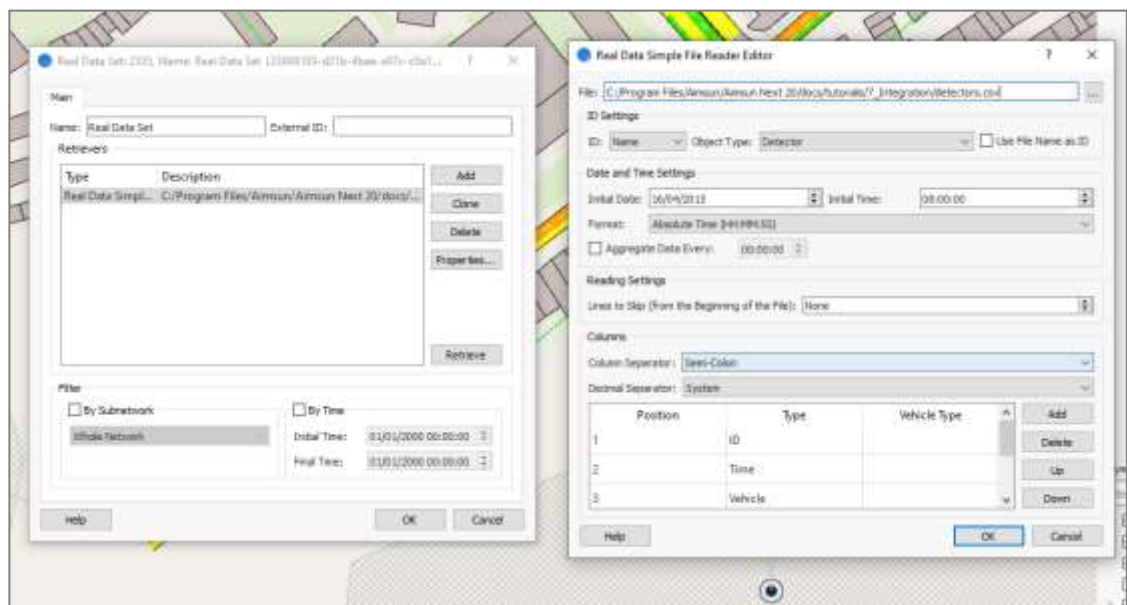

Figure 49: Real Data Set windows

The Real Data Set is selected in the Dynamic Scenario editor and once the microsimulations are complete the Validation outputs can be accessed (Figure 50). These comprise comparison outputs as graphs, linear regression or tables where the key validation criteria such as the GEH statistic can be viewed. All tables and graphs can be exported via the Action > Copy Table Data / Graph option for additional analysis or presentation purposes.

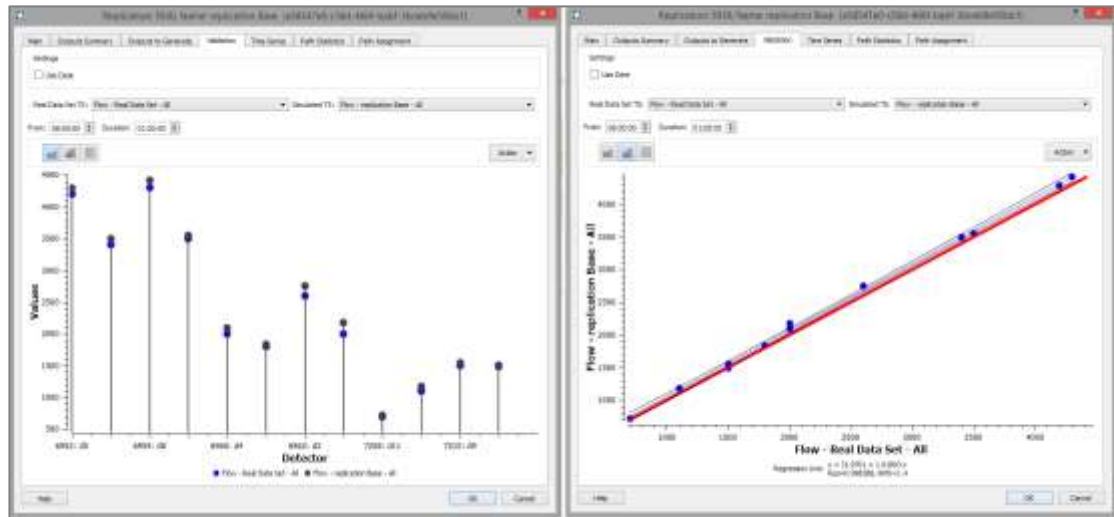

Figure 50: Validation tab of a Replication

3.7.1.4 Database

A database (Access, SQLite or ODBC) with all the simulation information can be generated. The database properties and format are specified using either the Project properties or the Scenario editor menu. Microsimulation outputs are stored in multiple tables and can be extracted by either using a database viewer or by connecting to the database and running SQL queries.

3.7.1.5 Scripting

Aimsun Next scripting, using Python, can be used to automate various tasks including importing and exporting model data. Further information on the key classes and functionalities provided by Aimsun Next can be found in the Aimsun Next scripting documentation, which can be accessed via the Help menu.

3.7.2 Data

While the section above gives general guidance on extracting data from a model, this section provides specific advice on generating the commonly used data outputs.

3.7.2.1 Traffic Flows

The most common ways of collecting traffic flows in specific locations of a model are by using the Time Series data of the corresponding Section or a Detector object. In order to collect the traffic flows of turning movements at key junctions, the use of Subpaths is recommended. Subpaths are defined as a set of consecutive Sections which are connected by Turns, as shown in **Figure 51**. Subpath outputs consist of statistics such as flow, speed, delay time, and travel time, and data is collected only for vehicles that have completed the full length of the Subpath. Therefore, it is recommended that the length of Subpaths used for flow validation is kept as short as possible to guarantee that vehicles can complete their junction turning movement, and so be included in the counts.

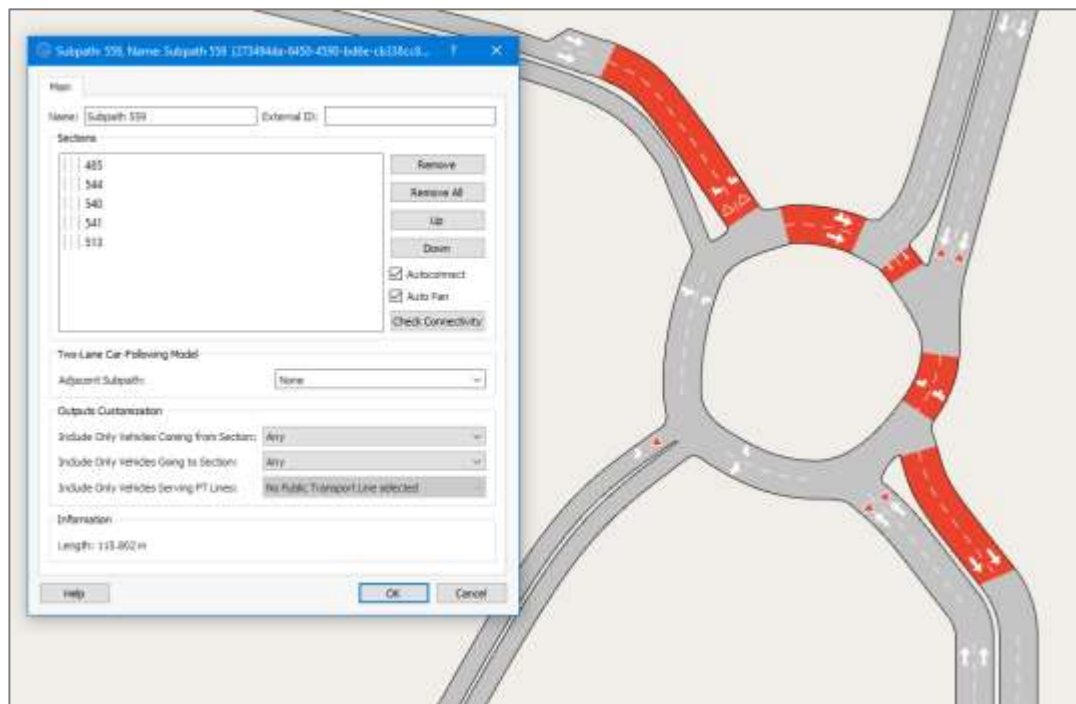

Figure 51: Subpath definition

3.7.2.2 Saturation Flows

By activating the Discharge Rate Evaluation Extension (Micro) extension on the Aimsun Next APIs tab of the Dynamic Scenario menu (**Figure 52**), output text files containing vehicle headways at signalised junctions will be exported to the same location as the model. These outputs can be used to evaluate the saturation flows of signalised junctions. A saturation flow validation spreadsheet can be provided by NP.

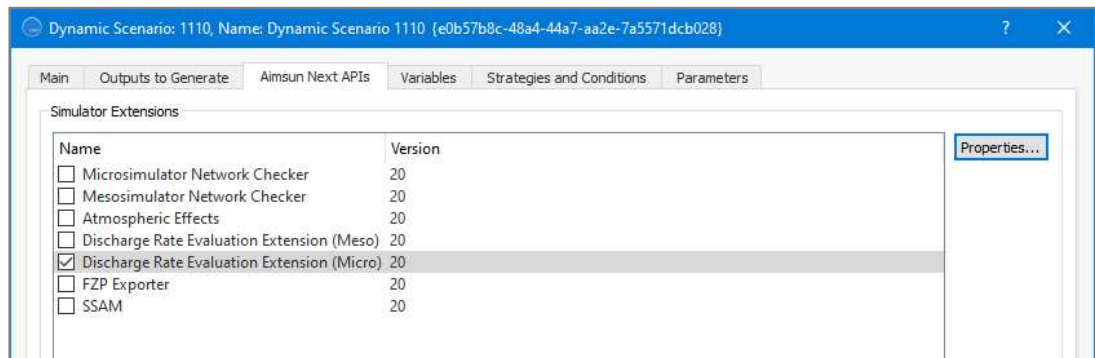

Figure 52: Dynamic Scenario Aimsun Next APIs tab

3.7.2.3 Journey Times

Modelled journey times between two locations can be collected using either Subpaths or Groupings. It is important to highlight that the Subpath statistics will only take into account the journey times of vehicles that have completed the whole length of the Subpath on the specific Sections and Turns which are defined as part of it. In contrast, the journey time of a Grouping will be derived as the sum of the average individual journey times on each Section that is part of the Grouping, vehicles do not have to travel on every Section to be included in the Grouping.

The journey time of the Subpath or Grouping can either be extracted as an average or for each time period and user class using one of the methods outlined in section **B3.7.1**. If Public Transport is specified as an output then data is automatically collected for each route separately.

3.7.2.4 Queue Data

A selection of queuing data, including Mean Queue and Max Queue, is output as part of the general statistics at the various levels of aggregation indicated at the start of section [B3.7](#). The results are given in numbers of vehicles.

3.7.2.5 Signal Timings

Signal Timings are output as part of the Statistics tab and are only available in the database (section [B3.7.1.4](#)). The following outputs are provided at Phase, Turn and Signal levels:

- **State** – the colour that is showing (except at Phase level). See the help file⁷⁰ for the codes associated to each colour;
- **Active Time** – the time in seconds the Phase or state has been active; and
- **Active Time Percentage** – the percentage of the current statistical period that the Phase or state has been active.

Phase Events are also specified here and can be used for demand dependency validation as they detail the time the event was applied and also the reason.

3.7.2.6 Vehicle Trajectory Files

Aimsun Next has the facility to output vehicle trajectory files (*.fzp) for a variety of uses, for example, emissions modelling (see Chapter [C4](#) on [Emissions Modelling](#)), data visualisation and 3D animations. In Aimsun Next, these have a fixed format which consists of simulation time, vehicle information, speed, acceleration and position / orientation data. This is sufficient for emissions modelling and 3D animations, however it limits the data that can be visualised without further processing. The option to activate FZP Exporter is found in the Scenario Editor on the Aimsun Next APIs tab, as shown in [Figure 53](#).

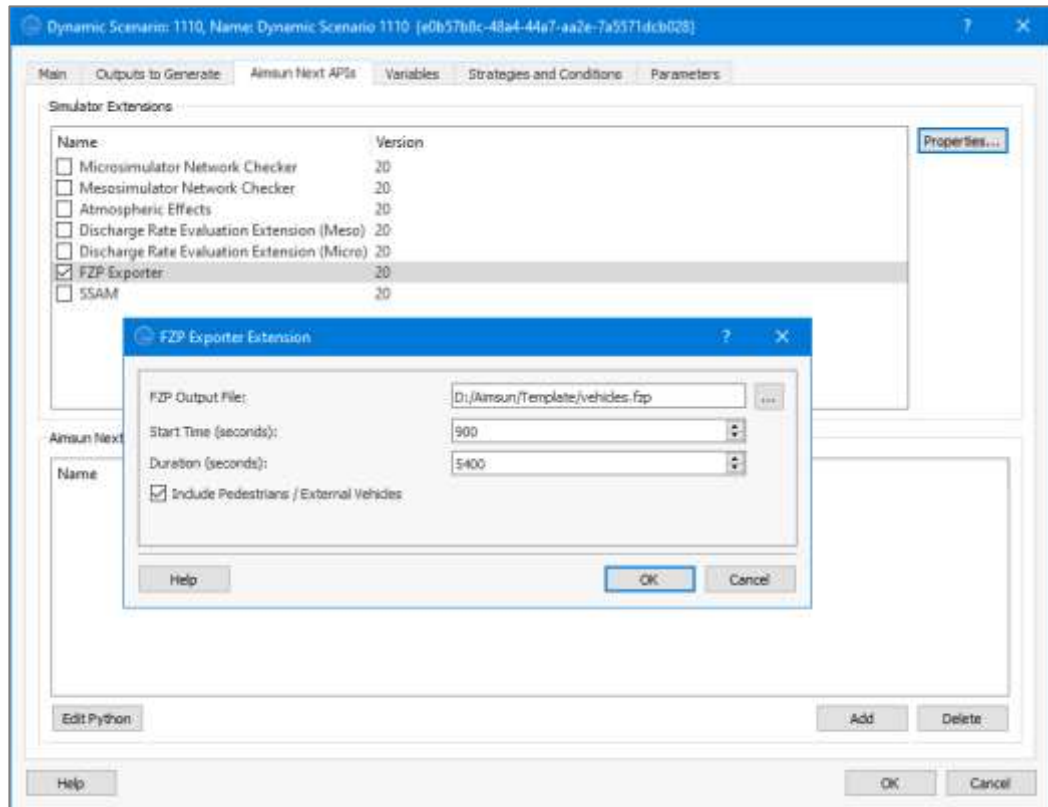
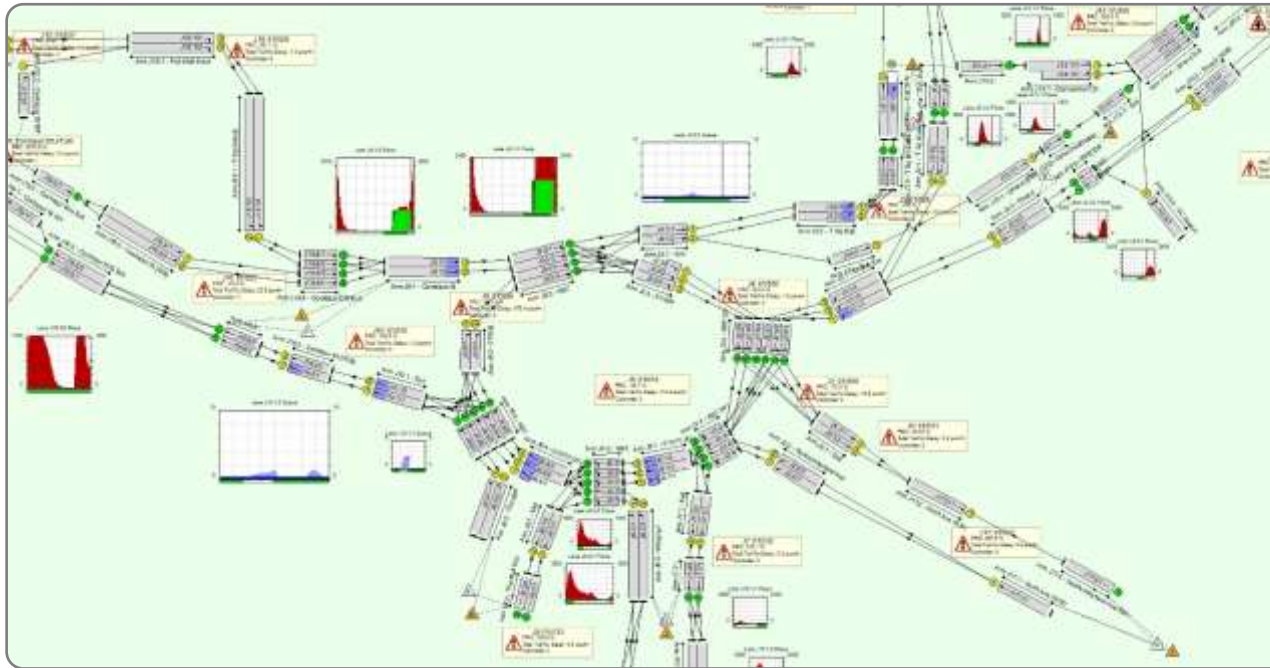

Figure 53: FZP Exporter activation and settings

4 LinSig Modelling



4.1 Introduction

This chapter is designed to assist experienced practitioners when building LinSig models of London's road network. It augments the general modelling guidance given in Chapter **B2** on **Modelling Principles**.

This chapter outlines TfL's recommended approach for modelling with LinSig. However, there will be cases where local conditions or project requirements dictate the use of methods which may be different to those outlined. In these situations, NP should be consulted on the planned methodology where modelling will be submitted for approval by TfL.

4.1.1 Introduction to LinSig

LinSig, developed by JCT Consultancy Ltd (JCT)⁷¹, can be used for detailed junction design, assessment of scheme proposals and the creation of skeleton models for checking against junction Controller Specifications. It combines geometric layout, traffic and controller modelling to ensure that LinSig accurately reflects the way existing junctions work, and how any design proposals would operate if implemented.

In terms of optimisation of junction performance, LinSig allows the efficiency of interstage design to be maximised and is capable of

71 <http://www.jctconsultancy.co.uk>

optimising signal timings to either minimise delay or maximise Practical Reserve Capacity (PRC) at a junction or network level. Signal timings can be manually adjusted by the user to refine the timings or to match site specific safety requirements. Additionally, LinSig has a cycle time optimiser, which allows selection of an optimum cycle time by showing how delay and PRC vary against cycle time increments.

LinSig is used for the design and assessment of isolated signalised junctions, closely associated junctions and the modelling of larger networks using multiple controllers.

4.1.2 Software Versions

LinSig version 3 was released in 2009 and introduced a number of major new features that were not available in previous versions of the software. These changes include:

- **Lane-Based modelling** – previous LinSig versions modelled networks using links, grouping together similar traffic lanes. LinSig 3 uses Lane-Based networks, allowing modelling and data entry for individual Lanes;
- **Multiple controllers** – previous versions of LinSig were restricted to modelling a single signal controller and its associated stage streams. LinSig 3 allows for multiple controllers to be included within a model; and
- **Traffic Flows** – LinSig 3 introduced the capability for Lane-Based flow allocation, while retaining the previous Origin-Destination (OD) Matrix-Based routing method used in previous versions of LinSig.

4.1.3 Appropriate Use of LinSig

This section describes some of the circumstances when it would be most appropriate to develop a LinSig traffic model.

4.1.3.1 Junctions and Networks

LinSig can be used to model isolated signalised junctions or larger networks of signalised junctions.

It is possible to model priority intersections within a LinSig model but this is only appropriate where they form part of a larger network comprised of signalised junctions.

When modelling networks, LinSig is not capable of modelling the causal reasons for poor network performance but can model the effect of exit-blocking upon a junction where input data is manually adjusted (section [B4.5.2](#)). However, under these circumstances, consideration should be

given to using microsimulation modelling, for example, to model both the cause and effect of pan-network exit-blocking.

4.1.3.2 Skeleton Models

LinSig models do not have to include any modelling of traffic flows when used solely for the purpose of assessing the phase-stage relationship at a junction. These skeleton models are effectively a 'control data only' representation of the controller. A LinSig skeleton model can be used to assess phase or stage minimums and interstage durations. Within a skeleton model the stage sequence should be based on current UTC or CLF timing plans, and stage minimums information can be found by reducing LinSig to the minimum allowable cycle time.

Skeleton LinSig models are best suited to augment junction analysis, and are recommended when further modelling will be conducted separately using other modelling software, such as TRANSYT I2, Aimsun Next, Vissim, or Visum. This benefits both modeller and auditor, as it ensures accurate representation of phases, phase minimums, stages, stage sequence, phase delays, intergreens and signal timing plans.

The JCT software package TranEd include tools to convert phase information to links. However, TranEd does not negate the usefulness of LinSig as an auditing tool, for example, LinSig will allow the correct phase-stage representation of parallel stage streams in separate nodes.

4.1.3.3 Pedestrians

LinSig can be used to determine pedestrian journey time and delay values for pedestrian routes across a junction. These values can be determined using either pedestrian count data or nominal pedestrian flows. This information can be used for comparison between Base models and Proposed scenarios. Pedestrian journey time and delay comparisons should only be taken where pedestrian crossings are signalised, as no interaction with traffic is accounted for at uncontrolled crossings.

Where in depth analysis of pedestrian impacts is required, consideration should be given to using specific pedestrian modelling software (see Chapter **C3** on **Pedestrian Modelling**).

4.1.3.4 Proposed Design Changes

LinSig can accurately represent controller behaviour by taking into account the features and constraints of specific controlling equipment. For this reason, LinSig models should be produced to allow auditing of proposed changes to a junction's method of control.

LinSig models are often sufficient to assess local schemes such as carriageway closures, changes to junction methods of control or signal timing revisions. However, LinSig is often unable to provide suitable representation where more complex situations exist such as vehicle merging, junction exit-blocking, traffic reassignment or the dynamic operation of demand-dependent stages. Although some complex situations can be emulated within LinSig use of other modelling software may be more appropriate, such as tactical modelling or microsimulation.

4.2 Preparation

General guidance on Base model development is provided in **B2.4**. This section provides specific guidance for building Base models using LinSig. Model preparation should be discussed at the scoping meeting described in **B2.1.5.1**, and decisions documented within the Modelling Expectations Document (MED) covered in **B2.1.5.2**.

4.2.1 Model Boundary

The applicability of LinSig for modelling multiple junctions should not simply be determined from the physical distance between intersections, but from traffic behaviour between neighbouring junctions. LinSig can produce optimised timings to progress platoons of traffic through a network. Vehicle platooning can be affected not just by distance travelled but also by friction caused by parked cars, road widths, bends or minor sinks / sources. However, the longer the distance between intersections the greater amount of platoon dispersion can be expected, with an associated reduction in the potential benefits to be gained through traffic signal coordination. LinSig is not restricted to a single cycle time within the modelled network, therefore model boundaries are not constrained to a single cycle time or multiples thereof. The junction(s) to be modelled should be discussed and agreed during LMAP Stage I as described in **B2.2.3**.

4.2.2 Data Collection

Prior to building a model in LinSig the following information should already have been obtained, as identified in sections **B2.2** and **B2.3**:

- TfL site numbers and UTC groups to be modelled;
- Site Layout Drawings and SCOOT Link Diagrams (if applicable);
- TfL Controller Specifications and Timing Sheets;
- Site-measured values for link length, flare lengths, cruise time, flare usage and saturation flow. Where measurement has not been possible, estimates should be used with appropriate justification (such as RR67 for saturation flows or extrapolated cruise times if conditions are permanently congested);
- Fully classified stopline traffic flows by turning movement;
- Determination of representative average signal timings, either from the UTC system, site measurement or CLF / FT plans where appropriate (section **B2.3.8**);
- Data on the appearance frequency of any demand-dependent stages; and
- Site observation of traffic behaviour, particularly lane and flare usage.

4.2.3 Model Time Periods

LinSig models typically cover a single hour, which is determined to reflect the peak traffic flow for the period. The Traffic Flows View allows for the manual input of the Flow Group start and end times, and therefore longer peak periods can be modelled if required. General guidance on model time periods is given in section **B2.3.3**.

4.3 Graphical User Interface

A brief overview of the LinSig interface is provided below, describing the main elements of the program window and methods of interaction available. Further detail describing other interface features can be found throughout the remainder of the chapter.

4.3.1 Network Layout View

The Network Layout View displays key elements of the modelled network, including Junctions, Arms and Lanes. These elements can be added by right-clicking in the Network Layout View, and edited or deleted by right-clicking on the modelled element.

This view can additionally be used to graphically display or enter model data, as shown in **Figure 54**, including:

- Input and output data on a Lane and Junction basis;
- Entry and editing of Lane-Based Flows (section **B4.4.6.1**);
- Display of Matrix-Based Flows and their Routes (section **B4.4.6.2**);
- Traffic flow profiles and queue graphs (section **B4.7.2**); and
- Signal timing information, including timing dials and stage diagrams.

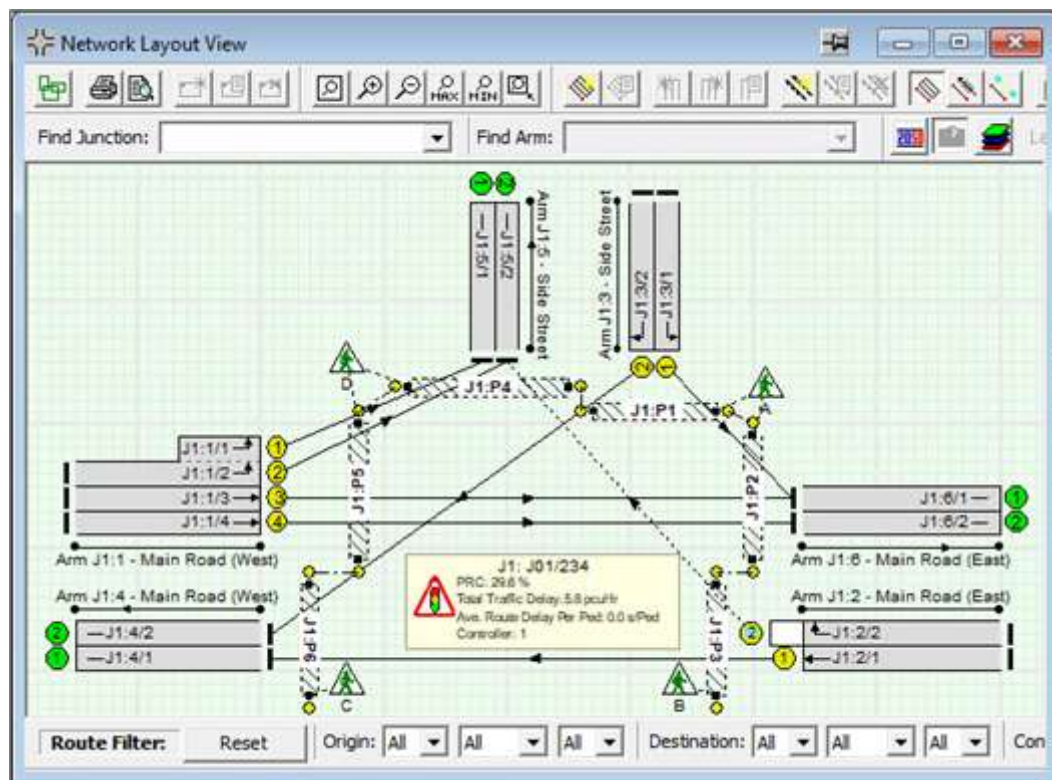

Figure 54: LinSig Network Layout View

It is also possible to add notes and labels to the Network Layout View which can be used to reflect key model assumptions or auditing notes.

4.3.2 Error View

The LinSig Error View identifies warnings and errors within the model. The presence of warnings or errors is highlighted at the bottom of the main LinSig window and further detail is given in the Error View window, as shown in

Figure 55. Warnings identify where items might need to be checked and errors prevent the model from running.

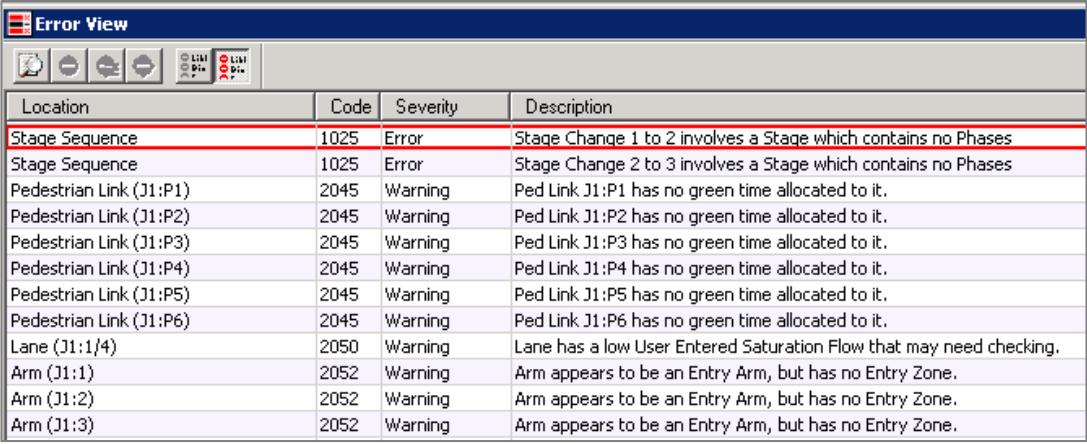

Location	Code	Severity	Description
Stage Sequence	1025	Error	Stage Change 1 to 2 involves a Stage which contains no Phases
Stage Sequence	1025	Error	Stage Change 2 to 3 involves a Stage which contains no Phases
Pedestrian Link (J1:P1)	2045	Warning	Ped Link J1:P1 has no green time allocated to it.
Pedestrian Link (J1:P2)	2045	Warning	Ped Link J1:P2 has no green time allocated to it.
Pedestrian Link (J1:P3)	2045	Warning	Ped Link J1:P3 has no green time allocated to it.
Pedestrian Link (J1:P4)	2045	Warning	Ped Link J1:P4 has no green time allocated to it.
Pedestrian Link (J1:P5)	2045	Warning	Ped Link J1:P5 has no green time allocated to it.
Pedestrian Link (J1:P6)	2045	Warning	Ped Link J1:P6 has no green time allocated to it.
Lane (J1:1/4)	2050	Warning	Lane has a low User Entered Saturation Flow that may need checking.
Arm (J1:1)	2052	Warning	Arm appears to be an Entry Arm, but has no Entry Zone.
Arm (J1:2)	2052	Warning	Arm appears to be an Entry Arm, but has no Entry Zone.
Arm (J1:3)	2052	Warning	Arm appears to be an Entry Arm, but has no Entry Zone.

Figure 55: LinSig Error View

The Error View is a useful tool for identifying potential errors within a network, however it does not remove the need for manual checking and auditing of a model.

4.3.3 Scenarios

Scenarios enable different situations to be modelled within a single LinSig model file, which can be useful when modelling different time periods or assessing different signal strategies.

All information required for an individual LinSig model run is grouped within a Scenario. The information required for a Scenario includes:

- The traffic Flow Group to be modelled;
- Route assignment options for Matrix-Based Flow allocation;
- The Network Control Plan, detailing the signal plans for all modelled junctions;
- Cycle time; and
- Stage timings.

The information on all scenarios within a LinSig model file are shown in the Scenarios View window, as shown in **Figure 56**.

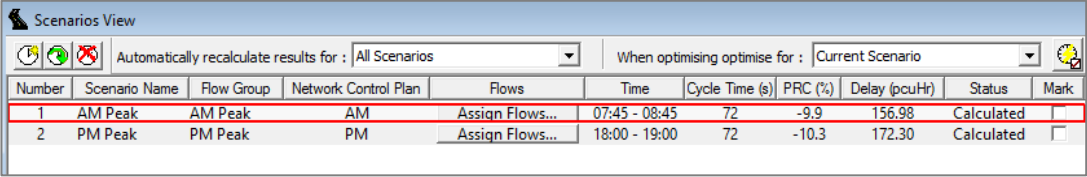

Number	Scenario Name	Flow Group	Network Control Plan	Flows	Time	Cycle Time (s)	PRC (%)	Delay (pcuHr)	Status	Mark
1	AM Peak	AM Peak	AM	Assign Flows...	07:45 - 08:45	72	-9.9	156.98	Calculated	<input type="checkbox"/>
2	PM Peak	PM Peak	PM	Assign Flows...	18:00 - 19:00	72	-10.3	172.30	Calculated	<input type="checkbox"/>

Figure 56: LinSig Scenarios View

4.3.4 Controller Selection

Several windows can be displayed in LinSig to show controller data items, including:

- Phase View;
- Intergreen View;
- Stage View;
- Stage Sequence View;
- Signal Timings View; and
- Interstage and Phase Delay View.

By default, these display controller information for the currently selected controller, as chosen from the Controller drop-down box in the LinSig program toolbar.

It is additionally possible to open multiple instances of these windows within a multiple-controller LinSig model, allowing for comparisons to be made between different controllers. To do this a separate drop-down box

is available within each window, allowing the controller to be separately locked for that window to a different controller than the currently selected controller, as shown in **Figure 57**.

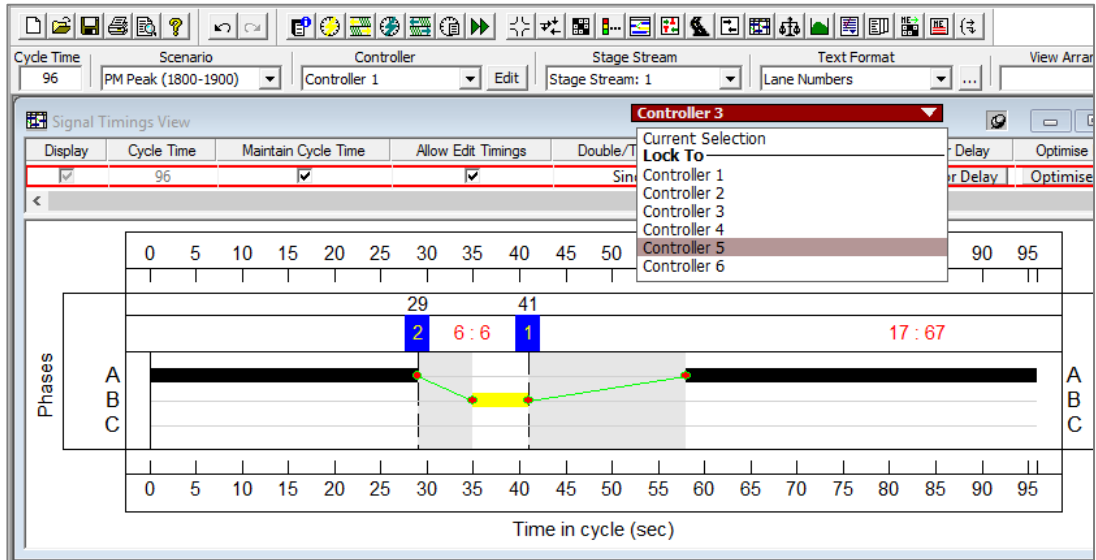

Figure 57: Controller selection within LinSig Controller Data Windows

4.4 Base Model Calibration

Once input data has been collected, the model can be built and calibrated. This section provides guidance on the structure of data in LinSig and how to approach the model build.

4.4.1 Calibrated Model

A calibrated LinSig Base model is defined as being a model which has the appropriate network structure, geometric measurements and signal timing data for the period being modelled and is submitted during LMAP Stage 2, as described in **B2.1.5**. It should contain representative signal timings with no demand-dependent stage adjustments, and should be accompanied with a technical note as detailed in section **B2.6.1**. This should state the purpose of the model, the period being modelled, the LinSig software version used and the details of the study area.

The purpose of the calibrated model is to allow the developer and any model auditor to assess the model structure and arrangement. At this stage it may be possible to identify issues relating to the development of the model and address them at an early opportunity. A copy of the calibrated model should be kept on file for future reference.

4.4.2 Network Settings

The 'Network Settings' within LinSig details the default parameters that are to be used relating to the traffic model, traffic flow assignment and controller. It is recommended that the default values are maintained unless there is a specific reason to change them. Any amendments should be detailed and justified in supporting documentation.

The 'Network Information' section should be completed to aid model auditing by including the location of the junction(s), the purpose of the model and the information sources used to build the model. Useful information could include:

- TfL site reference(s);
- Scheme title;
- Location (such as the identification of intersecting roads);
- Time period being modelled; and
- Whether the model is a Base or Proposed model.

4.4.3 Network Structure

The road network is represented in LinSig as a collection of interconnected Junctions, Arms and Lanes. Creating a suitable Lane structure is one of the most important aspects of building a LinSig model, as it determines how traffic behaviour will be replicated in the final model.

A diagram showing an example junction in LinSig's Network Layout View is shown in **Figure 58**.

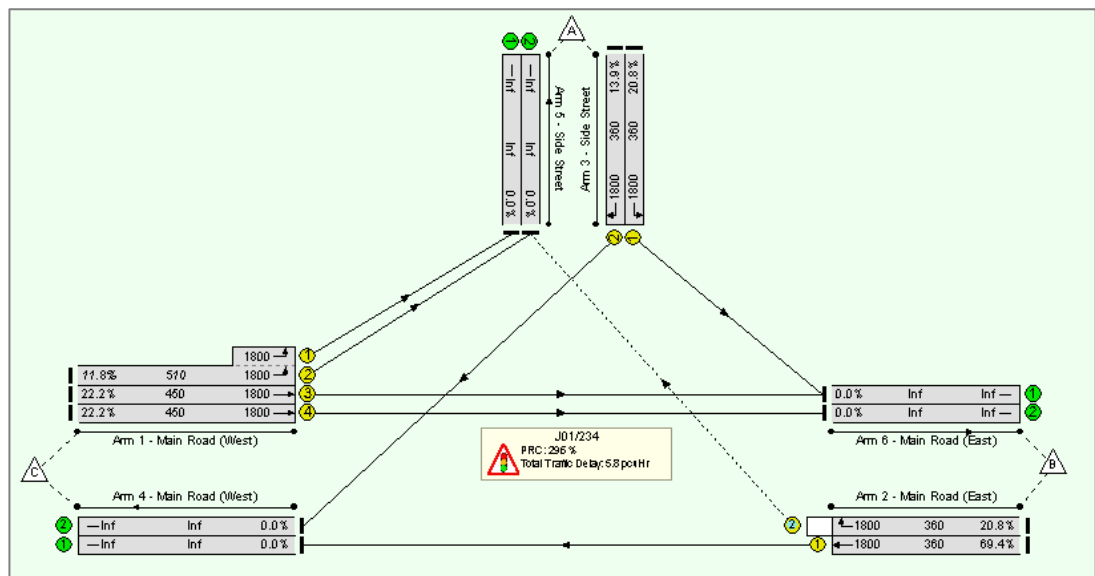

Figure 58: Example junction showing Arms, Lanes, Connectors and Zones in LinSig

4.4.3.1 Junctions

Junctions group all the individual items that represent a junction on street, such as Arms and Lanes, and allow manipulation, optimisation and performance reporting for individual junctions. A Junction can be defined as being signalised or priority-controlled and, if appropriate, the corresponding controller(s) can be allocated. Junctions should also be labelled to describe what they are intended to represent, for example using a junction or stream site reference number.

4.4.3.2 Arms and Lanes

An Arm represents a one-way section of road within the modelled network, which should therefore contain at least one Lane. Arms allow individual groups of Lanes to be graphically manipulated as a single entity. It is important from an auditing point of view that each approach Arm is correctly labelled with the relevant street name (or similar) as the Lane numbering system within LinSig is arbitrary.

Each lane that exists, or is seen to function as a separate lane during on-street observation, must be modelled as a separate Lane within LinSig. A Lane is defined as either long or short. A Long Lane extends sufficiently far back towards the upstream junction that it always behaves as a dedicated lane over the available green time, whereas a Short Lane represents a flare, only contributing as a full lane for a portion of the available green time.

LinSig allows for adjacent Lanes exhibiting identical behaviour in terms of queuing, traffic distribution and signal control to be grouped within Multi-Lanes. These are defined by the number of Lanes and whether the Multi-Lane includes a flared approach. Multi-Lanes can be used to simplify the modelled network, as long as the use is appropriate and the above conditions are met.

4.4.3.3 Connectors

Connectors link the exit point of one Lane to the entry point of another Lane, and define the turning movements permitted from each Lane. In larger networks a chain of successive Lanes and Connectors can be used to define the routes traffic can take through a network. Any Lane within the LinSig model that does not have a Connector leaving the Lane will be treated as an exit Lane.

4.4.3.4 Zones

In LinSig, Zones can be used to define the entry and exit points to the modelled network. These form the basis for routing traffic through the network when using Matrix-Based Flows (section [B4.4.6.2](#)) and can be used for Route-Based performance analysis. They can also be useful when using Lane-Based Flows (covered in [B4.4.6.1](#)), such as for bus route calibration or performance analysis for lane sequences along a route.

4.4.3.5 Flared Approaches

Flared approaches are represented in LinSig as short Lanes, which must be grouped with at least one adjacent Long Lane that it will interact with, forming a Lane Group. The physical length of a flare should be included for all Short Lanes, reflecting the number of PCUs that can be stored within the flare when fully occupied.

Flare usage is automatically calculated from the physical length and the impact of blocking by traffic in adjacent Lanes. However, it is possible to override the amount of traffic using the flare by setting custom occupancies to be used instead of the physical length. Custom occupancies can be set at a single value for all modelled Scenarios, or adjusted for individual Scenarios as required and monitored using flare storage graphs (section [B4.7.2](#)). The use of custom occupancies should be reported and justified in supporting documentation and be calibrated based on site-collected measurements. It is important to note that custom occupancies used in LinSig 3 are not the same as effective flare lengths that were previously used in LinSig 2.

The Lane-Based modelling approach used in LinSig allows for separate Lane control and signal phasing for Long and Short Lanes. The performance of a Lane Group can be reported as a single combined value or as separate figures for each Long and Short Lane, as shown in [Figure 59](#). This feature can be selected and amended via the Network Settings menu.

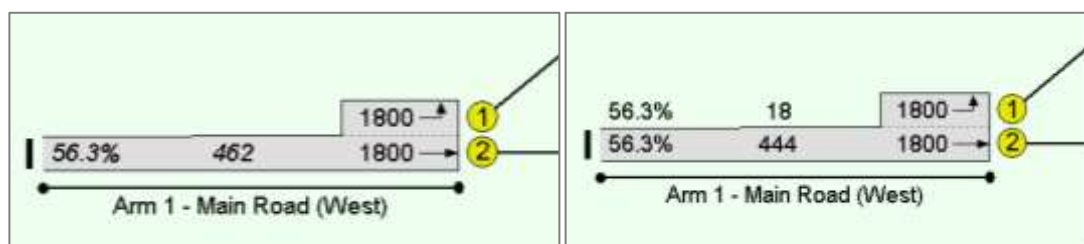

Figure 59: Combined (left) and separate (right) capacity results for Short Lanes



In LinSig a Long Lane can only have one associated Short Lane, therefore assumptions may be required to reflect situations where multiple flares are fed by a single Long Lane.

In certain scenarios it may be necessary to model flared approaches using the Multi-Lane representation. This method does not consider the blocking impacts of adjacent traffic Lanes and therefore the use of Short Lanes is preferred where significant blocking effects may occur.

4.4.3.6 Classification of Lanes

Lane control can be classified into four groups determined by how the lane operates on street and are indicated by different coloured circles at the start of the Lane in the Network Layout View, as shown in **Table 9**.

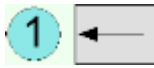
Table 9: Lane control types in LinSig

Lane Control Type	Description	Network Layout View
Fully signalised Lanes	Controlled by one or more traffic phase, which do not give way to other movements	
Unsignalised priority-controlled Lanes	Controlled by giving way to an opposing traffic flow, such as minor arms at priority junctions or left turn slips	
Combined signal and priority-controlled Lanes	Controlled by a traffic phase and also giving way to an opposing traffic movement, such as opposed right turning movements at signalised junctions	
Free-flowing Lanes	Commonly used to reflect mid link bottlenecks and exit links. Where used as bottleneck Lanes, these could reflect where traffic flow is limited between junctions, such as carriageway narrowing and carriageway fanning	

Internal junction Exit Arms can be included where multiple junctions are included in a model. Exit Arms act to collect traffic leaving a junction prior to the modelling of the approach Lanes to the subsequent junction (**Figure 60**). When used the Exit Arms should have a short Lane length, such as the distance from the stopline to the junction exit, with the length between junctions applied to the approach Lanes of the downstream junction. The

Connector cruise times should appropriately reflect the Lane lengths used. Exit Arms can be used to allow lane changing and weaving between two junctions.

Pedestrian Links can be added to a junction to represent where pedestrian crossing facilities are provided. The modelling of pedestrian crossings in LinSig is detailed in section [B4.4.8](#).

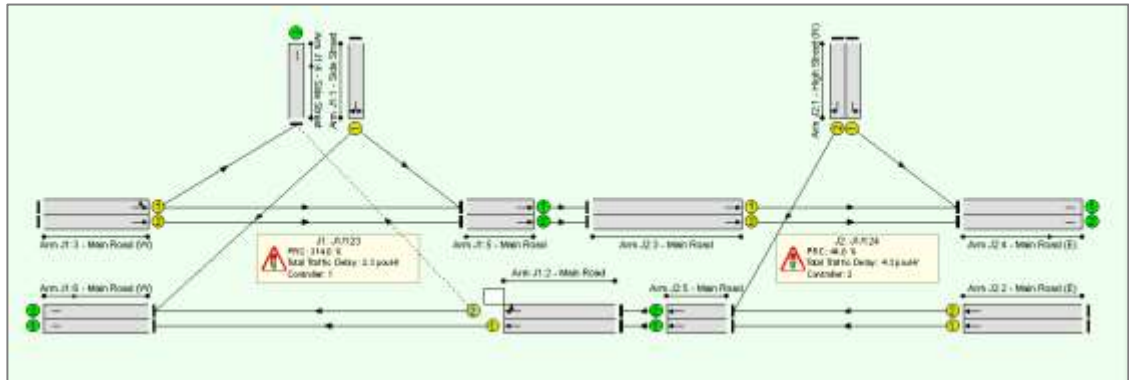

Figure 60: Example of junction Exit Arms being used between two junctions in LinSig

4.4.3.7 Saturation Flows

Saturation flows should be measured on street for all critical Lanes, as described in [B2.3.9](#). Saturation flows should be directly entered for each Lane included in the LinSig model. Where on-site measurement is not possible, RR67 values (described in [B2.3.9.1](#)) can be calculated manually and directly entered into the model or, alternatively, geometric parameters can be entered into LinSig (lane width, gradient and turning radius) from which RR67 values will be calculated automatically. Saturation flows calculated from RR67 should be used with caution, and the suitability of the calculated saturation flow values for the modelled area should be assessed as described in [B2.3.9.1](#).

If saturation flows are directly specified for Exit Lanes they should be suitably high (for example 8000PCU/hr) so that artificial and unintended queuing does not occur on the exit of the network, which may be the case if default values are used or if the Exit Arm contains an insufficient number of Lanes. A recommended alternative is to specify all Exit Lanes as being ‘unconstrained (infinite saturation flow)’ to ensure traffic will incur zero delay when exiting the model. A similar approach should be used when Exit Arms are used between junctions. Where queuing is observed on a

downstream exit from a modelled junction then the modelling approach and use of LinSig should be re-assessed.

Saturation flows are required for each Lane or identically performing group of Lanes within the model.

4.4.4 Signal Control

This section covers the implementation of Controller-Based signal timings within a LinSig model, detailing key areas where signal information is entered. It is important to ensure that phase-based signal controller behaviour is accurately modelled.

4.4.4.1 Controller Sets

It is possible to model different cycle times within a single LinSig model. This can be achieved by creating Controller Sets and assigning individual controllers to these sets. The cycle time for each Controller Set can be edited accordingly, although it is also possible to double-cycle or triple-cycle a controller within a single controller set. For advice on how to determine whether the model should include junctions operating at different cycle times, refer to section [B4.2.1](#).

Cycle times can be amended in the Scenario View (see [B4.3.3](#)), main tool bar (see [B4.3.4](#)) or within the Controller List View, as shown in [Figure 61](#).

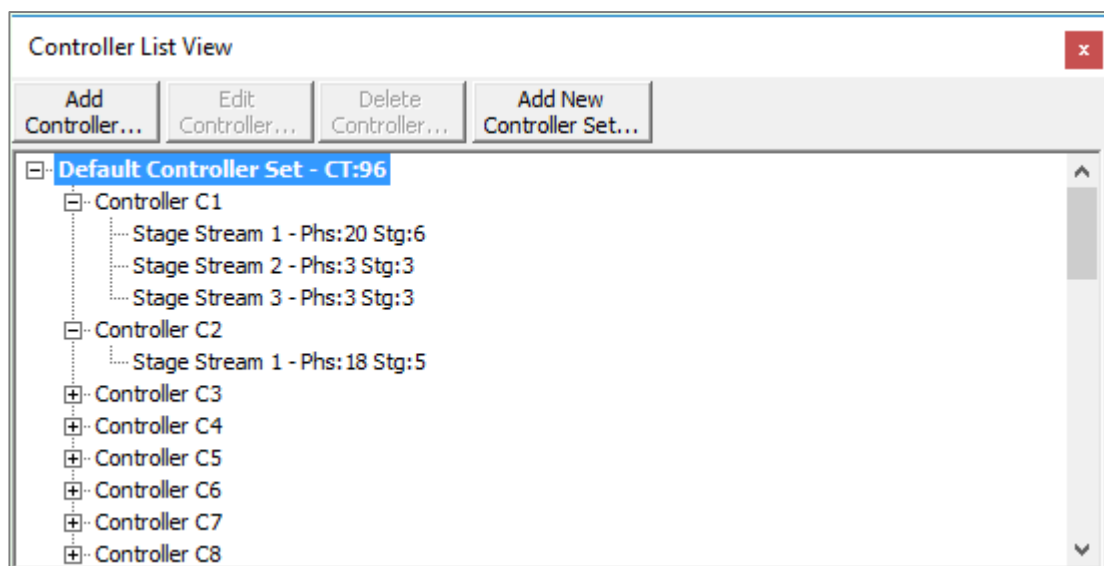

Figure 61: Controller List View, showing Controller Sets and cycle times

4.4.4.2 Controller Input Data

The following information needs to be included for each controller:

- Controller Type;
- Phase Data (including Phase Type, Controller Minimum and Associated Phases);
- Phase Intergreens;
- Stages (defining the Phases within the Stage and the minimum stage time);
- Interstages, Prohibited Stage Moves and Phase Delays (detailing the interstage length, prohibited stage moves and a list of Phase Delays); and
- Stage Sequence.

For an existing junction, the controller type should reflect the manufacturer of the hardware that is on street, as identified in the Controller Specification and/or Timing Sheet.

It is important that the correct controller type / manufacturer is selected as this determines how gaining phase delay values are interpreted and specifying the wrong manufacturer could result in the modelling of incorrect signal timings. Particular care therefore needs to be taken when modelling phase gaining phase delays to ensure they are appropriately represented, as highlighted in **B2.3.8.1**.

For models submitted to TfL it is required that the source of the controller data used to build the model is specified (evidenced by the Timing Sheet issue number and/or Controller Specification issue number).

LinSig can model two types of phase minimums, street phase minimums and controller phase minimums. Street phase minimums are the minimum time a phase must appear on street and includes any time provided by phase losing delays. Controller phase minimums are the minimums entered into the controller, which is the time the phase has to receive green irrespective of any additional green time provided by a phase losing phase delay.

It is important that when modelling existing junctions that the phase minimum type is set to 'controller phase minimums' and not 'street phase minimums'.

4.4.4.3 Stage Sequences and Network Control Plan

The Stage Sequence View lists the different stage orders that can be run by a controller. The Stage Sequence may vary between modelled time periods or in different traffic conditions.

A Network Control Plan is also required and states which stage sequence is used by each controller for each modelled Scenario, as shown in [Figure 62](#).

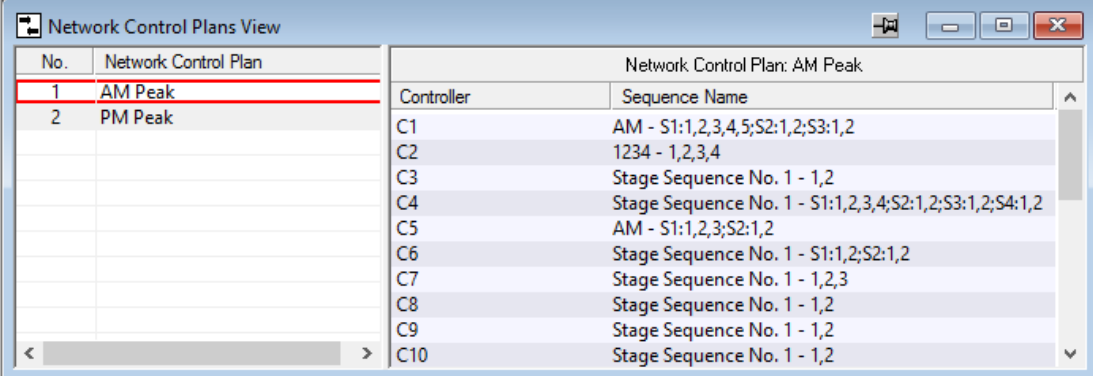

No.	Network Control Plan	Network Control Plan: AM Peak	
		Controller	Sequence Name
1	AM Peak	C1	AM - S1:1,2,3,4,5;S2:1,2;S3:1,2
2	PM Peak	C2	1234 - 1,2,3,4
		C3	Stage Sequence No. 1 - 1,2
		C4	Stage Sequence No. 1 - S1:1,2,3,4;S2:1,2;S3:1,2;S4:1,2
		C5	AM - S1:1,2,3;S2:1,2
		C6	Stage Sequence No. 1 - S1:1,2;S2:1,2
		C7	Stage Sequence No. 1 - 1,2,3
		C8	Stage Sequence No. 1 - 1,2
		C9	Stage Sequence No. 1 - 1,2
		C10	Stage Sequence No. 1 - 1,2

Figure 62: LinSig Network Control Plans View window

4.4.4.4 Signal Timings View

Stage and phase timings can be interactively edited using the Signal Timings View, as shown in [Figure 63](#). Alternatively, signal timings can be adjusted via Timing Dials in the Network Layout View.

The information contained within the Signal Timings View includes:

- Stage timings, including stage and interstage lengths;
- Phase timings;
- Interstage details, including phase delays and intergreens; and
- Whether the controller single-cycles, double-cycles or triple-cycles within the controller set's cycle time.

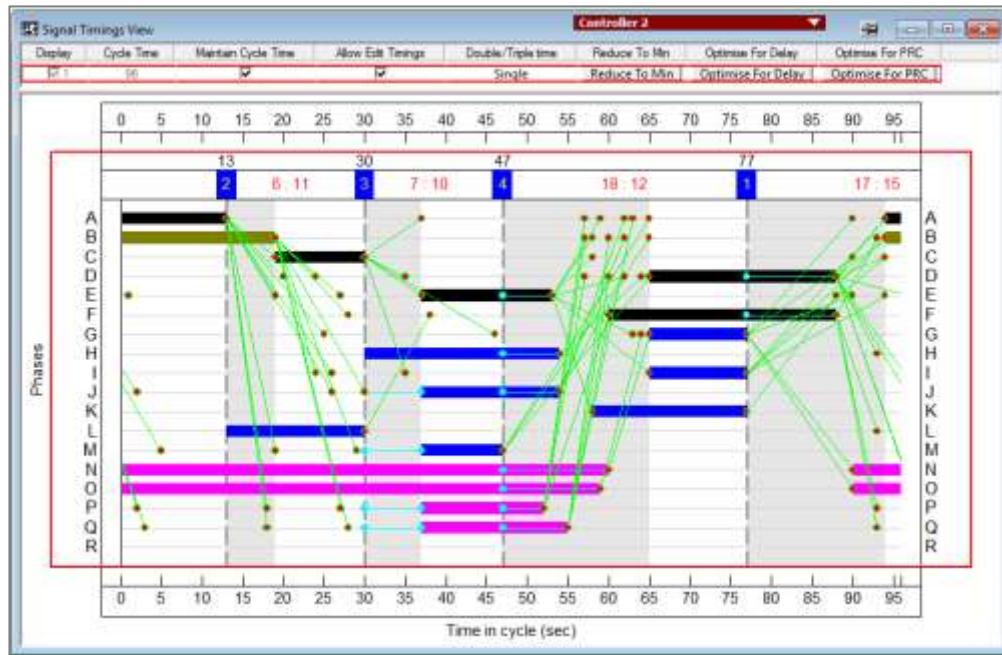

Figure 63: LinSig Signal Timings View window

The controller's signal timings can also be optimised within this view. Refer to section [B4.6.4.1](#) for further information.

4.4.5 Priority Control

Opposed movements within LinSig can be separately classified as either priority-controlled movements or movements that are both priority and signal-controlled. These priority-controlled elements are represented by different Lane types, as detailed in section [B4.4.3.6](#). The parameters required to accurately model priority control within LinSig are detailed in the following sections.

4.4.5.1 Give-Way Parameters

For priority movements that give way, the LinSig model requires the entry of these essential parameters:

- 'Maximum Flow while Giving Way', which describes the maximum flow rate of traffic in the absence of an opposing flow, but while still giving way to the opposing movement. This is often called the intercept, as it represents the intercept with the Y axis when the flow giving way (Y axis) is plotted against the opposing flow (X axis). It is measured in PCU/hr;
- Minimum flow, which represents the minimum amount of flow, in PCU/hr, that can discharge regardless of the level of opposing flow. This parameter should only be used if it is deemed LinSig is underestimating the discharge under high levels of opposed flow. The

use of the Minimum flow parameter should be clearly documented in accompanying reports;

- Details of the opposing Lane and turning movements;
- Clear Conflict time, which details the time for vehicles in the opposing movement to travel from the stopline to the conflict point; and
- Give-way coefficient, which describes the assumed linear gradient (the 'slope') specifying how the flow giving way decreases as the opposing flow increases.

JCT recommends the use of typical give-way parameters for different types of opposed movements as a starting point⁷², such as an intercept of 1439PCU/hr and slope of 1.09 for opposed right-turns at signalised junctions and an intercept of 715PCU/hr and slope of 0.22 for give-way-controlled left-turns. These are typical parameters, however it may be appropriate to use more accurately estimated or measured give-way parameters for critical priority movements. This could be achieved by:

- Use of PICADY to estimate give-way parameters at priority junctions;
- Use of ARCADY to estimate give-way parameters at priority roundabouts; or
- Measured on-site data, plotting various opposing and opposed flow rates from which the intercept and slope can be measured.

4.4.5.2 Opposed Right-Turn Parameters

The ability to accurately model opposed right-turning vehicles at traffic signals requires careful site observation and entry of LinSig parameters. Particular attention should be paid to recording and calibrating:

- Storage in front of the stopline;
- Non-blocking storage;
- Maximum number of turners in intergreen (which may be less than the storage in front of the stopline);
- Clear conflict time;
- Right turn move up; and
- Right-turn factor.

The clear conflict time determines how long vehicles giving way have to wait for opposing traffic to travel from the stopline to the conflict point before the opposed traffic can proceed to clear during the intergreen period. This may be of higher importance in larger junctions where

opposing traffic have longer distances to travel before reaching the conflict point.

The right-turn factor controls the amount of bonus capacity available due to storage in front of the stopline. Its default value is 0.5 and should not be changed unless supported by site observation. Any amendment should be reported and justified based on site-collected data.

For opposed right-turns which are subsequently unopposed (for example indicative arrows), it is imperative to set the 'Flow when opposing traffic is stopped' to the appropriate link saturation flow. This can be important where a Lane contains a mixture of opposed and unopposed movements that can lead to the obstruction of unopposed movements. For right-turns which remain opposed at all times, this should be set to the maximum flow while giving way (as entered in the give-way parameters).

4.4.6 Traffic Flows and Flow Allocation

Traffic flow data for LinSig models should be based on fully classified turning count data and converted to equivalent PCU values, as described in section [B2.3.4.1.1](#).

Traffic flows can be entered into a LinSig model using two different methods:

- Lane-Based flow allocation; and
- Matrix-Based flow allocation.

These methods are described in more detail in the following sections. Both methods use Flow Groups, which require start and end times for each period being modelled to be entered. Flow Groups can be specified as either independent from other Flow Groups (a Standard LinSig Flow Group), or mathematically derived from one or more other Flow Groups (a Formula Flow Group), as illustrated in [Figure 64](#).

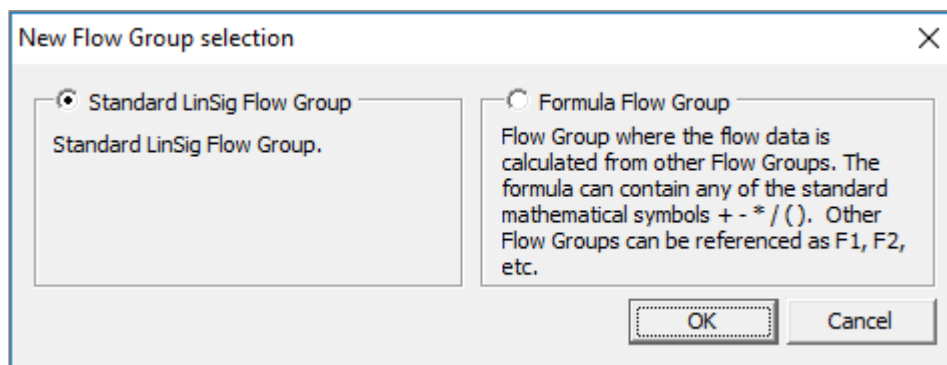

Figure 64: Flow Group definition in LinSig

4.4.6.1 Lane-Based Flows

Lane-Based flows are directly entered onto Lanes and Connectors to reflect the total stopline flow for the Lane and for incoming / outgoing turning movements. They can be separated by traffic mode, or other groups of interest, as shown in **Figure 65**. With Lane-Based flows no routing information through a junction or a network is required.

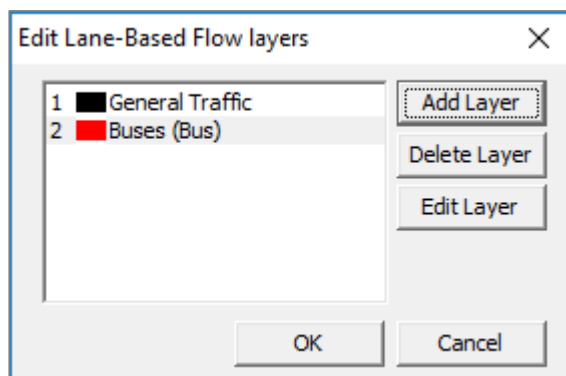

Figure 65: Lane-Based Flow Layers dialog box

The flows are defined in PCUs and can be edited via the Lane-Based Flow Entry Mode (**Figure 66**) or using the Lane-Based Flow Layer tab in the 'Edit Lane View' (**Figure 67**).

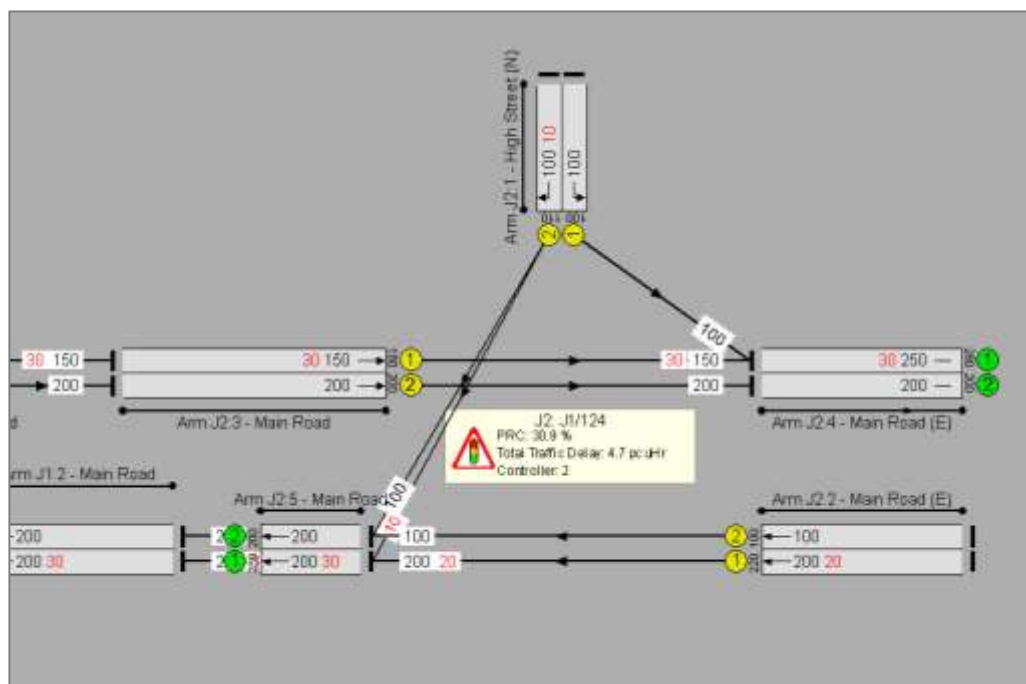

Figure 66: Lane-Based Flow Entry Mode, showing different Flow Layers in different colours

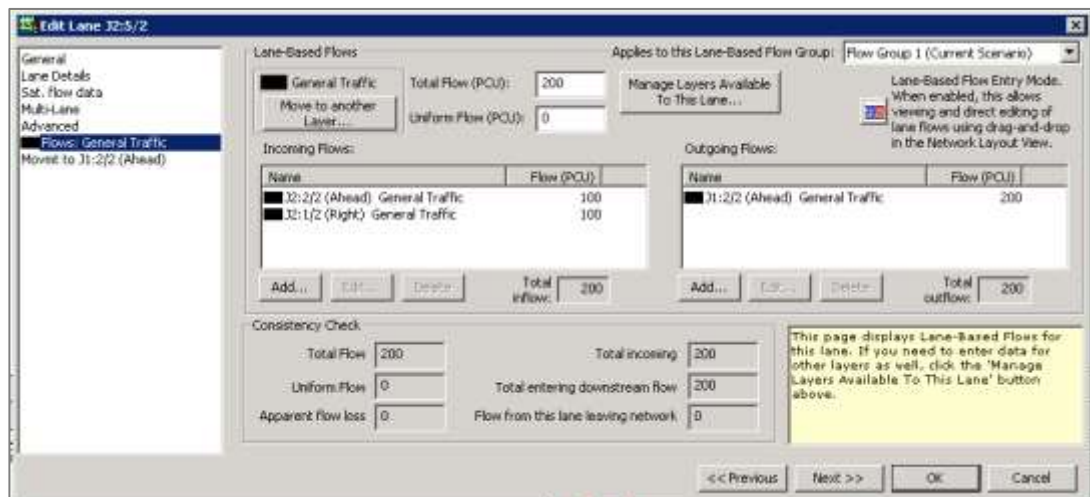

Figure 67: Lane-Based Flow Layer editing in the Edit Lane View

Where multiple junctions are being modelled, checks should be carried out to ensure that turning count data is consistent between adjacent sites, as described in **B2.3.4.1**. The Flow Consistency Mode can be used to visually highlight locations where flow inconsistencies occur, as seen in **Figure 68**, where the size of the blue circle varies depending on the size of the discrepancy. Where multiple Lanes feed a downstream Lane, or where a single upstream Lane feeds multiple downstream Lanes, the split between origin and destination Lanes should be observed and recorded.

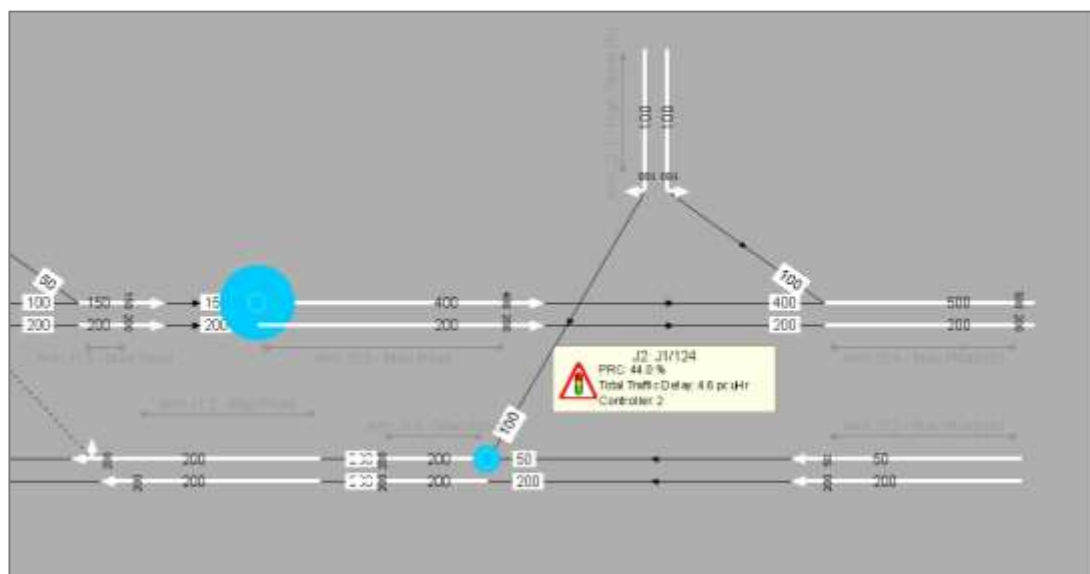

Figure 68: Flow Consistency Mode, with flow inconsistencies highlighted in blue

It is recommended that a different flow layer is used to separate public transport from general traffic. When creating a separate Flow Layer for

public transport, it is important that the 'This layer models buses' box is ticked to allow for bus cruise speeds and the impact of bus stops. Where multiple Flow Layers have been created, the Lanes in the network need to reflect which Flow Layer can use them using the 'Manage Layers Available to this Lane' function.

If considered necessary, it is possible to use custom cruise times for specific Flow Groups, Flow Layers or Routes, which override the default Connector cruise times. Any overrides to Connector cruise times should be recorded and justified.

Where a network-wide OD survey isn't available, Lane-Based Flow groups are the preferred method for inputting flows, giving full control over allocation of flow layers to traffic Lanes.

4.4.6.2 Matrix-Based Flows

Traffic flows can be assigned to routes using a Zone-Based OD matrix, with individual entry and exit Arms allocated to different Zones, as shown in **Figure 69**. Dedicated bus-only Zones can also be specified to define bus routes through the network.

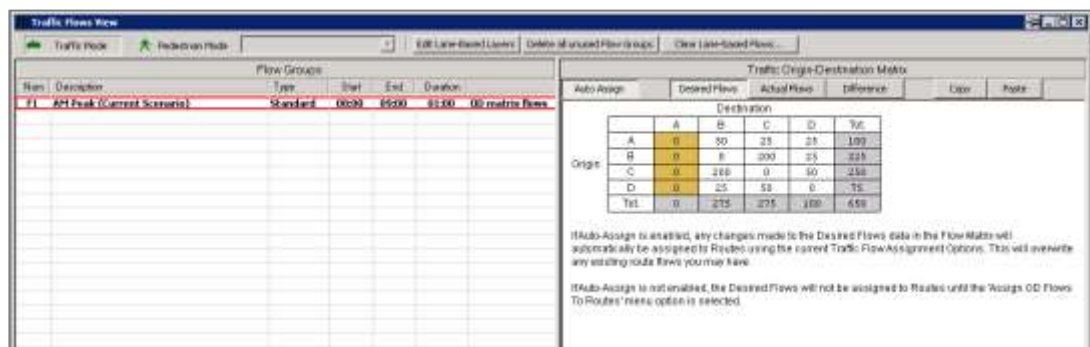

Figure 69: Traffic Flow OD Matrix shown in the Traffic Flows View

For a network of junctions an OD survey should ideally be used to populate the matrix. However, where this is not possible, separate junction turning count surveys can be used and converted into a combined OD format, using manual flow smoothing, or an estimated assignment model with a verified prior matrix.

When flows have been entered into an OD matrix, they can be applied to all possible zone-to-zone Routes manually or by automatically assigning flows to Routes based on calculated delay or the balancing of flow on entry Arms. When using automatic assignment in LinSig, it is recommended that Delay-Based assignment is used, except in special situations such as

the modelling of a signalised roundabouts, where the assignment choice should be documented.

Where multiple Route choices are available within the network, checks should be carried out to ensure that traffic flows have been assigned correctly. If necessary, flows may need to be manually 'locked' on specific Routes based on site observations. This can be achieved using the 'Route List View' (Figure 70) to get correct Lane usage, before allowing LinSig to allocate flows to other permitted Routes.

Route	Org Zone	Dest Zone	Org Lane	Dest Lane	Route Flow	Flow Locked?	Bus Route?	Journey (PCU/h)	Delay (PCU/s)	Total Delays (pcu/h)	Total Journeys (pcu/h)
1	A	B	J2:1/1	J2:4/1	50			64.75	34.36	0.75	0.90
3	A	C	J2:1/2	J1:6/1	25			86.63	58.43	0.39	0.60
2	A	C	J2:1/2	J1:6/2	0			-	-	0.00	0.00
8	A	D	J2:1/2	J1:4/1	25	<input checked="" type="checkbox"/>		81.91	56.91	0.40	0.57
5	B	C	J2:2/1	J1:6/1	120	<input checked="" type="checkbox"/>		40.22	33.27	0.26	1.38
4	B	C	J2:2/2	J1:6/2	80			40.22	33.28	0.23	0.89
9	B	D	J2:2/2	J1:4/1	25			38.05	11.05	0.08	0.25
7	C	B	J1:3/1	J2:4/1	72			39.96	9.96	0.20	0.80
6	C	B	J1:3/2	J2:4/2	128			40.00	10.00	0.36	1.40
10	C	D	J1:3/1	J1:4/1	50			17.44	7.44	0.10	0.24
11	D	B	J1:1/1	J2:4/1	25			43.68	33.68	0.23	0.44
12	D	C	J1:1/1	J1:6/2	50			46.71	30.71	0.43	0.57

Figure 70: Route List View

If circular routes or U-turns are possible within a model, typically at roundabouts but also with closely associated junctions, these Routes must be manually checked in the 'Route View'. If unrealistic Routes are generated, such as those that are not observed on street, these should be removed using the 'Edit Permitted Routes' feature (Figure 71).

Route	Permitted	Org Zone	Dest Zone	Org Lane	Dest Lane	Flow	Lock Route Flow	Bus Route
1	<input checked="" type="checkbox"/> Use Policy (Allow)	A	B	J2:1/1	J2:4/1	50	<input type="checkbox"/> Unlocked	
3	<input checked="" type="checkbox"/> Use Policy (Allow)	A	C	J2:1/2	J1:6/1	25	<input type="checkbox"/> Unlocked	
2	<input checked="" type="checkbox"/> Use Policy (Allow)	A	C	J2:1/2	J1:6/2	0	<input type="checkbox"/> Unlocked	
8	<input checked="" type="checkbox"/> Use Policy (Allow)	A	D	J2:1/2	J1:4/1	25	<input type="checkbox"/> Unlocked	
5	<input checked="" type="checkbox"/> Use Policy (Allow)	B	C	J2:2/1	J1:6/1	120	<input checked="" type="checkbox"/> Locked	
4	<input checked="" type="checkbox"/> Use Policy (Allow)	B	C	J2:2/2	J1:6/2	80	<input type="checkbox"/> Unlocked	
9	<input checked="" type="checkbox"/> Use Policy (Allow)	B	D	J2:2/2	J1:4/1	25	<input type="checkbox"/> Unlocked	
7	<input checked="" type="checkbox"/> Use Policy (Allow)	C	B	J1:3/1	J2:4/1	72	<input type="checkbox"/> Unlocked	
6	<input checked="" type="checkbox"/> Use Policy (Allow)	C	B	J1:3/2	J2:4/2	128	<input type="checkbox"/> Unlocked	
10	<input checked="" type="checkbox"/> Use Policy (Allow)	C	D	J1:3/1	J1:4/1	50	<input type="checkbox"/> Unlocked	
11	<input checked="" type="checkbox"/> Use Policy (Allow)	D	B	J1:1/1	J2:4/1	25	<input type="checkbox"/> Unlocked	
12	<input checked="" type="checkbox"/> Use Policy (Allow)	D	C	J1:1/1	J1:6/2	50	<input type="checkbox"/> Unlocked	

Figure 71: Edit Permitted Routes View

For each scenario being modelled, it is important to verify that the total flow applied to all routes between an OD pair matches the Desired Flow Matrix that has been manually populated from the survey data. The Difference tab on the Traffic OD Matrix highlights any differences between desired and actual flow values (**Figure 72**).

Traffic Origin-Destination Matrix						
Auto Assign	Desired Flows	Actual Flows	Difference	Copy	Paste	
		Destination				
	A	B	C	D	Tot.	
Origin	A	0	0	0	-25	-25
	B	0	0	0	0	0
	C	0	-50	0	0	-50
	D	0	0	0	0	0
	Tot.	0	-50	0	-25	-75

If Auto-Assign is enabled, any changes made to the Desired Flows data in the Flow Matrix will automatically be assigned to Routes using the current Traffic Flow Assignment Options. This will overwrite any existing route flows you may have.

If Auto-Assign is not enabled, the Desired Flows will not be assigned to Routes until the 'Assign OD Flows To Routes' menu option is selected.

Figure 72: Traffic OD Matrix Difference view, indicating where desired and actual flows are not matching in grey

The allocation of flows using a matrix is acceptable for fixed Routes (such as buses) or in smaller models where minimal Lane and Route choice exists or where the OD matrix is known (for example signalised roundabouts). For detailed reporting on journey times the use of a microsimulation model is recommended, however indicative journey times can be extracted from LinSig files which use Matrix-Based layers, as described in **B4.7.3**.

4.4.6.3 Matrix Estimation

JCT suggest that OD matrices for individual junctions and simple networks can often be derived directly from turning count data, however they do not consider this feasible for larger networks of four or more junctions⁷³. Matrix Estimation is a method by which OD matrices for a larger modelled network can be derived from individual junction turning counts. In networks where signals are closely spaced, the importance of having accurate OD information is vital to obtain workable offsets.

LinSig uses the long-established Maximum Entropy method for Matrix Estimation, which is widely used in strategic modelling software. It essentially tries to improve the fit between modelled and observed flows by selectively factoring individual cells of the input trip matrix.

While Matrix Estimation may appear to offer an attractive option for generating an OD matrix, it is important to be aware of the limitations and potential pitfalls of the process. The first run of Matrix Estimation shouldn't be accepted and used, the matrix needs careful assessment and further refinements to the traffic counts or network may be necessary to produce an acceptable matrix. It is the modeller's responsibility to ensure that matrices are checked sufficiently before being used in a scheme assessment.

It is not generally recommended that Matrix Estimation is used within LinSig. It is preferred that OD surveys are collected or a tactical assignment model is used. Any use of Matrix Estimation in LinSig should therefore be agreed in advance.

Before undertaking Matrix Estimation within LinSig, it is imperative that the turning count data is checked for consistency as any errors in the data will lead to poor Matrix Estimation. The main checks to be undertaken are:

- There is a good coverage of turning count data;
- The turning count data is sufficiently recent;
- There are no significant inconsistencies between adjacent counts; and
- Any major sinks and sources of flow are accounted for.

Within LinSig, the following information will need to be updated for each Flow Group before commencing Matrix Estimation:

- Turning count data, in PCUs;
- Zone OD totals;
- Traffic signal data, including signal timings running at the time of the traffic counts, stage sequences and network control plans; and
- Network structure, including connector structure, saturation flows and cruise times.

For Highway Traffic Assignment models, it is strongly recommended that an old or prior matrix is updated using observed counts, by undertaking Matrix Estimation. The prior matrix will typically be derived from a demand model (using socio-economic and/or other traffic data) or an older version of the model. If no prior matrix is available the model assumes that all trips are equally likely. This can lead to a poor trip length distribution with, for example, too many short or long trips, and unrealistic OD trips. A prior matrix is advisable if an OD matrix is being derived from junction turning flow data in LinSig, as Matrix Estimation won't necessarily assign trips to the correct path even in smaller networks. Therefore, it is recommended that a fully validated tactical model is used for the Matrix Estimation process, using dedicated assignment software and a verified prior matrix.

Another technique to obtain OD matrices for use in LinSig is through Automatic Number Plate Recognition (ANPR) or video data. With this more recent technique, cameras are typically positioned to form a 'cordon' to capture all vehicles entering and exiting the cordon. This technique is the most accurate but also the most expensive. The benefit of a prior matrix is greatly reduced with this technique as OD paths will be captured from video or ANPR data. However, where route choice exists, there may be a requirement to supplement the ANPR data with turning count or screenline data to validate the route choices.

Any matrices that are produced as a result of Matrix Estimation should be carefully checked to ensure that they are of an acceptable standard to be used in further modelling. A process of refining the matrix should be anticipated prior to achieving the final matrix.

4.4.7 Public Transport

Bus flows can be added to a LinSig model using the following options to enable buses to be differentiated from general traffic:

- **Lane-Based Flow Layers** – One or more Lane-Based Flow Layers can be added on each Lane according to their routes. Each additional Lane-Based Flow Layer should be specified as representing buses; or

- **Matrix-Based Routes** – Zone-Based routing can be used to represent bus flow through the network. The permitted routing for bus flow should be edited or fixed to ensure correct Lane usage. Relevant Zones should be specified as Bus Zones.

Where bus stops exist on a Lane, the upstream Connector should be edited to set the average bus dwell time at that stop. If there is more than one stop on that Lane, the Mean Bus Stopped time should reflect the sum of all bus stop dwell times, together with an additional delay to represent the acceleration and deceleration at any additional stops. Bus stop dwell times can be as surveyed on street or appropriate estimated values can be used if necessary. It is possible to customise the Mean Bus Stopped times for an individual Lane-Based Flow Layer or Zone-Based Route, should this level of detail be required for the scheme being assessed.

Where public transport influences general traffic, such as at bus lane setbacks and funnelling at bus lane entries, these conditions should be observed on street and replicated in the modelled network.

If bus lanes do not extend all the way to the stopline, a bus setback is created which allows general traffic to use the short lane in front of the bus lane (for example for left-turning vehicles). This should be modelled as a Short Lane in LinSig, with the bus lane having a negative bonus green applied to represent the time taken for buses to travel from the end of the 'effective' bus lane to the signal stopline. The bus lane setback negative bonus green should be measured for each modelled period as it may vary according to time of day. See section [B4.5.1](#) for further guidance on the application of bonus greens in LinSig.

The default Bus Delay Weighting currently used in the LinSig optimisation process prioritises bus delay over general traffic delay by a factor of ten. If required this can be adjusted in the Optimiser Settings view, as described in section [B4.6.4.1.3](#).

Dynamic control strategies, such as SVD bus priority, cannot be explicitly modelled in LinSig as a typical cycle is modelled. These strategies can be represented by adjusting the signal timings in the network to represent those running on street.

4.4.8 Pedestrians

The pedestrian network in LinSig consists of Pedestrian Links, Pedestrian Link Connectors and Pedestrian Zones, as shown in **Figure 73**.

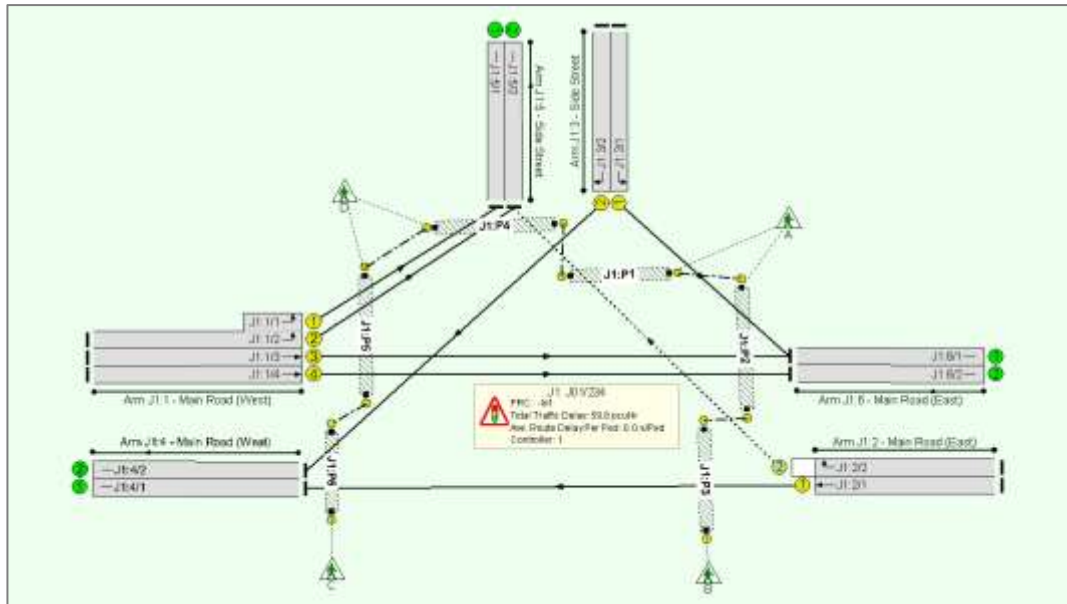

Figure 73: Example junction showing a pedestrian network in LinSig

Pedestrian Links can be added to the modelled network to represent where pedestrian crossings are provided on site. Pedestrian Links at individual junctions can be joined by Pedestrian Link Connectors to form a pedestrian network. Pedestrian Links require the following data to be added:

- Associated junction;
- Controlling Phase, if the crossing is signalised; and
- Crossing Time (sec), generally derived from observed data or by dividing the link length by an average pedestrian walking speed of 1.2m/s.

A mean walking time between crossings (sec) is required on Pedestrian Link Connectors. In the absence of observed data, the walking time can be derived based on a walking speed of 1.2m/s. Due to the complexity of pedestrian behaviour it is not advised to connect Pedestrian Links between junctions.

Pedestrian flows can be added at a junction via Pedestrian Zones and Routings. Either observed data or a nominal value of 1 can be entered into the Pedestrian OD Matrix for all pedestrian movements. It should be noted that LinSig reports pedestrian outputs in terms of PCUs, however the values are referring to pedestrian numbers.

LinSig uses the pedestrian network to determine pedestrian journey and delay times for each Pedestrian Route through the junction. These can be viewed in the Pedestrian Route List. If this involves several crossings LinSig takes account of pedestrian coordination together with the time taken to walk between crossings when modelling delays. Where nominal pedestrian flows have been used, only the journey and delay statistics per pedestrian should be used for comparison. Pedestrian journey time and delay calculations should only be compared for signalised pedestrian crossings as unsignalised crossings are not modelled accurately and are included for delay purposes only.

Where detailed pedestrian analysis is required, consideration should be given to using dedicated pedestrian modelling software to assess any pedestrian impacts of a scheme. For pedestrian modelling information, refer to Chapter **C3** on **Pedestrian Modelling**.

4.4.9 Cyclists

For advice on the modelling of cyclists in deterministic modelling packages such as LinSig, refer to Chapter **C2** on **Cyclist Modelling**.

Within LinSig, cyclist flows can be entered as their PCU contribution in Lane-Based Flow Layers or an OD Matrix. It is possible to override the Connector cruise times by Flow Layer to reflect differences by mode if this level of detail is required. If using Matrix-Based Flows, separate Zones for cyclists are required to override the Connector cruise times. In mixed traffic conditions, modelling outputs in the Travel Time / Delay Matrices will not show how cyclist queuing behaviour is different to other vehicle types on the Lane.

4.5 Base Model Validation

Base models must demonstrate that they replicate observed conditions to a sufficiently high level of accuracy, as described in [B2.4.1](#) and [B2.4.2](#). This section describes the validation requirements with respect to LinSig and additional adjustments to ensure on-street conditions are accurately reflected in the model.

4.5.1 Demand Dependency

The frequency of demand-dependent stage appearance should be measured directly from the UTC system for UTC-controlled junctions, or through on-street observation for non-UTC sites where stage appearance data is not readily available, as described in [B2.3.8.5](#).

Demand dependency cannot be explicitly modelled in LinSig, as only a typical cycle is simulated. The appearance of demand-dependent stages is therefore achieved by manipulation of the signal timings.

Bonus greens can be applied to the green period for each Lane to reflect the non-appearance of demand-dependent stages. This is applied in the Lane Timings View and can be seen in [Figure 74](#). Bonus greens can be positive or negative, depending on whether a phase gains or loses green time due to demand dependency.

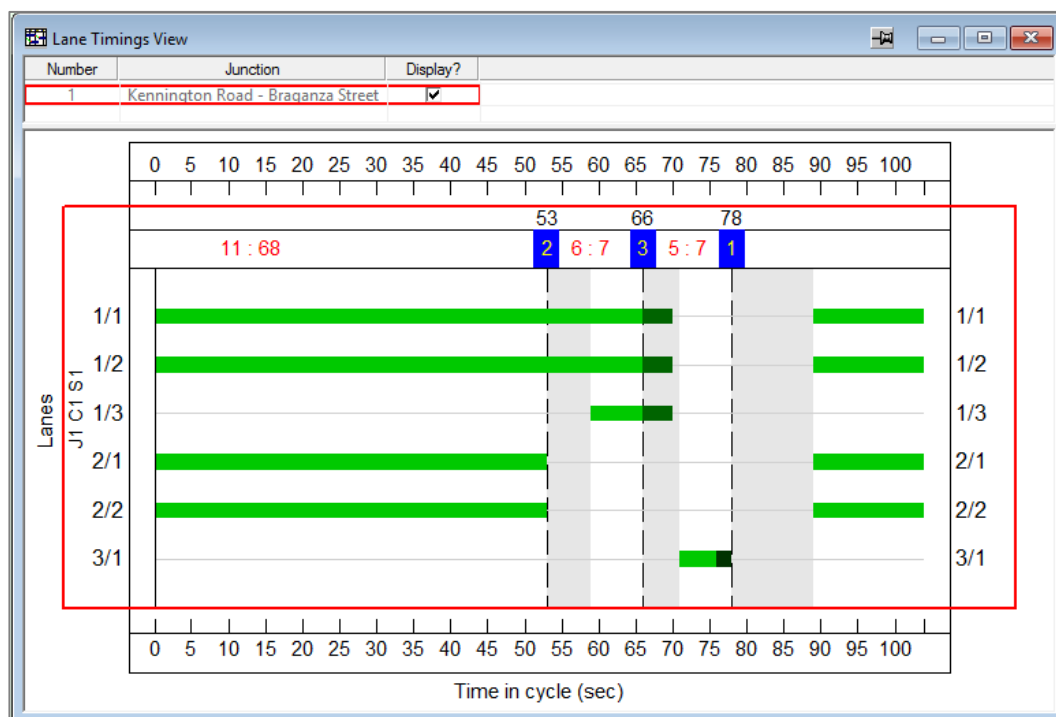

Figure 74: Lane Timings View, showing positive bonus green applied to Lanes 1/1, 1/2 and 1/3, and a negative bonus green applied to Lane 3/1

4.5.2 Exit-blocking / Underutilised Green Time

Wasted green due to exit-blocking can be quantified through on-site measurement of Underutilised Green Time (UGT). UGT accounts for both wasted green due to exit-blocking, during which traffic is stationary, and sub-saturated flow, during which traffic is slow moving due to downstream queuing and congestion.

Exit-blocking can be accounted for in a LinSig Base model through the use of negative bonus greens, which are applied in the Lane Timings View as shown in **Figure 74**. The application of this technique needs to be supported by site observation and empirical data, such as UGT measurements during a DoS survey (discussed further in **B2.3.10**).

Care should be taken when applying bonus greens for Underutilised Green Times in LinSig. A positive average UGT value should be entered as a negative bonus green value in LinSig, resulting in a reduction of Lane green time.

It is important to note that the cause of exit-blocking cannot be modelled in LinSig. Where extensive exit-blocking exists within a network, consideration should be given to use of microsimulation modelling in order to represent both the cause and effect of exit-blocking.

4.5.3 Sliver Queues

Due to the simplified mathematical nature of a deterministic software model, behaviour can sometimes occur in a model that is not reflected by driver behaviour in the real world. An example of this within LinSig is the formation of 'sliver queues'.

A sliver queue occurs when vehicles approach the back of a discharging queue of traffic. In practice, drivers will typically regulate their speed if they see a queued vehicle in front of them is about to accelerate, whereas in LinSig they are assumed to progress at free-flow speed until they join the back of the stationary queue. This can lead to successive vehicles joining the back of a modelled queue that leads to excessive and unrepresentative queuing behaviour. A modeller can set a 'De-sliver threshold' (in PCUs) in order to prevent the formation of sliver queues. This value is the minimum queue that will actually form on street, meaning LinSig regards any queue length less than this value as a sliver queue.

A modeller can recognise the formation of a sliver queue by examining the LinSig queue data or a uniform queue graph. As **Figure 75** illustrates, the

data will highlight a small amount of traffic in the queue relative to the total queue length. The right-hand image shows the same link with an appropriate de-sliver threshold applied.

Where a sliver queue has been identified it is acceptable to enter a de-sliver threshold value of no more than one PCU. It is recommended that the smallest possible value is used to achieve the desired effect of removing the unrealistic queue. Where this function has been used it should be clearly stated within the accompanying model report.

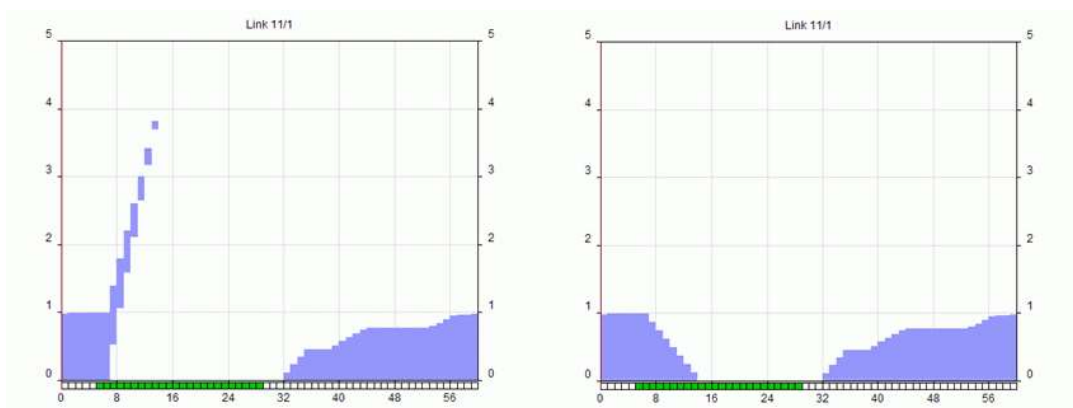

Figure 75: Formation of a sliver queue in a LinSig uniform queue graph (left) and removal using appropriate de-sliver threshold (right)

4.5.4 Random Delay

Random delay relates to how random or ordered traffic arrives at a stopline and is a component in the calculation of total delay in LinSig. The LinSig model assumes a level of random delay that sits between very random and very ordered arrival patterns. In some circumstances this assumption may be unrealistic, such as for highly coordinated signals at a signalised roundabout where the majority of traffic will arrive without being stopped at a red signal. In these instances, the Ignore Random Delay function should be ticked to avoid an overestimation of random delay and an improvement in the calculation of queuing.

The Ignore Random Delay feature is applied on a Lane by Lane basis, but should only be ticked when the arrival pattern at the stopline has definite non-random characteristics.

4.5.5 Validated Model Requirements

Model outputs for individual Lanes should be compared with corresponding survey data in order to validate that the model has been calibrated to an acceptable degree of accuracy, as described in **B2.4.2**.

The validated Base LinSig model will be based on the calibrated model approved at LMAP Stage 2, but will also include traffic flows and account for any measured demand dependency or exit-blocking. It is essential that a Base scenario LinSig model is validated against existing network conditions using current signal timings.

Validation criteria for LinSig Base models submitted to TfL are defined in LMAP Stage 3, as discussed in **B2.1.5**. At the time of publishing, these are⁷⁴:

- DoS within 5% of observed values;
- DoS for Lanes upstream of pedestrian crossings within 10% of observed values; and
- Observed Cyclic Flow Profiles (CFP) for critical Links showing similar peaks, dispersion and spacing.

If modelled flows are based on surveyed stopline turning counts then Degrees of Saturation (DoS) at those stoplines should not exceed 100%. If any Lane has a DoS above 100% it should be investigated before proceeding, as it is usually a sign that the model is seriously in error.

If instead the modelled flows represent true traffic demand, as determined from an assignment model or survey well upstream of any queue, then the DoS may exceed 100%. If this is the case, validation should focus on comparing the capacity of the Lane in the model against site-measured spot counts.

Possible causes of invalid DoS values in a model include:

- The measured flow data for a particular Lane is inaccurate, or has been entered into the model incorrectly;
- The saturation flow is too low / high;
- Signal timings or UGT have been entered incorrectly; or
- One or more demand-dependent stages have not been modelled correctly.

If a scheme requires reporting on bus journey times, it is recommended that bus journey times are validated using a microsimulation model before reporting scheme impacts on public transport. Any bus results extracted from a LinSig model should be for indicative purposes only.

74 Latest MAP requirements are available at <https://www.tfl.gov.uk/trafficmodelling>

4.6 Proposed Model Development

This section details the considerations to be made when creating a Proposed LinSig model. Proposed models should be implemented using the validated Base model as a starting point, or the Future Base model if following the Three Stage Modelling Process covered in **B2.1.4**. The models should be modified to fully detail the proposed design changes, as described in **B2.5**.

4.6.1 Future Base

As described in **B2.5.1**, the Future Base model includes all likely network changes that will occur between the Base year and the year being examined in the proposal, excluding the scheme under consideration. It is built from the validated Base model by modifying it as little as possible, to include any new schemes falling within the LinSig model boundary. The guidance in the following sections within **B4.6** applies equally to creating the Future Base model as well as to the Proposed scenarios.

4.6.2 Proposed Layout

Modifications should only be made from the validated Base model or Future Base model that reflect changes required as part of the scheme designs. Further amendments to the model to make a model operate within capacity are not acceptable. If a Proposed model will not operate without additional changes it is likely an indication that the design may not be viable.

Where flare lengths have been defined by length, any changes to Proposed flows will automatically be used in flare usage calculations. Where custom occupancies or Multi-Lane flares have been used, consideration will need to be given as to how the proposals and changes in flow will impact the expected flare usage.

When modelling new proposals, the treatment of 'funnelling' and 'fanning' traffic can become a possible source of error. 'Funnelling' occurs when a greater number of Lanes at one signal-controlled stopline exit into a fewer number of Lanes downstream, while 'fanning' represents the opposite scenario, where fewer Lanes upstream flow into more Lanes downstream. This behaviour should be reflected in the modelled layout where funnelling forces Lanes of continuous length to behave like flares or with modified capacity where fanning results in underutilisation of downstream stoplines.

4.6.3 Proposed Flows

Proposed traffic flows can be applied to a LinSig model in a number of different ways, as detailed in the subsequent sections. The methodology to be used for Proposed flows should be discussed at the Base scoping meeting during MAP Stage 1 and agreed at the Proposal Scoping Meeting during MAP Stage 4, as described in **B2.1.5.1**. This ensures that the most appropriate methodology is used.

Future year flows of cyclists and pedestrians are typically agreed on a project-specific basis. Refer to Chapter **C2** on **Cyclist Modelling** and Chapter **C3** on **Pedestrian Modelling** for further details.

4.6.3.1 Manual Editing

Traffic flows can be adjusted by manually editing the Lane-Based or Matrix-Based flows in the validated Base or Future Base model. Manual adjustments to traffic flows may be complicated where movements are introduced or banned as part of the proposals. Where this is the case, a decision must be agreed as to how traffic should be rerouted. If the rerouting is likely to be widespread then tactical modelling may be necessary.

Additional Flow Layers or Flow Groups can be created to represent additional development flows within a model when using respective Lane-Based or Matrix-Based flow allocation methods. This allows for development flows to be differentiated from Base flows. Formula Flow Groups can be used to combine multiple Flow Groups together for use in a single model Scenario, or for applying a growth factor to an existing Flow Group.

4.6.3.2 Tactical Modelling

As explained in **B2.5.2.2**, the Three Stage Modelling Process will often lead to traffic flows for Proposed LinSig models being transferred from tactical modelling. The tactical flows and routing can be transferred directly into the LinSig model or they can be used to inform factored values from the Base model flows. If relevant to the proposals, any assumptions made whilst inputting the Base model flows should be maintained in the Proposed models.

Any changes made to traffic flows or routings in the Base model for validation purposes should be carried across appropriately to the Proposed models.

4.6.3.3 Public Transport

Any changes to bus routes as part of the proposals should be included within the Proposed LinSig model. This will require manual adjustments to the flow layer representing buses or to the bus flow matrix.

Any changes to bus stop locations or dwell times should be reflected on the appropriate Connectors.

4.6.4 Proposed Signal Timings

It is important to ensure that Proposed signal designs are audited by a TfL Signals Engineer to ensure that they meet current TfL standards. Once approved, signal timings in the Proposals should be developed and optimised following the methodology and guidance described in **B2.5.3**.

Existing Junction or Controller Stream numbering within a validated Base model should not be changed within a Proposed model unless necessary. New items should be added using an appropriate numbering / naming convention and highlighted within the proposal report.

Where a new junction is to be added to the Proposed model and the controller manufacturer is known, the controller type should be correctly assigned. This is to ensure any gaining phase delays are correctly modelled, as mentioned in **B4.4.4.2**. For a proposed junction that does not currently exist and for which the hardware to be used is not known, the controller type should be set to 'generic'.

4.6.4.1 Optimisation

LinSig can optimise signal timings using two different objectives, by maximising Practical Reserve Capacity (PRC) or minimising total network delay. These can be applied to the network as a whole or to individual junctions and stage streams. These criteria may lead to similar results but the choice of method should be determined based on the design objectives agreed during MAP Stage I.

LinSig selects initial signal timings using a simple analytical junction model to calculate optimal green splits. A hybrid strategy based on a combination of traditional optimisation methods is then used to determine where changes to initial green splits and offsets could potentially improve network performance. The traffic model then reruns using the potentially improved signal timings. If it is shown that these timings were better than previous results LinSig uses these timings to try and predict further improvements. LinSig monitors progress to target optimisation effort at the areas where most improvements are likely to be realised.

LinSig does not run the optimisation process for a fixed number of iterations. JCT feel a fixed approach can risk the optimiser terminating early with complex networks, leading to signal timings that do not represent optimal network performance. LinSig instead varies the number of iterations according to the complexity of the network and other issues such as the level of traffic in the network. LinSig will let the optimiser continue where significant improvements are gained with a relatively minor extension of the run time. When the optimiser fails to achieve improvements within an acceptable time the optimisation process will terminate.

In addition to the optimisation process, signal timings within LinSig are able to be manually adjusted in order to meet site-specific requirements or during further refinement of optimised timings.

4.6.4.1.1 Cycle Time Optimisation

The Cycle Time Optimisation View can be used to assess the optimum cycle time for a LinSig model. This feature plots PRC and delay results for a model against cycle time, for a specified range of cycle times and cycle time increments.

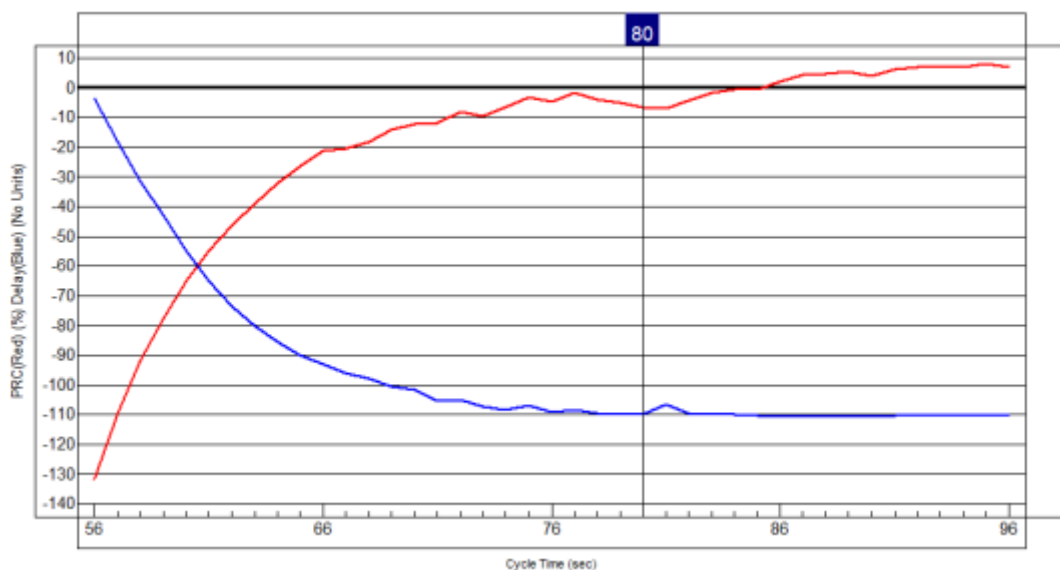

Figure 76: Cycle Time Optimisation View in LinSig, showing PRC (in red) and delay (in blue) for different cycle times

The most appropriate cycle time must be chosen and manually applied in the LinSig model. Section **B2.5.6.1.3** provides guidance on available cycle times, as well as important considerations which may influence the choice of cycle time.

4.6.4.1.2 Signal Timing Optimisation

Stage lengths and/or stage offsets can be optimised either for minimum delay or maximum PRC, depending on which is considered the most appropriate methodology during the initial determination of model scope. A network can either be optimised at a controller level, via the Signal Timings Window or for the entire network via toolbar buttons or the Modelling menu.

The generic procedure for optimising a traffic model is discussed in [B2.5.3](#). During the initial optimisation phase, signal timings in LinSig can be influenced through Queue Constraints and Weightings for each Lane. Queue Constraints can be used to prevent queues extending back to upstream junctions, and use the following parameters:

- **Excess Queue Limit (PCU)** – this is used to specify the acceptable limit for a queue on a particular Lane, accounting for limited storage space on the Lane that may lead to blocking back to upstream Lanes. If the queue extends beyond this limit LinSig will attempt to adjust timings to reduce the queue. A suitable excess queue limit needs to consider that the Mean Max Queue (MMQ) reported in LinSig will statistically be exceeded 50% of the time. JCT therefore recommend that a queue limit of three quarters of Lane storage capacity is used. This is to ensure that any queue fluctuations above the MMQ stay within the Lane length;
- **Degree of Saturation Weighting (%)** – this value is only used when optimising for PRC, and determines the aggressiveness LinSig will use in reducing the average excess queue where an excess queue limit has been applied; and
- **Delay Weighting (PCU Hr)** – this serves the same purpose as the Degree of Saturation Weighting, but is used when optimising timings for delay rather than PRC.

Optimiser weightings can be used to prioritise the importance of a Lane when determining signal timings. There are three parameters controlling the optimiser weightings:

- **Optimiser Stops Weighting (%)** – this is used to factor up or down the penalty of any Stops calculated on a Lane. Values less than 100 will reduce the importance of stops on the Lane whereas values greater than 100 will increase the importance;
- **Optimiser Delay / Degree of Saturation Weighting (%)** – Similar to the stop weighting, this weighting factors up or down the importance

of delay or DoS on this Lane, dependent on the optimisation method used; and

- **Degree of Saturation Limit (%)** – This parameter prevents the optimiser choosing signal timings that generate a DoS on a specified Lane exceeding this value.

When using Queue Constraints and Weightings high values may prevent the optimiser producing optimal signal timings. The use of optimiser weightings should be detailed in accompanying model reports.

It is important to note that optimiser Weightings should be used with care. They do not replace engineering judgement and the manual adjustment of signal timings relating to safety constraints or on-site conditions. Any use of optimiser Weightings should be clearly detailed within the technical note, along with a justification for their use.

4.6.4.1.3 Optimisation Settings

The optimisation process within a LinSig model can be controlled within the Optimiser Settings. The parameters included in the settings include:

- **Optimising pedestrian and non-traffic stages lengths to minimums;**
- **Stops Valuation for Delay** – the default value is 6.59 sec per stop/PCU. This considers vehicle stops in the optimisation process, where small increases in traffic delay are preferred over larger decreases in the number of PCUs stopping at traffic signals; and
- **Bus Delay Weighting** – the default value is 1000%. This default assumes that avoiding bus delay within the modelled network is 10 times more important during optimisation than avoiding general traffic delay, which has a default value of 100%. Decreasing the default value will lower the importance of bus delay and conversely increasing the default value will increase the importance.

Any amendments to the default values should be justified in the supporting documentation.

Within the optimiser settings it is possible to group together controllers or stage streams to fix stage offsets. This process fixes the offsets between the first stage in the stage sequence for each controller or stream that has been included in an offset optimiser group.

The optimisation process can be further influenced within the signal timings view, as follows:

- **Allow Edit Timings** – If this is unticked for a controller or stage stream the timings will be omitted from the optimisation process;
- **Lock Length of Stage when Optimising** – This setting will fix the stage length for the selected stage within the optimisation process; and
- **Lock Offset of First Stage in Sequence** – This setting fixes the pulse point of the first stage in the stage sequence, overriding the optimiser settings or offset groupings.

Any influence on the optimisation process should be carefully considered prior to use and detailed in accompanying documentation.

4.6.4.2 Demand Dependency

When calibrating demand dependency levels in a Proposed model it should be carefully considered whether there is reason to believe they will change from the Base or Future Base model. Where considered necessary, a suitable methodology should be determined to ensure that any estimated demand levels are appropriate. Assuming full demand as a 'worst case' could in fact mask a capacity issue downstream so a judgement on the expected demand should be agreed and documented. For further information refer to [B2.5.2.3](#).

4.6.4.3 Underutilised Green Time

Where adjustments have been made in the validated Base model to reflect Underutilised Green Time (UGT), consideration should be given to the cause of the UGT before determining whether any modifications are appropriate or necessary in the Proposed models. If unsure whether to amend Base UGT values, it is recommended that the MAE is contacted to determine the best approach. For further information refer to [B2.5.6.1.1](#).

4.6.4.4 Saturation Flows

Saturation flows should only be changed from the Base model if there is clear evidence that they would be different in the Proposed scenario.

Reasons for this include:

- A new junction or major layout change;
- Change in lane width; or
- Change in flow volumes for particular turning movements.

If any of these apply then RR67 should be used with an appropriate local factor as discussed in **B2.3.9.1** to implement new saturation flows using the methods described in section **B4.4.3.7**. The reasoning behind any changes must be documented in the accompanying modelling report.

4.7 LinSig Output

LinSig offers a variety of output features that can aid in the analysis and reporting of model performance, which are detailed in this section.

4.7.1 Network Results

The Network Results View allows data and performance statistics to be displayed for every Lane and Pedestrian Link in the model, as shown in [Figure 77](#). The exact data that is displayed is user-customisable and can contain a mixture of input data (including flows, saturation flows, phase letters and Lane green times) and output data (including DoS, delay and queue information).

Lane	Lane Type	Sat Flow	Cap	Flow	Delay	DoS	Queue													
Network		69.4%		0	72	2	3.8													
122+1/1	Main Road (West) Left	U	N/A	B	1	14	13	27	66	1808	1808	500	11.8%	68	68				8.3	
1/3	Main Road (West) Ahead	U	N/A	N/A	B	1	14	13	27	308	3080	1808	480	22.2%	308	308				8.3
1/4	Main Road (West) Ahead	U	N/A	N/A	B	1	14	13	27	308	3080	1808	480	22.2%	308	308				8.3
2/5	Main Road (East) Ahead	U	N/A	N/A	A	1	11	54	5	258	3080	1808	340	28.8%	258	258				1.5
2/2	Main Road (East) Right	U	N/A	N/A	A	1	11	84	5	75	3080	1808	340	28.8%	75	75	0	72	2	8.4
3/1	Side Street Left	U	N/A	N/A	C	1	11	35	46	75	3080	1808	340	28.8%	75	75				8.4
3/2	Side Street Right	U	N/A	N/A	C	1	11	35	46	75	3080	1808	340	28.8%	75	75				8.3

PRC for Signalled Lanes (%) 29.8 Total Delay for Signalled Lanes (sec/h) 8.78 90
 PRC Over All Lanes (%) 29.8 Total Delay Over All Lanes (sec/h) 8.78 Cycle Time (s)

Figure 77: Network Results View

As well as identifying performance parameters for individual Lanes, the Network Results View also displays PRC and delay information for individual junctions or the entire network. Results for individual Lanes can also be further broken down into specific Routes through individual Lanes.

It is possible to filter the data included in the Network Results View, so that results can be shown on the following conditions:

- All Lanes;
- All Routes passing over a selected Lane;
- All Lanes controlled by a selected stage stream;
- All Lanes along a selected Route; and
- Including or excluding Exit Lanes.

4.7.2 Cyclic Flow Profile, Uniform Queue and Storage Graphs

Cyclic Flow Profile (CFP) graphs show traffic flow arrival and discharge patterns for a particular stopline during a typical cycle. These can be plotted for individual Lanes, grouped Lanes, right turn storage areas or for whole routes. Where CFPs are plotted for an individual Lane they can be set up to show arrival and/or discharge flows, and can be further broken down into flows associated with individual Routes. Where a whole Route is plotted, a CFP graph is provided for each stopline along the Route, allowing analysis or platoon progression along the Route selected. An example of a CFP graph is shown in **Figure 78**, where the X axis represents the time in the cycle and the Y axis represents the rate of traffic arrivals / departures in PCU/hr.

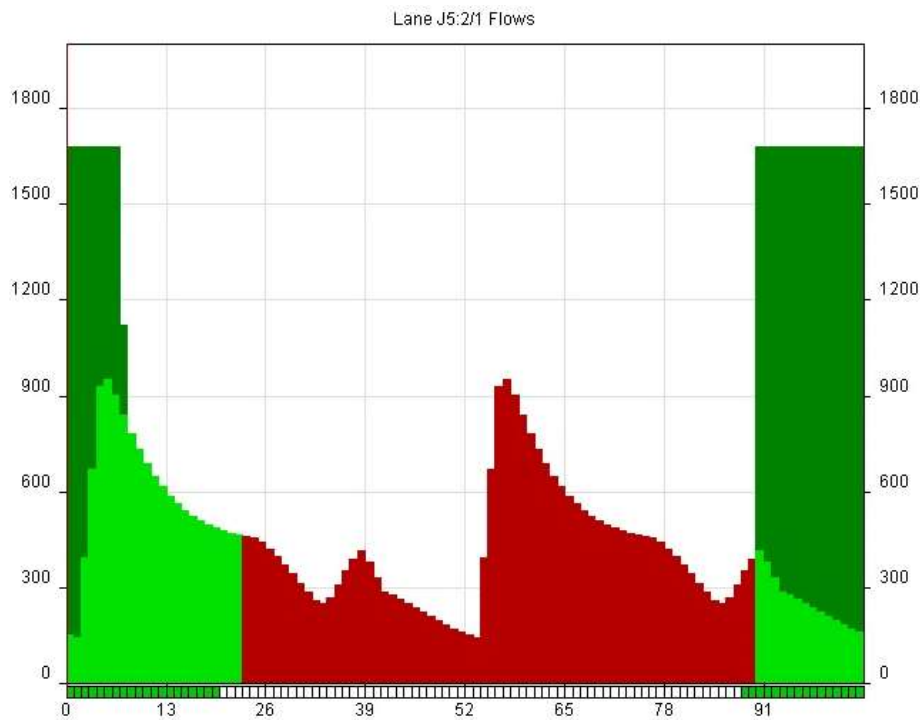

Figure 78: Cyclic Flow Profile graph, showing previously delayed vehicles (dark green), vehicles arriving on green (light green) and vehicles arriving on a red (red)

Uniform queue graphs can also be plotted for individual Lanes or grouped Lanes. These show the uniform component of a queue, not including random and oversaturated queue components. An example of a uniform queue graph is shown in **Figure 79**.

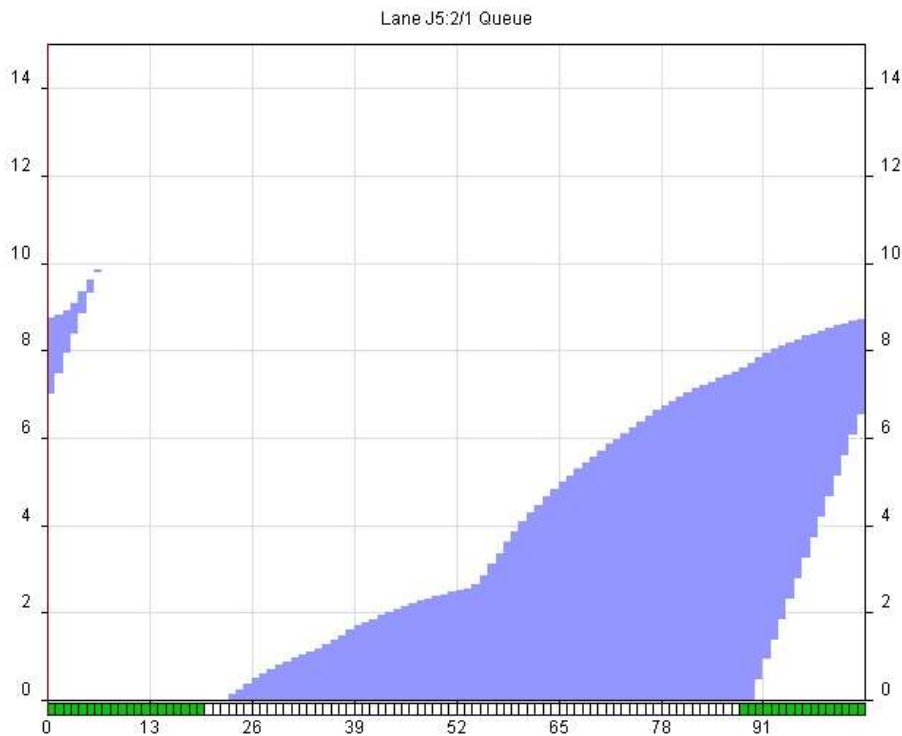

Figure 79: Uniform Queue graph in LinSig

When a Lane has a DoS less than 80% the uniform queue is an accurate representation of the average queue on a Lane, however when operating above 90% the random and oversaturated queue components become more critical and the uniform queue graph should not be relied on to predict queue storage issues.

Optionally the random and oversaturated queue component can be shown on the queue graphs as a flat profile throughout the cycle time.

Storage graphs can be plotted for Short Lanes or right turn storage areas to assess when traffic using these Lanes is likely to start blocking or influencing adjacent Lanes. Storage graphs can also be produced on Long Lanes in a Lane Group to determine when the traffic on a Long Lane will prevent entry to its adjacent Short Lane. Storage graphs can be helpful to check that flare utilisation is as observed on-street and can determine whether a Short Lane custom occupancy is required, as discussed in **B4.4.3.5**. Example storage graphs are shown in **Figure 80**.

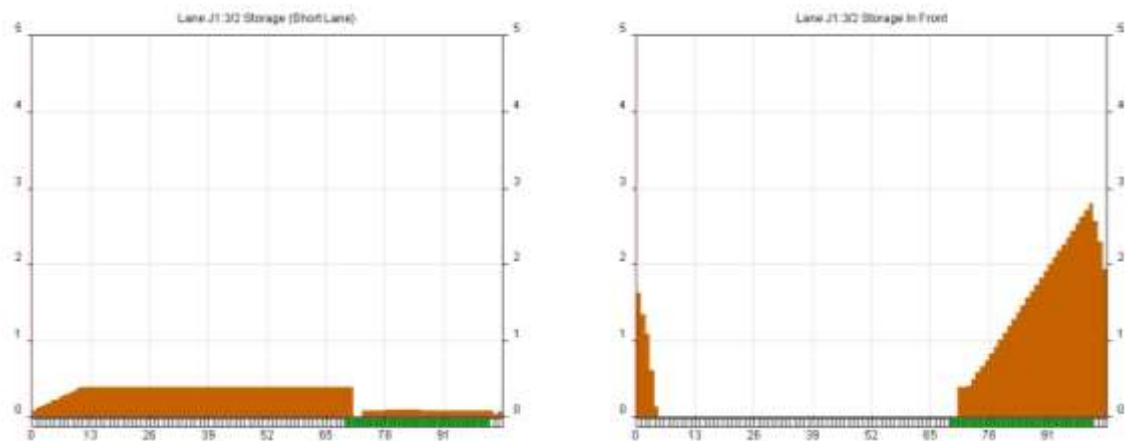

Figure 80: Example of storage graphs in LinSig

4.7.3 Travel Time / Delay Matrix View

LinSig provides details of average travel times between Zones in the modelled network. The travel times included within the matrix are:

- **Average Journey times (s)** – travel time between Zones, a weighted average is provided where there is more than one Route between Zones;
- **Average Undelayed Time (s)** – travel time between Zones, without including delay caused by queuing; and
- **Average Delay per PCU (s)** – the average queue delay encountered by traffic travelling between Zones.

This information can be provided whether Lane-Based or Matrix-Based flows have been applied, and results can be differentiated by routed traffic or by Flow Layer. While reported journey times and delays should be broadly representative for Matrix-Based flows, these values should be treated with caution when using Lane-Based flows. In the latter case the results represent summed average values for traffic on each Lane along the route and is not restricted to traffic travelling between the origin and destination zones. For Lane-Based flows the travel time matrix therefore does not account for differing arrival profiles from upstream lanes and coordinated signal offsets that may benefit some routes over others.

It is recommended that a microsimulation model is used for reporting journey time results. However, if indicative journey time outputs are required from LinSig it is recommended that Matrix-Based flows are used and routing information is based on OD surveys or a tactical model.

4.7.4 Report Builder

The Report Builder allows various LinSig modelling information to be extracted and presented in a customisable manner, either for direct analysis or further editing in word processing software. Such information can include graphical views of almost any of the LinSig program views (including junction layout, stage views / sequences, signal timings and interstage timings) or data in tabular form such as input data or model performance statistics.

4.7.5 Model Audit View

LinSig has a Model Audit View, where all model input data and results are displayed in a tabular format to assist when reviewing model data. The report is not automatically updated when changes are made within the model, and the Model Audit View window will require refreshing to ensure all data is up to date.

The Model Audit View also has a facility to compare two Scenarios, which can be in separate LinSig files. This shows a comparison of the input data and model results for the specified Scenarios, with changes between them highlighted with both values indicated, as shown in **Figure 81**. This is a useful view for auditing LinSig models when identifying key changes between model submissions.

The screenshot shows the LinSig Model Audit View interface. It is divided into several sections:

- Network Layout:** A table showing lane data for a specific network. Columns include Lane Name, Lane Length, Start, Lane Width, Lane Type, Substation, Flow, etc.
- Lane Data:** A comparison table between two scenarios. The columns are: Lane Name, Lane Length, Start, Lane Width, Lane Type, Substation, Flow, etc. The table shows differences between the two scenarios, with values highlighted in red and blue.
- Change in Front-Of-Stopline:** A table showing the change in front-of-stopline data between two scenarios. Columns include Lane Name, Area, Start, End, etc.

Figure 81: LinSig Model Audit View, highlighting differences between two compared files

5 Highway Traffic Assignment

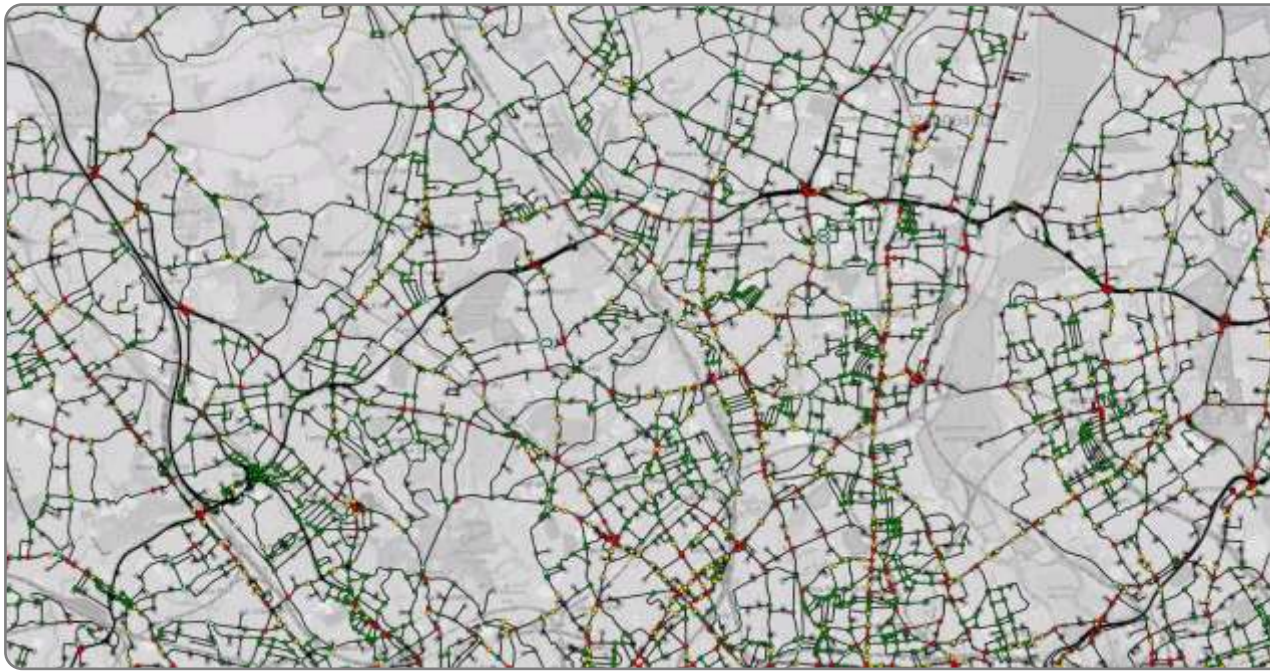

5.1 Introduction

In this chapter Highway Traffic Assignment (HTA) is used to describe a distribution of travel demand (trips) on a supply network, where a travel cost equilibrium state is achieved. HTA therefore identifies a set of likely routes among Origin-Destination (OD) pairs and estimates flows such that no vehicle can find a better generalised travel cost by switching its route.

HTA can be classified according to the technology used to derive travel times / delays:

- **Macroscopic** – uses analytical formulae;
- **Mesoscopic** – uses simplified simulation of individual vehicles; and
- **Microscopic** – uses detailed simulation of individual vehicles.

HTA can be classified according to the spatial application scale:

- **Local Area** – typically a small subnetwork; and
- **Global Area** – for example the whole urban area (this category is sometimes called strategic).

HTA can be classified according to the assessment time horizon:

- **Tactical** – short term assessment; and
- **Strategic** – long term assessment.

Theoretically one can have a Local Area Macroscopic HTA model (for example using Visum's Intersection Capacity Analysis (ICA)) or a Global Area Microscopic HTA (for example using Vissim dynamic assignment) model. However, the former is considered to be over-simplification (as a more realistic model can be built easily) and the second one is over-complication given that it would be hard to create and to run.

5.2 Use of HTA Models in TfL

The use of HTA models within TfL is separated into two categories based on the time horizon being modelled. The two categories are defined by TfL as Strategic and Tactical and are described in the following sections. Both the strategic and tactical models are based on macroscopic assignment methodology.

5.2.1 Strategic HTA Models

The Strategic HTA suite predicts the overall demand and the demand responses in London and provides a strategic assessment of transport infrastructure and policy changes. Strategic HTA models can be summarised as follows:

- Have a long-term planning horizon, beyond five years;
- Support planning to meet London's future transport needs;
- Help TfL make key transport investment decisions; and
- Identify the most effective transport interventions for meeting the goals set out in the Mayors Transport Strategy.

TfL's strategic demand model, Model of Travel in London (MoTiON), uses land use assumptions, economic and travel behaviour assumptions and planned transport investment to forecast the total number of trips made, what mode they will use, travel times and determine crowding and congestion. Integrated into MoTiON are the following assignment models: London Highway Assignment Model (LoHAM), Railplan and Cynemon, as shown in **Figure 82**. For further information, contact StrategicModelling@tfl.gov.uk.

5.2.2 Tactical HTA Models

TfL's tactical modelling suite, enables a detailed operational assessment of the network and can provide information back to TfL's strategic modelling suite in terms of the actual capacity available on the road network. Tactical HTA models can be summarised as follows:

- Having a shorter-term planning horizon, of three to five years;
- Replicating real-life conditions to test proposed schemes and predict outcomes;
- Providing flow and routing information for microsimulation models;
- Supporting operational decision-making by providing those running the network with a balanced and impartial viewpoint; and
- Enabling effective mitigation strategies.

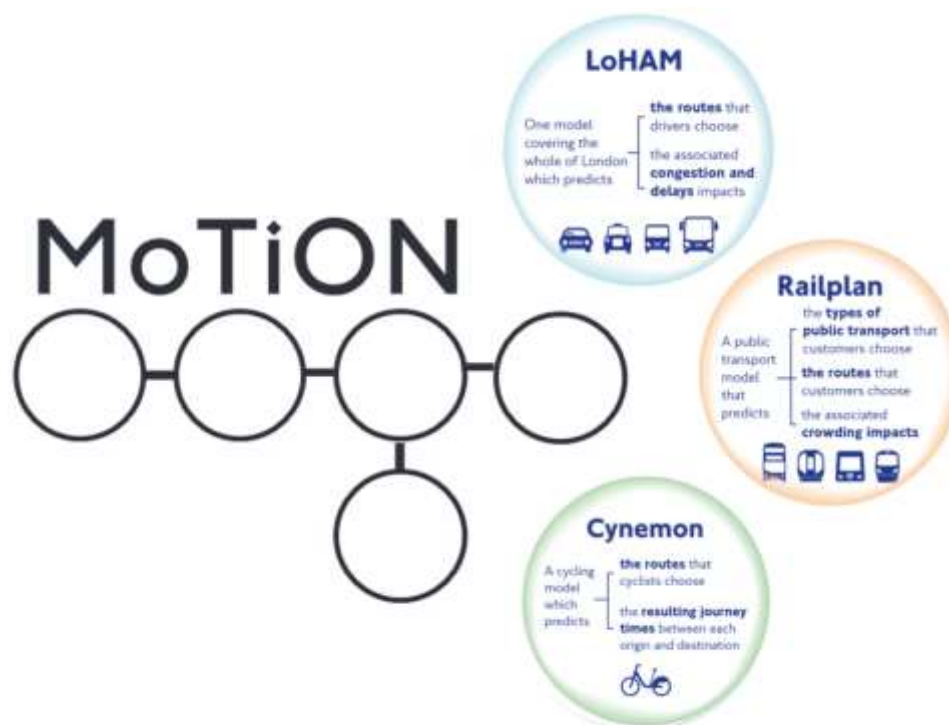

Figure 82: TfL's MoTiON Model

The tactical HTA model used by TfL is called the Operational Network Evaluator (ONE) model. It is used to predict short term global traffic reassignment and congestion impacts due to local network changes.

Assessing the global implications of local network changes, such as improvements to junction layout or signal timings, requires detailed transport network representation and assignment methods capable of estimating congestion effects with high realism. At the time of publishing, the ONE model represents AM and PM peak periods. For further information, contact ONE@tfl.gov.uk.

This chapter provides advice for the development of tactical HTA models and for model application in an operational scheme assessment context and augments the general modelling guidance provided in Chapter **B2** on **Modelling Principles**. However, there may be cases where local conditions or project requirements dictate the use of methods which may be different to those outlined. In these situations, NP should be consulted on the planned methodology.

5.3 Traffic Assignment Requirements

To represent congested conditions realistically it is important that the chosen tactical modelling software meets specific criteria:

- Accurate representation of capacities for signal controlled and priority junctions taking into account the impact of conflicting traffic streams;
- Realistic estimation of travel times (including delays) on links and junctions due to traffic control and conflicting traffic streams;
- Realistic estimation of queues and associated blocking back effects on upstream movement flows; and
- Assignment algorithm should enumerate a realistic set of alternative routes between origins and destinations, model route choice taking into account congestion effects, as well as converge, and produce stable outputs in a reasonable amount of time.

The software commonly used for tactical modelling includes Aimsun Next, SATURN and Visum.

5.3.1 Mesoscopic Models

HTA algorithms have advanced significantly to make simulation-based dynamic assignment methods practically (computationally) feasible for large scale urban networks. These methods are conventionally referred to as mesoscopic assignment.

Mesoscopic assignments are based on the conventional least cost equilibrium principles and employ simplified simulation of individual vehicles aimed at providing more detailed and realistic representation of travel times at junctions and along links.

Mesoscopic models use similar algorithms to those used in microsimulation models, such as car following, gap-acceptance and weaving. Mesoscopic assignments generally aim to provide more detailed representation of vehicles at intersections and adopt simplified car-following models along links. The aim is to represent the dynamic movement of individual vehicles through the network, rather than aggregate averages of traffic volumes as in a strategic or tactical model. Furthermore, in a mesoscopic assignment the demand and supply can be represented dynamically using a finer resolution time series.

Potentially there are more challenges in terms of convergence and run times of the simulations when using mesoscopic models. The advantages for mesoscopic models versus strategic or tactical models are the simplification of microsimulation modelling over a much bigger area with traffic behaviour and vehicle interactions represented.

At the time of publication, a new generation ONE model is being developed with the aim of incorporating a mesoscopic assignment methodology. Once considerable experience is gained through development and use, this section will be updated with advice pertaining to mesoscopic assignment models.

5.4 Preparation

General guidance on Base model development is provided in [B2.3](#) and [B2.4](#). This section provides specific guidance for preparing to develop or use a tactical model.

5.4.1 Model Boundaries

The modelled area in a tactical model is defined by identifying the area within which traffic flows or journey times are likely to experience a significant change as a result of implementing the scheme or intervention. The extent of the modelled area should be agreed with the stakeholders at the model application scoping stage. Tactical models should include all important highway links and junctions within the area of influence of the scheme to enable a more robust modelling of travel times, routing and assignment to be achieved.

The density of the network differs in accordance to its vicinity to the scheme, containing a higher level of detail for the area closest to the scheme in question, with a declining level of detail further away. The simulation area should also have a detailed zoning system for traffic demand.

The remaining areas in the model are where the impacts of interventions are considered to be relatively weak in magnitude, specifically at junction interaction level. See section [B5.5.2.1](#) for further guidance.

5.4.2 Data Collection

Prior to building a tactical model the following information should already have been obtained, as identified in sections **B2.2** and **B2.3**:

- Topography of highway network, this can be obtained from a reliable and up-to-date mapping database (for example the Ordnance Survey Master Map Integrated Transport Layer);
- Classified turning counts, at a junction level and at the start and end of trips;
- Traffic demand matrices (section **B5.5.1**);
- Bus routes and frequencies;
- Bus stop locations;
- Signal timings, normally supplied from validated deterministic models;
- Saturation flows, normally supplied from validated deterministic models;
- Vehicle journey times; and
- Mandatory speed limits.

5.4.3 Model Time Periods

An appropriate modelled peak hour should be defined by investigating the traffic levels across the peak periods, based on available traffic demand data. General guidance on model time periods is given in **B2.3.3**.

The tactical modelling suite held by M&V have the following peak periods modelled:

- AM peak: 08:00 – 09:00; and
- PM peak: 17:00 – 18:00.

5.5 Base Model Calibration

Following the collection of model input data, it can be used to build and calibrate a tactical assignment model. A calibrated tactical model should have as a minimum:

- Accurate representation of capacities for signal controlled and priority junctions taking into account the impact of conflicting traffic streams;
- Accurate representation of junction geometry and link attributes; and
- Realistic estimation of travel times (including delays) on links and junctions due to traffic control and conflicting traffic streams.

5.5.1 Travel Demand

This section details the different elements that comprise the Transport Demand within a tactical assignment model.

5.5.1.1 Travel Demand Data

This guidance refrains from giving advice on travel demand development and assumes that reliable matrices representing travel demand by user class are available and ready to be used within a tactical model. Travel demand matrices could be obtained from travel demand models that utilise a wide range of data sources, such as TfL's strategic demand model, MoTiON (section [B5.2.1](#)).

M&V advises differentiating at least four user classes: cars, light goods vehicles, heavy vehicles and taxis, where heavy vehicles include all private vehicles larger than light goods vehicles. This minimum set of user classes is justified by significantly different travel patterns, differences in the value of time and different preferences in route choice. It is important to ensure that all required user classes are differentiated when requesting traffic surveys.

5.5.1.2 Zones

Zones describe the position of origins and destinations of trips within a tactical model, representing residential areas, shopping centres, schools and car parks for example. Generally, the zoning system should be defined taking into consideration relevant administrative boundaries, the demand model zoning system that the tactical model is linked to, as well as the level of mobility taking place in particular areas. Higher mobility density leads towards smaller zone sizes. As a guideline, zones should be small

enough to have no more than 200-300 trips arriving and departing to / from a zone.

5.5.1.3 Connectors

A connector is a special type of link that connects a zone to a node / junction in the road network. It represents the point or points at which all traffic accesses the network. Connectors should be coded realistically and, where possible, represent actual means of access to and egress from the modelled network such as a car park or side road. It is advisable that connectors do not connect directly into a junction, connectors should use secondary links or nodes to account for the access / egress arrangements to the road network.

The number of connectors for each zone should be minimised, where possible limited to one connector per zone. Connectors for neighbouring zones should not load on to the same node / junction. Refer to Traffic Analysis Guidance (TAG) for a more detailed practical advice on this topic⁷⁵.

It is advised that network connectors are reviewed to avoid queuing on the connector itself. The presence of queues on the connectors would result in an underestimation of the demand entering the road network.

5.5.2 Network

The model network of a tactical model forms the transport supply component of Highway Assignment. This section details the different elements that comprise the Transport Supply network.

5.5.2.1 Buffer Network

In tactical models there are two levels of network details, the key area (simulation) and buffer network. The buffer network is a skeleton network that feeds demand into the key area without detailed junction representation. The simulation provides accurate information of the junction operation including the signal timings (section **B5.5.2.3**). The buffer network, surrounding the simulation area, represents the roads as opposed to the junctions. It is coded in very coarse detail as it is only a source for external trips to or from other regions in the wider extent of the network to enter or leave the model. The buffer network also allows the tactical models to cover a much wider network than the key area. The feeder buffer network is fully integrated with the key model area as an assignment network.

In different software packages the buffer network is also known as the external area or wider area.

5.5.2.2 Links

Any complex original dataset needs to be reduced to a manageable set of links on which the assignment is to be performed. However, it is important to retain all non-local links and 'rat runs' that play an important role in travel route choice both in the Base situation and in relation to the proposals.

Network data sources typically contain attribute information detailing functional class, speed limits and number of lanes which are automatically loaded into a model, however, these networks often need to be verified against independent data sources to ensure their accuracy.

Link speeds entered in the model are assumed to be constant throughout the length of the links and equal to their speed limit (or alternatively free-flow speed measured using a moving observer method during uncongested conditions).

The number of lanes on a link represents the number of through lanes between the two nodes connected by the link. Where flares exist, these can be accounted for on a node level.

Unrestricted speeds and number of lanes must be verified, either using up-to-date aerial overview applications such as internet mapping services or undertaking site visits.

Where bus lanes exist along a link, care must be taken to represent their operation accurately, especially where operation hours vary throughout the day. Subject to local traffic regulations, bus lanes usually create additional capacity not only for buses but for taxis as well. Bus stop locations and dwell times should be replicated and linked to relevant bus routes.

5.5.2.3 Nodes

Junctions are dominant sources of delay in congested urban networks. It is therefore critical that junctions are coded accurately, and that the modelling software correctly simulates the operation and capacity of junctions. Different tactical modelling software packages simulate junction capacity using different methods; however, it is common that junction attributes will include data that defines junction geometry and the average method of traffic control.

The coding of geometric elements should represent information obtained from various sources such as site layout diagrams and site observations. These allow for the specification of the number of lanes per approach, permitted turns and the effective flare lengths⁷⁶. Software packages usually provide a mechanism to define prohibited movements by user class.

It is recommended that U-turning movements are not included at nodes within tactical models, this ensures realistic routing choices are made and to ensure that the number of calculations undertaken during the assignment procedures are minimised.

5.5.2.3.1 Signal Controlled Junctions

In congested urban networks signal controlled sites are very frequent and precise coding is of paramount importance. Detailed representation usually encompasses several elements such as the definition of phases (including allocation to lane turning movements), stages, interstages (including intergreens and phase delays), and stage sequences, as well as the coding of representative cycle times and stage durations. Depending on the assignment model, the discharge rate may be governed either via saturation flows or other means (such as a car following model). Opposed right turning movements may require additional gap acceptance parameters to be applied at the node level.

Within tactical models, due to the average peak hour representation of the traffic conditions, only a typical signal cycle is reflected. Therefore, the signal timings should be manually adjusted in order to replicate the impact of demand-dependent stages on phase green times. The use of validated deterministic models, such as LinSig and TRANSYT, can assist with the correct interpretation of phase-based signal timings as the following will already have been accounted for: demand dependency, underutilised green time (UGT) and phase delays. Where the tactical modelling software takes

76 The effective length of a pocket lane (flare) is the position at which the flared approach allows two vehicles to queue side by side

account of blocking back, timing adjustments, such as UGT, that have been included in the deterministic modelling to reflect this, do not need to be transferred into the tactical model. However, it is important to check that the cause of the UGT is not caused by factors other than blocking back before adjusting the timings (section **B2.3.10.1**). Therefore, any green time adjustments for UGT should only be included if the cause is at the junction being modelled and not by a downstream junction. It is advised that when signal timings are taken from validated deterministic models, 1 second of effective green is added when coding timings to ensure realistic representation of signal operation. Where the software allows, the capacity of turning movements can be accurately reflected by using saturation flow information from validated deterministic models.

5.5.2.3.2 Priority Junctions

The layout of priority junctions is modelled with the same level of detail as signal-controlled junctions. In most software packages, the capacity of priority junctions is estimated via junction geometry and the gap acceptance parameters of traffic exiting the side road. In some software packages, it is possible to amend the parameters governing capacity values at priority junction movements, these parameters are known as 'critical gap' and 'follow up gap' or 'GAP'. The critical gap defines the temporal distance between two successive vehicles in the main flow that a vehicle on a side road requires to enter the main flow. Follow-up time defines the additional time required for a second vehicle to accept a gap in the opposing traffic. This parameter indirectly defines saturation flows.

Where the software allows, it is important that the major traffic flow at a priority-controlled junction is accurately specified. This allows for the correct calculation of the gap acceptance parameters and capacity of the approaches.

5.5.2.3.3 Roundabouts

The approach used to code roundabouts in assignment models is dependent on the size of the roundabout. The different approaches are discussed in the following sections.

Large roundabouts, generally with a diameter greater than 40m, are modelled as a series one-way links and either signal or priority-controlled nodes depending on the operation of the roundabout. The approach and exit lanes for the roundabout are modelled using a single lane. This method of coding allows link lengths of the gyratory to be included within route choice during the assignment process.

Roundabouts at major or grade separated junctions are modelled in a similar way, however the approach and exit lanes are modelled separately.

The approach lanes should be attached to signalised or priority-controlled nodes as appropriate, with the exit lanes leaving the circulating carriageway using an unspecified node (section **B5.5.2.3.4**). Where a slip road exists at a roundabout, allowing vehicles to move through the junction without having to stop and give way to opposing traffic, a link is coded alongside the circulatory to allow this movement to avoid the roundabout.

At small priority-controlled roundabouts, delay is calculated using the Kimber / TRL method which requires detailed geometric information for each approach arm⁷⁷. The geometric information required includes entry width, flare length and approach width. These are the same measurements that would be required for other roundabout junction modelling software, such as ARCADY.

5.5.2.3.4 Unspecified Nodes

Unspecified nodes are used in all software packages to represent changes to link attributes which do not impact on capacity or there is no interaction between vehicles. In different software packages these are known as Dummy or Unknown nodes.

5.5.2.3.5 Main Nodes / Junctions

Complex and/or large junctions (such as dual carriageway junctions) are often not represented by a single node, but instead by a group of nodes. One individual node then corresponds to only one part of an actual junction, which could result in erroneous modelling results. To resolve this issue all nodes comprising a given intersection are grouped into a single main node / junction.

Main nodes may also be used where there are banned movements between closely located junctions, for example where only traffic from certain approaches at an upstream junction can make a turning movement at a downstream junction due to lane allocation or physical barriers.

In different software packages these are known as spider nodes or Supernodes.

⁷⁷ Kimber, R M (1980). "The traffic capacity of roundabouts", Department of Environment Department of Transport, TRRL Report LR 942: Crowthorne: Transport and Road Research Laboratory

5.5.3 Public Transport

Public Transport services in tactical models are incorporated as fixed demand, also known as a pre-load. The main considerations are the frequency of buses and the number of routes on specific links. Bus pre-loads should be based on the on-street timetables and added to the highway network on a link-by-link basis for each modelled time period. The bus pre-load is considered during the highway assignment, whereby the pre-load is multiplied by a PCU factor and subtracted from the link and turn capacity. This accounts for the loss of capacity due to presence of the public trips on the network.

5.5.4 Cyclists

It is important to identify the key cyclist volumes for inclusion in TfL's tactical models due to the increasing prevalence of cycling in London. Cyclists are only considered in the tactical model for their impact on motorised traffic, and therefore only included where limited or no segregation is present between cyclists and motorised vehicles.

Similarly to public transport, cycle flows are imported into tactical models as static pre-load onto link volumes in each time period. This reduces the available link capacity for motorised traffic. A suitable conversion factor should be used to convert cycle flows to PCU units for tactical model assignments.

This implementation is independent of the software chosen and motorised traffic is impacted by the link volume / delay functions, resulting in reduced speeds and restricted volumes due to the presence of cyclists on the road.

Cycle demand information can be obtained from the CYNEMON model, as described in section [B5.2.1](#) and [Figure 82](#).

5.5.5 Calibration Tools

Tactical modelling software packages supply functionality facilitating network integrity checking tasks. This includes as a minimum:

- Connectivity test, which ensures the existence of routes between all OD pairs; and
- Redundant elements test, which ensures that model does not contain isolated network elements such as nodes or links.

These automated tests should follow manual network layout and traffic control checks and generally work as an additional inspection layer.

Once confidence in network accuracy is established, the enumerated routes and travel demand distribution are checked to see if they are reasonable.

Route choice in the model can be examined, by using tools available in the software packages:

- Visualisation of minimum cost routes between OD pairs;
- Visualisation of enumerated routes and volumes between OD pairs; and
- Visualisation of enumerated routes and volumes on links (such as in select link analysis).

5.5.6 Matrix Estimation

Having designed a network structure and sensible set of routes, it may be necessary to calibrate prior trip matrices by means of matrix adjustment. OD pairs whose values are derived from road-side interviews and are deemed to be reliable should be frozen during matrix calibration.

TAG⁷⁸ emphasises that count constraints in matrix estimation should generally be applied at the short screenline level as the mismatch between modelled flows and counts at any one location (individual site) may be due to a number of reasons and not due solely to deficiencies in the trip matrices. Employing constraints at individual sites is likely to exacerbate the tendency of the matrix estimation procedure to compensate for deficiencies in other aspects of the model (zoning system, network structure, centroid connectors, and route choice coefficients).

As the primary purpose of matrix estimation is to refine estimates of trips that have been synthesised as opposed to being intercepted in surveys, screenlines independent of the roadside interview screenlines are required. In addition, screenline counts used as constraints in matrix estimation should be derived from representative ATCs with the vehicle type proportions being obtained from MCCs or other reliable means.

Initially, prior trip matrices are checked by comparing modelled flows and observed screenline counts. A matrix estimation procedure follows if the discrepancies are deemed significant and matrices may potentially fail the validation requirements. TAG⁷⁹ recommends monitoring the changes brought about by matrix estimation by the means identified in **Table 10**.

78 TAG Unit M3.I, 2020, Section 8.3.6, pp 36

79 TAG Unit M3.I, 2020, Section 8.3, pp 36 – 38

Table 10: Matrix estimation monitoring

Monitoring Method	Acceptability Criteria
Scatter plot of matrix zonal cell values, prior to and post matrix estimation, with regression statistics (slopes, intercepts and R ² values)	<ol style="list-style-type: none"> 1. Slope between 0.98 and 1.02 2. Intercept near zero 3. R² in excess of 0.95
Scatter plot of zonal trip ends, prior to and post matrix estimation, with regression statistics (slopes, intercepts and R ² values)	<ol style="list-style-type: none"> 4. Slope between 0.99 and 1.01 5. Intercept near zero 6. R² in excess of 0.98
Trip length distributions, prior to and post matrix estimation, with means and standard deviations	<ol style="list-style-type: none"> 7. Means within 5% 8. Standard deviations within 5%
Sector to sector level matrices, prior to and post matrix estimation, with absolute and percentage changes	<ol style="list-style-type: none"> 9. Differences within 5%

Changes falling outside acceptability criteria are deemed as significant and should be examined and assessed for their importance. After matrix calibration is complete, differences between modelled flows and counts on calibration screenlines should be reported.

5.6 Convergence Criteria

High levels of convergence should be achieved in tactical models. With poor assignment convergence, there is little confidence in typical modelled outputs, examples of which include link flows and travel costs. Strong convergence indicators also provide confidence that any differences in modelling outputs between Base and Proposed networks can be attributed to the effects of the scheme being tested rather than to uneven degrees of convergence (model noise).

Concerns regarding convergence are discussed in detail in TAG, on which TfL practice relies significantly. M&V believes that convergence in practice needs to be measured in terms of two desirable properties:

- Proximity to the assignment objective (such as Wardrop equilibrium); and
- Stability of the model outcomes between consecutive iterations.

Proximity indicators measure the degree to which the assignment has achieved its stated mathematical objective. In the case of equilibrium assignment this means the degree to which Wardrop's equilibrium has been achieved.

There are two types of stability indicators that measure the change between consecutive model iterations:

- Aggregate stability indicators, that provide network-wide comparisons of parameters such as total costs, distances, times and average speeds; and
- Disaggregate stability indicators, which provide Link-Based comparisons of typical parameters such as flow, cost and time.

TAG recommends the convergence measures detailed in **Table II** are to be used when developing a Base model⁸⁰.

Table II: Convergence indicators from TAG⁸⁰

Measure of Convergence	Base Model Acceptable Values
Delta and %GAP	Less than 0.1% or at least stable with convergence fully documented and all other criteria met
Percentage of links with flow change (P) $<1\%$	Four consecutive iterations greater than 98%
Percentage of links with cost change (P2) $<1\%$	Four consecutive iterations greater than 98%
Percentage change in total user costs (V)	Four consecutive iterations less than 0.1%

It should be noted that each specific tactical modelling software adopts different principles for measuring convergence. The criteria should be interpreted in the context of the application of the models. It is recommended that the TAG guidance is followed, but alternative convergence indicators could be accepted following detailed justification.

In conclusion, both stability and proximity criteria should be satisfied for four consecutive iterations before convergence can be judged to be acceptable. These values should always be reported, and any deviations explained with a reasoning behind any poor convergence performance.

5.7 Base Model Validation

Model validation data must be independent from data used during calibration. This data independence ensures that validation statistics are a true measure of validation. It is not appropriate to supplement validation data with data used during calibration in order to improve the quality of model validation. A Validation Report should document validation results for matrices and assignment.

5.7.1 Matrix Validation

Matrices are validated using an independent set of validation screenlines that are different from those used in roadside interviews and matrix calibration. TAG recommends that differences between modelled flows and counts should be less than 5% on all or nearly all screenlines⁸¹.

5.7.2 Assignment Validation

The validation of the traffic assignment within tactical models has separate criteria for the validation of traffic flow and journey times. The criteria are detailed in the following sections. In addition, checks should be carried out to ensure there is a realistic estimation of queues and associated blocking back effects on upstream movement flows.

5.7.2.1 Traffic Flow Criteria

Generally, traffic flows can be validated on a link or turning movement basis. TAG points out that it is rare that turning movements will have been counted using automatic methods over a number of days⁸²; most likely, the available or affordable counts will be single day MCCs. For this reason alone, turning movements may not validate to the standards achieved for link flows. Nevertheless, both Turn-Based and Link-Based modelled flows and counts should be compared and assessed using criteria and acceptability guidance given in **Table 12**.

Model performance in terms of these validation acceptability criteria should be reported for each modelled user class and each time period.

81 TAG Unit M3.I, 2020, Section 3.3.7, pp 19

82 TAG Unit M3.I, 2020, Section 9.3.2, pp 39

Table 12: TAG traffic flow validation criteria

Criteria	Description of Criteria	Acceptability Guideline
1	Individual flows within 100veh/hr of counts for flows less than 700veh/hr	> 85% of cases
1	Individual flows within 15% of counts for flows from 700 to 2,700veh/hr	> 85% of cases
1	Individual flows within 400veh/hr of counts for flows more than 2,700veh/hr	> 85% of cases
2	GEH < 5 for individual flows	> 85% of cases

5.7.2.2 Journey Time Validation

The validity of an operational tactical model should be assessed by comparing the model travel times against on-site observations on a selected set of routes. The routes for the validation of journey times should cover the modelled area as evenly as possible and include the most critical links and junctions. TAG points out that the validation routes should not be excessively long (greater than 15 km) nor excessively short (less than 3 km) and should not take longer to travel than the modelled time periods⁸³.

These comparisons will demonstrate how well link travel times and junction delays are represented, which is of paramount importance in accurate tactical models.

TfL recommends the journey time validation requirement given in TAG, that 85% of all validation route journey times to be within 15% of observed mean times for the full length of route⁸⁴. This is generally demonstrated by generating observed and modelled travel time plots along the journey time validation routes.

83 TAG Unit M3.1, 2020, Section 4.3.3, pp 26

84 TAG Unit M3.1, 2020, Section 3.3.15, pp 21

It is worth reiterating that good quality data is required for model validation. The accuracy (half of 95% confidence interval or 1.96 of standard error) of observed counts must be within a GEH of two of the mean value. The accuracy (half of 95% confidence interval or 1.96 of standard error) of measured travel times must be within $\pm 10\%$ of the mean value. An assessment of the accuracy of the data is only possible where the information has come from automated collection sources such as ATCs for counts and GPS tracked vehicle data for travel times.

5.8 Proposed Model Development

Proposed models should be created by amending the validated Base model or in the Future Base model, if following the Three Stage Modelling Process, to include the scheme proposals. These changes should be made by only making changes to the elements of the model that are modified due to the scheme, as outlined in **B2.5**.

This section deals with items which particularly need to be considered when building a Proposed tactical model.

5.8.1 Future Base

As described in **B2.5.1**, the Future Base model includes all likely network changes which will occur between the Base year and the year being examined in the proposal, excluding the scheme under consideration. It is built from the validated Base tactical model by modifying as little as possible in relation to all schemes likely due to be implemented prior to Future Base year.

TfL have Future Base tactical models available which include multiple schemes due to be implemented by the Future Base forecast year. However, it is advisable to make sure the schemes included are updated to include the latest information available at the time of the model build, including any additional schemes, especially in the vicinity of the scheme to be assessed.

The guidance in this section applies to creating the Future Base model as well as to the Proposed scenarios.

5.8.2 Traffic Demand

There may be a requirement to amend the travel demand used in the tactical model to reflect the estimated changes in demand for the Proposed year. This can be achieved by applying an agreed factor to the demand matrices used in the Base model. The factoring of demand flow is often influenced by TfL's strategic HTA models (section **B5.2.1**).

If the scheme under consideration is anticipated to significantly impact highway travel costs, the traffic demand matrices for all user classes may need revisiting as a result of possible modal shift. An iteration process between tactical and strategic HTA models would be required to refine the demand matrices to be used in the Proposed models.

5.8.3 Signal Timings

Proposed signal timings should be provided from deterministic models that have been updated to represent the scheme proposals. Initially, the signal timings in the deterministic models will be optimised based on Base model or Future Base model traffic flows, or with manual assumptions of traffic reassignment. It is therefore recommended that an iteration process is undertaken, where tactical model traffic flows are transferred to deterministic models, then the signals are re-optimised and the resultant signal timings are fed back to the tactical model for assignment until the assignment flows in the tactical models stabilise.

Where demand dependency and UGT have been replicated in the supporting deterministic models, consideration should be given to including these in the tactical model signal timings. Where the tactical modelling software takes account of blocking back, any UGT that has been reflected in deterministic models for this purpose does not need to be replicated in the tactical model. However, the cause of the underutilised green time should be carefully checked and any green time adjustments for UGT should only be included if the cause is at the junction being modelled and not by a downstream junction. The inclusion of signal timing adjustments for demand dependency in a Proposed model should be considered on a scheme basis, taking account of what might reflect the worst-case scenario for that scheme. For further guidance refer to section **B2.5.2.3**.

5.8.4 Saturation Flows

Where the software allows, the capacity of turning movements can be updated using saturation flow information from Proposed deterministic models. Saturation flows should only be changed from the Base model if there is clear evidence that they would be different in the Proposed scenario

5.8.5 Public Transport

Where proposals include any changes to bus routes, individual routes should be appropriately reallocated in the tactical model. Where new bus stop locations are required it is important to include appropriate dwell times for each route, it may be appropriate to determine dwell times from adjacent or relocated stops. The removal or addition of bus lanes should be applied on a link level.

5.9 Model Outputs

Tactical models can provide a variety of model outputs to aid in the analysis and reporting of scheme performance. In most cases this includes:

- Comparison of traffic performance statistics (average speeds, travel times and mileages for example) for aggregated areas such as boroughs;
- Comparison of traffic flows on links or turns; and
- Comparison of traffic routing between particular origins and destinations across the network.

Commonly data from tactical models can be extracted for use in other models, such as deterministic models, microsimulation models and Air Quality and Noise assessments.

5.9.1 Model Noise

When the model outputs are being used to compare scheme proposals, it is important to be able to distinguish differences due to the scheme being assessed from those associated with different degrees of convergence, known as 'model noise'.

Tactical models utilise an equilibrium assignment methodology, wherein it assigns trips between all origins and destinations to their least cost path and assumes that drivers have perfect network knowledge when selecting routes. At the outset the traffic model algorithm assesses, for each origin trip, all the possible route permutations to every destination, it then selects the lowest cost route and assigns trips through the network. This infers that the trip has perfect knowledge of the delays and congestion along each and every route and therein makes decisions about the lowest cost route before departing. Routing decisions will differ between the with and without intervention scenarios as a result of the changes made and the point at which a new route is chosen can be some distance from the changes themselves. Consequently, the impacts of reassignment can be dispersed over a large area, and evidence of 'model noise' might be observed.

Tactical models require a high level of validation in the area of influence and also for key strategic routes through the area. The model also needs to be sufficiently responsive to test a range of development and network related scenarios without these effects being lost in 'model noise'. Given the size of the tactical models, typically with in excess of 2000 zones and a simulation area covering wide areas, the magnitudes of scheme impacts

can often be of the same order as model noise, despite the extremely high degree of model convergence routinely achieved across the models.

TAG⁸⁵ states that before the results of any traffic assignment are used to influence decisions, the stability (or degree of convergence) of the assignment must be confirmed at the appropriate level. The importance of achieving convergence is related to the need to provide stable, consistent and robust model results.

6 TRANSYT Modelling

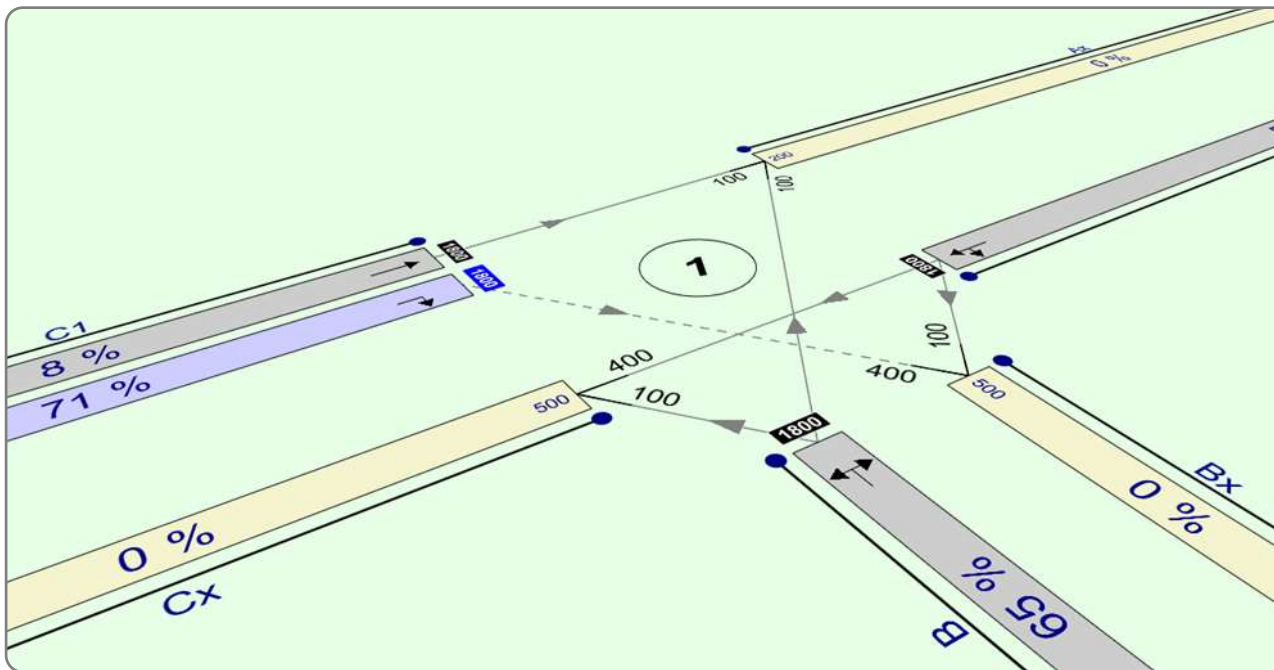

6.1 Introduction

This chapter is primarily intended to assist traffic modelling practitioners when building, auditing or otherwise using TRANSYT models as part of a scheme submission to TfL, typically under MAP. It augments the general modelling guidance given in Chapter **B2** on **Modelling Principles**.

Whilst this document outlines TfL recommendations in respect of TRANSYT modelling there will be cases where local conditions or project requirements dictate the use of methods which may be different to those outlined. In these situations, NP should be consulted on the planned methodology where modelling will be submitted for approval by TfL.

For more detailed explanations of specific TRANSYT features and functionality it is advisable to refer to the interactive help menus and TRL documentation supplied with the TRANSYT version being used, or consult the TRL Knowledge Base⁸⁶.

6.1.1 Introduction to TRANSYT

TRANSYT (TRAffic Network StudY Tool), produced by TRL, is a deterministic traffic modelling application that allows the optimisation of signal timings, to minimise the stops and delay experienced by road users while also

⁸⁶ <https://trlsoftware.com/support/knowledgebase/>

displaying performance metrics for assessment using indicators such as capacity utilisation and queue prediction. It is widely used within London, across the United Kingdom and globally for impact assessment of proposed schemes and for the initial preparation of signal timing plans prior to implementation.

6.1.2 Software Versions

The version of TRANSYT in most common usage within TfL remains TRANSYT I2 (henceforth referred to as T12), therefore much of the guidance contained in this document references this version.

The latest major version of TRANSYT released by TRL at the time of publishing is TRANSYT I6 (henceforth referred to as T16, and while this is not yet widely used within TfL an effort has been made to update guidance to reflect this version where possible. As T16 becomes more widely adopted it is anticipated that the content in this document will be updated as more experience is gained with this version. Intermediate versions between T12 and T16 are not directly covered in this document, although much of the content remains relevant.

Where significant content within this document is specific to a particular TRANSYT version, this is highlighted using the terminology below:

- [T12] – content is specific to TRANSYT I2; and
- [T16] – content is specific to TRANSYT I6.

6.1.3 Principles of TRANSYT

The mathematical evaluation and optimisation process within TRANSYT consists of two main components – a traffic model and a signal optimiser.

The traffic model predicts a Performance Index (PI) for a network based on an initial set of signal timing plans and traffic flows. The PI is a measure of the overall cost associated with congestion and delay and is a weighted combination of total vehicle delay and stops experienced by traffic within the modelled network. For convenience, it is expressed in financial units based on the cost of occupants' time for delay and vehicle running costs (fuel consumption and wear) for stops.

The signal optimisation component within TRANSYT iteratively modifies signal timings across the modelled network and assesses whether those adjustments have reduced or increased the PI. This process continues until an optimum set of signal timings producing a minimum PI is found, as illustrated in **Figure 83**.

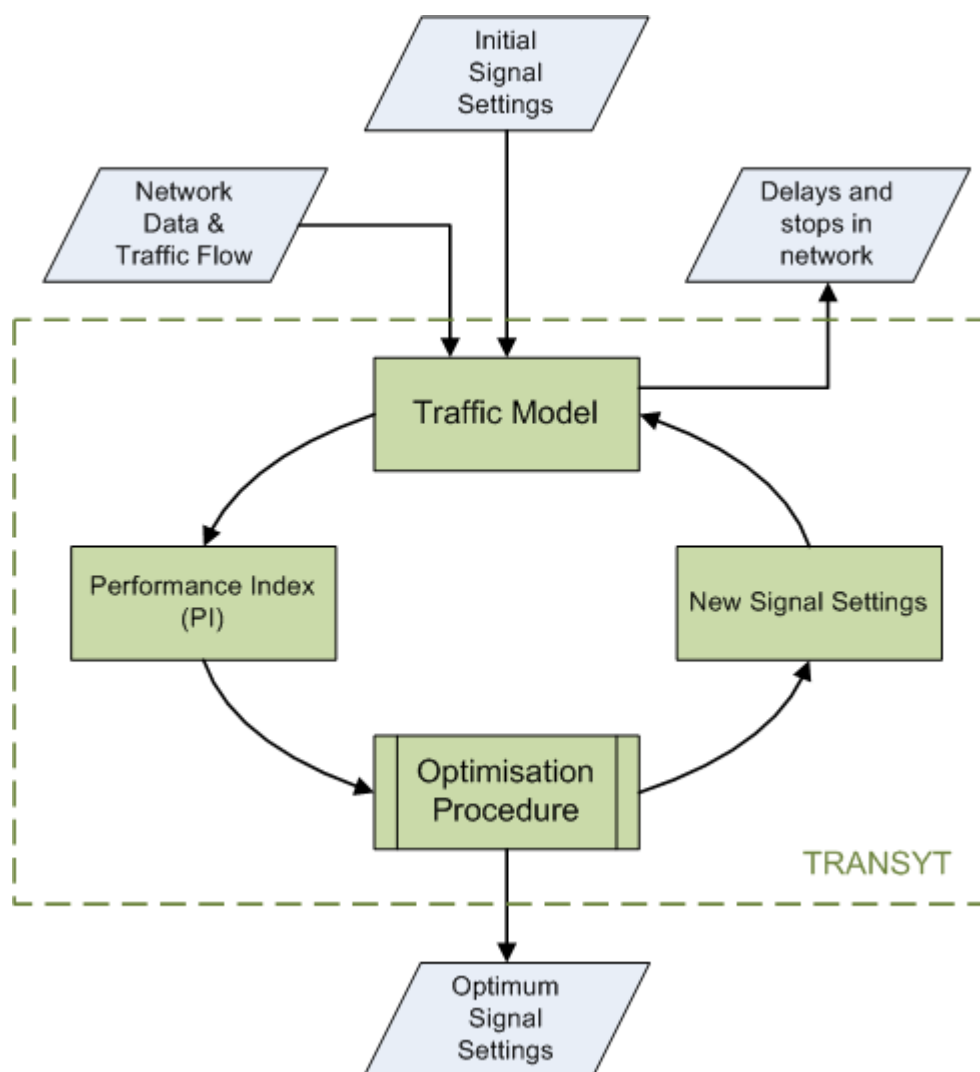

Figure 83: The TRANSYT optimisation process, adapted from the TRANSYT I2 user guide⁸⁷

6.1.4 Appropriate Use of TRANSYT

TI2 is appropriate for modelling coordinated networks of signalised neighbouring junctions based on a common cycle time. Priority junctions can also be included within a model, however this is only appropriate where they form part of a larger network comprised primarily of signalised junctions.

87 Binning J C, Crabtree M & Burtenshaw G, TRANSYT I2 User Guide, Application Guide 48 (Issue C), TRL, 2005

Tl6 can further include neighbouring signalised networks based on differing cycle times, and priority junctions can be more accurately modelled when not part of a larger signalised network.

When modelling networks, Tl2 is not capable of modelling the causal reasons for poor network performance such as exit-blocking, but this can be accounted for through manual adjustment of model input parameters based on site-collected data (section [B6.4.5.6](#)). Tl6 provides some ability to account for blocking effects when using the Cell Transmission Model or Simulation Model, however when using other models blocking effects need to be accounted for in a similar manner as for Tl2.

Where significant congestion is observed and leads to exit-blocking within a model, consideration should be given to the use of microsimulation modelling (section [A5.2](#)), to model both the cause and effect of pan-network exit-blocking.

6.2 Preparing to build a TRANSYT Model

Prior to building a model in TRANSYT the following information should already have been obtained, as identified in **B2.3**:

- Site Layout Drawings and SCOOT Link Diagram (if applicable);
- TfL Controller Specifications and Timing Sheets;
- Site-measured values for distances, cruise times, flare usage and saturation flows. Where measurement has not been possible, estimates should be used with appropriate justification (such as RR67 for saturation flows or extrapolated cruise times if conditions are permanently congested);
- Stopleveline traffic flows by turning movement;
- Determination of average signal timings, either from the UTC system or site measurement; and
- Site observation of traffic behaviour, particularly lane usage and effective flare length.

In addition to collecting the above data, skeleton LinSig models should be produced for all junctions to be modelled in TI2. This is necessary in order to verify correct controller phase representation (detailed further in **B4.1.3.2** and **B6.4.5.2**). This is not necessary for TI6 models since controller phases are directly modelled.

6.3 Graphical User Interface

The TRANSYT interface has changed over time and therefore varies significantly between versions. A brief overview is provided below describing the main elements and methods of interaction.

6.3.1 Network Visualisation

TRANSYT has built-in functionality that allows graphical representation of a network, using the Network Construction Editor (NetCon) in T12 or the Network Diagram view in T16. These also provide a convenient method for interaction with a TRANSYT model, both for data entry and visualisation of model results. **Figure 84** shows an example of the Network Diagram window in T16.

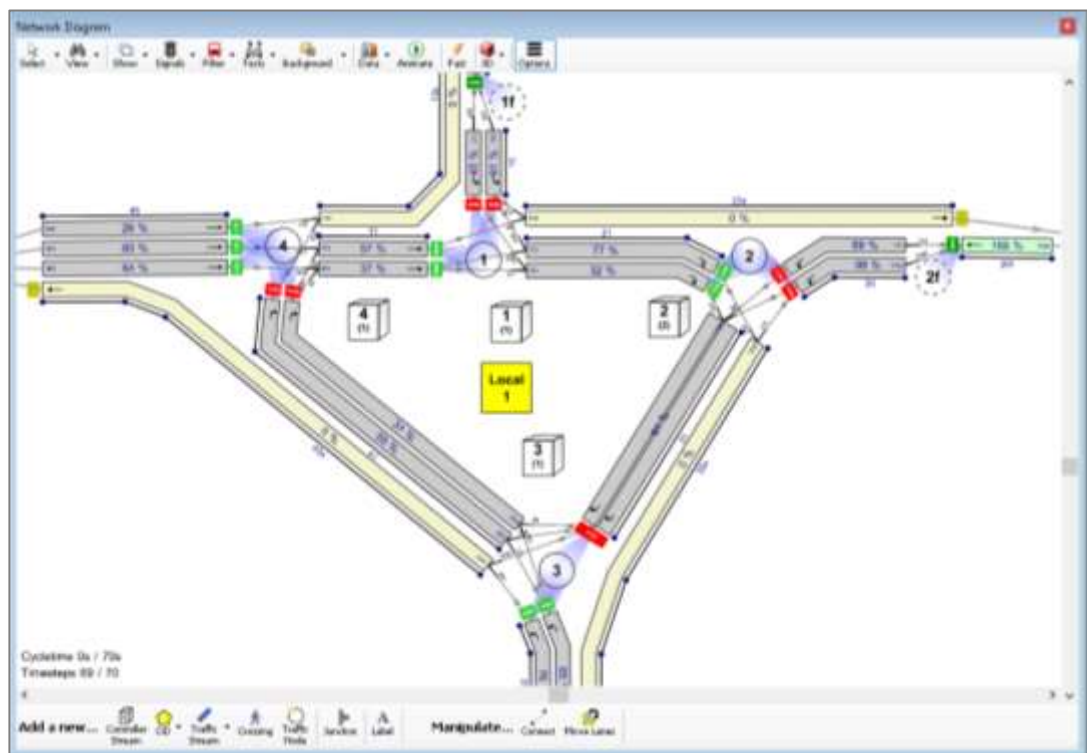

Figure 84: T16 Network Diagram window

6.3.2 TranEd interface to TRANSYT I2 ^[T12]

It is common for T12 models to be built using TranEd, a JCT software product that provides an alternative graphical interface to the underlying TRANSYT I2 program. The TranEd interface allows translation of controller phase information into TRANSYT I2 Link and stage data, and the network diagram to be coded graphically as part of the input file.

The TI2 content within this document applies equally whichever interface is used as the underlying functionality of TranEd is provided by TI2. No preference for either software interface to TI2 is expressed or implied within these Guidelines.

6.3.3 Data Input and Output Files

In TI2, input data is stored within a text-based (*.dat) file in logical groupings of related data referred to as Card Types, a historical reference to separate punched cards that were used with early versions of the program. Such references are used throughout the TI2 interface and in accompanying documentation.

In TI6, model data is stored within a proprietary (*.TI6) binary model file, which can only be accessed via the TI6 application. A number of Library File templates are provided for common intersection layouts in order to speed up initial model building tasks.

TI2 output data is contained within text-based (*.prt) files that are produced following TRANSYT runs. Basic TI6 output results are stored within the TI6 file, while more detailed results can be generated by running the model. More details on data output options are covered in **B6.7**.

6.3.4 Data Outline, Data Editor, Data Grids and Data Finder ^[TI6]

In TI6 there are several ways to view and edit model parameters, including use of program menus, toolbar icons and interaction with the Network Diagram. Three complementary options that can be accessed directly include the Data Outline, Data Editor and Data Grids, as described below.

The Data Outline, shown in **Figure 85**, is visible by default when launching the application and provides an overview of all categories of data contained in the model. The Data Outline is arranged in a logical hierarchy, which can be navigated and expanded / collapsed as desired to show any model parameters from global model options down to properties of individual model objects.

Also shown in **Figure 85** is the Data Editor, which can be opened by double-clicking an item within the Data Outline or by clicking on its toolbar icon. Once opened, the Data Editor shows all model parameters that can be viewed or edited for the currently selected item in the Data Outline or Network Diagram. Parameters shown within the Data Editor can be editable, read-only, if derived from other model parameters, or hidden, if currently unused or inapplicable. Additionally, model result values are highlighted in green to show they are up to date or red if they are out of

date, indicating whether a new optimisation or evaluation run needs to be performed. When clicking on individual parameters in the Data Editor a short description is provided at the bottom of the Data Editor window, with further details available via the Glossary reference in the Help menu.

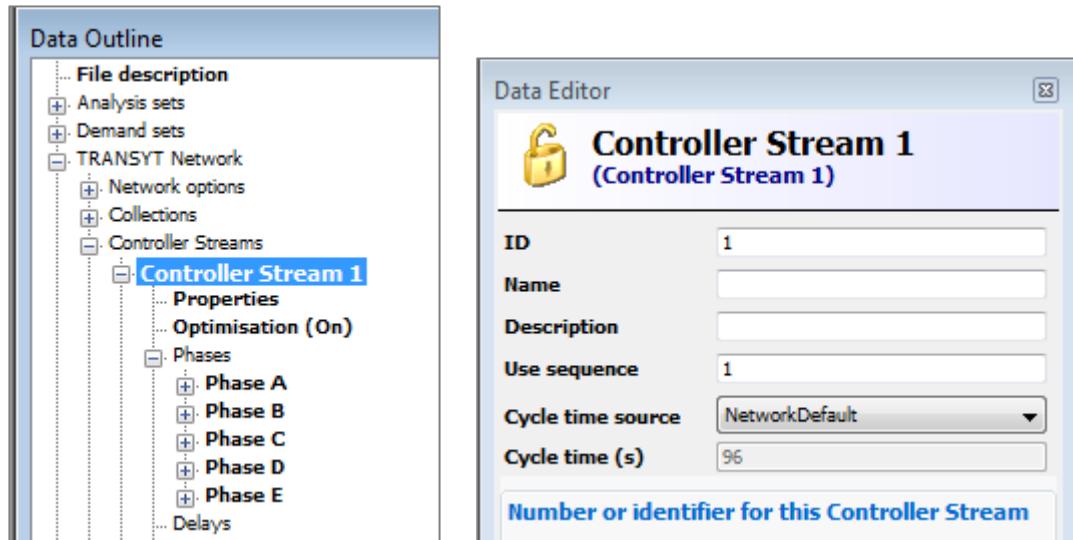

Figure 85: TRANSYT I6 – Data Outline and Data Editor windows

The content of the Data Editor window changes according to the item selected in the Data Outline or Network Diagram. The padlock symbol can temporarily override this behaviour, locking the current window content to the specific item clicked on, items of the same type, or frozen at that point in time without further updates being reflected. Additional Data Editor windows can be opened while the original remains locked.

The last and potentially most useful option to view or edit model parameters is the Data Grid (**Figure 86**), which is accessible by clicking on its toolbar icon or by right-clicking an item in the Data Outline. This shows data for all model objects of the same type within a single editable table, allowing a larger amount of model data to be viewed or changed at the same time.

The Data Grid behaves similarly to the Data Editor, with its content updating to reflect the item currently selected in the Data Outline or Network Diagram. The padlock symbol can similarly be used to lock the contents when required, allowing multiple Data Grids to be kept open at the same time. It is also possible to copy Data Grid content to and from external spreadsheet software.

Controller Stream	ID	Name	Description	Use sequence	Cycle time source	Cycle time (s)
1	1			1	NetworkDe...	96
2	2			1	NetworkDe...	96
3	3			1	NetworkDe...	96
4	4			1	NetworkDe...	96

Figure 86: TRANSYT I6 – Data Grid window

6.3.5 Analysis Sets and Demand Sets [T16]

In TI6, Analysis Sets enable different situations to be modelled within a single file, supporting use of alternative signal timing plans and variation of some model parameters. These can be useful for modelling different time periods, assessing alternative strategy options or for separating future proposals, although significant layout changes are not supported.

Where model parameters can be changed between different scenarios, a folder icon is displayed next to the relevant parameter in the Data Editor indicating if they are unique for that Analysis Set or shared with others.

Demand Sets are used to contain collections of traffic and pedestrian demand flows, with each allocated to a specific time of day and scenario description. Demand Sets can be used by themselves or combined with other Demand Sets and applied to any Analysis Sets.

When entering model data it is important to remember that the displayed values are relevant for the currently selected Analysis Set and Demand Set as shown in the drop-down menus at the top of the main program window and identified with asterisks in the Data Outline, as shown in [Figure 87](#).

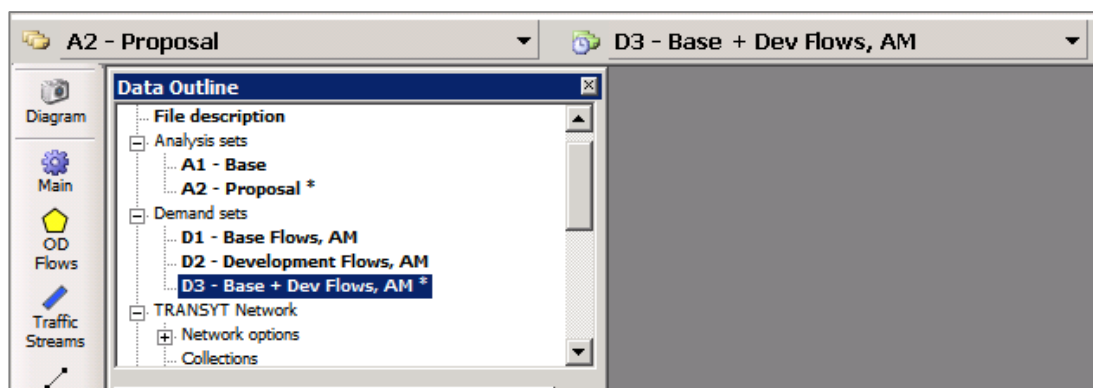

Figure 87: TRANSYT I6 – Selected Analysis Set (A2) and Demand Set (D3)

6.4 Base Model Calibration

This section provides guidance to support appropriate calibration of a TRANSYT Base model.

6.4.1 Calibrated Model

A calibrated TRANSYT Base model is defined as being a model which has correct network structure and geometric input data, and is submitted during Stage 2 of TMAP as identified in **B2.1.5**. It should contain representative signal timings for the period being modelled with no demand-dependent stage adjustments. The model should be accompanied with a technical note as detailed in section **B2.6**. This should state the purpose of the model, the modelled period, TRANSYT version number and study area.

6.4.2 Network Options

Before commencing model development, particular attention should be paid to the following TRANSYT network options which need to be appropriately specified.

If using TI6, it is recommended that the menu option 'Data / Use Advanced Mode' is selected in order to ensure that all network options and modelling parameters are accessible.

- **Monetary Value of Delay and Stops for Vehicles** – These terms represent the monetary values applied when calculating the cost of modelled delay and stops for vehicles, and their resulting contribution towards the network's overall Performance Index. The default values used in TRANSYT are:

Value of delay: 1420 pence per PCU-hour
Value of stops: 260 pence per 100 stops;
- **Number of Steps in Cycle / Resolution** – the number of steps should typically be equal to the cycle time. In TI6, the related Resolution parameter defines the number of steps per second during the cycle, therefore a Resolution of 1 gives the same number of steps as there are seconds in the cycle time;
- **Simulated Time (minutes)** – this represents the period in minutes over which the modelled flows are assumed to exist. This is commonly set to 60, as a peak hour is modelled using hourly flow

rates. However, if peak flow conditions exist for two hours on-street, even though only one hour is being modelled by TRANSYT, the simulated time value should be set to 120. This allows more accurate calculation of queues and vehicle delay. The default value in T12 is 120 whilst in TranEd and T16 it is 60;

- **Start / End Effective Green Displacements** – these account for the periods after the start and end of green when in reality vehicles are either accelerating or starting to brake. In TRANSYT's simplified traffic models vehicles are considered to be either stationary or moving at cruise speed during the displacement periods. The default parameter values are considered representative for typical conditions and should not be changed unless a specific survey is conducted for each stopline within a modelled area;
- **Flow Scaling Factor** – this should be unchanged from the default value unless modelling a change in flow volume (for example when looking at predicted increase / decrease in demand or using a 'flow-factoring' technique to model a peak for which specific flow data are not available). See section [B6.4.7](#) for further information on demand flow specification and allocation;
- **EQUISAT (T12) or Auto Redistribute (T16)** – for a Base model these should be disabled in order to maintain existing signal timing settings. EQUISAT or Auto Redistribute can be enabled as a starting point for the optimisation process when generating new timings;
- **Cruise Times / Speeds** – this should be set to use cruise times, as measured on-street and as detailed in section [B2.3.4.2](#);
- **Cruise Time / Speed Scaling Factor** – this should remain unchanged from default unless specifically required for a particular purpose (such as a proposed change in speed limit);
- **Level of Optimisation** – for a Base model, this should be set to 'No Optimisation' in T12, or untick 'Enable optimisation' in T16. This will provide performance results based on existing timings in the model. Offset optimisation and offset / green split optimisation should be used during the optimisation process for Proposed modelling. See section [B6.6.4.1](#) for further information on signal timing optimisation;
- **Enhanced Optimisation (T16)** – this option forces TRANSYT to cycle through the hill-climbing process multiple times in order to achieve optimal signal timings. As it takes longer than regular optimisation, its use is not typically recommended until fine tuning of final signal timings;

- **Enable OUT Profile Accuracy (T16)** – when this option is selected, local stop and delay values are not fully recalculated during the optimisation process if local flow profiles have not significantly changed. This speeds up optimisation and is therefore enabled by default, however unticking can increase optimisation performance;
- **Optimisation Type (T16)** – while T12 uses a standard Hill Climb process for all optimisation methods, T16 offers additional options including ‘Shotgun Hill Climb’ and ‘Simulated Annealing’. These may be able to find improvements in optimised signal timings but take longer to run, and are therefore not recommended until fine tuning final signal timings;
- **Exclude Pedestrians from PI Calculation (T16)** – typically this should always be enabled unless specifically trying to influence pedestrian splits or offsets during the optimisation process. It can alternatively be set at the Link / Traffic Stream level (see [B6.4.4.2](#)), which is the default method in T12;
- **Random Delay Mode (T16)** – for new models this parameter should be set to ‘Complex’, which is a more accurate method of estimating random and oversaturation delay that has been used as the default since TRANSYT I3. The alternative ‘Simplified’ method replicates the method used in TRANSYT I2, and should be used for backwards compatibility if importing older models to produce similar results;
- **Type of Vehicle-in-Service (T16)** – this parameter is used in the calculation of vehicle delay, and relates to how random or platooned vehicle discharge behaviour is assumed to be and therefore how likely vehicles are to slow down or stop (typically ‘Uniform’ for signalised approaches, as used in T12, and ‘Random’ for priority approaches, as used in PICADY / ARCADY). This should generally be set as ‘Automatic’, unless there is good reason to change it (seek advice if necessary); and
- **Type of Random Parameter (T16)** – this parameter is used in the calculation of queues and delay, and relates to how random or ordered queuing is assumed to be (typically ‘Uniform’ for signalised approaches, as used in T12, and ‘Random’ for priority approaches, as used in PICADY / ARCADY). This should generally be set as ‘Automatic’, unless there is good reason to change it (seek advice if necessary).

6.4.3 Traffic Behaviour Models

TRANSYT seeks to minimise vehicle stops and delays by adjusting signal timings to optimally coordinate platooned traffic arrivals and departures at stoplines. It therefore simulates the arrival, queuing and departure behaviour of vehicles at all stoplines throughout the modelled network using one or more pre-defined traffic models. TRANSYT's traditional macroscopic traffic models do not model individual vehicle behaviour but use average traffic demands during each modelled time step of a typical cycle.

TI2 uses a single network-wide model to simulate traffic behaviour, known as the Platoon Dispersion Model (PDM), which is also the default traffic model in TI6. Additionally, TI6 offers further traffic behaviour models, including the Link-by-Link PDM, Cell Transmission Model (CTM), Congested Platoon Dispersion Model (CPDM) and Simulation Model. TI6 similarly employs a network-wide default traffic model, however alternative traffic models can be specified for specific locations within the network. Each of the above traffic models are described in this section, along with their benefits and limitations.

6.4.3.1 Platoon Dispersion Model

In the Platoon Dispersion Model (PDM), vehicles are assumed to proceed undelayed until they arrive at a stopline. If the signal is red or there is a queue of one or more stationary vehicles, they join the stationary queue, otherwise they will proceed undelayed. The simplified queue model in the PDM treats vehicles as queuing vertically at the stopline, meaning it takes no account of the physical space that would be occupied by queuing traffic on street.

The PDM assumes that during a green period queued traffic discharges at a rate determined by the relevant saturation flow until the queue clears or the modelled green period ends. This arrival, queuing and departure behaviour is captured in the form of histograms called Cyclic Flow Profiles (CFPs), showing for each stopline the vehicle arrivals and departures (vertical axis) during each time increment within the modelled cycle time (horizontal axis), as shown in **Figure 88**. CFPs are covered in more detail in section **B6.7.2.2**.

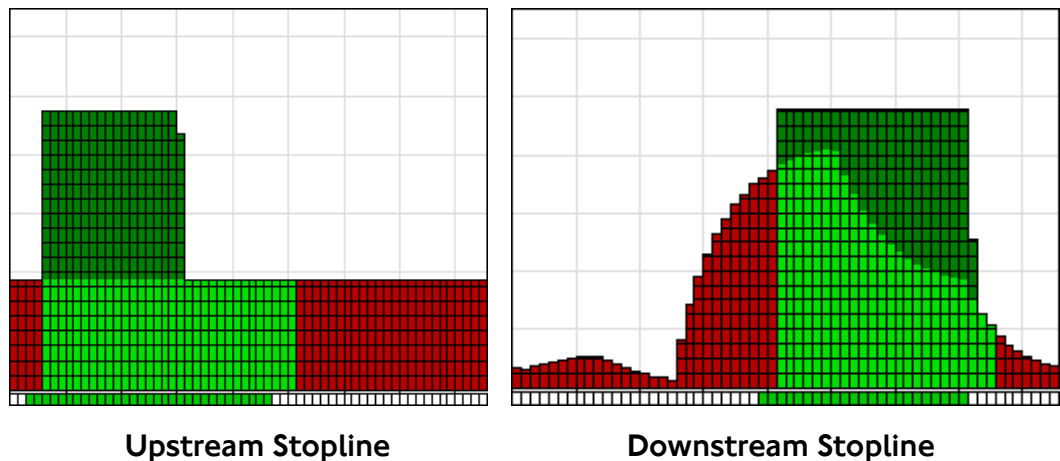

Figure 88: Cyclic Flow Profiles for neighbouring stoplines (viewed in TranEd)

TRANSYT aims to progress platoons of traffic through the network with an optimal set of signal timings. When traffic initially discharges from a stopline it is tightly grouped into a well-defined platoon, however as it progresses along a lane there is a tendency for the platoon to increasingly spread and become less well defined, which is referred to as 'Platoon Dispersion'. This is visible in **Figure 88**, with a rectangular OUT profile at the upstream stopline becoming a wave shape at the downstream IN profile. Vehicle platooning can be affected not just by distance travelled but by friction due to parked cars, road widths, bends or minor sinks / sources. However, the greater the distance between stoplines the larger the likely amount of dispersion, resulting in reduced potential benefit from traffic signal coordination.

Platoon Dispersion is accounted for in the PDM through exponential smoothing of the upstream OUT profile, taking account of the travel time to the next stopline and a 'Platoon Dispersion Coefficient' (K). The default value of K for normal traffic is 35, which should generally not be changed unless justified by sufficient supporting evidence. Similarly for buses and trams there are equivalent default dispersion coefficients that also take account of stationary dwell times between stoplines.

6.4.3.2 Link-by-Link Platoon Dispersion Model ^[T16]

The Link-by-Link PDM is a simpler implementation of the PDM within T16 that offers faster optimisation performance than the standard PDM, similar to the approach used in T12. The main constraint of the Link-by-Link PDM is that other traffic models are not supported within the same network, therefore only T12-style Quick Flares (section **B6.4.4.4**) can be

used that do not rely on use of the CPDM or CTM to model flare lane blocking effects.

6.4.3.3 Congested Platoon Dispersion Model (CPDM) ^[T16]

The CPDM is an extension to the standard PDM model that accounts for local blocking effects where traffic lanes feed flares or turning bays, however it is not suitable for modelling junction exit-blocking. While the CPDM accounts for reduced capacity of lanes due to adjacent queues, it may still be necessary to manually reallocate blocked traffic to other lanes where lane choice exists and uneven lane usage is observed or likely.

It is not possible to manually specify use of the CPDM in T16, although it will be used automatically when the model is specified as a 'Flare' and a short T16 lane is used (it is not used for T12-style 'Quick Flares').

6.4.3.4 Cell Transmission Model ^[T16]

The Cell Transmission Model (CTM) seeks to address the limitation of the PDM by accounting for the effects of exit-blocking. Like the PDM, it models the arrival and departure of vehicles at successive time steps during a typical cycle, again dealing with aggregate flows rather than individual vehicles. Unlike the PDM however, the CTM also models the movement of traffic within discrete increments in space along a length of road, allowing spatial occupancy to be represented. Each road section (represented by a Link or Traffic Stream) is therefore divided into homogeneous sub-sections called cells, as shown in **Figure 89**, which can each accommodate a finite amount of traffic at any time. The lengths of the cells are automatically calculated and are the same for all cells within a single Link / Traffic Stream.



Figure 89: Cells within a CTM section, coloured by traffic occupancy

At any specific point in time, the occupancy of each cell is known and will be somewhere between zero and a maximum value defined by the cell's available storage space. After each time step, traffic is able to flow between adjacent cells and any other upstream / downstream sections, providing downstream cells have sufficient available capacity to receive it. The automatically calculated cell lengths are sufficient to allow any traffic

movement to be accommodated within a single time step (traffic cannot move further than a single cell length within one time step).

Should there be insufficient downstream capacity, only a portion of the flow from upstream cells will be accepted (or none at all in the case of exit-blocking). Assuming downstream capacity is available, any traffic will be supplied from upstream cells at a rate limited by the relevant saturation flow. Note that for CTM road sections, two saturation flows are allowed, for:

- Stopleveline saturation flow (equivalent to the PDM saturation flow); and
- Cell saturation flow (equivalent to a saturation flow for the road section upstream of a stopline).

The specification of separate stopline and CTM cell saturation flows is intended to allow for variation in headways along a long road section to be accounted for, such as changes in the number of lanes, lane widths and parking, which may result in traffic congestion or gapping out either on the road approaching the stopline or at the stopline itself. When using Traffic Streams, Tl6 provides an option to auto-calculate cell saturation flows based on an assumed 1800PCU/hr per lane. Alternatively, for shorter road sections where headway variation is less likely, cell saturation flows can be manually set to match downstream stopline saturation flows as an initial estimate. Whichever approach is used, it should be revised where necessary to represent observed or expected behaviour and confirmed during model validation.

Care should be taken to ensure that no unintended discrepancies between stopline and upstream saturation flows result in unrealistic congestion or gapping out. This is particularly important where a low cell saturation flow may cause stopline starvation, preventing full stopline saturation flows from being achieved during a saturated green period.

Give-way behaviour is treated differently when using the CTM to represent capacity in a more realistic manner during congested conditions. This is covered in more detail in section **B6.4.6.6**.

While stops, queues and delays are defined as for the PDM, it is important to note that degree of saturation (DoS) is defined differently when using the CTM. Since 'wasted' green time due to blocking is inherently taken account of in the CTM, the DoS value is considered only to represent the proportion of available capacity that is used, meaning any wasted green time is deducted from the total green time. This may cause difficulty for

validation where CTM is used, particularly where sub-saturation flow is experienced, as traditional DoS survey techniques may not be suitable and direct application of site-measured UGT (section [B2.3.10.1](#)) is not possible.

The following limitations also apply when using the CTM:

- It is more computationally demanding than the PDM, which may affect model run times depending on network size and congestion levels;
- It is not possible to model traffic with different cruise times when using Link Shares (see [B6.4.4.3](#)), for example to account for different travel speeds and stopping time for buses / trams compared to general traffic;
- The minimum length for a CTM section is defined by the distance travelled in a single time step (which depends on the entered cruise speed and network time resolution). The CTM may therefore not be suitable for short sections; and
- The maximum length for a CTM section should be no more than 200m.

6.4.3.5 Simulation Model ^[T16]

The Simulation Model introduced in T16 is based on simplistic modelling of individual vehicle movements and allows more realistic representation of queuing behaviour, including blocking effects. It does this by simulating individual vehicle arrivals throughout the modelled time period and assigning them to individual Traffic Streams based on their desired destinations. Although detailed vehicle behaviour such as acceleration, deceleration, gap accepting and merging are not modelled, lane choice is considered whenever the available number of lanes changes or where Traffic Stream connectors lead to different destinations.

The arrival times and desired destinations of vehicles entering the network are influenced by randomness, therefore multiple simulation trials are required to give results that are representative of average behaviour. Stop Criteria specified in the Simulation Options are used to determine the number of simulation trials needed, which can be based on convergence of a suitable network parameter (default is Delay) or a simple maximum number of trials or simulation run time.

Since both randomness and the entire modelled time period are simulated, it is also possible to model dynamic effects such as demand dependency and the interaction between Controller Groups with different cycle times.

Once all simulation trials are complete, average model results for PI and Delay are reported in the Results Summary window. Average or percentile queues across all trials can also be visualised on the Network Diagram window throughout the modelled time period. Animations of individual vehicle movements and queuing / blocking can also be visualised on the Network Diagram using the animation controls; however, it should be noted that these represent a single trial only and do not therefore necessarily reflect typical behaviour across all trials. By default, the Random Seed in Simulation Options is set to -1, giving a different random seed every time simulation mode is run, so model results are likely to vary. If repeatable results are needed, the Random Seed should be set to a fixed positive value.

In summary, the Simulation Model in T16 provides the following benefits:

- More realistic queuing and associated blocking in congested conditions;
- Modelling of dynamic effects such as demand dependency and interaction between controller groups with different cycle times; and
- Visualisation of individual vehicles movements and average / percentile queues.

When deciding to use the Simulation Model in TI6 It is also important to be aware of the following limitations:

- Link-based network structures are not supported;
- Signal optimisation is not supported;
- No dedicated modelling of buses (treated the same as general traffic);
- Platoon dispersal is not modelled;
- DoS result data is not available;
- Models for complex networks can take longer to run; and
- Networks can sometimes become locked up.

6.4.3.6 Guidance on Traffic Model Choice

The PDM, as used in TI2 and the default model in TI6, is quick and effective when modelling uncongested conditions where queuing traffic does not cause blocking effects. It is therefore recommended that this is used as the default traffic model when building a model. The Link-by-Link PDM in TI6 (highlighted in **Figure 90**) can offer faster optimisation performance than the standard PDM, however is less suitable where flare blocking effects need to be modelled.

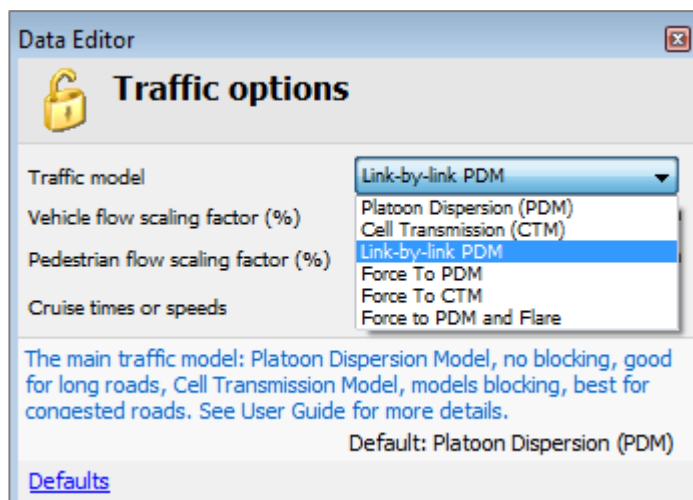

Figure 90: Traffic Model selection

Care needs to be taken where queuing traffic is observed or likely to occur however, such as at junction exits and turning bays or wherever reported traffic queues exceed available storage space (indicated by excess queues in model results, as discussed in **B6.7.1**). Blocking needs to be manually accounted for when using the PDM to ensure that capacity is correctly represented. This may include revision of signal timings to relocate queues (for example by using queue limit penalties) or through adjustment of modelled green times to account for any UGT (section **B2.3.10.1**) if queues

cannot be relocated. It may also be necessary to account for alternative lane choice when allocating traffic flows to represent resulting uneven lane use. It is also important to consider how these adjustments affect the optimisation process and any comparison between Base and Proposed models.

The traditional PDM flare model in TI2 (known as a 'Quick Flare' in TI6) provides some allowance for partial utilisation of flares caused by blocking through specification of an effective flare utilisation, which can be surveyed or predicted using tools such as TRL's QueProb feature within TRANSYT or JCT's LinSat.

In TI6, the CPDM provides a more accurate way of modelling blocking caused by flares and turning bays. This model cannot be manually selected but will be automatically used by TRANSYT for short flares. For longer flares, TRANSYT automatically uses the CTM for TI6 flares.

The CTM provides the ability to model blocking back, however it is more computationally demanding than the PDM and may therefore slow down model run times. With the CTM there are restrictions on minimum / maximum road section lengths and limited ability to use Link Shares (see [B6.4.4.3](#)) for bus modelling. It is important to be aware that DoS is measured differently under the CTM compared to the PDM, which may cause some difficulty for DoS surveys and model validation. Care should also be taken where there are discrepancies between cell and stopline saturation flows to ensure there are no unintended consequences (such as stopline starvation).

It is recommended that the CTM is not used for initial model runs, and only considered for specific congested Links if its use is considered advantageous, bearing in mind the restrictions mentioned. Alternatively, traditional techniques to account for blocking with the PDM should be used (for example application of UGT). It should never be necessary to use the CTM for entry or exit Links.

The Simulation Model in TI6 provides a further useful tool for analysis and visualisation of network behaviour in lightly congested conditions. It does not however support optimisation, Link-Based network structures or dedicated bus modelling. It should therefore be seen as an additional tool that is useful for analysing models with some congestion or to assess dynamic impacts such as demand dependency or the interaction between different cycle times. It is therefore not a replacement for TRANSYT's other traffic models and is also not a suitable replacement for more detailed microsimulation modelling where significant network congestion exists.

6.4.4 Network Structure

TRANSYT uses an abstract representation of the road network in order to display relationships between traffic and pedestrian movements, using a series of intersections and one-way road sections. Road sections take the form of either Links (TI2 and TI6) or Traffic Streams (TI6), which are explained further in this section. There are a number of different types of Links and Traffic Streams, and both Links and Traffic Streams can also be mixed within a TI6 network (section [B6.4.4.2](#)). Relationships between road sections are defined so that traffic is transferred from upstream sections to downstream sections according to the specified road layout.

As well as road sections, a number of other types of network element are defined to further describe traffic behaviour and control, which will be covered in the following sections. These include:

- Nodes;
- Controller streams;
- Priority Objects; and
- Pedestrian Crossings.

6.4.4.1 Nodes

Nodes are graphical objects that are associated with road intersections and allow graphical manipulation of intersecting road sections as a single entity. Nodes should not be used to represent physical phenomena within the carriageway such as road narrowing or widening.

In TI2, Nodes are essential items that are required to describe the controlled behaviour of conflicting traffic movements, whether due to traffic signals (section [B6.4.5](#)) or priority control (section [B6.4.6](#)). The amount of Node input data required depends on which form of control is to be modelled and is discussed further in the above sections. Non-signalised priority Nodes are treated as a separate Node type in TranEd.

In TI6, Nodes are optional items, as the relationship between conflicting traffic movements is defined at the Link or Traffic Stream level, with traffic signal behaviour modelled within Controller objects. Nodes in TI6 are mainly used for graphical identification and manipulation of individual junctions, and for providing routing refinement options during matrix-based flow allocation (section [B6.4.7](#)). TI6 Nodes also allow model results to be grouped by junction and their use is therefore recommended.

When using Nodes in TI2, a recommended Node numbering convention is provided in [Appendix III](#). This relates Node numbers to TfL junction references in a consistent manner and allows for the maximum supported

Node number limitation within TI2. For TI6 the required Node ID does not have the same limitation as in TI2, however for convenience the same numbering system can be used.

6.4.4.2 Links and Traffic Streams

Links and Traffic Streams both define one-way sections of road containing streams of similar traffic, and can represent one or more physical lanes. Traffic Streams can be used in TI6 and provide a simplified and more intuitive appearance for the user by using an equivalent underlying Link structure that is not visible, as shown in **Figure 91**. Some of the differences between Links and Traffic Streams are detailed in **Table 13**.

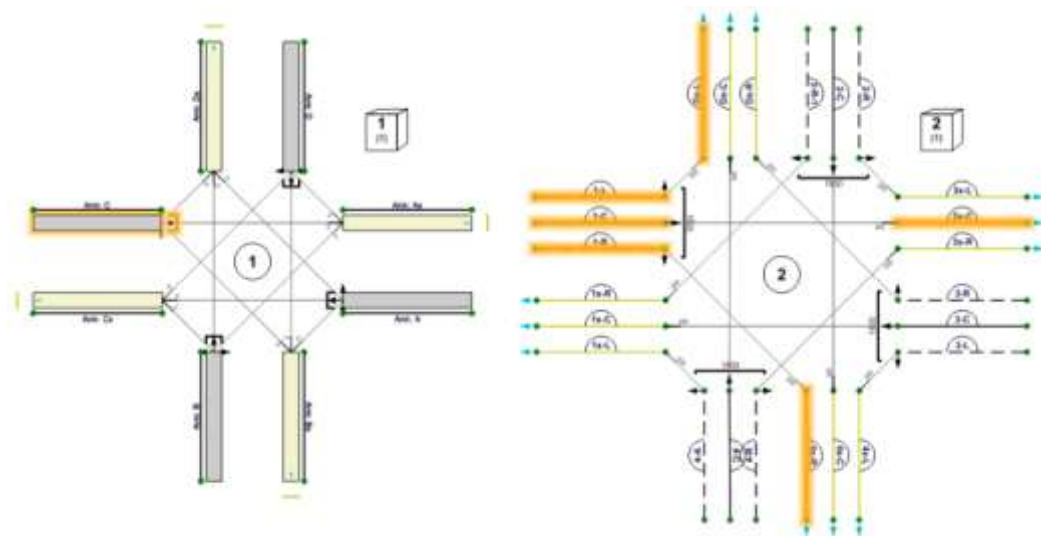

Figure 91: Traffic Stream structure (left) and equivalent Link structure (right)

Multiple lanes can be grouped together within a single Link or Traffic Stream only if they behave identically, that is:

- Flows must be distributed equally across all lanes;
- All lanes must queue evenly;
- All lanes must contain the same predominant traffic movements; and
- All lanes must share a common method of control.

If using Traffic Streams in TI6, individual physical lanes should be defined for each Traffic Stream. This provides graphical representation of the number of lanes and also allows separate specification or calculation of individual lane saturation flows. All Traffic Streams on a single approach road are collectively grouped into an Arm for graphical presentation and manipulation.

When using Links, there is no representation of individual lanes and a single saturation flow is entered to represent the capacity of all lanes within the Link. A recommended Link numbering convention for T12 is provided in [Appendix III](#) that makes efficient use of the supported Link number range. This can similarly be adopted in T16, however as T16 Link / Traffic Stream IDs can accommodate up to 10 alphanumeric characters, other conventions can be used.

Table 13: TRANSYT Link and Traffic Stream comparisons

Consideration	Link	Traffic Stream
Lanes	Not directly modelled, however a Link can be used to represent one lane	Individual lanes modelled
Capacity	Overall capacity directly entered. Can be calculated with RR67 estimation tool if additional lane and turn data provided.	Overall capacity can be directly entered or calculated from individual lane capacity contributions - these can similarly be directly entered or calculated with RR67 estimation tool.
Flow disaggregation	Link Shares allow flows of interest to be disaggregated (for example. buses, circulatory traffic, cyclists)	Flows automatically disaggregated based on route and traffic type (General, Bus, Tram)
Underlying Network Structure	Simpler – may give faster performance due to reduced number of path segments	More complex – higher number of path segments may slow down performance
Flow entry method	Flows can be directly entered or assigned using OD matrices	Flows must be assigned using OD matrices
Time-varying flow entry	DIRECT, GUASSIAN and FLAT flow profiles supported	DIRECT flow profiles required
Simulation Model Supported	No	Yes

Where multiple lanes exist that do not behave identically, they must be treated as separate Links or Traffic Streams, even if they share the same destination. The traffic flow on each Link or Traffic Stream should be proportioned according to observed lane usage during flow allocation.

6.4.4.3 Major and Minor Links (Link Shares)

If using Links in TI2 or TI6, there are two main types of Link – Major and Minor. A collection of associated Major and Minor Links (also known as a Link Share) represents all traffic at a stopline, with Minor (or ‘shared’) Links sharing the Major Link’s capacity and queue while allowing separation of Cyclic Flow Profiles for particular flows of interest. The Minor Link occupies the same physical road space as its associated Major Link but represents only a proportion of the Link Share’s flow and queue. Minor Links therefore facilitate analysis and optimisation of vehicle progression through the network by distinguishing between platoons from different sources, where in reality they form a single queue at the stopline. Up to seven separate traffic flows of interest can be disaggregated through use of Link Shares in TI6, while TI2 can support five.

Traffic Streams in TI6 do not support user-creation of minor shares, as all traffic using a Traffic Stream is separately distinguishable by traffic type (Normal, Buses, Trams) and also by route through the network if using Matrix-Based flow allocation.

Link Shares can be useful where user-defined disaggregation of flows is required, for example for separate analysis of individual bus routes. It is important to note that the choice of which Link is Major or Minor is arbitrary since they share all input data, so there is no effect on model output. For this reason, model output values from Major and Minor Links should not be summed as by nature there is only one value for DoS and queue length. The use of Link Shares can be helpful where complex travel patterns occur, such as at signalised roundabouts. Here it is desirable to optimise offsets between entry and circulating traffic so that excessive queuing does not occur on internal Links with limited storage capacity, which would interfere with efficient operation of the roundabout. It is also possible to model bus movements with Link Shares, unless there is a dedicated bus lane which should be modelled with a discrete Link.

6.4.4.4 Flared Approaches

Flared approaches may be physical, behavioural or environmental in nature, for example resulting from termination of a bus lane, funnelling on the exit of a junction, provision of a short turning lane or due to the presence of on-street parking. They are defined in TI2 by specifying a Link

as flared and entering the number of additional flare lanes available, together with their respective saturation flows and average utilisation in PCUs per cycle. This provides an increase in capacity above the Link's saturation flow for the duration the flares are utilised.

The same approach is supported in TI6, where flares of this type are referred to as 'Quick Flares'. Before Quick Flares can be used, they first have to be enabled by choosing the option 'Enable Quick Flares', which is found within the Data / Model and Result Options menu.

As described in [B2.3.8.6](#), flare utilisation should be determined from site-based measurement, for each period being modelled. Only where site measurement is not possible should alternative estimation techniques be used, such as use of TRANSYT's QueProb feature or JCT's LinSat software.

It is important to note that the simple flare modelling used in TI2 and TI6 Quick Flares do not inherently model any blocking effects caused by queuing in adjacent lanes, although site measurement or estimation of flare utilisation using QueProb or LinSat will account for flare starvation. Blocking of flows in adjacent non-flare lanes may need to be manually accounted for however, for example by reallocating flows to neighbouring lanes to reflect increased use of non-blocked lanes.

In TI6, improved flare blocking can be modelled by creating short lanes in the flared area with their traffic model specified as 'Flare', as shown in [Figure 92](#), although this is not possible when using the network-wide Link-by-Link PDM. Where the Flare traffic model is specified, short lanes use either the CPDM or CTM to model blocking effects between the flare lanes and upstream lanes. TI6 automatically determines which of the CPDM or CTM is most appropriate to use based on the flare length.

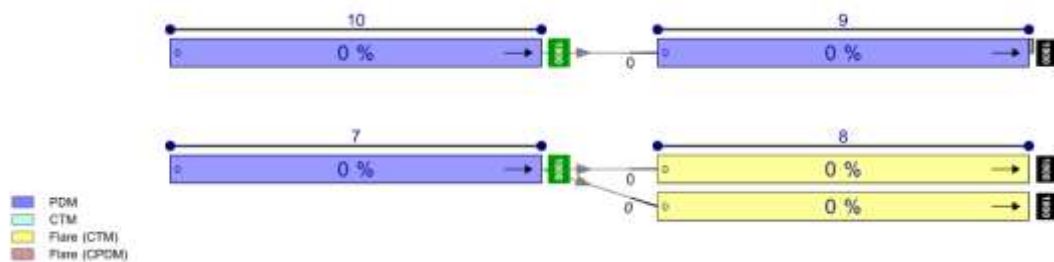

Figure 92: Alternative flare representations in TI6 using a Quick Flare (above) and with the Flare traffic model (below)

6.4.4.5 Classification of Links and Traffic Streams

Traffic Streams and Major / Minor Links are distinguished by how they operate on street, and are commonly classed as Signalised, Priority (non-signalised give-way), Bottleneck, Exit, or Pedestrian:

- **Signalised Links or Traffic Streams** (for example Link 6611 in [Figure 202](#)) represent traffic movements that are controlled by one or more signalised traffic phases at a junction;
- **Priority Links or Traffic Streams** represent traffic movements that are controlled by giving way to an opposing flow. They can either be pure give-way Links, modelled as green all the time and only controlled by the opposing flow, or signalised and therefore obeying signal control in addition to giving way to other traffic (as demonstrated by Link 6610 in [Figure 202](#), which represents a signalised opposed right-turn);
- **Bottleneck Links or Traffic Streams** attempt to represent flow-limiting behaviour which occurs between intersections rather than at stoplines or give-way lines, for example:
 - Where platoons progress through a narrowed carriageway;
 - To restrict entry to additional downstream lanes during carriageway fanning; or
 - Due to localised influences such as right-turn bays, loading bays, frequently used bus stops, start of bus lanes or uncontrolled pedestrian crossings.
- Bottlenecks are effectively treated as permanently green, where traffic throughput is solely determined by a specified saturation flow. Bottlenecks that cause queuing within a model should only be used where site observations suggest this is necessary to model mid-link phenomena and their impact on signal coordination;
- Exit Links or Traffic Streams can be used to represent traffic leaving the network (as shown by Link 6699 in [Figure 202](#)). In TI2, Bottleneck Links should be specified using an artificially high saturation flow, typically 8000PCU/hr, to avoid the creation of unintended and unrealistic queues. In TI6, Unrestricted Links or Traffic Streams should be used, requiring the 'Has Saturation Flow' Link / Traffic Stream property to be unticked).

- If queuing is observed to exist on-street from a downstream intersection outside the modelled network, then the modelling approach and use of TRANSYT should be re-assessed; and
- **Pedestrian Links** are normal signalised Links used within TI2 to represent movements controlled by signalised pedestrian phases (TranEd provides a 'Display as Pedestrian Link' option for visual identification). Each individual pedestrian phase should be modelled as a separate Link, especially where they run in parallel with traffic phases (as shown by Links 6650, 6651, 6652 and 6653 in [Figure 202](#)). Pedestrian Links should use proxy flows, Link lengths and saturation flows. All-round pedestrian stages may be modelled as a single Link even though there are several phases that run in that stage. However, if this approach is employed the largest clearance period must be used to determine the stage minimums. If using TI2, appropriate start and end lags should be calculated and checked against a skeleton LinSig model. In TI6, pedestrian Links are no longer used and Pedestrian Crossing objects should be used instead (section [B6.4.9](#)).

The Link input data required by TRANSYT varies according to the Link type and how it is to be modelled.

6.4.4.6 Properties of Links and Traffic Streams

All Traffic Streams or Major Links need to have the following properties specified:

- **Cruise time** – representing the average time for an un-delayed platoon to travel from the upstream stopline to the current Link's stopline.
- Cruise times represent a critical input parameter in TRANSYT, as they will be used to calculate optimum offsets during any optimisation. If cruise times are underestimated, the green signal will come in too early and the back end of a platoon may fail to clear the stopline. In contrast if cruise times are overestimated, the green signal will come in too late and result in the bulk of the platoon arriving on a red signal. Note that if prompted for cruise speeds rather than cruise times, program settings should be checked to ensure that cruise time entry has been enabled (section [B6.4.2](#)). In TI2, cruise speed will always need to be entered for bus Links, in kph (section [B6.4.8](#));
- **Link length** – preferably measured on-street with a measuring wheel, or from suitably scaled, high resolution aerial photography that has

been checked against on-street observations. TI6 provides the option to measure lengths automatically from a scaled background image;

- **Saturation flow** – as derived from on-street measured values (discussed in [B2.3.9](#)), or estimated where this is not possible. This parameter is only required for priority movements if they are also signal controlled. Saturation flows calculated from RR67 should be used with caution, and the suitability of estimated saturation flow values for the modelled area assessed as described in [B2.3.9.1](#).
- Saturation flows need to be directly entered for Links in TI2, while in TI6 they can be directly entered for Links and Traffic Streams or calculated from lane measurements using RR67. When using the built-in RR67 calculation functionality in TI6, it should be noted that unless using Traffic Streams with a scaled background diagram and the 'Use connector turning radius' option selected, turning proportions need to be manually specified and will not be automatically updated to reflect changes in modelled flows;
- **Modelled traffic flows** – these will either be directly specified or automatically determined from Matrix-Based demand flows, depending on the selected flow allocation method (section [B6.4.7](#));
- **Traffic type** ^[TI6] – for TI6, the traffic types (Normal, Bus or Tram) that are able to use the Link or Traffic Stream need to be specified; and
- **Traffic model** ^[TI6] – this will typically be set to the network-wide default traffic model, however alternative traffic models can be selected when necessary. This will most commonly be the case for flares or where the CTM is used to account for localised blocking effects.

The following advice relates to properties for specific types of Links or Traffic Streams:

6.4.4.6.1 Minor Links

Minor Links in a network need to be associated with a Major Link. Since a Minor Link occupies the same physical road space as the Major Link, the majority of key variables are inherited from the Major Link. Modellers should be aware that in a TI2 input file the saturation flow quoted for a Minor Link will instead be a reference to the associated Major Link.

6.4.4.6.2 Bottleneck Links / Traffic Streams

The correct capacity for a Bottleneck can be assessed by conducting a fifteen-minute traffic spot count for each modelled period where on-

street bottlenecks have been observed to result in mid-Link delay or queuing. If the model contains unrealistic queuing originating from a Bottleneck Link the saturation flow can be set to an artificially high value, but this must be explicitly stated and justified in the calibration report. In TI6, this can be achieved through use of an Unconstrained Link or Traffic Stream (by disabling the 'Has saturation flow' property).

Where Bottlenecks are used with the Platoon Dispersion Model, it is important to ensure that any resulting queue does not extend beyond the Bottleneck's storage capacity. Where this occurs, upstream signal timings will need to be adjusted, as described in [B6.4.5.6](#). As a rule of thumb, if a Bottleneck is less than 50m in length then any queue should not be allowed to extend beyond two-thirds of the Link length.

6.4.4.6.3 Entry and Exit Links / Traffic Streams

Since entries to (and exits from) the modelled network do not have upstream (or downstream) stoplines, their Link lengths and cruise times are arbitrary in nature. It is common therefore to use default values of 200m for entry / exit lengths and 18s for cruise times, based on an average speed of 40kph (~25mph), though the cruise time can be adjusted if observed vehicle speeds are significantly different.

In TI2, exits should have their stop and delay weightings set to -9999, as recommended for pedestrian Links, so that they do not affect the overall network PI. In TI6 the same effect can be achieved by ticking the option to 'exclude from results calculation'. The saturation flow for exits in TI2 should be set to 8000PCU/hr, as explained in [B6.4.4.5](#), while in TI6 the option 'Has saturation flow' should be disabled to define no saturation flow restriction.

6.4.5 Signal Control

This section details the implementation of signal timings within a TRANSYT model, using either Nodes in TI2 (section [B6.4.5.3](#)) or Controller objects in TI6 (section [B6.4.5.4](#)). Whichever method is used it is important to ensure that phase-based signal controller behaviour is accurately modelled, as described in [B6.4.5.2](#).

In TRANSYT the defined stage sequence for each controller is considered to recur throughout the modelled time period, therefore representing a 'typical' or average cycle. Further issues that require consideration discussed within this section include:

- Network cycle times (section [B6.4.5.1](#));
- Demand dependency (section [B6.4.5.5](#)); and

- Underutilised Green Time, or UGT (section [B6.4.5.6](#)).

6.4.5.1 Network Cycle Time

T12 should only be used to model signalised junctions which operate with a common network cycle time or fractions of a common cycle time, such as double-cycling, triple-cycling or quadruple-cycling. It is normally only practical to model one CLF or UTC group within a single T12 model. If it is determined that a proposal will influence traffic conditions in more than one region then it may be necessary to create two or more models to be run separately to represent the complete zone of influence and further microsimulation modelling may be necessary if they are expected to interact. The scope and area to be modelled should be discussed and agreed during TMAP Stage I as described in [B2.1.5](#).

T16 provides support for controllers to have different cycle times to the global network cycle time. Where this is the case, if neighbouring controllers share the same cycle time then platooned arrival profiles between them will be maintained. If this is not the case, then flows are maintained between the neighbouring sites, but uniform arrival profiles are assumed unless using Simulation Mode. Whether there is any perceived benefit in grouping differing cycle times within a single model is therefore a matter of judgement, and microsimulation modelling should be considered if significant interaction is expected. T16 also provides the option to limit cycle time choice to SCOOT-compatible values (section [B2.5.6.1.3](#)), which is recommended where timings will be implemented under SCOOT control.

6.4.5.2 Phase-Based Controller Behaviour

In order to accurately model phase-based signal timings as observed with on-street signal controllers, it is important to be aware of the following key differences and limitations with signal representation in TRANSYT:

T12 does not model controller phase green times, but instead uses Link green times relative to the start and end of stages. In addition, stages in T12 are defined as starting when the first phase in the previous stage loses green, unlike controller stages which start when all phases in the current stage become green (this results in T12 stages referring to the controller stage plus the preceding interstage).

Due to these differences, skeleton LinSig models should be used to provide assurance that Link signal timings are accurately represented in T12, particularly with respect to start lags, end lags and phase delays (described in more detail in section **B6.4.5.3**).

TranEd includes the 'Phase Intergreen Converter Tool' to help convert phase-based intergreen matrices into Link-Based timings when building a TRANSYT model. If this is used, phase lettering in TranEd should match those shown on TfL Controller Specifications and Timing Sheets.

T16 offers improved modelling of phase-based controller behaviour, however, it does not provide visibility of controller values for phase gaining delays, as shown in TfL Controller Specifications. Instead, when entering values, the user must determine whether they should be entered as absolute or relative, and whether further manufacturer-specific adjustments are appropriate. Phase gaining delays should therefore be carefully checked in T16 if using existing values from TfL Controller Specifications or Timing Sheets (section **B2.3.8.1**).

6.4.5.3 Node-Based Signal Timings ^[T12]

In T12, signal timing information is coded within Node data (Card Types I0, I1 and I2) and Link data (Card Type 3I) for all signalised Nodes and Links.

Node data that needs to be entered includes:

- Number of stages; and
- Whether the Node double-cycles.

For each defined stage within a Node, the following parameters are also specified:

- Time of change to the current stage – note that this refers to the start of a T12 stage as described in section **B6.4.5.2**, and not a controller stage;
- Interstage between the previous and current stages; and
- Minimum stage green time.

For signal-controlled Links, the following Link data values need to be entered:

- Signalised Node controlling the Link;
- Number of Link green periods per cycle;
- Stages the Link starts and ends in; and
- Start and end lag times, representing the period after the stage start and end times that the Link commences and terminates green. These should be set according to Link intergreen requirements and must also take account of any phase delays that are present (specified separately in TranEd).

6.4.5.3.1 Adjustment of Start and End Lags

Situations where it may be appropriate to further modify start and end lag values from those determined by intergreens and phase delays include:

- Demand dependency (section **B6.4.5.5**);
- Accounting for exit-blocking / Underutilised Green Time (section **B6.4.5.6**);
- Modelling bus set-backs (section **B6.4.8**);
- ‘Bonus’ storage effects (such as storage in front of a stopline for opposed right-turners which clear in the intergreen, and indicative arrows);
- Aggressive driver behaviour at particular junctions, resulting in usage of the starting amber and red periods; and
- Vehicle usage of flashing amber periods at Pelican crossings.

This list is not exhaustive and other situations may be encountered where other start and end lag adjustment is appropriate. It is up to the modeller to justify any decisions taken, and to fully report on all adjustments. This is particularly important where multiple adjustments are made on the same Link, as it can become impossible to audit signal timings if modifications are not well documented.

Where TranEd is used, start and end lag adjustments should be made using 'bonus green', which allows modelling adjustments to be separated from timings dictated by interstage design, such as Link delays and intergreens. Stage timings, intergreens, Link delays and bonus green adjustments can be visually distinguished using TranEd's Stage Timings View.

6.4.5.4 Controller-Based Signal Timings ^[T16]

In T16, signal timing data is no longer stored within Nodes but within separate Controller Stream objects, which can be applied to either Link or Lane-Based networks.

Controller Streams can be added using the dedicated Controller Stream button within the Network Diagram window, or by right-clicking on the Controller Streams entry within the Data Editor. Once created, the following data needs to be specified:

- **Controller Stream ID** – a unique identifier for the Controller Stream;
- **Cycle Time** – 'Network Default' uses the defined network-wide cycle time, however other cycle times can be manually specified or derived from another Controller Stream ID;

Note that if multiple-cycling is required, this should be specified within the Stage Sequence data rather than entering a lower Controller Stream cycle time here, which would result in uniform arrival profiles and loss of platoon coordination.

- **Phases** – including phase letter, phase, type minimum / maximum green values and, if required, any modelled green start / end adjustments;
- **Stages** – Stage ID reference (the stage number), phases within the stage and minimum stage time. Defined stages are stored within a Stage Library and allocated a Library Stage Number, which is arbitrary and should not be confused with the Stage ID;

- **Stage Sequences** – taking note of any prohibited stage moves or alternative stage moves where necessary; and
- **Phase Delays** – note that care needs to be taken when entering phase gaining delay values from Controller Specifications or Timing Sheets. Phase gaining delay values must be correctly interpreted as either absolute or relative, and take account of manufacturer-specific differences (Siemens gaining delay values do not include the Red / Amber period for traffic phases).

Once the Controller Stream has been defined, the Intergreen matrix can be entered using the Matrices screen, together with details of any banned stage movements. Specific signalised Links or Traffic Streams need to be associated with the relevant Controller Stream and controlling phase(s) by specifying the Controller's ID within the Link or Traffic Stream's Signals properties.

Stage timings can be interactively edited using the Timings Diagram window or via Timing Wheels within the Network Diagram window.

6.4.5.5 Demand-Dependent Stages

As TRANSYT's traditional macroscopic models only model a 'typical' cycle with a fixed stage sequence, all stages are assumed fully demanded. They do not therefore inherently capture the effects of demand dependency, where stage demands may vary from cycle to cycle (although this can be modelled using Tl6's Simulation Model, which is covered in [B6.4.3.5](#)).

It is, however, important to capture the effects of demand dependency during model assessments, either to ensure the network remains within capacity or to test traffic management strategies during oversaturation. This can be achieved through manipulation of the modelled signal timings to reduce or increase green times, accounting for alternative stage sequences that may appear.

Demand-dependent stage frequency can significantly affect the amount of green time received and can vary by time of day. The modeller must ensure that all modelled adjustments result in appropriate green times, and that their calculation and implementation are adequately recorded. For example, if a junction has been modelled with a pedestrian stage being activated every cycle, when in reality it is only called 50% of the time, then the model is likely to underestimate the capacity available to one or more movements.

There are two common methods used for manipulation of modelled green times to account for demand dependency:

- In TI2, start or end lags can be adjusted so that modelled green times are extended or reduced for specific Links to provide green time to other stages when a demand-dependent stage does not appear. This can similarly be achieved in TranEd through the use of Node Bonus Greens, which offer the advantage of preserving controller interstage design as existing intergreens and Link delays remain unchanged, which is helpful both for auditing and subsequent use of the model. In addition, Links sharing the same controlling phase can be independently adjusted. There is a limitation on how much green time adjustment is possible using this method however as Links cannot be active in stages they are not assigned to in the junction's method of control. This may necessitate additional use of a dummy stage.

In TI6 the start and end of green times for Links and Traffic Streams are determined from their associated phases. It is possible to use a similar technique using Relative Start or End Displacements for the phases in question, however it is important to be aware that this affects all Links / Traffic Streams sharing the same controlling phase. If necessary, an equivalent dummy phase can be created to control a specific Link or Traffic Stream if it shares the same controlling phase as others and needs to be independently controlled, however this should be recorded and explained; and

- Another method involves the creation of a dummy stage to use in place of the demand-dependent stage in the stage sequence, with its stage length reduced proportionally to represent the frequency of demand observed. The timing of the dummy stage appearance should then be adjusted to take account of how the time is shared between the preceding and following stages in the event of non-appearance of the demand-dependent stage (section **B2.3.8.5**). The dummy stage method is discouraged unless necessary as Proposed models are required to have all stages modelled with controller minimum stage lengths in order to optimise junction performance and distribute spare green time.

6.4.5.6 Underutilised Green Time (UGT)

The standard Platoon Dispersion Model (PDM) within TRANSYT (described in section [B6.4.3.1](#)) stores queues vertically and thus has difficulty considering the impact of queuing from the stopline. TRANSYT models based on the PDM cannot therefore automatically take account of the effect on adjacent or upstream Links if a queue extends beyond a Link's storage capacity.

Wasted green due to exit-blocking can be quantified through direct measurement of Underutilised Green Time (UGT) during an on-site DoS survey (described in section [B2.3.10](#)). UGT accounts for both wasted green due to exit-blocking, during which traffic is stationary, and sub-saturation flow, during which traffic is slow moving due to downstream queuing and congestion.

To account for blocking back, the effective lost time has to be manually applied to relevant lane movements. This can be achieved by modifying Link start and end lags in TI2 (or Bonus Greens in TranEd), as explained in section [B6.4.5.3.1](#), or by applying Relative Start or End Displacements to relevant phases in TI6, as discussed in [B6.4.5.5](#). Where these methods are not possible due to TRANSYT program constraints, dummy phases and stages can also be used. It is important that any manipulation of signal timings to account for UGT should be stated within the model validation report and supported by accompanying survey data.

In TI6, the Congested Platoon Dispersion Model (CPDM) is able to take account of limited blocking effects caused by queuing in adjacent lanes and the Cell Transmission Model (CTM) can take full account of blocking caused by any upstream queuing. It is therefore not appropriate to model wasted green caused by stationary queuing where these models are used, however these models do not account for additional lost time caused by slow-moving queues in sub-saturation flow conditions. The wasted green reported by TI6 may therefore be less than that measured during a site survey, and if this is the case some further adjustment of Relative Start or End Displacements may be necessary. It is important to note that the DoS reported by TI6 when using the CTM is based on the proportion of available green time used (not including wasted green periods) rather than the total green time, therefore this needs to be accounted for when validating against site-collected DoS data.

6.4.6 Priority Control

Priority movements are traditionally modelled in TRANSYT assuming linear relationships between give-way capacity and any opposing flows. Empirically-derived parameters are used to describe these relationships, which are dependent on the nature of the priority movement, junction geometry and other site-specific characteristics. The behaviour of a priority movement can also depend on whether it is signal-controlled or in close proximity to opposing signal-controlled movements. This section provides further detail on appropriate calibration of priority control in TRANSYT.

6.4.6.1 Opposed Movements at Signals

Where right-turning movements are opposed at signalised junctions, the following first need to be defined for each priority movement:

- The Links or Traffic Streams containing opposing traffic movements; and
- For TI6, the percentage of vehicles from the opposing Link that each opposed movement gives way to.

TI2 allows up to two opposing Links to be specified, while TI6 supports up to sixteen opposing Links or Traffic Streams. For Links a proportion of the Link's flow can be specified to give way only to the first opposing Link, while for Traffic Streams give-way behaviour can be applied to all movements or separately for individual opposed movements.

It is important to be aware that when specifying multiple opposing Links they cannot be separate lanes of the same opposing movement, for instance where an opposed right-turn gives way to multiple lanes of traffic in the other direction. In this situation multiple opposing Links should be combined into a dummy Link so that a single opposing Link can be specified in the opposed Link give-way parameters. If it is desirable to keep the flows distinct in the combined dummy Link, a Link Share can be used to separate the flows.

Once the opposing flows have been defined, there are two possible approaches for modelling the actual give-way behaviour – a simple linear relationship based on average flows within the modelled period, or a more complex relationship based on geometry, storage and conflict analysis that is available in TI6 only, which is separately calculated for each simulation step.

6.4.6.1.1 Traditional Give-Way Model

The traditional approach used in TI2, and also available in TI6, defines a linear relationship between the average opposing and opposed flows within a modelled period. This requires consideration of the following:

- The number of vehicles able to turn during gaps in the opposing flow(s);
- The number of vehicles that turn during the interstage period;
- The controlling movements opposing the opposed flow; and
- Whether right-turning vehicles share lanes with other movements that are blocked.

The numbers of right-turners that are able to make use of gaps in the opposing flow(s) are determined by specific give-way parameters, describing the linear relationship between opposed and opposing flows:

- **Maximum flow while giving way** – known as the ‘intercept’, identifying the maximum flow giving way while no opposing flows are present; and
- **Give-way coefficient** – known as the ‘slope’, describing how the opposed flow varies with increasing opposing flow.

Typical values are often used as a starting point for these parameters, representing commonly encountered give-way scenarios. Reasonable values suggested by TRL for an opposed right-turn at a signalised junction giving way to straight-ahead traffic are⁸⁸:

- Maximum flow of 1000PCU/hr; and
- Give-way coefficient of 0.5 (entered as 50 [$\times 10^{-2}$] in TI2 / TranEd).

These values assume an opposing DoS above 50% where the opposed movement is non-critical to junction performance, although they will be conservative if the opposing flow is less saturated. The values can be further modified if supported by more accurate data, such as site-based measurements from the location in question. This is especially important if the opposed movement is considered critical to junction performance.

The number of opposed turners that turn during the intergreen period can be accounted for by adding a ‘bonus effect’ to the signal timings. This is achieved in TI2 by increasing the end lag for the opposed Link, or in the case of TranEd by the addition of bonus green, as discussed in section **B6.4.5.3.1**. The additional time added should be long enough to clear the number of vehicles that are able to store in front of the stopline. It is common to add two seconds per vehicle for opposed movements that do

88 Binning J C, TRANSYT I6 User Guide, Application Guide 73 (Issue B), TRL, 2019, pp 397

not have an unopposed period, and one second per vehicle if an unopposed period follows (for example an early cut off for an indicative arrow stage). This is not necessary in TI6 if storage in front of the stopline is explicitly modelled as a short Link or Traffic Stream with the traffic model set to 'Flare', as the bonus effect of traffic storage in front of the stopline is accounted for. In this case, the upstream Link feeding the storage area should not be defined as giving way.

Where an opposed right-turn movement shares a single lane with an unopposed ahead movement, this can lead to interference and blocking. This is modelled by specifying a proportion of the opposed flow as giving way to nothing (the ahead movement), while the remainder (the opposed right-turn) gives way to the opposing Link or Traffic Stream. This combines the effect of right-turners giving way and the ahead movement discharging at the Link's saturation flow. It does not account for any vehicles entering the junction without blocking the ahead movement and may therefore slightly underestimate capacity.

In TI2, if an opposed right-turn movement shares a lane with unopposed ahead traffic, but a separate ahead lane also exists, then an allowance should be made for the likelihood of right-turners blocking the shared lane. This reduction in ahead capacity can be achieved through modification of the saturation flow if the ahead lane is modelled as a single Link, though this is not recommended. The preferred approach is to split the ahead movement into separate Links and allocate flows between them according to observed lane usage for each modelled period.

Again for TI2, if a right-turn bay exists that allows some storage of right-turning traffic separate from any ahead lanes, the modelling approach taken depends on whether right-turn traffic will queue back and block the adjacent ahead lane or not. If blocking back does not occur, the right-turn and ahead lanes should be modelled as separate Links, however the ahead lane may experience reduced capacity due to the effect of slowing right-turning traffic. This should be accounted for with UGT, or if necessary, by appropriate reduction of the ahead lane's saturation flow. If blocking back occurs, the right-turn bay and adjacent ahead lane should be modelled as a single Link using the give-way parameters detailed previously, with a proportion of the flow opposed by nothing and the remainder opposed by a specific Link.

In TI6, the right-turn bay and adjacent ahead lane should be modelled as short Links or Traffic Streams, with the traffic model set to 'Flare', as described in section **B6.4.4.4**. This will account for the associated capacity loss due to lane blocking effects.

6.4.6.1.2 Step-wise Opposed Turn Give-Way Model

TI6 includes a new give-way model, called the Step-wise Opposed Turn (SwOT) model, that can be used for opposed right-turn movements at signalised junctions. This model is based on research contained within TRL's Research Report 67 (RR67, section **B2.3.9.1**), and calculates give-way capacity at each modelled time step based on actual opposing flows rather than for the entire modelled period based on average opposing flows as in the traditional approach. TRL consider this method to be superior to the traditional approach described above that is used in earlier TRANSYT versions.

The SwOT model is enabled for specific give-way Links or Traffic Streams by clicking the 'Use Step-wise Opposed Turn Model' option within the give-way model options. It then requires the following parameters to be entered:

- **Number of storage spaces** – this is the storage space in front of the stopline in which turning traffic can store without blocking straight-ahead traffic. This parameter should be set to zero if downstream turning storage has been explicitly modelled with its own Link or Traffic Stream;
- Note that this parameter is not used to calculate the bonus effect due to turners during the intergreen period, which should continue to be modelled as for the traditional give-way method if downstream turning storage has not been modelled;
- **Radius of turn** – the radius of curvature for opposed turning vehicle paths. There is an option to automatically calculate this from the connector radius if a scaled background diagram is used, however this should not be relied on and any calculated value should be checked for accuracy;
- **Conflict Shift** – for each opposed movement, this is the time from the opposing traffic passing the stopline to clearing the give-way conflict. It is dependent on junction geometry and is typically expected to be a small positive number of seconds; and
- **Conflict Duration** – for each opposed movement, this is the delay after the conflict has cleared before opposed traffic is considered to discharge (similar to a start displacement following a green signal). It is normally expected to be two seconds, with lower values being more aggressive and likely to give optimistic results.

6.4.6.2 Mutually Opposed Traffic Movements

TI2 cannot model mutually opposed Links, the means a Link that is opposed cannot itself be specified as opposing another Link, although this is possible in TI6. As a workaround for TI2 when mutually opposed movements occur, the saturation flow for one Link (usually the one with the lower opposed flow) can be manually adjusted to account for its actual capacity and the other specified as the opposed Link.

In TI6, the following give-way coefficients are recommended by TRL as a starting point when modelling mutually opposed Links or Traffic Streams⁸⁹:

- Maximum flow while giving way = 715PCU/hr; and
- Slope coefficient = 0.22

6.4.6.3 Opposed Movements near Signals – Indirect Traffic Control [TI6]

TI6 allows discharge from a unsignalised priority movement to be influenced in the vicinity of opposing upstream signals, due to driver knowledge of the upstream signal state. This is referred to as Indirect Traffic Control and can be used when modelling situations such as:

- Nearside slip lanes giving way to traffic exiting a signalised junction; and
- Priority movement downstream of a signalised pedestrian crossing.

To set up Indirect Traffic Control, a give-way Link or Traffic Stream should have a saturation flow set in addition to give-way parameters. If the opposing Link or Traffic Stream is signalised no further action is necessary, however if the opposing Link or Traffic Stream is unsignalised then the option 'Upstream signals visible' option needs to be ticked. This allows discharge to be limited by the give-way relationship when opposing traffic is expected but by the saturation flow when it is known to be absent. This allows for higher discharge when drivers know that they do not need to give way.

6.4.6.4 Priority Junctions and Roundabouts

It is possible to model priority junctions and roundabouts within a TI2 model but this is only appropriate where these form part of a larger network comprised of chiefly signalised junctions. TI6 however can model

priority junctions and roundabouts in both signalised and fully unsignalised environments.

Priority give-way junctions in TI2 are modelled as 'virtual' signal-controlled junctions (TranEd provides a dedicated 'Non-Signalised' Node type), with stoplines representing give-ways. A similar approach can also be used in TI6, although Priority Objects can also be used (discussed further in section **B6.4.6.5**). For Links or Traffic Streams that give way to opposing movements, up to two opposing Links can be specified in TI2, and up to 16 for Links or Traffic Streams in TI6.

For each opposed movement it is necessary to specify:

- Which Links or Traffic Streams oppose the priority movement;
- The maximum unopposed flow at the give-way line (the intercept);
- Give-way slope coefficients – for each opposing movement, describing the linear relationship between the opposed and opposing flows; and
- Where more than one conflicting movement is specified, a percentage needs to be entered to describe the proportion of vehicles that give way to each conflicting movement. For Links, this is entered as the proportion that gives way to the first conflicting Link only, with the remainder assumed to give way to all conflicting Links.

The give-way intercept and slope coefficients determine gap-seeking behaviour, and for priority-controlled junctions are recognised to depend on the following:

- Width of the give-way approach;
- Width of the main road;
- Visibility to the right;
- Visibility to the left; and
- Volume of the controlling flow(s).

These are described in further detail in the appendix of TRL report LR888 and in subsequent TRANSYT user guides. Similarly, the intercept and slope coefficients for give-ways at standard roundabouts are recognised to depend on:

- Widths of the approach and roundabout entry;
- The extent of flaring at the give-way line;
- Inscribed diameter of the roundabout;
- The conflict angle between entry and circulating traffic; and
- Entry radius for entering traffic.

Typical values are often used as an initial estimate for give-way coefficients in chiefly signalised networks, representing commonly encountered give-way scenarios. Where priority junction performance is considered critical to a model however, it is appropriate to use more accurately estimated or measured give-way parameters in TRANSYT. This can be achieved by using:

- PICADY for estimating give-way parameters at priority junctions;
- ARCADY for estimating give-way parameters at priority roundabouts; or
- Measured on-site data, plotting various opposing and opposed flow rates from which the intercept and slope can be measured.

Reasonable values suggested by TRL for an opposed left-turn from a T-junction side road, queuing in a single lane and giving way to vehicles approaching from the right, are⁹⁰:

- Maximum flow of 715PCU/hr; and
- Give-way coefficient of 0.22 (entered as 22 [$\times 10^{-2}$] in TI2 / TranEd).

Similarly, reasonable values for an opposed right-turn from a T-junction side road, queuing in a single lane and giving way to vehicles from both directions, are⁹¹:

- Maximum flow of 600PCU/hr;
- First give-way coefficient (for traffic approaching from right) of 0.22 (entered as 22 [$\times 10^{-2}$] in TI2 / TranEd); and
- Second give-way coefficient (for traffic approaching from left) of 0.19 (entered as 19 [$\times 10^{-2}$] in TI2 / TranEd).

Where a single queue of side road traffic at a T-junction includes both left and right-turning movements, the above values can be used as a starting point in a Link-Based network but with the parameter '% giving way to first Link only' used to proportionally account for some traffic giving way to traffic approaching from the right only. Alternatively, for Links in TI6 a Link Share can be used with separate give-way parameters for each Link to allow for the different movements as described in the TI6 manual. When using Traffic Streams in TI6 this is unnecessary as give-way parameters can inherently be specified separately for individual movements.

TI6 includes further support for the modelling of priority junctions and roundabouts, with the inclusion of PICADY and ARCADY modules, as discussed in **B6.4.6.5**.

90 Binning J C, TRANSYT I6 User Guide, Application Guide 73 (Issue B), TRL, 2019, pp 530

91 Binning J C, TRANSYT I6 User Guide, Application Guide 73 (Issue B), TRL, 2019, pp 531

6.4.6.5 Priority Objects [TI6]

Priority Objects in TI6 allow priority intersections to be easily represented within a TRANSYT network, and include support for T-junctions (as shown in **Figure 93**), crossroads, staggered junctions and roundabouts. These utilise PICADY and ARCADY modules to accurately estimate appropriate give-way parameters based on site-specific geometry, with all relevant conflicts accounted for. As PICADY and ARCADY functionality is used, licences for these TRL products are required in addition to a TRANSYT licence.

In order to utilise a Priority Object within a TRANSYT network, it is possible to import a pre-built priority junction or roundabout using a relevant Library File, which includes pre-configured Links / Traffic Streams and associated conflicts. Alternatively, an 'empty' Priority Object can be added to an existing model which then needs to have specific Links or Traffic Streams associated with entry and exit arms based on PICADY / ARCADY arm-labelling conventions.

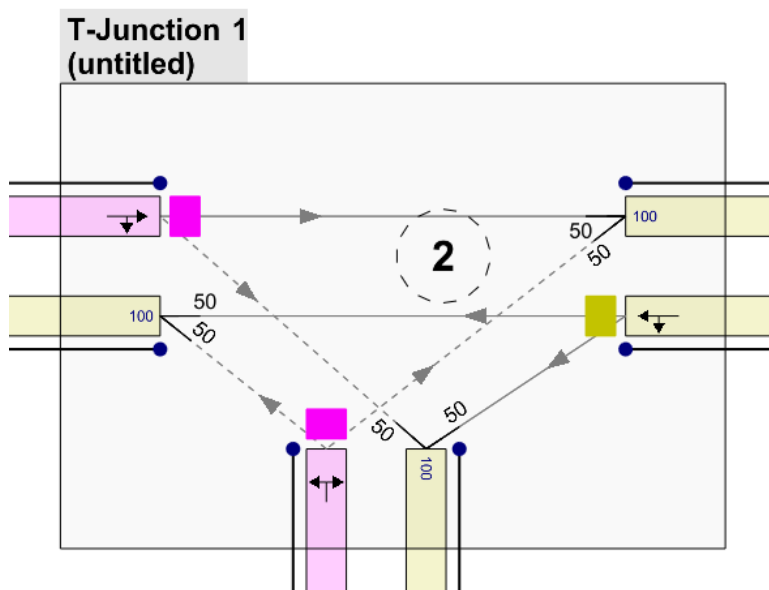

Figure 93: T-Junction Priority Object as seen in the TI6 Network Diagram

It should be noted that Priority Objects do not include the full functionality of PICADY and ARCADY, such as allowance for pedestrian crossings on entry and exit arms, estimation of queue variability or accident prediction. Where this level of modelling is required use of PICADY or ARCADY may still be necessary, either in addition to or instead of TRANSYT – the relative benefits of each should be assessed against modelling requirements for specific projects.

As the capacity of any priority approach is dependent on the time-varying nature of opposing traffic arrivals, consideration should be given to the use of time-varying demand flows in TRANSYT (section [B6.4.7.4](#)) where priority junction performance is critical or of particular significance.

6.4.6.6 Congested Priority Behaviour in the Cell Transmission Model ^[TI6]

The CTM in TI6 allows congested priority behaviour to be modelled, accounting for more realistic give-way capacity during these conditions. This is based on an extension to TRANSYT's traditional linear give-way model, assuming that from the onset of congestion give-way capacity increases to a user-defined 'Maximum Congested Give-Way Capacity' before decreasing linearly as opposing flows fall due to the effects of congestion. These uncongested and congested linear relationships are illustrated in [Figure 94](#).

If no user-defined value is provided then the Maximum Congested Give-Way capacity will be assumed the same as the minimum uncongested capacity at the onset of congestion.

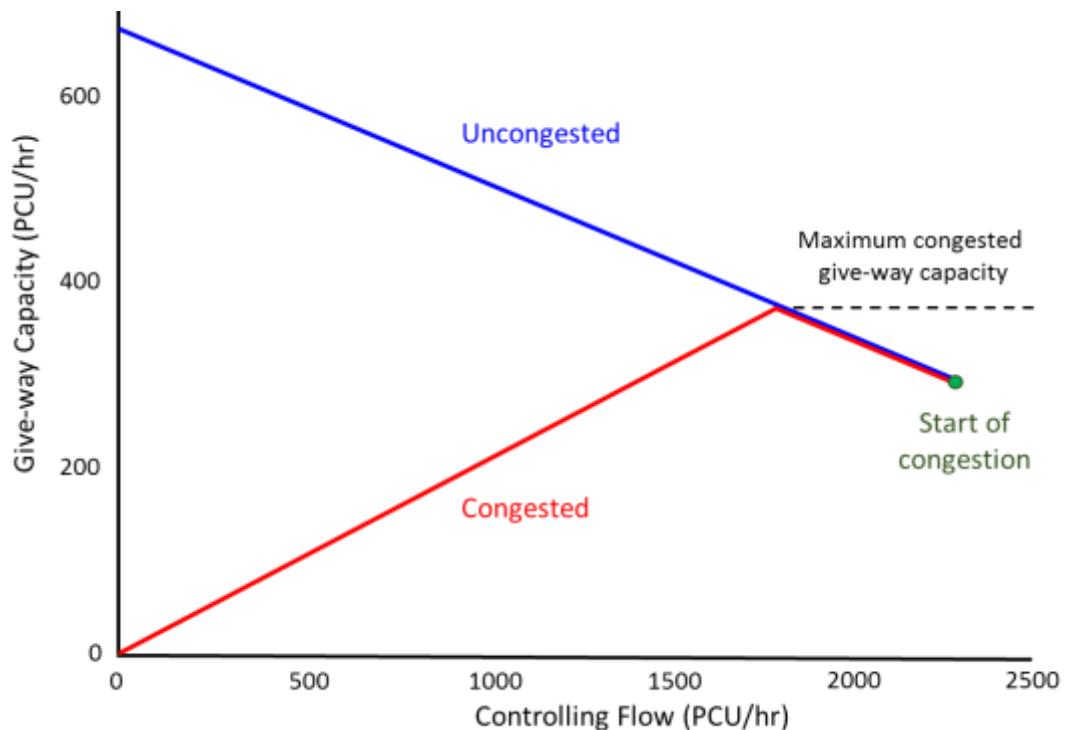

Figure 94: Congested give-way behaviour in the Cell Transmission Model, adapted from the TRANSYT I6 user guide⁹²

6.4.7 Traffic Flows and Flow Allocation

Traffic flows can be allocated to individual Links or Traffic Streams using different methods, depending on the network structure and TRANSYT version being used.

For Link-Based networks, flows can be entered directly for each Link (the only method supported in T12), while in T16 flows can also be allocated from user-entered flow matrices (this is the only method supported for Traffic Streams).

These flow entry methods are discussed in more detail within this section.

6.4.7.1 Direct Flow Entry (Link-Based Networks)

Flows can be directly entered for individual Links in a Link-Based network, and this is the only option supported in T12. For each Link or Link Share, the following information needs to be supplied:

- Total flow across the current Link's stopline;
- Contributing source flows from upstream Links; and
- Cruise times from upstream Link stoplines to the current Link's stopline (or bus speed for bus Links).

In T12 flows are entered in PCU/hr, while in T16 the flow unit is determined from the 'Data / Unit...' menu settings (either vehicles or PCUs per hour can be chosen).

In addition to contributions from upstream Links, a uniform flow source can also be specified to represent a source or sink along the Link that has not been explicitly modelled as an entry or exit from the network. This is an additional flow that is either added or removed from the Link with a uniform arrival profile.

It is not a requirement in TRANSYT for the total flow on a Link (the output flow) to exactly match the sum of the contributing flows (the input flows). If the total flow is different from the flow inputs on a Link, TRANSYT assumes that the total flow is accurate and will therefore proportionally increase or decrease the upstream flow values in order to achieve the total Link flow entered. This methodology works reasonably where Link input flows are roughly equal to the output flows. However, where there is a significant Link flow discrepancy, it can lead to inaccurate modelling and result in downstream flows that are in excess of upstream stopline saturation flows. To prevent this, it is desirable to ensure surveyed flows are consistent before entry into TRANSYT and it is also necessary to check

for any subsequent flow inconsistencies within a model. TranEd and TRANSYT have facilities to assist with this, including Network Diagram overlays (see [B6.7.2.1](#)) and other visual aids as shown in [Figure 95](#). It is not acceptable to combine flow surveys from different peak periods into the same model.

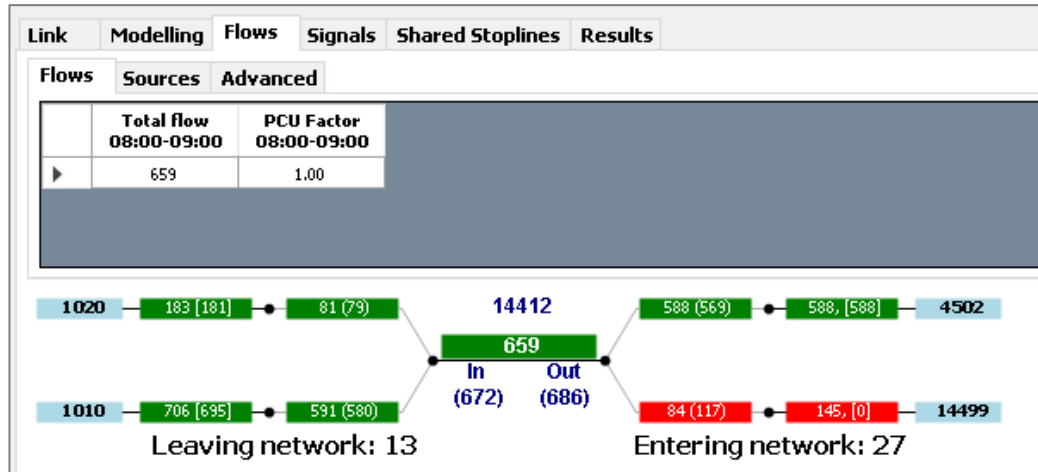

Figure 95: Link flow inconsistency shown in the TI6 flow entry window

Most TRANSYT models are built using stopline flows from classified traffic count surveys. If a model is to be built using flows from an Origin-Destination (OD) survey these will need to be converted into Link-Based flows for entry into TRANSYT, or in TI6 flows can be entered in matrix form (sections [B6.4.7.2](#) and [B6.4.7.3](#)). To convert an OD matrix into Link flows requires the creation of a lane-flow diagram based on the network layout. This can be completed manually or by using bespoke software such as JCT's FlowRound. Section [B2.3.4.1](#) highlights basic guidance for reconciling surveyed traffic flow differences within a modelled network.

6.4.7.2 Local OD Matrix Flow Entry ^[TI6]

In TI6, local OD Matrices can be used for flow entry at a junction level where OD flow information is available. In order to use a Local OD Matrix, Locations need to be specified for all local OD pairs and flows entered for each traffic type (Normal, Bus and/or Tram). Paths represent all available Link or Traffic Stream sequences between each pair of defined Locations, and can be generated automatically by TRANSYT using the 'Calculate Paths' or 'Auto Calculate' options, or can be manually defined if necessary.

It should be noted that a Local OD Matrix is not intended for use over a large area – it should be limited to individual junctions or groups of closely associated junctions where behaviours of individual junction movements are well known (examples include a signalised roundabout, SCOOT

multinode or junctions in close proximity with route-specific queuing behaviour).

The number of possible Paths can become large where a Local OD Matrix covers more than one junction or where there are many possible Link or Traffic Stream sequences between Locations. This will increase model run times, therefore unrealistic or unused Paths should be avoided – these can be deleted manually, or various rules can be applied to prevent unwanted routes being automatically generated, as shown in **Figure 96** and explained further detail in the T16 manual. The number of underlying Links (path segments) is reported in the bottom-right of the T16 application window.

Figure 96: Local OD Matrix flow allocation options

Flows defined in the Local OD Matrix are automatically allocated to the available Paths between OD pairs using one of the following methods:

- **Path Equalisation** – flows equally split between all possible Paths;
- **Lane Balancing** – DoS balanced equally across all entry Links or Traffic Streams (typically representative for individual junctions or roundabouts); or
- **Local Assignment** – flows allocated based on user-equilibrium assignment (used where alternative routes exist through a complex junction).

It is important to check that flows are allocated to Paths in a realistic and representative manner – allocated flows should not just be assumed to be correct. Any discrepancies between the entered OD flows and allocated flows can be seen in the Resultant Flows tab, where differences will be highlighted.

Where necessary, flows on individual Paths between OD pairs can be further refined by adjusting the Allocation Type for each of the defined traffic types. The following Allocation Types are available, as shown in **Figure 97**:

- **Normal** – flows allocated using the defined automatic flow method;
- **Fixed** – user-entered flow allocated to the Path;
- **Percentage** – user-specified percentage of the total OD flow; and
- **Disabled** – no flows will be allocated to the specified Path.

Local Matrix		Entry Flows		Resultant Flows		Journey Time		Locations		Paths	
All		Normal		Bus		Pedestrians					
	Path	ID	Description	Allocation type	Percentage (%)	Fixed flow (PCU/hr)	Normal Calculated Flow (PCU/hr)				
	1	1		Normal			124				
	2	2		Fixed		50	50				
	3	3		Percentage	30		48				
	4	4		Disabled			0				

Figure 97: User-specified flow Allocation Types for individual Paths

Where multiple Local Area Matrices exist within a model, care needs to be taken at matrix boundaries to ensure that any lane-specific arrival patterns are maintained across each boundary. If single Locations are used across multiple Links or Traffic Streams then flows will be allocated according to the chosen allocation method (for example they may be evenly split). In order to maintain lane-specific flows, multiple Locations should be used to distinguish between flows entering and exiting in specific lanes, as shown in **Figure 98**.

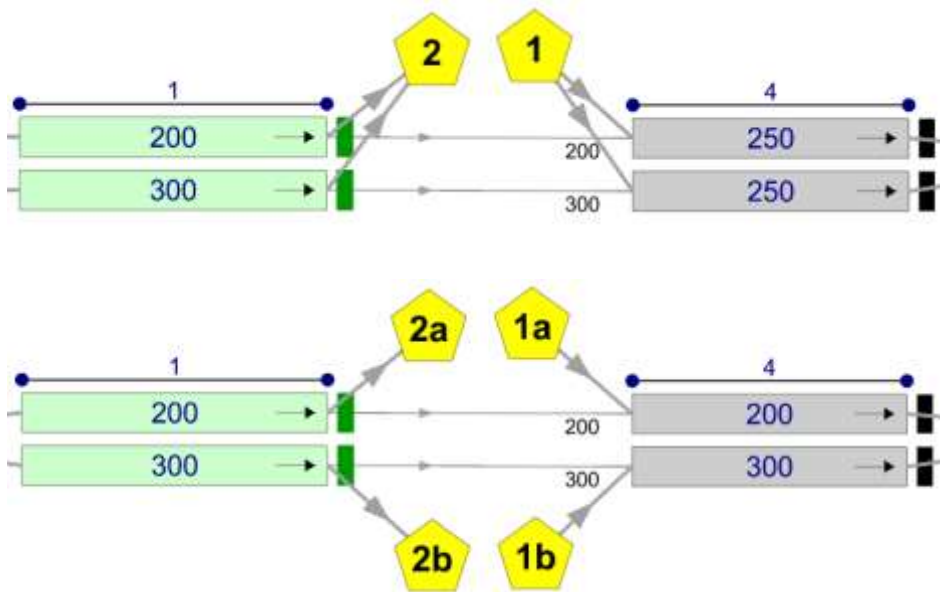

Figure 98: Maintaining lane-specific flows at Local Location boundaries

6.4.7.3 Wide Area Flow Matrices ^[T16]

In T16, Wide Area Flow Matrices can be used to automatically populate Local Area Flow Matrices within a model where an OD is known over a larger area, for example when derived from a Highway Assignment Model (see **B5 Highway Traffic Assignment** for more details) or an ANPR survey. As for Local Area Flow Matrices, Wide Area Locations need to be specified for all origins and destinations over the wider area and flows entered for each allowed traffic type (Normal, Bus and/or Tram).

Each Wide Area Location needs to be associated with a Local Area Location on an entry to (or exit from) the modelled network. If a Wide Area Location is mistakenly associated with a Local Area Location internal to the modelled network then flows will not be correctly assigned. While it is possible to use Multiple Wide Area Matrices with a single network, their areas should not overlap.

Unlike Local Area Flow Matrices, with a Wide Area Flow Matrix there is no choice of flow allocation method – Wide Area Flows are allocated through Journey Time User Equilibrium assignment. This utilises an iterative process to ensure that the cost to traffic in terms of journey time is equalised on all routes between OD pairs. Once flows have been entered into the Wide Area Flow Matrix, the 'Assign Flows' button within the Flow Assignment Tool can be used to assign flows to the available Wide Area Paths, which are automatically generated during the Assignment process.

As for Local Area Paths, options are available to limit the Wide Area Paths generated and further refinement of assigned Path flow volumes is possible through adjustment of Assignment Cost Weightings for individual Links / Traffic Streams, as shown in **Figure 99**. Once any options or weightings are changed, the 'Assign Flows' process should be repeated to take account of the changes made. Again, as for Local Area Matrices the Resultant Flows should be checked to ensure that there are no discrepancies between the entered Wide Area Matrix flows and the assigned flows.

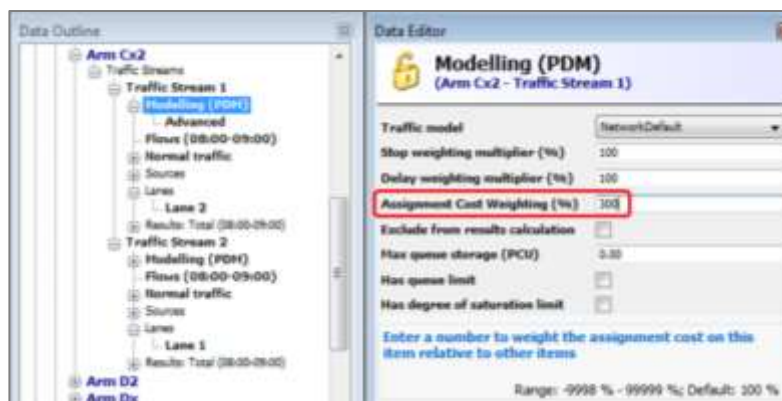

Figure 99: Use of Assignment Cost Weightings to influence assigned flows

Following Wide Area Flow Assignment, relevant Local Area Matrix flows will be overwritten with values from the assignment and Local Path flows updated, except where individual Local Path flows have been fixed by the user.

6.4.7.4 Time-Varying Flow Profiles ^[T16]

Unlike T12 which supports only a single, uniform simulated time period, T16 provides the ability to model multiple time segments within a modelled time period, allowing varying flow profiles to be used (this feature requires Advanced Mode to be enabled). The number of time segments required and their durations can be entered in the Main Data dialog window, as shown in **Figure 100**, or under Network Timings in the Data Editor.

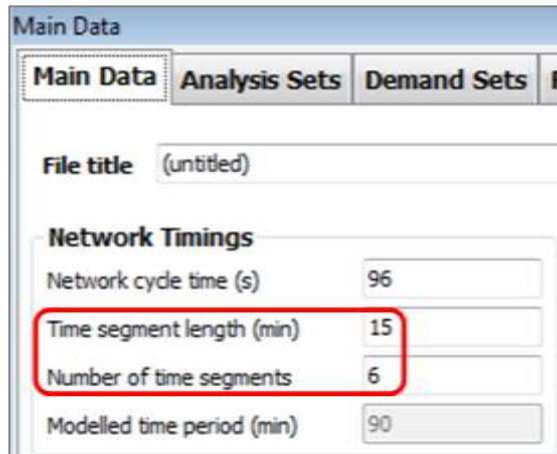

Figure 100: Specifying multiple time segments within a T16 model

For Links, traffic flows for each time segment can be specified using the following options in Link Flows within the Data Editor:

- **FLAT** – a uniform flow is assumed across all time segments, as in T12;
- **DIRECT** – a constant flow is specified for each separate time segment; or
- **GAUSSIAN** – a normal distribution is applied to the entered total flow, representing an assumed typical peak flow profile (similar to 'ODTAB' in PICADY / ARCADY or 'ONE HOUR' in Junctions).

For Traffic Streams and Links using Matrix-Based flow entry, the above choice is not available and flows must be specified separately for each time segment (effectively equivalent to the DIRECT method). This is achieved through use of a separate flow matrix for each time segment.

Specific time segments can be individually selected using the Time Segment drop-down menu in the top-right of the TRANSYT application window, as shown in **Figure 101**. This allows segment-specific data entry in the case of Matrix-Based flows, and viewing of model results for specific time segments with either flow entry method. A further 'Summary' option is available, which shows aggregated model results over the entire modelled time period where available.

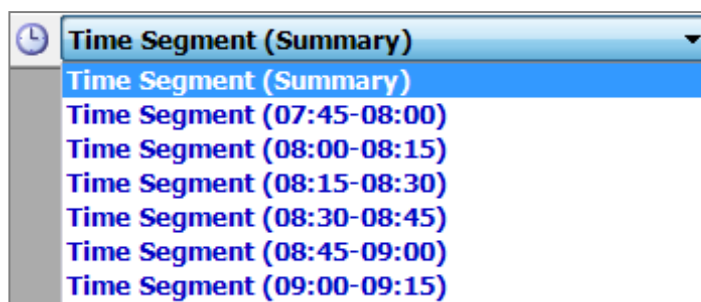

Figure 101: Time Segment drop-down selection menu

It should be noted that when optimising a model containing multiple time segments, TRANSYT optimises performance for the whole modelled time period and not just for the worst performing time segment. The single set of optimised signal timings is applied across all time segments, which may therefore require further refinement if performance in the worst performing time segment is considered unacceptable.

6.4.8 Public Transport

In a Link-Based network, buses should be modelled using Minor Links (see [B6.4.4.3](#)) where they share the carriageway with general traffic, and Major Links where they are segregated in dedicated bus lanes. This Link structure allows public transport delay and optimisation to be assessed separately from general traffic. Whichever Link type is used, the Links should be specified as dedicated Bus Links.

In TI6 separate Traffic Streams are not required for buses, however the Traffic Stream's traffic type must be set to include all relevant traffic categories that are able to use it (Normal, Buses and/or Tram), as described in section [B6.4.4.6](#). Once these have been defined, flows for each traffic type can be entered within the relevant OD Flow matrix ([B6.4.7.2](#)).

It should be noted that one of the limitations of the Cell Transmission Model in TI6 is that it cannot model traffic within a single Traffic Stream or Link Share as having different cruise speeds. The CTM is therefore not generally suitable for use where bus stops are present or where there is a significant difference between observed cruise times for buses and general traffic during the period being modelled. In these cases the Platoon Dispersion Model should be used (section [B6.4.3](#)).

Where bus flows are specified on a Link or Traffic Stream using the PDM, the following parameters need to be entered:

- Bus cruise speed, in kph (regardless of whether cruise speeds or cruise times are specified in the TRANSYT program options); and
- The time stationary on each Link or Traffic Stream, representing the total dwell time at any bus stops.

Note that the 'Tram' traffic type in TI6 does not have a dedicated traffic model and is based on same traffic model as buses, however the Tram's dispersion parameters, cruise speed and stopped times can be specified separately from buses. In the absence of real trams, the 'Tram' traffic type can be used to represent any other discrete traffic category of interest with appropriately specified dispersion parameters and cruise speed / stopped time parameters.

If no bus stops are present then the stationary time should be left as zero. If more than one bus stop is visited on a Link the stationary time should represent the sum of all bus stop dwell times, with an additional contribution representing acceleration and deceleration periods at the additional bus stops (TRANSYT already accounts for bus acceleration and deceleration due to the first bus stop). Where bus stops are not visited by all passing bus routes, or dwell times at the same bus stop vary significantly between routes, route-specific cruise times can be modelled using multiple Minor Links in a Link-Based network or with path-specific cruise times when using Traffic Streams.

Bus stop dwell times should ideally be surveyed on-street or derived from iBus journey time data, particularly in areas of significant interest. It may however be agreed that estimated default values are acceptable in other areas where bus flows are low or where bus performance is not being reported on.

If bus lanes do not extend all the way to the stopline, a bus set-back is created which allows general traffic to use a short lane in front of the bus lane (for example for left-turning vehicles). This should be modelled as a flare for general traffic with a separate Link or Traffic Stream for buses. The bus Link / Traffic Stream should have its start lag (or Start Displacement Time in TI6) increased by the average time taken for queued vehicles stored in front of the bus to clear the signal stopline, which should be measured separately for each modelled period as it may vary by time of day. Note that for TI6 start / end displacements are applied to controller phases rather than directly to Links as in TI2, therefore a duplicate 'dummy' phase should be created for delayed buses with appropriate start / end displacement adjustments so that general traffic controlled by the original phase is not affected.

As TRANSYT is based on average signal timings during a typical cycle, dynamic control strategies like SVD Bus Priority cannot be explicitly modelled. Instead their effect can only be represented by the average signal timings within the model. If detailed modelling of dynamic bus priority is required then microsimulation should be considered.

6.4.9 Pedestrians

In TI2, pedestrian Links should be placed in the model wherever there are signalised or significant priority crossings. Since TRANSYT cannot model the complexities of priority crossings, their impact should be accounted for through use of dummy signalised staging in order to quantify their impact on capacity.

TI2 is not typically used for detailed modelling of pedestrians, therefore when entering Link data for pedestrian Links it is common to use standard values, such as saturation flows of 10000PCU/hr and dummy flows of 10 PCU. Link lengths can be entered from site-measured crossing distances, and cruise times calculated by dividing Link length by an assumed pedestrian walking speed of 1.2m/s. Pedestrian Links should be specified as Bottleneck Links, with stop and delay weightings typically set to -9999 so that they do not affect network PI values.

In TI6, Pedestrian Links can no longer be created and instead Pedestrian Crossing objects should be used to represent signalised crossings and significant priority crossings. It is no longer necessary to enter dummy flows for pedestrians in TI6, although these can be added for simplified analysis of pedestrian performance. To specify pedestrian flows, each side of the crossing should be associated with a dedicated pedestrian OD Location or connected to an adjacent Pedestrian Crossing object, and flows assigned via a pedestrian flow matrix. Dummy saturation flows should be entered for each side as for TI2, and crossing distances entered with a pedestrian cruise speed of 1.2m/s (4.32kph)⁹³. Where pedestrian flows are entered but not intended for optimisation, the setting 'Exclude pedestrians from results calculation' should be enabled in the model's global Traffic Options (this can also be enabled locally for each side at individual Pedestrian Crossing objects).

TI6 can be used for more detailed modelling of pedestrian delay if suitable pedestrian survey and saturation flow data is available. A 'Walk on Red' model also exists that treats the pedestrian green and blackout periods as effective green, with gap-acceptance occurring at other times. Non-compliance with pedestrian signals is not typically modelled however and specialist guidance should be sought before considering its use. Where detailed pedestrian modelling is required, consideration should instead be given to the use of dedicated pedestrian microsimulation modelling software as described in Chapter **C3** on **Pedestrian Modelling**.

⁹³ 1.2m/s represents the pedestrian walking speed typically recommended for signal design by the DfT. For detailed modelling of pedestrian delay, a more representative average value may be considered appropriate, which should be verified on site (the default value in TI6 is 1.5m/s).

6.4.10 Cyclists

For advice on the modelling of cyclists in deterministic modelling packages such as TRANSYT, refer to the detailed guidance in Chapter **C2** on **Cyclist Modelling**.

For Link-Based networks in T12 / T16, cyclist flows can be directly entered on Links where appropriate based on their PCU contribution, and distinguished from other flows through use of dedicated Links or Link Shares. This allows the use of separate cruise times from vehicular traffic to more realistically represent observed cyclist speeds.

For Matrix-Based flow allocation in T16, whether using Links or Traffic Streams, it is not possible to distinguish cyclists from private vehicles on individual Paths when using the Normal traffic type. Link Shares or dedicated Links / Traffic Streams can still be used with suitable cruise times, however it may be necessary to fix cyclist flows on these Paths. In order to model mixed vehicles and cyclists on individual Paths, another unused traffic type could be used to represent cyclists, such as Trams - this would however require careful modification of the Tram dispersion parameters and specialist advice should be sought.

6.5 Base Model Validation

Model outputs for individual Links / Traffic Streams (discussed further in section **B6.7**) should be compared with corresponding survey data in order to validate that the model has been calibrated to an acceptable degree of accuracy.

Validation criteria for TRANSYT Base models submitted to TfL are defined in TMAP, as discussed in **B2.1.5**. At the time of publishing, these are currently⁹⁴:

- DoS within 5% of observed values;
- DoS for Links upstream of pedestrian crossings within 10% of observed values; and
- Observed Cyclic Flow Profiles (CFP) for critical Links showing similar peaks, dispersion and spacing.

6.5.1 Flow Inconsistencies

The validation of a calibrated model can only occur once traffic flows have been introduced in to the TRANSYT model. A validated Base model, submitted during TMAP Stage 3, should not contain traffic flow discrepancies unless previously agreed with NP.

Where there is a discrepancy in traffic flows the modeller should examine the raw flow data used for modelling. It may be necessary for the model developer to adjust modelling inputs from the calibrated model in order to validate against on-site surveyed conditions. However it is not acceptable to progressively adjust model inputs to achieve validation. Any changes should be justifiable, based on sound engineering principles and documented in accompanying validation reports.

6.5.2 Oversaturation

Base TRANSYT models should not show results for DoS over 100% where stopline traffic counts have been used rather than demand flows, such as at entries to the network. All surveyed stopline traffic should clear associated stoplines within TRANSYT, therefore if a Link or Traffic Stream with surveyed stopline flows has a DoS over 100% then discrepancies may exist for one or more of the following parameters: saturation flow, Link / lane structure, green time and/or stopline flow.

94 Latest MAP requirements are available at <https://www.tfl.gov.uk/trafficmodelling>

6.5.3 Excess Queues

While queue lengths are not considered suitable criteria for validation purposes (as discussed in sections **B2.3.4.4** and **B2.4.2**), excess queues are highlighted in TRANSYT outputs (section **B6.7.1**) and indicate where queues exceed available storage capacity on individual Links or Traffic Streams. Where this occurs, the following parameters should be assessed to determine whether they are correct – green times, offsets, saturation flows and traffic flows. If these parameters have been correctly modelled, it may be necessary to adjust modelled signal timings to remove excess queues, as carried out when accounting for exit-blocking through appropriate representation of Underutilised Green Time (section **B6.4.5.6**).

6.6 Proposed Model Development

Proposed TRANSYT models should be created from a validated Base model, or Future Base model if following the Three Stage Modelling Process described in **B2.1.4**. The Proposed models should be modified with the minimum number of changes necessary to fully describe the Proposed scenario.

This section details considerations to be made when creating a Proposed TRANSYT model.

6.6.1 Future Base

As described in **B2.1.4.2**, the Future Base model includes all likely network changes expected to occur between the Base year and the year being examined in the proposal, excluding the proposed scheme under consideration.

It is built from the validated Base model with the minimum number of changes necessary to include any new schemes falling within the TRANSYT model boundary. The guidance in the rest of this section applies equally whether creating the Future Base or Proposed model.

6.6.2 Proposed Layout

Modifications should only be made to elements of the validated Base model or Future Base model that reflect the changes required as part of the scheme designs. Further amendments to the model to make a model operate within capacity are not acceptable. If a Proposed model will not operate without additional changes it is an indication that the design is not viable or the Base model may not be fit for purpose.

During scheme design, model outputs should be used to assess the scheme's effectiveness and, if necessary, consider suitable design changes prior to full re-optimisation of signal timings as described in **B2.5.6.2**.

Where flows are predicted to change following implementation of a scheme, effective flare lengths should be estimated using QueProb or LinSat when using TI2, and in TI6 if using Quick Flares.

Cruise times should not be changed to reflect a proposal that is expected to reduce queuing and delay since cruise times represent free-flow conditions. However, cruise times should be re-measured if proposals are expected to involve changes that impact cruise speed, such as a reduction in parked vehicles, introduction of speed reduction features or stopline-to-stopline distances being changed.

When modelling new proposals, the treatment of ‘funnelling’ and ‘fanning’ traffic can become a possible source of error. ‘Funnelling’ occurs when a greater number of lanes at one signal-controlled stopline exit into a fewer number of lanes downstream, while ‘fanning’ represents the opposite scenario, where fewer lanes upstream flow into more lanes downstream. This behaviour should be reflected in the modelled layout where funnelling forces lanes to behave like flares or with modified capacity where fanning results in underutilisation of downstream stoplines. However, this would only be necessary where downstream lanes are grouped together, and not if individual lanes are modelled.

Existing Link and Traffic Stream numbering within a validated Base model should not be changed within a Proposed model unless necessary. New items should be added using an appropriate numbering / naming convention and highlighted within the proposal report.

6.6.3 Proposed Flows

The methodology for determining and implementing Proposed flows should be agreed at both the Base scoping meeting during MAP Stage 1 (section [A4.4](#) and [B2.1.5.1](#)) and Proposal Scoping Meeting during MAP Stage 4 (section [A4.5](#) and [B2.1.5.1](#)) to ensure that the most appropriate methodology is used.

Future year flows of cyclists and pedestrians are typically agreed on a project-specific basis. Refer to Chapter [C2](#) on [Cyclist Modelling](#) and Chapter [C3](#) on [Pedestrian Modelling](#) for further details.

In TranEd separate Flow Groups can be used for Base and Proposed flows that use the same network structure. In TI6, Proposed flows can similarly be separated from Base flows for clarity using individual Demand Sets. If necessary these can be combined within a Compound Demand Set and applied to the Analysis set representing the Proposal (section [B6.3.5](#)).

6.6.3.1 Tactical Modelling

As explained in [B2.5.2.2](#), the Three Stage Modelling Process will often lead to traffic flows for TRANSYT models being transferred from tactical modelling. The tactical flows and routing can be transferred directly into the TRANSYT model or they can be used to inform uplift values from the Base model flows. If relevant to the proposals, any assumptions made whilst inputting the Base model flows should be maintained in the Proposed models.

Any changes made to traffic flows or routings in the Base model for validation purposes should be carried across appropriately to the Proposal

6.6.3.2 Public Transport

Any changes to bus routes and service frequencies in the proposals should be included within the Proposed model. This will require manual adjustments to bus flows directly entered on Links or to bus flows entered within relevant OD Flow matrices.

Where any existing routes have been diverted or new routes added, the network structure should be reviewed to ensure that new bus flows can be properly represented and analysed. This may involve use of additional Link Shares or modification of existing Traffic Streams to support the Bus traffic type.

Any changes to bus stop locations or dwell times should be reflected on the appropriate connectors.

6.6.4 Proposed Signal Timings

It is important to ensure that proposed signal designs are audited by a TfL Signals Auditing Engineer to ensure that they meet current TfL standards. Once approved, signal timings in the proposals should be developed and optimised following the methodology and guidance described in **B2.5.3**.

TI2 model submissions should be accompanied by skeleton LinSig models for auditing purposes as described in **B6.2**, to ensure correct representation of proposed signal phasing. Full details of the LinSig phase / TRANSYT Link relationships should be provided, however this is not necessary when using TI6 as controller phases are directly modelled.

Any new Nodes or Controller Streams representing proposed signalised junctions should be numbered using an appropriate numbering / naming system – a recommended approach is a single digit starting at one, rising in increments of one. Where existing Nodes, Links or Traffic Streams are converted in type, for example from unsignalised to signalised, care should be taken to ensure existing data is maintained where applicable.

Existing Node or Controller Stream numbering within a validated Base model should not be changed within a Proposed model unless necessary. New items should be added using an appropriate numbering / naming convention and highlighted within the proposal report.

6.6.4.1 Optimisation

As described in section **B6.1.3**, TRANSYT's traffic models are used to evaluate the overall impact of stops and delay for a network using the numerical monetary value of the Performance Index (PI). The goal of optimisation in TRANSYT is to find a set of signal timings that produces the smallest possible overall PI value, therefore minimising the impact of stops and delay on the network.

The following key steps are detailed in this section, which contribute towards the overall optimisation strategy as discussed and illustrated in **B2.5.3**:

- Initial signal timings;
- Evaluating existing network performance;
- Optimisation algorithms;
- Cycle time optimisation;
- Optimising green splits and offsets; and
- Optimiser constraints and weightings.

Whichever optimisation strategy is used, it should be recognised that TRANSYT is a tool based on a series of approximations, representing a simplified version of reality. While it is possible to influence optimisation according to specific criteria or interests, further manual refinement may be required and the determination of whether timings are optimal ultimately requires engineering judgement. Where time-varying flow profiles have been used (section **B6.4.7**), it is important to remember that TRANSYT optimises timings for the whole modelled time period and not just for the worst performing time segment.

6.6.4.1.1 Initial Signal Timings

TRANSYT requires an initial set of signal timings for every signal-controlled Node or Controller Stream prior to optimisation. These timings are used to generate an initial reference PI value against which subsequent optimisation attempts can be compared.

Since final signal timings after optimisation can be dependent on the initial timings used, the choice of initial signal timings requires some consideration. If optimised timings are expected to be similar to existing timings, then existing timings should be used as a starting point. For a Base model these are typically derived from existing signal timing plans or observed measurements.

Where existing timings are unavailable, or if optimal signal timings are expected to differ significantly from existing timings, TRANSYT can

automatically calculate evenly balanced initial starting timings to reduce the influence of previous timings. This is achieved using the EQUISAT (TI2) or Auto Redistribute (TI6) features, which overwrite pre-existing timings when a full model run is carried out.

To further reduce the influence of specific initial signal timings on optimisation, and potentially find improved optimised timings, algorithms such as Shotgun Hillclimb can be considered.

6.6.4.1.2 Existing Network Performance

The network performance for an existing set of signal timings can be assessed in TI2 by running the model with 'No Optimisation' selected. When doing this, care should be taken to ensure that EQUISAT is not enabled, which would otherwise overwrite existing signal timings.

In TI6 existing network performance can be assessed by performing an Evaluation Run of the model, or a Full Run with optimisation disabled in the model's network options (see [B6.4.2](#)).

6.6.4.1.3 Optimisation Algorithms

The following optimisation algorithms are available in TI2 and TI6, and are specified within a model's network options (see [B6.4.2](#)):

- Hill Climb (TI2 / TI6);
- Shotgun Hill Climb (TI6); and
- Simulated Annealing (TI6).

The default Hill Climb process starts from an initial set of timings and tests whether incremental changes to splits and offsets reduce network stops and delay. Once no further improvements can be found then timings are assumed to be optimal.

In TI6, the additional optimisation algorithms Shotgun Hill Climb and Simulated Annealing are available. The first provides a more thorough Hill Climb evaluation by starting from multiple random signal states, reducing the influence of initial signal timings and increasing the chance of improved optimisation. Simulated Annealing provides further flexibility to test a wider range of possible signal states during early optimisation which is refined as the optimisation progresses.

Ultimately, the choice of optimisation algorithm is a matter of balancing speed against thoroughness. For preliminary analysis the standard Hill Climb process provides the fastest results, however for later modelling stages the additional optimisation algorithms in TI6 can be used to ensure maximum effort to find the most effective signal timings.

6.6.4.1.4 Cycle Time Optimisation

TRANSYT's cycle time optimiser tools can be used to help indicate the most appropriate cycle time for a modelled network.

The internal cycle time optimiser (CYOP) feature in TI2 takes a simplified approach and models each Node as a distinct entity, using timings that give equal DoS to critical approaches, but disregarding the influence of applied groupings, weightings or penalties. CYOP calculates the PI for each Node over a series of cycle times, then highlights where a common cycle time may force a Link to exceed 90% DoS and recommends where double-cycling may be beneficial. When using CYOP engineers should be mindful of junction delay as mentioned in section [B2.5.6.1.4](#).

TI2 and later versions can also generate cycle time graphs to illustrate network performance for a range of cycle times. Unlike CYOP, these are based on full optimisation and include the influence of signal coordination and any applied weightings or penalties. Cycle time graphs can complement the CYOP approach in TI2 as cycle time graphs do not produce double-cycling recommendations, although in TI6 graph options allow them to be manually investigated. While TI2 simply shows network PI values on cycle time graphs, TranEd and TI6 can additionally show network delay and maximum DoS / Practical Reserve Capacity, as shown in [Figure 102](#).

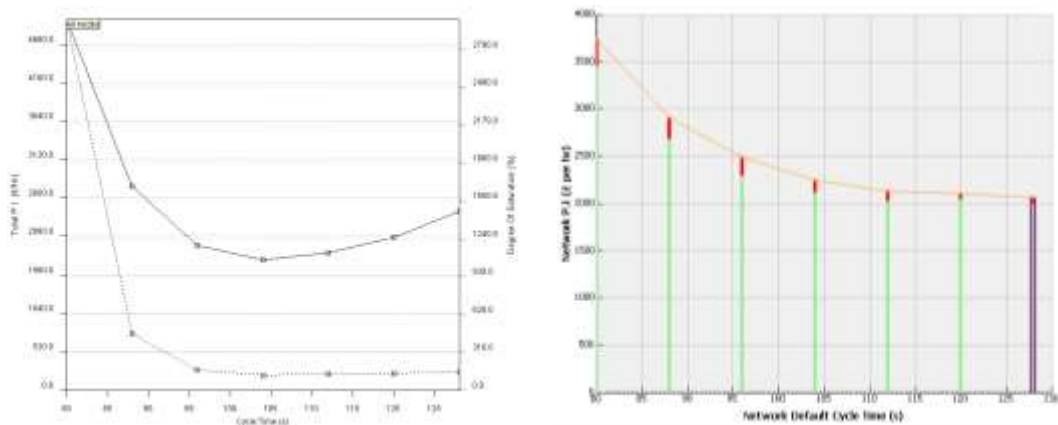

Figure 102: Cycle time optimisation graphs showing PI and saturation information in TranEd (left) and TI6 (right)

Although TRANSYT can illustrate cycle time options, the modeller must ultimately decide the most appropriate cycle time, taking into account factors such as Mayoral transport policies and local network management strategies. Section [B2.5.6.1.3](#) provides guidance on available cycle times and important considerations which may influence cycle time choice.

6.6.4.1.5 Optimising Green Splits and Offsets

During an optimisation run, TRANSYT will optimise signal timings for all Nodes listed in the Node List (TI2) or for all Controller Streams listed in the Optimisation Order (TI6). As specified in a model's network options (**B6.4.2**), signal timings can either be optimised for offsets only, leaving existing green durations (splits) intact, or for both green durations and offsets together.

Further constraints can be imposed to preserve specific offsets between neighbouring signals while allowing others to be optimised. This is particularly important for fixing critical offsets within SCOOT multinodes or UTC / CLF subgroups. Offsets can be constrained using Node Groups in TI2 or Stage Constraints in TI6. Where a Node Group is defined, offsets between all member Nodes are maintained. Offset optimisation can similarly be disabled for individual Controller Streams in TI6, however TI6 Stage Constraints provide finer control by allowing individual offsets to be fixed relative to the start or end of specified stages at neighbouring Controller Streams.

TRANSYT's optimisation procedure is influenced by which stage occurs first in the signal cycle. As the initial start stage may change during optimisation, derived timings may not be exactly the same as those produced by a previous calculation. Modellers should be aware that this effect can sometimes generate different results when repeating back to back TRANSYT optimisations. An initial optimisation should therefore be carried out to balance the network, using EQUISAT or Auto Redistribute if necessary, with subsequent optimisation iterations based on already optimised timings.

Simplified assumptions within some of TRANSYT's traffic models may mean they do not accurately predict the performance of networks operating close to capacity. As a result, after initial signal optimisation, model outputs such as traffic profiles and queue graphs should be reviewed (section **B6.7.1.1**). It is possible to use this information to establish when in the cycle different approaches are likely to suffer from exit-blocking or poor performance.

Once the reasons for a loss of capacity are known and understood new stages in relevant methods of control can be considered and full optimisation repeated. In order for a proposal to consider all underlying traffic management requirements within a proposal it may be necessary to influence TRANSYT during initial optimisation with appropriate penalties and weightings, as covered in the following sections. It may also be beneficial to reiterate optimisation for specific Nodes or Controller

Streams by repeating them in the Node List / Optimisation Order so that they are optimised twice within the same optimisation cycle.

It is important at all stages of optimisation to assess model output to ensure proposed signal timings are fit for purpose relative to the scope of the project and overarching considerations, as outlined in **Part A**.

6.6.4.1.6 Stop and Delay Weightings

Stop and delay weightings are used to apply penalties for stops and delays on Links or Traffic Streams by increasing their cost within the PI calculation used for optimisation. Weighting values are entered as percentages which are directly applied to the costs for specified Links or Traffic Streams when calculating the cost of stops and delays across the network as a whole. A value below 100% therefore reduces the cost of stops and/or delays and a value above 100% increases the cost.

Since TRANSYT will always attempt to minimise the overall network cost (in terms of the PI), these weighting values determine the amount of effort TRANSYT will put into minimising stops and/or delays on the particular Link or Traffic Stream relative to costs incurred elsewhere in the model. Weightings of less than 100% are therefore likely to increase the number of stops and/or delays on the Link if this leads to a reduction in cost elsewhere in the model.

It should be noted that the default value of 0 in TI2 and earlier versions is the same as 100, representing a weighting of 100%. In TI6 however, a value of 0 represents a weighting of 0% and 100 represents 100%. In TI2 and earlier versions, a weighting of 0% is specified as -9999.

6.6.4.1.7 Queue Limits

Queue limit penalties can be imposed in order to discourage the formation of queues on specified Links or Traffic Streams during the TRANSYT optimisation process. In a similar manner to stop and delay weightings, this penalty imposes an additional cost towards the network PI when the average queue on a Link or Traffic Stream extends past a user-defined or calculated value. The two values required for a queue limit are:

- Queue length limit for the Link or Traffic Stream (in PCUs); and
- The penalty to be applied when the Mean Maximum Queue (MMQ) on a Link exceeds the specified queue limit, in pence (TI2) or pounds (TI6).

Queue limits can be useful to prevent the formation of disruptive queues where these are seen to occur, such as on circulating Links within a gyratory, or on short internal Links where queuing can cause wasted capacity within a junction.

It is important to be aware of what the MMQ represents in TRANSYT when deciding on an appropriate queue limit value. The MMQ does not refer to the queue at the end of red, but rather the position reached by the back of the queue as the queue discharges, in other words the furthest point at which a queue delays newly arriving traffic. The MMQ is therefore the mean number of PCUs that have queued up to the time when the back of the queue finally clears. As discussed in section **B6.4.3.1**, the simplified queuing model within PDM does not reflect realistic driver behaviour as vehicles approach a queue. Consequently, the time at which the maximum queue occurs is generally later in TRANSYT than on street.

The MMQ value may statistically be exceeded in 50% of cycles during the period being modelled. Similarly, for over-saturated Links the MMQ will be the mean of a queue that is increasing over the modelled period. This means that the queue on-street at the end of the period being modelled can be up to twice the MMQ provided in the model output in extreme cases. If time-varying flow profiles are used in Tl6, queue values can be seen at the end of each modelled time segment in addition to the MMQ for the whole modelled period.

When specifying a suitable queue length limit it is necessary to make an allowance for queue length variation above the MMQ, so that the queue on-street will never exceed the maximum allowable value as determined by junction layout. A queue limit of half to two-thirds of the actual storage capacity of a Link is often used, so that the Link not only accommodates the MMQ, but also has sufficient extra storage space for more extreme queues that may develop.

6.6.4.1.8 Degree of Saturation Limits ^[Tl6]

Degree of saturation limit penalties can be used in order to favour timings that keep DoS on a specified approach above or below a user-defined value, in a similar fashion to queue limit penalties. When the DoS on the approach exceeds the nominated value, a user-defined Excess Degree of Saturation Penalty can be applied. Similarly, if DoS falls below the specified value a user-defined Low Degree of Saturation Penalty can be applied. The applied penalties need to be suitably severe to have an appreciable effect, however, while they can influence final timings, there is no guarantee that DoS limits will always be satisfied.

6.6.4.2 Demand Dependency

When calibrating demand dependency levels in a Proposed model it should be carefully considered whether there is reason to believe they will change from the Base or Future Base model. Where considered necessary, a suitable methodology should be determined to ensure that any estimated demand levels are appropriate. Assuming full demand as a 'worst case' could in fact mask a capacity issue downstream so a judgement on the expected demand should be agreed and documented. For further information refer to [B2.5.2.3](#).

6.6.4.3 Underutilised Green Time

Where adjustments have been made in the validated Base model to reflect Underutilised Green Time (UGT), consideration should be given to the cause of the UGT before determining whether any modifications are appropriate or necessary in the Future Base or Proposed models. If unsure whether to amend Base UGT values, it is recommended that the MAE is contacted to determine the best approach. For further information refer to [B2.5.6.1.1](#).

6.6.4.4 Saturation Flows

Saturation flows should only be changed from the Base model if there is clear evidence that they would be different in the Proposed model. Reasons for this may include:

- A new junction or major layout change;
- A change in lane width; or
- A change in flow volumes for particular turning movements.

If any of these apply then RR67, with an appropriate local factor (section [B2.3.9.1](#)), should be used to implement new saturation flows using the methods described in section [B6.4.4.6](#). The reasoning behind any changes must be documented in the modelling report.

6.7 Model Outputs

TRANSYT can provide a number of outputs to help understand model results and modelled network behaviour. These allow analysis and refinement of signal timings to improve operation and minimise adverse impacts on-street, as required during proposal fine tuning (**Figure 20**).

Model results can be obtained for the entire network, individual Links / Traffic Streams or grouped items of interest. In TI2 it is possible to define specific routes through a network to examine performance statistics for a particular pathway or vehicle group. In TI6, Collections can similarly be defined to provide aggregated data for grouped network elements, such as those representing junctions, routes or specific vehicle groups.

Available TRANSYT model outputs can be broadly distinguished as being predominantly numerical or graphical in nature:

6.7.1 Numerical / Table-based Outputs

In TI2, the model input / output file (*.prt) mentioned in section **B6.3.3** is produced whenever a TI2 model is run. The file consists of a structured fixed text format, with input data categorised according to 'card types' (section **B6.3.3**). Model outputs include optimised timings and performance predictions for individual Links as well as the whole network.

TranEd and later versions of TRANSYT, including TI6, allow user-configurable reports to be generated, containing input and output data of interest as well as simple images. TI6 also provides a Network Summary when run, providing an overview of network results and the worst performing locations in the network.

The model input / output (*.prt) and generated report files form a comprehensive reference for checking models, understanding their behaviour and optimising overall performance. Their use is recommended and documented further in the TRANSYT Model Auditing Process (TMAP), detailed in section **B2.1.5**. Key model outputs include initial and optimised signal timings, Link / Traffic Stream predictions for DoS, MMQ (section **B6.6.4.1.7**), PI, average excess queue and the separate components of delay (**Figure 19**). Additionally, overall network summary data is available for total distance travelled, total monetary value for stops and delay, mean journey speed and total network PI, although this data should not be used to assess the merit of proposed signal timings in isolation.

Model outputs can also be used to check for errors, inconsistencies and sources of poor network performance. The following symbols are used to highlight Links or Traffic Streams with potential issues:

- The 'less than' (<) symbol indicates that flow into a Link or Traffic Stream has been reduced by more than ten percent. This may indicate that an upstream junction has become over-saturated and resulted in downstream flow starvation. In this case upstream Links or Traffic Streams should be checked to identify the flow bottleneck as starved Links will not validate against measured data;
- The 'plus' (+) symbol highlights that an excess queue has formed in the model, with the average queue length exceeding storage capacity on the indicated Link or Traffic Stream. These should be checked to ensure that signal offsets are not generating artificial queues and to ensure that adequate upstream stacking capacity exists. Where this is not the case upstream signal timings should be adjusted to relocate the queue to a more appropriate location, either through a preferred traffic management strategy or through representation of Underutilised Green Time at upstream signals. Queue limit penalties (discussed in section **B6.6.4.1.7**) can also be used during optimisation to deter TRANSYT from forming queues in undesirable locations; and
- TRANSYT estimates storage capacity as a function of Link / Traffic Stream length and saturation flow, although this value can be overridden by a user defined maximum queue storage value if the TRANSYT estimate is considered to be overly optimistic.

Traffic Stream Results

Arm	Traffic Stream	Name	SIGNALS			FLOWS		PERFORMANCE			
			Traffic node	Controller stream	Phase	Calculated flow entering (PCU/hr)	Calculated sat flow (PCU/hr)	Actual green (s per cycle)	Wasted time total (s per cycle)	Degree of saturation (%)	Practical reserve capacity (%)
A	1	(untitled)	1	1	A	100	1800	8	0.00	25	265
Ax	1	(untitled)				430	Unrestricted	40	30.00	0	Unrestricted
B	1	(untitled)	1	1	B2	50	1800	22	0.00	5	1783
	2	(untitled)	1	1	B1	380	1800	8	0.00	94	-4
Bx	1	(untitled)				150	Unrestricted	40	28.00	0	Unrestricted
C	1	(untitled)	1	1	C1	50	1800	22	0.00	5	1783
	2	(untitled)	1	1	C2	100	1800	9	0.00	22	305

Figure 103: Example of model results shown in the TI6 Report Viewer

6.7.1.1 Model Data Comparison Tool [TI6]

TI6 has a facility to compare model input and output data for specified Analysis and Demand Sets, which can be accessed from the 'Tools / Compare Files or Data Sets' menu option. This can be useful when auditing models to determine key changes between model submissions. The compared data can either be from separate Analysis / Demand Sets within the same model file, as shown in **Figure 104**, or from different files.

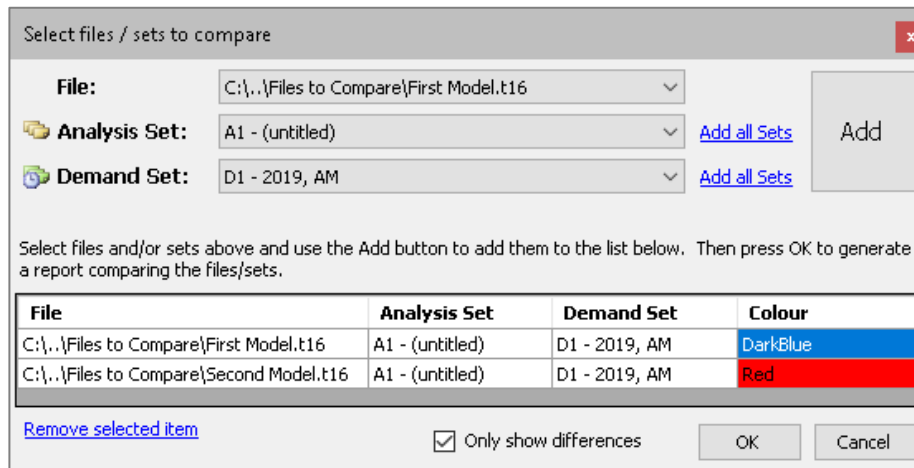

Figure 104: Specifying TI6 model data for comparison

Once the relevant Analysis / Demand Sets are specified for comparison, model input and result data is shown in the Report Viewer, with differing values between the compared sources displayed adjacently and colour-coded as shown in **Figure 105**. It is important to ensure that evaluation runs are performed prior to running the comparison tool to ensure that all displayed model data values are up to date.

Traffic Streams

Arm	Traffic Stream	Name	Description	Auto length	Length (m)	Has Saturation Flow	Saturation flow source	Saturation flow (PCU/hr)	Is signal controlled
A1	1								
B1	1								
C1	1								
xB1	1								
11	1							2274 1315	
x11	1								
13	1							2244 899	
x13	1								
15	1							1249 1490	

Figure 105: Highlighting of model differences within the Report Viewer

6.7.2 Graphical Outputs

In addition to table-based outputs, graphical outputs can also be provided by TRANSYT to aid analysis of model behaviour and results. These include:

6.7.2.1 Network Diagram Overlays

TI2, TranEd and TI6 allow many model results and calibration parameters to be displayed directly on the Network Diagram, including DoS, queues, storage utilisation and flow information. This is typically the simplest way to quickly assess network performance following a model run. Further options include animation of signal states and queues / occupancy during a typical cycle.

Where time-varying flow profiles have been used in TI6, the Time Segment drop-down selection menu also allows displayed data to be shown at various points during the modelled time period, in addition to an overall summary of the entire modelled period.

An example of a Network Diagram Overlay in TI6 is shown in [Figure 106](#), displaying queue and flow information.

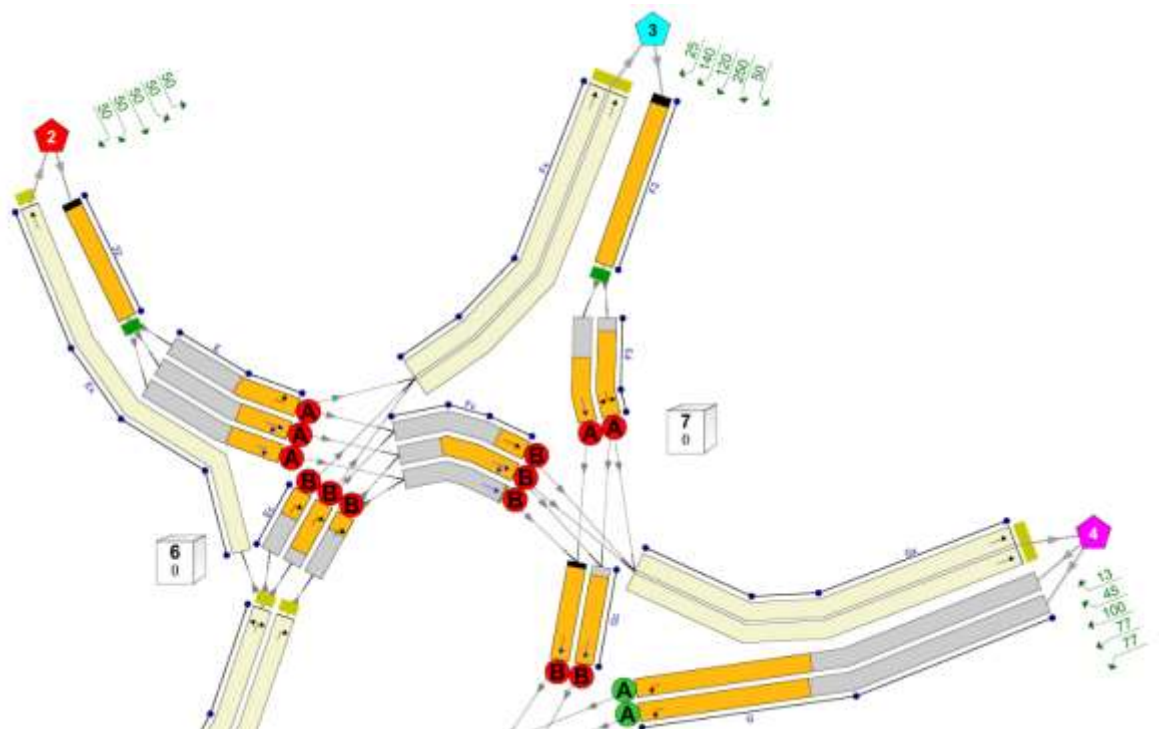

Figure 106: TI6 Network Diagram Overlay showing queue and flow data

6.7.2.2 Queue and Flow Graphs

TRANSYT can produce histograms of queues and flows for individual Links or Traffic Streams, showing the number PCUs queuing, arriving or discharging at a signal-controlled stopline during a modelled cycle.

A queue graph shows both the rate of discharge from the front of the queue during green and the distance of the back of the queue from the stopline throughout the cycle, as shown in **Figure 107**. TRANSYT forms queues based on three components of delay – uniform, random and over-saturation (illustrated in **Figure 19**).

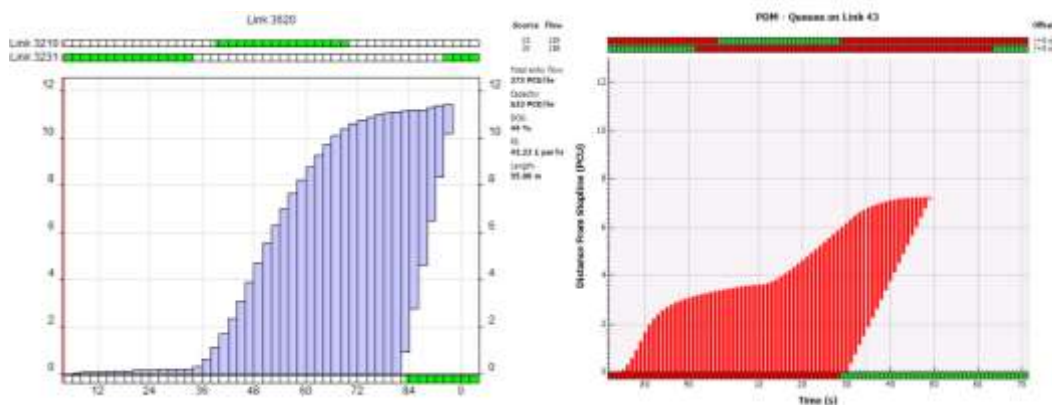

Figure 107: Uniform queue graphs, viewed in TranEd and TRANSYT I6

TRANSYT queue graphs display only the uniform component so should not be used instead of excess queue calculations to predict where queue storage problems may occur. The facility remains useful as it can highlight queuing occurring during green periods, this would be where flow along a Link is greater than saturation flow.

Cyclic Flow Profile (CFP) graphs show the traffic flow rate (in PCU/hr) across a stopline at different time increments during the cycle, as shown in **Figure 108**. These examples combine both the 'In Profile' (traffic arriving at the stopline) and 'Out Profile' (traffic discharging from the stopline) in one view, though they can be viewed independently in T16.

CFPs are useful for assessing offset progression between stoplines as the timing of platoon arrival and queue discharge can be compared between upstream and downstream stoplines.

The different movement profiles within a CFP can be analysed to understand the amount of spare stopline capacity available at different points within the cycle. For example, areas of the CFP in **Figure 108** use the following colour key:

- **Dark green / blue** – previously delayed vehicles discharging from a queue;
- **Light green** – vehicles arriving during a green signal; and
- **Red** – vehicles arriving during a red signal.

The CFP also provides an indication of the Mean Modulus of Error (MME) for the Link or Traffic Stream. MME is a numerical value between zero and two, indicating how bunched a travelling platoon remains as it progresses along a Link / Traffic Stream. The MME is an important parameter when deciding whether a particular Link / Traffic Stream should be coordinated with an upstream neighbour - a higher value indicates potential benefits in coordinating signal timings, as platoons remain clearly defined and are therefore more likely to benefit from offset progression. A value of MME below 0.3 suggests there may be little benefit in stopline coordination, with a value of zero indicating a uniform arrival pattern. It is important to remember that MME is a theoretical concept, because TRANSYT can only model platoon dispersion due to different vehicle speeds and not mid-Link friction caused by parking, loading and minor sinks or sources.

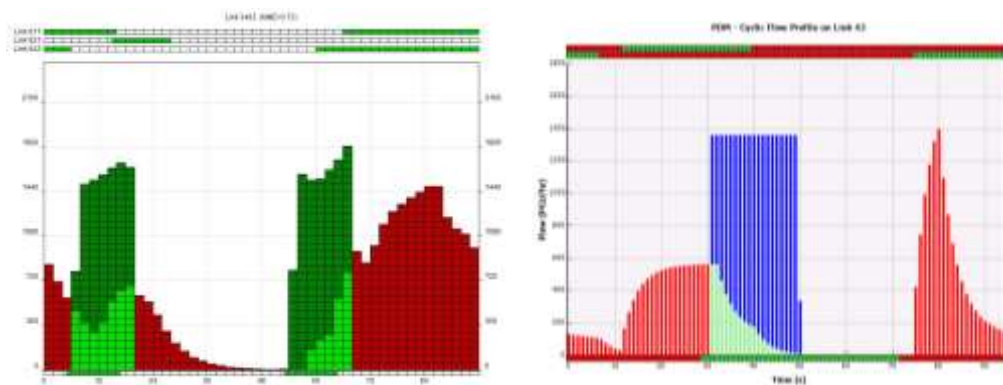

Figure 108: Cyclic Flow Profile graphs, viewed in TranEd (left) and TRANSYT I6 (right)

6.7.2.3 Performance Index Graphs

A PI graph (**Figure 109**) can be used to indicate the likely impact to Link / Traffic Stream PI following a change in signal offset between upstream and downstream stoplines. The histogram plots the Link / Traffic Stream PI on the Y axis against the offset-difference on the X axis. The graph illustrates how PI may vary if the offset-difference is altered by an amount varying

between zero and the user-defined cycle time. Generally, the lower the PI the better the coordination between associated signalised stoplines.

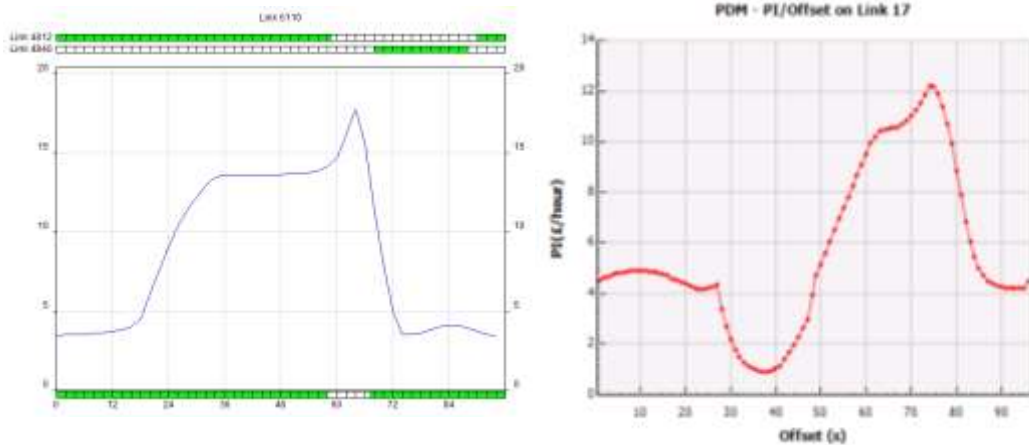

Figure 109: Performance Index graphs, viewed in TranEd and TRANSYT 16

6.7.2.4 Cycle Time Optimisation Graphs

While the CYOP feature in T12 provides table-based outputs for cycle time assessment, TranEd and later versions of TRANSYT can provide visual indications of network performance measures against a user-defined range of cycle times, as shown in **Figure 110**. These can provide a useful initial estimate of the most appropriate cycle time to take forward for further analysis.

Available network performance measures that can be plotted include PI, delay and highest DoS / minimum Practical Reserve Capacity. Further options also allow the investigation of multiple cycling options for individual controllers.

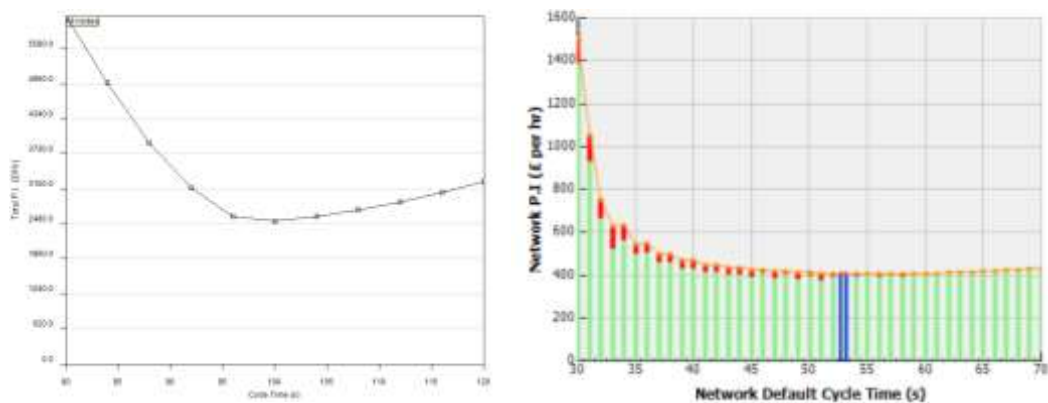

Figure 110: Cycle Time Optimisation graphs in TranEd and TRANSYT 16

6.7.2.5 Time-distance Graphs

A time-distance diagram (**Figure 111**) illustrates platoon progression along a complete route, and can be used when seeking to provide priority for specific movements. The diagram allows a modeller to minimise encountered stops and delays through appropriate modification of successive signal offsets. This can be a useful feature when assessing the output of a proposal to check front and back end progression along a critical route.

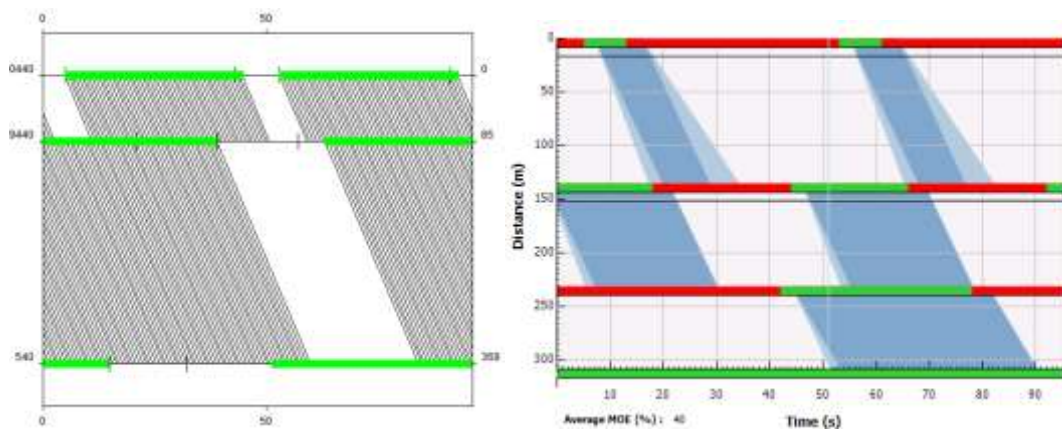

Figure 111: Time-Distance graphs in TranEd and TRANSYT 16

6.7.2.6 Analyser – X-Y and Time Graphs ^[T16]

The Analyser feature in T16 is a useful tool that enables any model output parameter to be analysed in detail. Two types of plots are supported – X-Y Graphs and Time Graphs.

X-Y Graphs, as shown in **Figure 112**, allow any model outputs to be plotted against a user-specified range of a chosen model input. To plot the graph, multiple independent TRANSYT runs are performed to gather the necessary data. This is particularly suitable for sensitivity analysis to determine the influence of key design parameters..

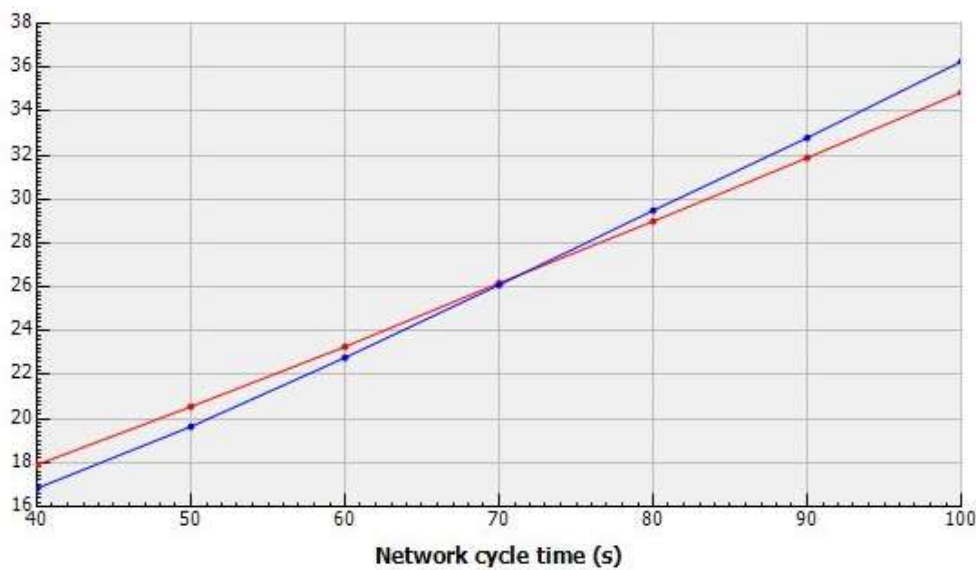

Figure 112: T16 Analyser (X-Y) graph showing P.I. versus cycle time for two Collections

Time Graphs provide the ability to plot specified model output parameters over time, showing any variation during the modelled time period where multiple time segments have been specified. This can be useful to help visualise time-dependent phenomena, for example when the maximum queue or DoS occurs on a critical Link / Traffic Stream, and the resulting impact on wider network performance.

6.7.2.7 Traffic Simulation ^[T16]

When using T16's Simulation Model (discussed in section **B6.4.3.5**), several visualisation options are available that can be used to observe queuing behaviour and assess network performance at any point during the modelled time period. These include:

- Animation of individual vehicles during a single random seed trial (**Figure 113**);
- Display of average queue lengths across all simulation trials; or
- Display of percentile queues, indicating the probability of queue length occurrence as shown in **Figure 114**. Either a specific percentile threshold can be displayed, or shaded percentile queues can be shown indicating the range of queue probabilities observed across all simulation trials.

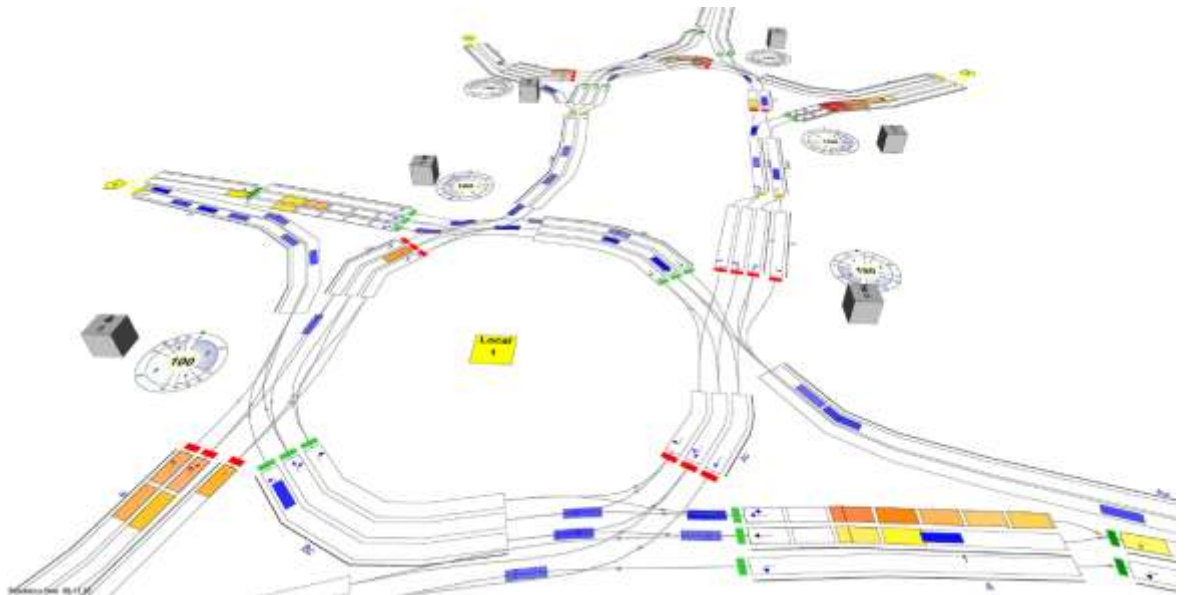

Figure 113: Animation of individual vehicles in a Traffic Simulation random seed trial

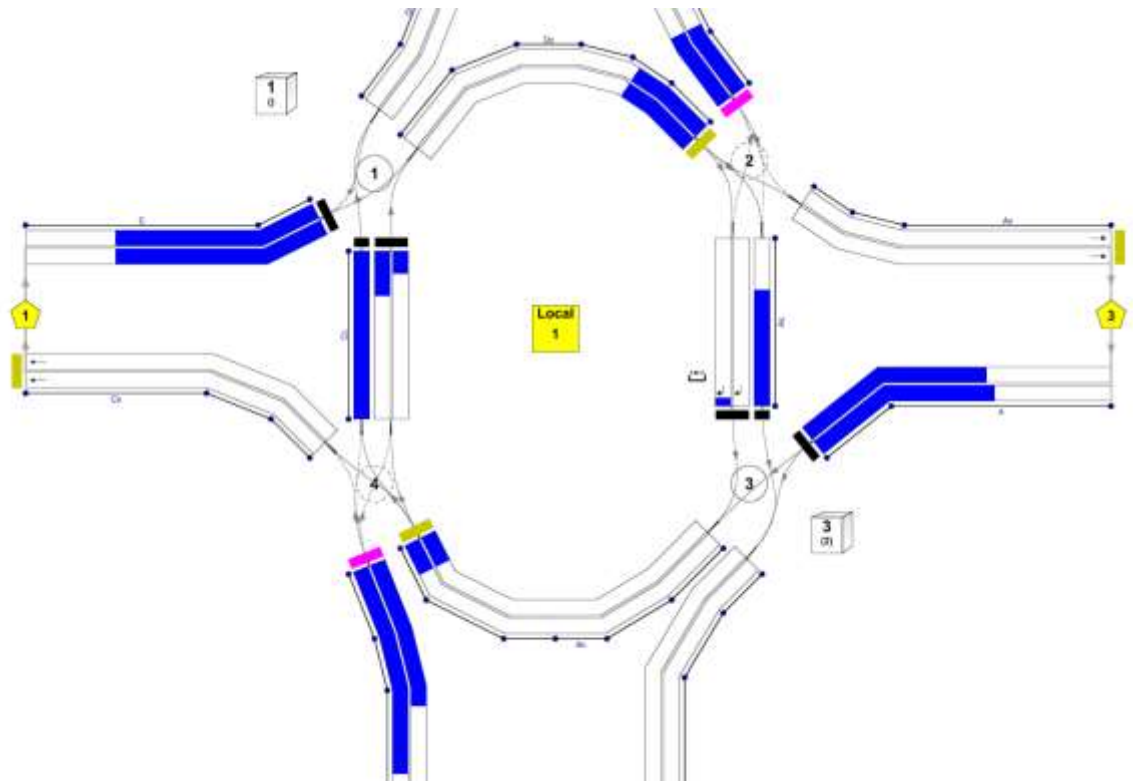

Figure 114: T16 simulation showing 90th percentile queues

Observation of individual vehicles can be helpful to visualise the dynamic nature of queuing behaviour, including associated blocking effects. It is however important to remember that as this represents only a single random seed and other simulation trials may need to be observed.

The Signals Log, shown in **Figure 115**, provides a further visual aid to observe signal operation during the simulation. It can also be displayed with optional queue and flow data for specified Traffic Streams,.

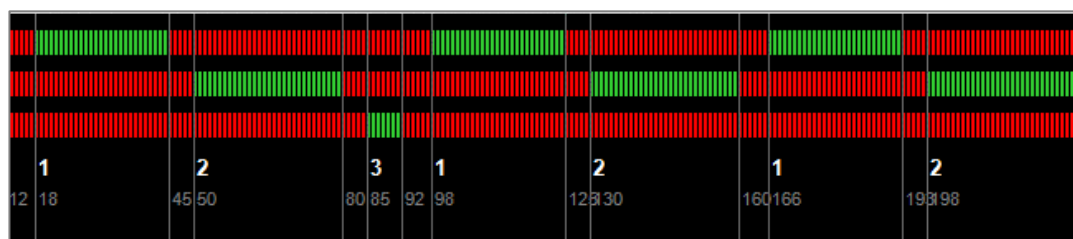

Figure 115: Signals Log in TRANSYT 16

7 Vissim Modelling



7.1 Introduction

This chapter is designed to provide guidance for experienced practitioners when building microsimulation models of London's road network using Vissim. It augments the general modelling guidance given in Chapter **B2** on **Modelling Principles**.

This chapter outlines TfL's recommended approach for microsimulation modelling with Vissim. However, there may be cases where local conditions or project requirements dictate the use of methods which may be different to those outlined. In these situations, NP should be consulted on the planned methodology where modelling will be submitted for approval by TfL.

7.1.1 Introduction to Vissim

Vissim is microsimulation software made by PTV Group (PTV). The name stands for Verkehr In Städten – SIMulationsmodell, which translates as Traffic in Cities – Simulation Model. Vissim uses a Lane-Based network layout and a car-following model to accurately reflect the way vehicles move through junctions and roads and interact with each other. It also has the capacity for lateral behaviour within lanes, which makes modelling features such as cyclists and overtaking possible. Signals can be modelled using either internal fixed-time plans, through Vehicle Actuated

Programming (VAP) which can use detector inputs to vary timings, or through the API, which essentially means that any signal control system can be used as long as an interface has been coded. TfL has the UTC-Vissim Interface, which replicates TfL's Urban Traffic Control system within Vissim (section [B7.4.5.3](#)).

Vissim has traditionally been used to model complex and congested traffic networks, where deterministic modelling cannot provide a realistic representation. In common with other microsimulation software, it is unable to optimise signal timings, and so is usually used in conjunction with deterministic modelling when looking at proposed schemes.

Further information can be found on the PTV Vissim website⁹⁵.

7.1.2 Software Versions

The latest version of Vissim at the time of publishing is Vissim 2021. TfL has developed templates for Vissim with recommended parameters for many Vissim versions, which are available upon request⁹⁶.

There was a significant change to the program user interface between Vissim 5.4 and Vissim 6, which introduced new features and new ways of working. Throughout this section, 'later' versions of Vissim will generally refer to the current (at the time of publishing) state of the software and 'earlier' to previous states. This will often correspond with the change from Vissim 5.4 to Vissim 6, but this is not a fixed rule as the software continues to be developed and new features introduced.

Whichever version of Vissim is chosen for a modelling project must be used for all the models in that project. It is not acceptable to build the Base model in one version and then Proposed scenarios in a more recent version, as the results change between versions.

The version a Vissim model was last saved in can be found at the top of the model file (*.inp / *.inpx) when opening it in a text editor such as Notepad.

7.1.3 Appropriate Use of Vissim

Vissim should be used appropriately to complement analyses provided by traditional traffic optimisation and design tools and often tactical modelling, where the purpose of the modelling requires more detailed

⁹⁵ <https://www.ptvgroup.com/en/solutions/products/ptv-vissim/>

⁹⁶ The latest TfL Vissim Template can be requested from NP

representation of vehicles' behaviour and interactions. The list below gives some examples where it is necessary to develop Vissim models in order to meet the purpose of a modelling project:

- Where over-saturated conditions exist, and particularly where exit-blocking occurs, or where queues interact with other facilities;
- Where network infrastructure changes dynamically throughout the modelled period (such as VA signal control, demand dependency, bus priority at signals);
- To model UTC-specific dynamic signal timing strategies (for example SCOOT, SASS, gating) through use of the UTC-Vissim Interface (section **B7.4.5.3**);
- Where detailed cyclist behaviour (Chapter **C2** on **Cyclist Modelling**) or pedestrian behaviour (Chapter **C3** on **Pedestrian Modelling**) is required;
- Where accurate journey time prediction is important as an improvement measure (for example a bus priority scheme); and
- Where it is necessary to visually demonstrate the operation of a scheme, traffic management technique or control strategy for use in a stakeholder consultation or Public Inquiry.

7.2 Preparation

General guidance on Base model development is provided in [B2.4](#). This section provides specific guidance for building Base models using Vissim. Model preparation should be discussed at the scoping meeting (section [B2.1.5.1](#)) and decisions documented within the Modelling Expectations Document (MED, section [B2.1.5.2](#)).

7.2.1 Model Boundary

Vissim is able to model adjacent CLF or UTC groups operating different cycle times. It can therefore assess the impact of scheme proposals which cover two or more traffic control groups. Where blocking back from one group impacts traffic upstream, Vissim can be used to predict the magnitude and frequency of any operational issues and test proposals for mitigation. For this reason, where possible, junctions which generate significant queuing in the area of interest should be included in the modelled area. If it is not possible, for example if the cause of queuing would significantly increase the size or complexity of the model, then a proxy must be used. See section [B7.4.2.6](#) for more details.

When deciding on the Vissim model boundary, the length of external links (such as those where vehicles are loaded onto the network) should be considered.

An external link ought to be long enough to contain all traffic expected to enter within the modelled time period in all scenarios.

There are two reasons this should be done:

- To ensure that any upstream blocking back effects can be easily identified (visually) and mitigated; and
- To ensure that when measuring scheme performance parameters (examples include; journey time, delay, queue length, average speed) all vehicles are included. If some vehicles are not successfully loaded into the network, the model will produce a biased result which may underestimate the capacity impacts of the scheme.

If the Links are not long enough then vehicles will queue outside of the modelled area waiting for a space to enter. All Links should be extended to capture the extent of the queuing.

7.2.2 Data Collection

Prior to building a model in Vissim the following information should already have been obtained, as identified in sections **B2.2** and **B2.3**:

- Background images (section **B7.2.4**);
- Familiarity with site operation and driver behaviour;
- Traffic flows and turning proportions;
- Traffic flow compositions (according to vehicle classifications);
- Bus frequencies;
- Bus stop locations;
- Bus stop dwell times;
- Signal timings and controller logic;
- Saturation flows;
- Vehicle journey times;
- Queue lengths;
- Mandatory speed limits; and
- Parking and loading.

The following data may also be needed, depending on the purpose of the model:

- Origin-Destination (OD) surveys;
- Speed and acceleration profiles;
- Bus boarding and alighting surveys;
- Pedestrian flows; and
- Bus occupancy surveys.

In addition to collecting the above data, skeleton deterministic models should be produced for all junctions to be modelled in Vissim, as detailed in section **B4.1.3.2**. This will ensure signal timings are accurately represented, particularly when modelling stage and interstage relationships.

The remainder of this section provides specific guidance on the collection of some of the above data as necessary for the preparation of Vissim models.

7.2.2.1 Site Observation

Microsimulation models are able to simulate complex interactions between road users and their environment.

It is therefore essential that observations are undertaken at sites being modelled so that interactions can be noted and replicated in the model. It is not sufficient to use drawings and aerial photography only to build a model, as these are static sources and may not convey all the dynamic aspects of the site.

CCTV may also be used; however, this is not an ideal solution as not all areas are covered and it is easy to pay less attention to areas which cannot be seen. Preferably, CCTV would be used in addition to, rather than instead of, site visits.

Examples of behaviours which should be observed are:

- **Space utilisation** – particularly where usage does not match lane markings;
- **Blocking back** – through junctions, across crossings, yellow boxes and keep clears, anywhere another traffic movement is prevented from continuing on its desired path;
- **Lane changing** – particularly the decision point where vehicles decide to change lanes for turns;
- **Parking** – both legal and illegal if it is persistent and takes space away from moving traffic;
- **Queuing** – locations, lengths, and behaviour; and
- **Gap acceptance** – at give-ways or opposed right turns.

These can significantly affect model results and must be understood from site visits in order that they can be accurately replicated in the model.

It is also important, whenever possible, to carry out site observations on days when traffic surveys, for example counts or journey times, are taking place. As described in section [B7.5.1](#), it is important to verify that the data collected represents a day that is considered typical or the data collection may need to be repeated at a later date.

7.2.2.2 Signal Timings

Guidance on how to collect and use signal timing data is provided in **B2.3.8**. As described in section **B7.4.5**, the two main methods for controlling signals used at TfL are VAP and UTC-Vissim. Where VAP is used to control signal timings, the data requirements include phase, stage and intergreen data from Timing Sheets. For UTC junctions the control plan is also needed, along with the frequency of any demand-dependent stages. MOVA sites record log files containing signal timings. These are stored for a limited time and must be downloaded from the controller so TfL must be consulted if this is required. Alternatively, for VA or MOVA junctions green time surveys can be used to determine the average frequency and duration of each stage.

If more complex forms of dynamic control, such as bus priority, have a significant impact on the behaviour of the junction, then information on this should be collected so that it can be replicated appropriately. Alternatively, it may be preferable to use the UTC-Vissim Interface, a software interface between Vissim and a copy of TfL's UTC system. The interface allows TfL engineers to simulate the real behaviour of the UTC system and associated applications including SCOOT, SASS and bus priority. If this method is being used it is necessary to verify that the data included in the UTC cell is from the appropriate date for the model. See section **B7.4.5.3** for further information on UTC-Vissim.

7.2.2.3 Saturation Flows

In most cases, a Vissim model will be developed to complement an existing validated LinSig or TRANSYT model which already contains measured saturation flows, so saturation flows from those accompanying models should be used for calibration of the Vissim model. Guidance on saturation flow measurement is provided in **B2.3.9**. Where a validated LinSig or TRANSYT model is not available, it will be necessary to measure saturation flows for the purposes of calibrating the Vissim model. These are some examples of situations where it is critical to measure saturation flows for a Vissim model:

- Approach has extensive queues, for example a bottleneck;
- Approach is an entry into the Vissim network;
- There are proposed changes to the layout; and
- There are proposed changes to the method of control or intergreens.

This is not an exhaustive list and it remains necessary to exercise good judgement when assessing situations where it is critical to measure saturation flow.

7.2.2.4 Journey Times

It is necessary to have journey time data to validate a Vissim Base model. In recent years, sources of automated survey data have become available which give a much wider range of possibilities when it comes to choosing dates, times and distances. In particular, it is possible to get an average journey time over multiple days, which provides a more robust value to validate against. The sources of data include Automatic Number Plate Recognition (ANPR) cameras and aggregated records from sat-nav companies. It is also possible, if required, to commission video surveys of an area or use CCTV to manually match vehicles along a particular stretch of road. Where it is not possible to source other forms of data, journey times should be collected using the 'floating car' technique (section **B2.3.4.3**).

Journey time data should be collected at the same time as the other traffic surveys if possible, however for larger networks it may be necessary to conduct the surveys over several days. Journey times in Vissim can be collected and measured over any length of any route making it adaptable to available site-measured journey time data. It is recommended that journey time data is collected over smaller distances in addition to the full routes, as this will help with locating any disparities during validation.

7.2.2.5 Public Transport

Bus data in London is recorded using the iBus system, which collects data on frequencies, journey times and dwell times for each bus. There is a standard data format that is used for microsimulation models which aggregates by the hour, however, if the modelling requires more granularity then this is also possible. This data can be requested from TfL but any requests must go through a TfL sponsor to ensure the request is valid and formatted correctly.

Information on the running of coach lines should be sourced from the relevant company's website.

7.2.3 Model Time Periods

The model time period should be specified to match the requirements of the analysis to be undertaken and based on the flow data which has been collected. In addition, a warm-up period to pre-load the network with traffic and generate queues prior to the study period should be included. General guidance on model time periods is given in section **B2.3.3**.

Vissim is not constrained to modelling a single peak hour period. For a broader assessment it is possible to create models which cover three or more hours, which is beneficial for an assessment of traffic during the shoulders of a peak period or where models are sufficiently large that different areas of the model experience localised peaks at different times.

Vissim models must include a warm-up period in addition to the evaluation period. The extent of the warm-up period will depend on the network size and congestion level. The warm-up period should be at least as long as a typical journey through the network but in most cases a 15 to 30-minute warm-up is sufficient. Therefore, Vissim models with a single hour of analysis will cover 1.25 hours as a minimum. A cool-down period may also be included if there is the possibility that the proposal could extend the peak hour(s).

7.2.4 Background Images

The primary source of background data for the areas surrounding junctions should be Site Layout Drawings (SLDs) as these contain detailed information on the location of traffic infrastructure. Aerial photographs and detailed topographical drawings may be used to supplement SLDs, but they should not be used in isolation for building the traffic network.

Background drawings on which the traffic network is built should be of sufficient detail and accuracy to give information on relevant network elements such as signal stoplines, give-ways, bus stop locations and lane marking arrangements.

Before the network build begins, it is essential that the background is scaled correctly. This should automatically be the case when loading SLDs which have been saved in Model view, but it should always be checked. As an additional safeguard it is suggested that a scale marker is included on the background which should be at least 100m in length.

Vissim uses a generic Cartesian coordinate system rather than any particular map projection. At TfL the British National Grid (BNG) coordinate system is used for SLDs and any Vissim modelling, and therefore its background imagery, should also use this system. Although Vissim has the capability to load online mapping from sites such as Bing and Open Street

Map, this is not recommended as it will not match the BNG coordinates and also the imagery changes over time so the references used to calibrate the Vissim network may be lost.

Finally, as described in **B2.3.1** and **B2.3.2**, it cannot be assumed that drawings and aerial photographs are up to date and accurate. Therefore, it is necessary to check layout details during site visits to confirm their accuracy.

7.3 Graphical User Interface

While the traffic model in Vissim has remained broadly similar between different versions, as indicated above, there was a significant change in the interface after version 5.40. This section gives a brief introduction to some of the newer features.

The main theme behind these features is user configurability, so each interface element comes in its own window which the user can place wherever they like on the screen. It is possible to control viewing and editing of network elements separately, so all network elements can be viewed at the same time, which is useful when it comes to looking at the relative positioning between elements.

7.3.1 Network Objects

The Network Objects window (**Figure 116**) determines which objects are displayed (in the left-most column), whether they can be selected (second column), whether the label is displayed (second from right) and how they are displayed (right-most column). It also highlights the type of object which can currently be created. Right-clicking on an entry is the easiest way of accessing the List (section **B7.3.2**) for that object type and can also be used to change the way the object and its label are displayed via the Edit Graphic Parameters option.

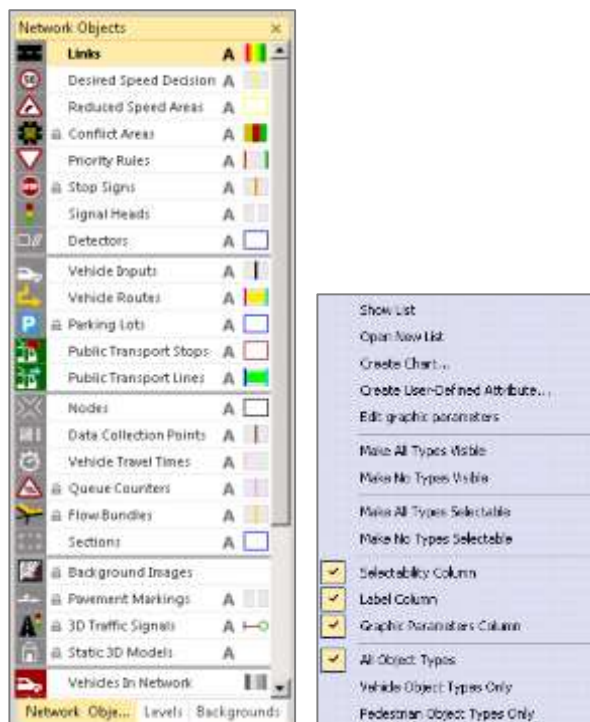

Figure 116: Network Objects window and a typical right-click menu

7.3.2 Lists

The key feature of later versions of Vissim is the List window. This is similar to the window which appeared on right-clicking the background in earlier versions of Vissim, except the contents of the List is user-customisable and editable, and it is possible to display the Lists of multiple objects or datasets at the same time. Multiple cells can be edited to the same value at the same time by selecting them together.

It is possible to display two linked lists together. One useful example is Links / Static Vehicle Routes, which shows, on the right, the Routes which use whichever Link is selected on the left (**Figure I 17**).

Figure I 17: Linked Lists with Links on the left and Static Vehicle Routes on the right

Another example is Public Transport Lines / Public Transport Line Stops, which shows all the stops a bus route travels through and whether they are active or not. In **Figure I 18** below, a column showing the Dwell Time Distribution for each stop has been added through the Attribute Selection button.

Figure I 18: Linked Lists with Public Transport Lines on the left and Public Transport Line Stops on the right

User Defined Attributes (UDAs) can also be added to the Lists. These can consist of data from external sources (such as validation data) or formulae using data already in the model. Finally, Lists also display results data so outputs can be viewed inside Vissim. **Figure I 19** below shows an example

of Node results, and further information can be found in section **B7.7**.

Queue	Signal	Stopline	Movement	Queue	Signal	Stopline	Movement	Queue	Signal	Stopline	Movement	Queue	Signal	Stopline	Movement	Queue	Signal	Stopline	Movement
1.1	1806-5420	124	2000@12.8 - 1806@5.0	0.00	39.85	508	400	50	0	11	4.44	4.70	1.60	0.18	175.300	34.221	45.750		
2.1	1806-5420	124	2000@52.7 - 2000@62.1	0.00	17.20	1415	2066	49	47	229	0.11	0.11	0.00	0.00	41.034	8.130	8.605	250.32	
2.1	1806-5420	124		0.41	39.85	2000	2059	90	52	230	1.83	1.83	0.48	0.01	218.201	42.454	50.370		
4.1	1806-5420	125	2000@11.9 - 2000@6.7	0.20	49.81	428	348	40	2	30	1.05	1.13	0.48	0.01	25.750	5.010	5.369	250.32	
5.1	1806-5420	125	2000@19.0 - 2000@7.2	9.04	95.42	1101	705	30	49	211	7.60	7.41	4.57	0.22	175.418	53.825	63.876	127	
6.1	1806-5420	125		4.71	95.42	1727	1113	30	47	222	0.63	0.70	3.42	0.18	304.397	59.217	70.530		
7.1	1806-5420	126	2000@14.8 - 2000@18.8	0.00	0.20	468	389	42	1	11	0.53	0.54	0.00	0.00	19.087	3.708	4.417	240.11	
8.1	1806-5420	126	2000@14.8 - 2000@18.8	17.19	178.85	618	496	40	42	196	23.47	23.21	34.98	0.58	588.424	110.799	131.070	128	
8.1	1806-5420	126		0.60	178.85	1279	886	40	43	207	14.39	14.02	9.88	0.58	606.865	118.637	139.816		
12.1	1806-5420	127	2000@42.3 - 2000@49.8	0.30	43.22	427	349	40	2	30	14.30	15.11	60.98	0.48	188.828	38.152	41.800	128	
13.1	1806-5420	127	2000@12.2 - 2000@18.6	0.43	48.20	1195	706	31	43	215	0.61	0.68	0.00	0.00	44.113	8.503	10.224	240.11	
12.1	1806-5420	127		3.50	48.20	1312	1117	31	46	228	4.68	4.68	3.11	0.12	217.358	42.329	50.421		
12.1	1806-5420	128	2 - New Green Road@180.2 - 0 km	0.15	38.42	472	392	41	1	12	3.77	3.92	0.02	0.00	126.368	23.418	27.895	128	
14.1	1806-5420	129	7@4.1 - 7@12.6	0.02	6.12	816	502	49	42	194	0.42	0.38	0.03	0.08	52.190	15.156	12.897	240.11	
15.1	1806-5420	129		0.00	31.42	1389	894	30	43	206	3.64	3.67	0.02	0.00	175.009	36.866	43.971		

Figure I 19: Node Results List

Since the Lists can be sorted by any of the columns in either of the linked Lists, the List view can be used to edit the display properties so that, for example, Links and Lanes with the same characteristics can quickly and easily be given the same colour. In **Figure 120**, stopline Links have one behaviour (dark green), there is a merging behaviour on the exit to the junction (light green), and Lanes which are closed to particular Vehicle Classes are highlighted (red).

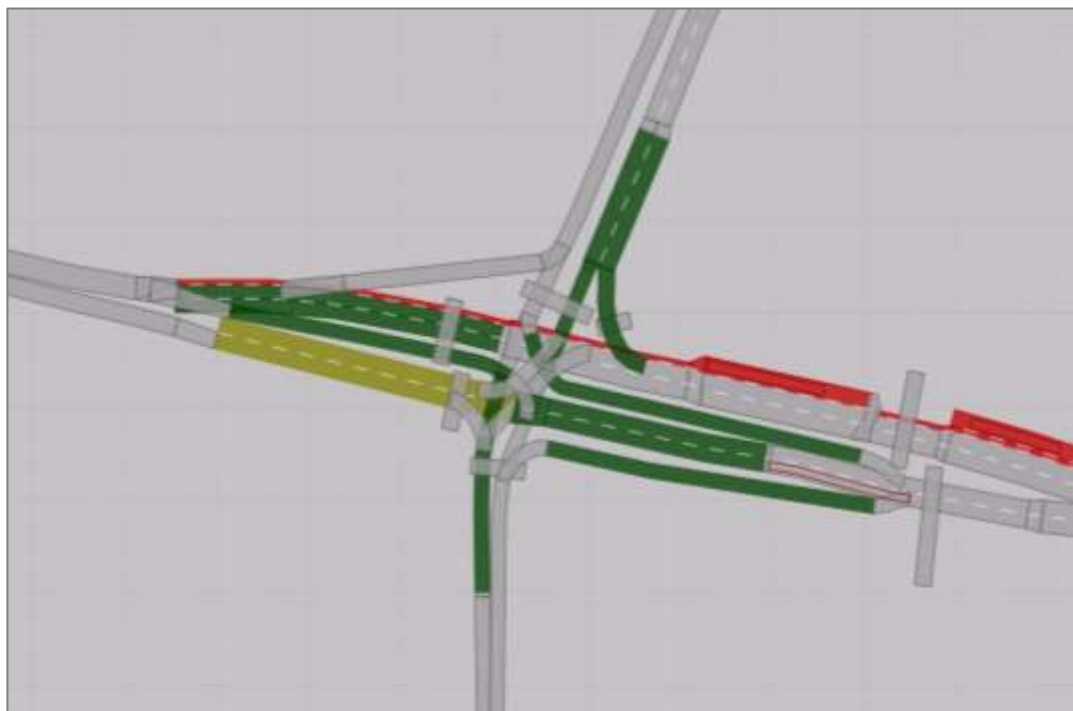
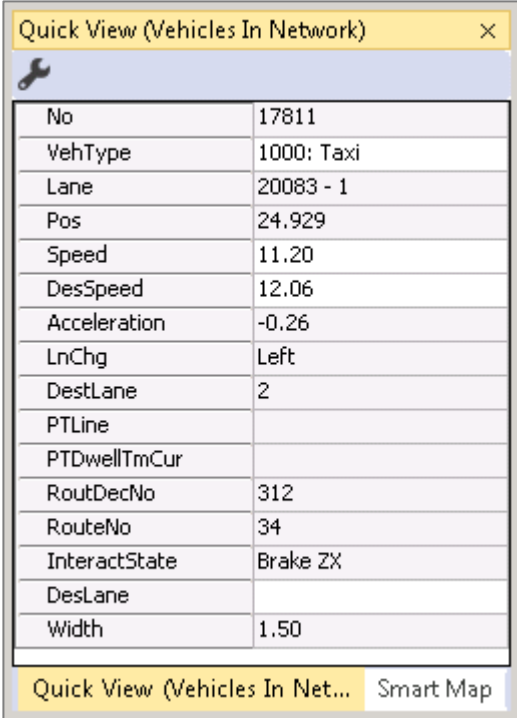

Figure I 20: Screenshot showing Link characteristics in different colours

7.3.3 Quick View

The content of the Quick View window is dependent on the network element which is selected. Each element type has a user-configurable selection of data, including UDAs, which can be displayed and also edited in the window.

Quick View is a useful tool during calibration for interrogating the model and working out why vehicles are displaying a particular behaviour (**Figure 121**). It is configurable to show a large variety of data about any vehicle which is clicked on during a simulation run, and can therefore be used to find out the interactions which are currently acting on the vehicle.



The screenshot shows a window titled "Quick View (Vehicles In Network)" with a close button (X) in the top right corner. Below the title bar is a toolbar with a wrench icon. The main area contains a table with two columns: a property name and its corresponding value. At the bottom of the window, there are two buttons: "Quick View (Vehicles In Net..." and "Smart Map".

No	17811
VehType	1000: Taxi
Lane	20083 - 1
Pos	24.929
Speed	11.20
DesSpeed	12.06
Acceleration	-0.26
LnChg	Left
DestLane	2
PTLine	
PTDwellTmCur	
RoutDecNo	312
RouteNo	34
InteractState	Brake ZX
DesLane	
Width	1.50

Figure 121: Quick View (Vehicles In Network) window

7.3.4 Scenario Management

Scenario Management enables multiple scenarios to be assessed within a single input file (*.inpx). Operating multiple scenarios in the same file provides some benefits to the development of models, however, when it comes to submission to TfL for auditing, it is recommended that each scenario should be submitted as a single input file (*.inpx). One reason for this is the potential problems which may be caused by different external signal control files applying to different scenarios, particularly when UTC-Vissim is in use, as is explained in section **B7.6.2**. A scenario can be exported via File > Scenario Management > Project Structure, Scenarios tab, then selecting the relevant scenario and clicking the Export Selected Scenarios button, as shown in **Figure 122**. Further information on Scenario Management can be found in section **B7.6.2**.

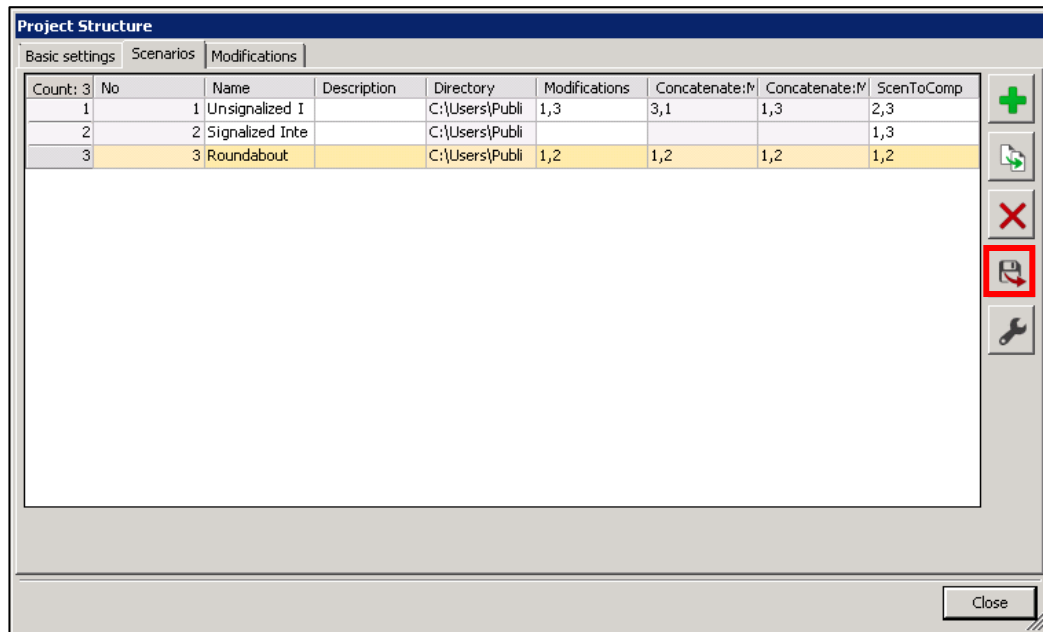

Figure 122: Project Structure window

7.4 Base Model Calibration

Once the input data has been collected, it can be used to build and calibrate the model. This section provides guidance on the structure of data in Vissim and how to approach the model build.

A calibrated Vissim model should have as a minimum:

- Correct fundamental parameters and units;
- The correct, appropriate link structure which replicates traffic behaviour on street;
- Reduced speed areas placed at appropriate places in the network, and used as a mechanism to calibrate saturation flows;
- Accurately modelled priority rules / conflict areas that result in correct reflection of existing on-street conditions in the model;
- Appropriate and correct traffic flow and routing using data from on-street surveys, in accordance with the scope and purpose of the model;
- Correct public transport data collected from reliable sources and modelled accurately. The level of detail of public transport modelling is dependent on the purpose of the model; and
- All the correct on-street signal control data with representative signal timings for the network during the period under consideration.

A key part of building a properly calibrated and validated Vissim model is observing the model while it is running. Accurate representation of vehicle behaviour is necessary for the model to fulfil its purpose. The animation features of Vissim can be used during calibration to identify irregularities in driver behaviour that may adversely affect model operation.

The model should be observed during multiple seeds to gain a rounded picture of its performance and provide reassurance that all the network elements are functioning correctly.

7.4.1 Model Parameters

There are certain parameters which should be agreed and set at the start of model development. Changing these parameters after calibration will invalidate model results.

The Vissim Simulation Parameters dialogue for an example model is shown in **Figure 123**.

Simulation parameters

General Meso

Comment: Example Model

Period: 5400 Simulation seconds

Start time: 07:30:00 [hh:mm:ss]

Start date: 20190601 [DD.MM.YYYY]

Simulation resolution: 5 Time step(s) / Sim. sec.

Random Seed: 42

Number of runs: 1

Random seed increment: 1

Dynamic assignment volume increment: 0.00 %

Simulation speed: 10.0 Sim. sec. / s
 Maximum
 Retrospective synchronization

Break at: 0 Simulation seconds

Number of cores: use all cores

OK Cancel

Figure 123: Simulation Parameters window

7.4.1.1 Start Time and Date

For most models the Start Time and Start Date parameters are useful to indicate the modelled time and date. For UTC-Vissim models, however, this data is essential as it tells the UTC cell what time the model is representing so UTC can load the correct signal timings using its internal timetable. Further information on UTC-Vissim can be found in section **B7.4.5.3**.

7.4.1.2 Simulation Resolution

Simulation Resolution is the number of time steps, or how often vehicles are moved and their positions recalculated, in a simulation second. This should be set to 5 steps per simulation second (resulting in 0.2 seconds per step), unless autonomous vehicles are being modelled, in which case consideration should be given to higher values as machines can react more quickly than humans. The Simulation Resolution must be chosen before calibration. The Simulation Resolution cannot be changed later without the need for model re-validation as driver behaviour, and therefore model results, will be changed.

This parameter should not be used to increase the speed of the simulation. Whilst reducing this value does result in faster simulation run times there is an impact on model accuracy. Instead, simulation run times can be reduced by removing the animation of vehicles, or by reducing the animation refresh interval.

7.4.1.3 Random Seed

The use of random seed values for model validation is explained fully in section **B7.5.1**, however it should be noted that during calibration, when observing the model running, it is good practice to change the seed regularly in order to avoid overfitting the model to one particular set of conditions. Changing the seed value may also reveal issues which are not present in every run.

7.4.1.4 Units

The following settings are recommended for units (Base Data > Network Settings... > Units), as shown in **Figure 124**:

- Distance: Set to m and km;
- Speed: Set to mph and m/s; and
- Acceleration: Set to m/s².

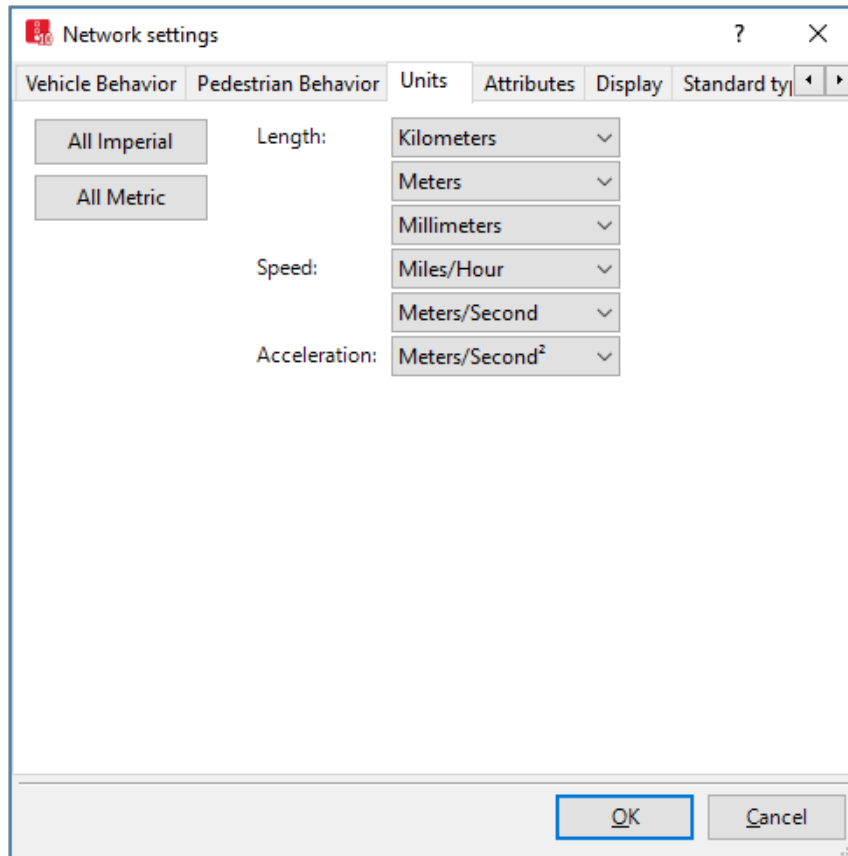

Figure 124: Network Settings window

7.4.1.5 Traffic Regulations

Traffic should be set to drive on the left (Base Data > Network Settings... > Vehicle Behavior) as this will impact any overtaking or multi-lane link behaviour.

7.4.2 Network

Any traffic model includes a representation of the road network with various rules to control the vehicles moving on it. This section contains information on how the Links and Connectors, and objects such as Reduced Speed Areas and Priority Rules, should be placed to generate realistic traffic movements.

7.4.2.1 Links and Connectors

The Vissim network structure is built using Links and Connectors. As a general rule, the number of Links and Connectors should be minimised and Connectors should be kept short. Where Connectors join to Links, overlapping should be avoided as this creates unrealistic capacity if vehicles can use both the Connector and continuing Link. Care should also be taken that Connectors starting at the end of Links start as close to the end of the Link as possible. This avoids the situation where network objects (such as Signal Heads, Priority Rules, Data Collection Points) are accidentally placed after the Connector leaves the Link. An object on a Link is ignored by a vehicle which has already left that Link across a Connector which started upstream of the object. It is advisable to check, after any network editing, that vehicles still travel over all the network objects that they need to.

All turning manoeuvres should occur across connectors, including all movements through the interior of junctions, as connectors allow lane discipline and queuing behaviour to be enforced using the lane change and emergency stop distance parameters.

When modelling lane gain (for example a flare) or loss, a single Connector should be used rather than multiple lane-to-lane Connectors, and the Link extended as necessary to allow diverging and merging at the correct location, as illustrated in **Figure 125**. If necessary, more Connectors can be added to enforce observed behaviour. However the starting point should be that shown in **Figure 125** to enable Vissim to control the vehicle interactions, particularly on merges. Advanced merging should be enabled in the driving behaviours in order for this to operate correctly. Where rigid queuing behaviour is observed on street, normally due to local knowledge and often observed at right-turns, Links can be split to model each lane separately to allow explicit routing along that Link. Alternatively, short Connectors can be placed within the lane (meaning they connect a Link with itself) allowing routing paths to be specified across those connectors. This is a last resort solution which rigidly enforces queuing behaviour. If using Dynamic Assignment (section **B7.4.4.2**), parallel Links or Connectors should be avoided because this leads to additional paths and unnecessary

additional lane changing, making convergence more difficult.

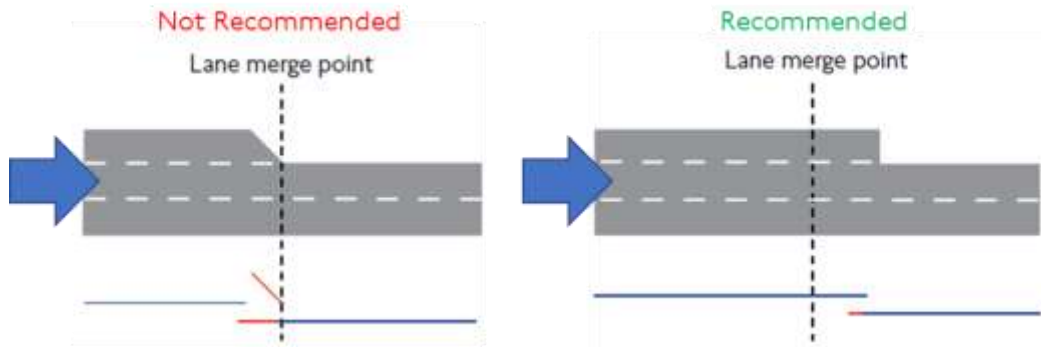

Figure 125: Lane merge layout options with the recommended layout on the right

The merge point can be influenced using the Lane Change distance option, available in the Connector attributes dialog. The Lane Change distance value is used to govern the movements of vehicles that follow a Route, or, in Dynamic Assignment, a Path. It is the distance before the Connector those vehicles whose Route or Path leads across this Connector start trying to change lanes to reach it.

On highways this value needs to be increased and the use of the Per Lane option is recommended for Links with more than two lanes. In later versions of Vissim, the Lane Change distance can also be specified as a distance distribution which makes it possible to spread out the start positions of lane changes over a longer area. It can also be defined by Vehicle Class so that, for example, vehicles with good route knowledge could change lanes earlier.

Bus lanes can be modelled as part of a multi-lane Link using lane closures. This is preferable to modelling bus lanes as a separate link, which forces taxis and powered two-wheelers to choose between using bus or general traffic lanes and doesn't allow buses to overtake stationary buses by using an adjacent general traffic lane. This approach also allows the same Link / Connector structure to be used for time periods where the bus lane is not in operation. If a bus lane is not modelled as a separate link then separate connectors are recommended for the general traffic and bus lanes, with connectors closed to specific vehicle classes to reduce Dynamic Assignment Paths. This allows vehicles to be routed into the correct lanes in advance to avoid vehicles entering bus lanes during congested periods.

7.4.2.2 Link Driving Behaviour

It is recommended that default Driving Behaviours should be used during the Base model build. Adding new Driving Behaviours at this early stage

complicates the model development process. Further Driving Behaviours can be defined later, during the calibration stage, as necessary. The number of additional Driving Behaviours used should be kept to a minimum.

Additional behaviours should be discussed with MAE prior to being added to the model.

Driving Behaviours are assigned to Links via Link Behaviour Types. Link Behaviour Types consist of a default Driving Behaviour together a list of exceptions linking Vehicle Classes with associated Driving Behaviours.

For London urban networks the Wiedemann 74 model⁹⁷ should be used and the model build started using the default Urban (motorised) behaviour which is assigned to the default Urban (motorised) Link Behaviour Type. However, it is recommended that the following parameters be changed in the default Urban (motorised) behaviour:

- Links that allow lateral behaviour should increase the value of Min. Look Ahead Distance from 0 to 30m (at 30mph speed limits). This will ensure that vehicles see each other and obey traffic signals when vehicles can queue next to each other in the same lane;
- Amend the Average Standstill Distance to 1.2m for all link types; and
- All Driving Behaviours used on Links approaching signal-controlled intersections should adjust the Driving Behaviour parameter Behaviour at Red / Amber Signal to the value Stop (same as red). This prevents vehicle discharge during the red / amber period.

It is advised that all other Driving Behaviour parameters are left at their default values unless supported by site observation and measurement. Care should be taken when adjusting default Driving Behaviours, as a parameter change will affect all the Links with which that Behaviour is associated.

It may sometimes be necessary to apply modified Driving Behaviours where drivers behave more aggressively, such as at specific junctions or where more forceful merging is required. Similarly, if modelling cyclists, additional behaviour types may be needed at bus stops or on the approach to traffic signals (see Chapter **C2** on **Cyclist Modelling**). Should default values need to be modified, any changes should be minimal, confined to specific locations / link behaviour sets and documented for assessment through MAP.

In later versions of Vissim, a Reaction Time Distribution has been introduced. If the reaction time to the green light is considered important in a particular project then data should be collected to inform the

97 Wiedemann R, *Simulation des Straßenverkehrsflusses*, Schriftenreihe des IfV, 8, Institut für Verkehrswesen, Universität Karlsruhe, 1974 (in German)

distribution used, and should be included in the validation report. Otherwise it should be left blank, which assumes a reaction time of 0 seconds (Figure 126).

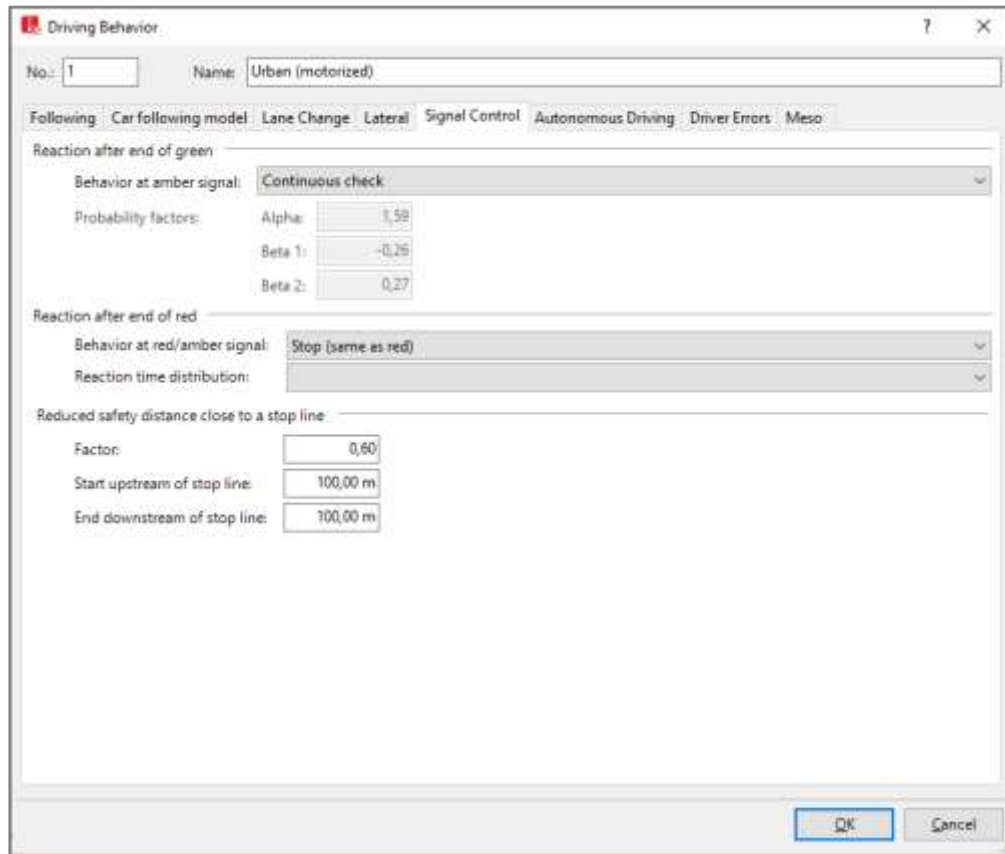

Figure 126: Driving Behaviour window

7.4.2.3 Reduced Speed Areas and Desired Speed Decisions

Reduced Speed Areas (RSAs) are required wherever on-street road geometry causes drivers to decelerate (for example at bends, corners, humps or poor visibility). For turning manoeuvres, it is advised that a set of speed distributions are created, each one applying to a certain range of turn radii, with smaller radii using slower speed distributions. Larger vehicles, including buses and HGVs, should have their own set of speed distributions. This aids calibration, as changing a specific speed distribution will affect all turning movements of a particular radius for that vehicle type.

Vehicles will automatically decelerate before entering an area and speed up again after leaving the reduced speed area or after travelling for a distance equal to the length of the RSA, whichever is longer. If the RSA is

coded with a speed distribution faster than a particular vehicle's class-specific speed, the vehicle will not accelerate to this speed distribution before reaching the RSA. Once within the RSA, the vehicle is assigned the higher speed decision distribution. Once leaving, the original speed decision is reassigned to the vehicle.

It is strongly recommended that RSAs are not used for the creation of artificial queues. Queues form for many reasons, for example exit-blocking, parking and merging behaviour, and these should form in the model as on street. If these features are not included within the model boundary then RSAs could be used as a proxy to slow vehicles down (section **B7.4.2.6**). They can be used, however, to model the effect of physical speed restrictions, such as width restriction bollards or speed bumps.

Desired Speed Decisions (DSDs) are normally used where vehicles move between one mandatory speed limit and another, for instance where entering or leaving a motorway. They are also the best method for controlling speeds used in gyratory networks, with DSDs placed across all entries and exits. The vehicle will not change speed – either accelerating or decelerating – until after it has crossed the DSD. This will ensure circulatory speeds are appropriate and all vehicles return to normal speeds on exiting. RSAs should be used sparingly within gyratory links, as any vehicles crossing the start of the RSA will travel at the specified speed for a distance equal to the whole length of the RSA, whether they are still in the RSA or not. DSDs should also be used in preference to unduly long RSAs.

7.4.2.4 Saturation Flows

For models with closely spaced signal-controlled junctions, as is the case in much of London, it is important to get the rate of discharge correct across the major stoplines. There is no way to enter a value for saturation flow directly into Vissim. Instead, the resulting saturation flow is influenced by other input parameters. The two main factors that influence saturation flow are the speed of the vehicles and the distance between them. The distance between vehicles is dictated by Driving Behaviours (the parameters of Wiedemann 74 that influence saturation flow are the Average Standstill Distance, Additive Part of Safety Distance and Multiplicative Part of Safety Distance), however, the standard Driving Behaviour parameters in Vissim typically produce models which appear to run too freely at stoplines. For example, using standard Driving Behaviours and the 20mph Desired Speed Distribution⁹⁸ from the TfL Vissim Template

98 Transport Statistic Bulletin: Vehicle Speeds in Great Britain 2005, Department for Transport, 2006

(section **B7.1.2**) provides an indicative saturation flow of 1900 – 2100 in free flow traffic. Creating excess numbers of Driving Behaviours is not recommended (section **B7.4.2.2**), so the preferred approach is to use RSAs to calibrate the saturation flow.

It is recommended that RSAs are used at all stoplines to calibrate junction approach saturation flows. These RSAs should extend both upstream and slightly downstream of the signal stopline and be 10 - 15m in length, as shown in **Figure 127**.

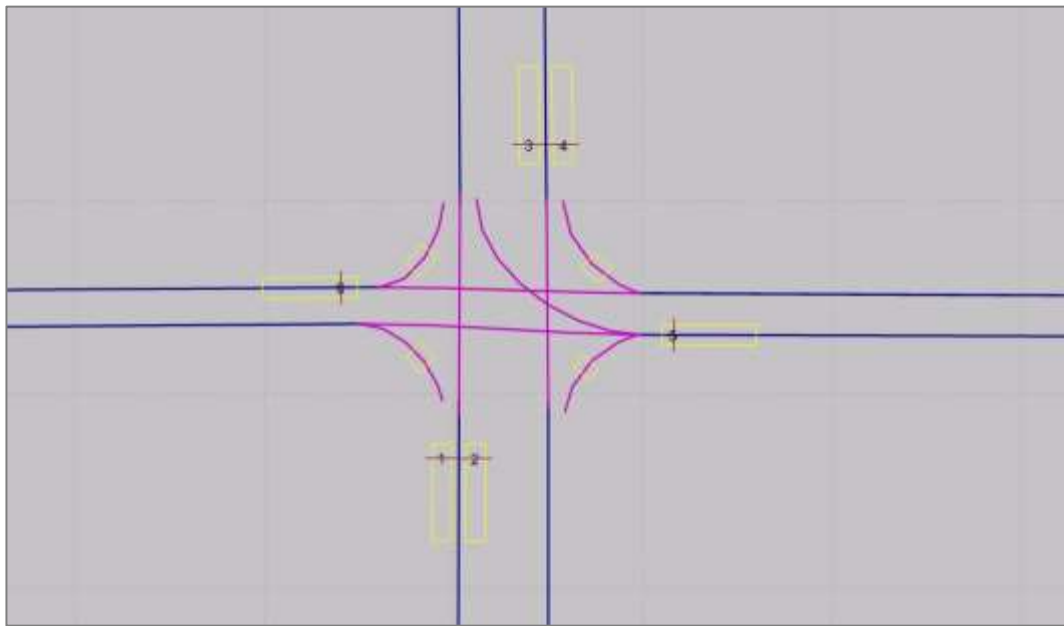

Figure 127: Placement of RSAs for saturation flow calibration

The stopline saturation flows should be calibrated by systematically changing the RSAs and comparing the model against observed saturation flows. M&V can provide a spreadsheet to compile Vissim output information and aid collation of saturation flow data.

7.4.2.5 Priority Rules and Conflict Areas

Priority Rules and Conflict Areas are the two options Vissim has available to control movements within signalised junctions, such as opposed right turns, and at all unsignalised junctions. A model can use either priority rules or conflict areas or a combination, however, given the congested nature, density and spatial constraints of London's road network, TfL recommends the use of Priority Rules in most situations. This is because they are individually placed within the road network, which gives them more flexibility to replicate observed conditions. Conflict Areas can be more beneficial for pedestrian crossings as they are quick to insert and the stopping locations are well defined.

There are a number of useful examples of both types in the Vissim User Manual⁹⁹.

7.4.2.5.1 Priority Rules

Priority Rules can have a significant impact on vehicle journey times, queues and congestion when used in networks containing give-way junctions and unsignalised roundabouts. Multiple Priority Rules may be necessary for a single movement through a junction, and Priority Rules can also be set up separately for individual Vehicle Classes. Priority Rule calibration is one of the most difficult aspects of model development as model outputs can be extremely sensitive to Priority Rule settings. It is therefore vital to have sufficient experience in use of Priority Rules to correctly replicate on-street behaviour.

The default parameters are usually suitable for simple priority movements at junctions, although their behaviour should still be checked. A typical consideration is to look at the location of Conflict Markers in relation to the ends of Connectors. If the Conflict Marker is downstream from the Connector then the Headway and Gap Time parameters will look along both possible routes, which may not be the intended behaviour (**Figure 128**).

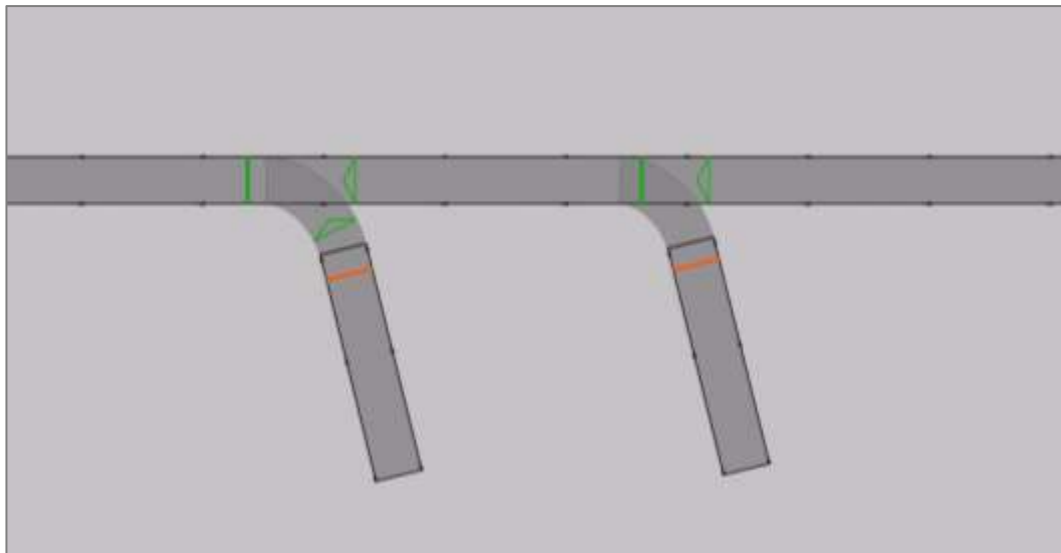

Figure 128: Priority Rule configurations showing the effect of different placements of the Conflict Marker

Some examples of more complex Priority Rule usage are shown below:

It may sometimes be necessary to place Conflict Markers with Gap Time and Headway parameters set separately, with the other parameter set to

zero, where on-street conditions cause the conflicts at different speeds to happen in different places. Typically, the Headway marker would be downstream of the Gap Time marker as this allows vehicles at the Stop Line marker to move off more quickly when the traffic they are waiting for is moving faster. If this technique is used, then the Headway marker should have its Max Speed limited so it only recognises slow-moving vehicles, as illustrated in **Figure 129**.

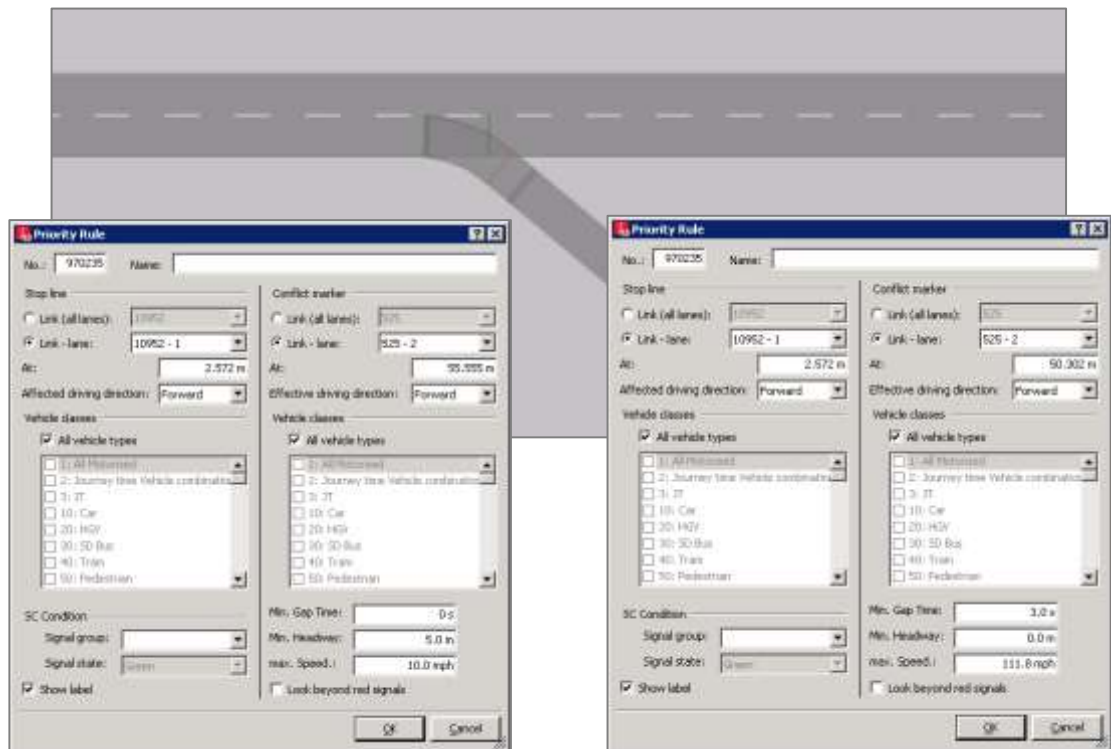
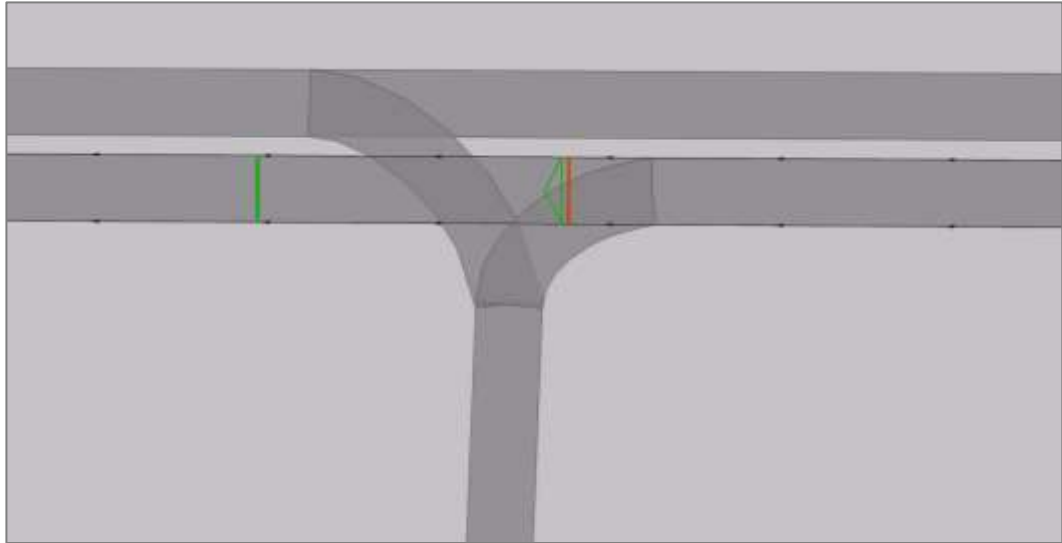

Figure 129: Configuration of Priority Rules to account for Headway and Gap Time separately

At a yellow box or keep clear (**Figure 130**), key points to remember are:

- The Conflict Marker should be placed so that there is space for one vehicle between it and the location of the conflict. Depending on behaviour, this may make it necessary to have a separate Priority Rule for longer vehicles;
- Check the Vehicle Classes for both the Stop Line and Conflict Marker – cyclists should not be included;
- The Min. Gap Time should be zero;
- The Min. Headway should cover the distance from the Conflict Marker to the Stop Line; and
- The Max. Speed should be low enough that free-flowing traffic ignores the Priority Rule, this is dependent on the location, but 8-10mph is a good starting point.



Priority Rule [?] [X]

No.: 970234 Name: _____

Stop line

Link (all lanes): 10951

Link - lane: 10951 - 1

At: 56.279 m

Affected driving direction: Forward

Vehicle classes

All vehicle types

1: All Motorised

2: Journey time Vehicle combination

3: JT

10: Car

20: HGV

30: SD Bus

40: Tram

50: Pedestrian

SC Condition

Signal group: _____

Signal state: Green

Show label

Conflict marker

Link (all lanes): 10951

Link - lane: 10951 - 1

At: 72.653 m

Effective driving direction: Forward

Vehicle classes

All vehicle types

1: All Motorised

2: Journey time Vehicle combination

3: JT

10: Car

20: HGV

30: SD Bus

40: Tram

50: Pedestrian

Min. Gap Time: 0 s

Min. Headway: 16.0 m

max. Speed.: 8.0 mph

Look beyond red signals

OK Cancel

Figure 130: Example of a ‘yellow box’ Priority Rule setup

It is necessary to observe the behaviour of vehicles under a variety of different traffic conditions to verify that the Priority Rules perform as expected and do not produce unrealistic behaviour in any scenario.

7.4.2.5.2 Conflict Areas

Conflict Areas are an alternative method for controlling vehicle interactions at junctions. The list below contains a few basic features, but the key point is that parameters should be set up so that vehicles behave as they do on street.

- Passive Conflict Areas are automatically set up by Vissim whenever Links or Connectors overlap. When activated, the main movement with right of way to enter the area (green) can be specified along with the minor yielding movement (red), or alternatively both movements can be given equal priority (both red);
- Conflict Areas prevent two vehicles being present in the defined area at the same time and use a number of different parameters to define how vehicles act in order to avoid this;
- Vehicles with right of way will brake or stop if there is a vehicle from the minor yielding movement blocking the area, and will avoid entering the Conflict Area if their exit is not clear based on the Avoid Blocking the Minor Flow percentage;
- Vehicles in the yielding stream will use gap parameters to decide when to cross / join the flow with right of way. They will also avoid entering the Conflict Area if their exit is not clear, unless the Avoid Blocking the Major Flow parameter is unchecked;
- For undetermined (both red) Conflict Areas, neither stream has priority and vehicles enter in the order in which they arrive; and
- Visibility parameters govern the point at which vehicles on each link can see the other.

7.4.2.6 Externally Generated Congestion

As indicated in section **B7.2.1**, there are situations where it may not be possible to include all junctions which generate congestion in the area of interest within the model boundaries. It is nevertheless important that this queuing is present in the model to properly represent the existing conditions. There are a few methods which can be used as a proxy to generate queuing; which one is the most appropriate depends on the cause of the congestion and the behaviour of the queuing traffic. This should be observed on site visits. The key aim is to match the observed capacity.

- RSAs: If the queue moves slowly and consistently then RSAs can be used. The speed distribution(s) used can be calibrated to generate the

desired behaviour and queue length. RSAs can also be applied only for a specific time period if the queuing changes throughout the peak. If necessary, more than one RSA could be used to cover different time periods, although care should be taken not to 'overfit' the data by using too many;

- **Stop Signs:** For queues caused by give-way junctions, Stop Signs may be effective. The Time Distribution can be calibrated to give the desired behaviour and capacity; and
- **Signal Heads:** Where queuing is caused by a signalised junction which is not being modelled, the simplest proxy is to add the single signal head (with a signal controller) which is causing the queue and give it the same timings as are found on street. If the behaviour is more complex, for example due to the interaction between multiple downstream junctions, then it is possible to add another signal head on a different signal controller running different timings. This will lead to more randomised queuing behaviour, and the capacity can be calibrated by adjusting the timings of this signal head.

7.4.3 Traffic Data

This section contains information on how traffic is modelled, including defining the characteristics of individual vehicles and specifying the number and composition of vehicles entering the model. There is also some information on modelling public transport, cycles and pedestrians.

7.4.3.1 Vehicle Models, Types, Categories and Classes

Vehicles can be categorised and grouped in various ways which are combined when vehicles are generated and acted upon.

- **Vehicle Types:** Group vehicles with the same technical driving characteristics;
- **Categories:** Define a vehicle's basic behaviour in traffic. Can be one of Car, HGV, Bus, Tram, Pedestrian, Bike;
- **Models:** Determine a vehicle's size and appearance. These are applied as a distribution so vehicles with the same driving characteristics can have more than one appearance;
- **Functions and Distributions:** Describe how the vehicle accelerates and decelerates, as well as the weight, power and occupancy. Further information can be found in section [B7.4.3.2](#);

- **Vehicle Classes:** These group Vehicle Types which share particular traits, for example, a Vehicle Class might contain all motorised vehicles or vehicles allowed in bus lanes. Network objects such as Routing Decisions, Detectors and Reduced Speed Areas operate on Vehicle Classes and they are also used to collect aggregated output data. A Vehicle Type can belong to more than one Vehicle Class; and
- **Vehicle Compositions:** These also group Vehicle Types but are used solely by Vehicle Inputs. They specify the proportion of each Vehicle Type generated by the Input. See section [B7.4.3.3](#) for further details.

Figure 131 below gives an example Vehicle Class to demonstrate how they fit together. Note that this is a simplified example and not a recommendation as to how this class should look.

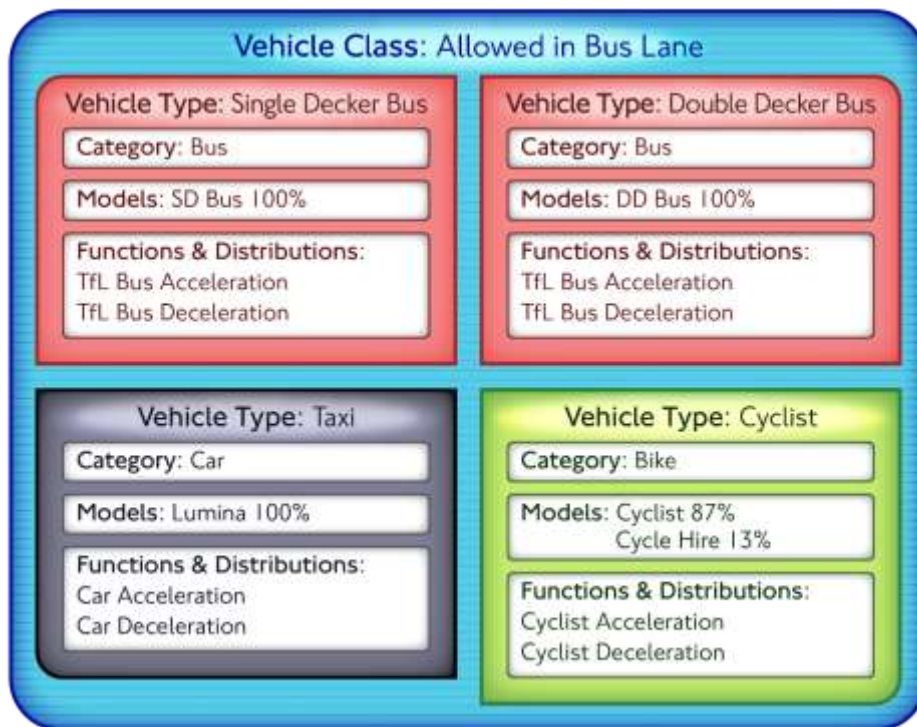

Figure 131: Example Vehicle Class

The default Vehicle Models and Types provided by Vissim are adequate for most networks. In addition to those defaults the following are often required for TfL models:

- Taxi: this can be a copy of the default 'Car' type and is often needed as taxi behaviour and routing can be significantly different from other road users;
- Double-Decker bus; and

- **MGV**: this type is often made up of Vehicle Models that cover a range of vehicle lengths / characteristics.

Other Vehicle Types can be created if supported by observation, survey results or where required by a scheme. For example, a scheme may be concerned with speed enforcement measures and so an additional Type could be included to model the behaviour of speeding vehicles. When creating Vehicle Types, it is essential that the correct Category is assigned to the Type, as Categories define certain rules of Behaviour. It is also important to check that the correct Functions and Distributions are assigned to the Vehicle Type; this is a common error and can seriously affect model calibration.

7.4.3.2 Functions and Distributions

Functions define the acceleration and deceleration of vehicles in the network, and without site evidence default settings should not be changed. TfL has conducted surveys of acceleration profiles for some vehicle types, notably articulated buses (no longer in use) and HGVs. These profiles can be obtained on request and provided via a template file supplied by TfL (section [B7.1.2](#)).

TfL has also developed a range of other speed distributions for cars, buses, cyclists and motorcycles, for different UK road speed limits and these are also included in the TfL Vissim Template (section [B7.1.2](#)). These distributions are based on data published by the Department for Transport¹⁰⁰.

7.4.3.3 Compositions and Demand

It is recommended that a Vehicle Composition is created for each Vehicle Type, so effectively each input Link has a separate Vehicle Input for each Vehicle Type. This means values can be transferred directly from survey data without the need to create any other Vehicle Compositions.

This method involves a significant amount of data entry if it is done manually so, alternatively, it is also acceptable to create Vehicle Compositions for input Links. If this method is used, it is not always necessary to create a vehicle composition for each input link. Survey data can be checked, and a practical decision made about the number of compositions to be used. A single composition should suffice where input links vary in composition by 10% or less. However, Links loading significantly different compositions should have specific Vehicle

Compositions, for example Links that load high proportions of taxis, HGVs or two-wheelers.

Traffic surveys usually come in 15-minute intervals, so this is the time period most commonly used for Vehicle Inputs. It is large enough to contain meaningful numbers of vehicles but small enough to show variations in flow across a peak hour. If a different length of time period is to be used, consideration should be given to the behaviour of the network, such as specific times of flow increases and decreases caused by events such as school runs and industrial site shift changes.

Vehicle inputs should specify 'Exact Volume' rather than 'Stochastic Volume' unless otherwise agreed. It is important to be aware that traffic volumes are defined for each time interval in vehicles per hour, even if the specified time period is different from one hour.

7.4.3.4 Public Transport

Public Transport Lines should be modelled as timetabled, so either TfL website data¹⁰¹ or iBus data (section **B7.2.2.5**) can be used. If iBus data is used, care should be taken to use the scheduled rather than actual data. This is so that any impact is part of the model performance, rather than built in.

As shown in **Figure 132**, public transport departure times can be entered with a start offset (Begin), a frequency (Rate), and an end time (End). In this way, start times can be adjusted if the frequency changes across the modelled period. At the beginning of the model, the start offset should be used to avoid buses from different routes all entering the model at the same time.

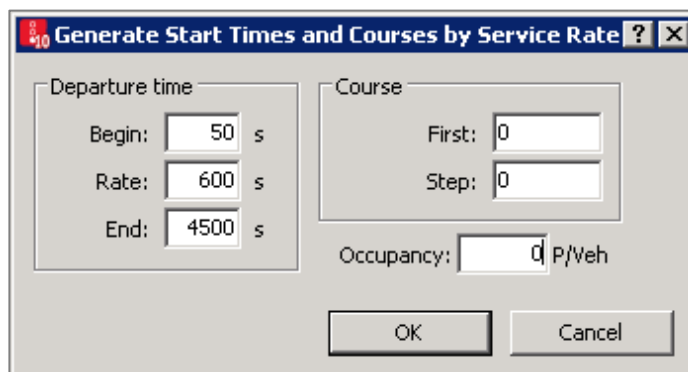

Figure 132: Public Transport Line departure times generator window

It is preferable that each Public Transport Line is given its own Vehicle

¹⁰¹ <https://tfl.gov.uk/travel-information/timetables/>

Type. This is to enable journey time reporting for each route independently.

7.4.3.5 Cyclists and Motorcycles

Cyclists should be included in any modelling work unless there is good justification for omitting them. Particularly in central London, cyclist outputs are often a key requirement. There are further details on modelling cyclists in Chapter **C2** on **Cyclist Modelling**. The TfL Vissim Template file (section **B7.1.2**) includes appropriate parameters to simulate cyclists in Vissim through altered Driving Behaviour and Link Behaviour types. As with all forms of modelling, the key point is to ensure the model replicates the situation on street as closely as possible, so adjusting parameters is acceptable if it can be justified.

For traffic engineering purposes, modelling two-wheelers in Vissim is more challenging than modelling general traffic. This is partly because this form of modelling is relatively new, and partly because their behaviour is less predictable. Some of the difficulties encountered in modelling two-wheelers in Vissim are:

- Measurement and calibration of saturation flow;
- Additional calibration effort for specific behaviour (lateral behaviour parameters);
- The lack of a consistent PCU value that is independent of flow; and
- Sensitivity of capacity to network characteristics (lane width in particular).

Modelling motorcycles has similar difficulties to modelling cyclists. In general, motorcycles do not take up much road space which could be used by other vehicles as they weave into gaps in queues, and they do not need special provision in terms of cycle lanes or separate phasing at junctions.

7.4.3.6 Pedestrians

Vissim models can include pedestrians modelled as small, slow moving vehicles, usually using the driving behaviour 'Footpath' with the 'No Interaction' following model. Generally, pedestrians are included in these models to activate demand-dependent pedestrian stages at signalised junctions or to replicate traffic delay occurring at un-controlled or zebra crossings.

In the case of un-controlled or zebra crossings the number of pedestrians using the crossing and controlling priority rules (or conflict areas) requires fine-tuning, supported by site observation, in order to achieve the correct

result. As with other network bottlenecks, sample counts of traffic passing the crossing will assist model calibration. Note that exact pedestrian numbers are not necessarily useful in this case, as the entities do not behave like real pedestrians and the only aim is to replicate the impact on other traffic.

Alternatively, Vissim models developed in version 5.1 or later are able to use a specific model (PTV Viswalk) for pedestrian behaviour. This approach, called the 'social force model'¹⁰², can be used in lieu of the 'small, slow moving vehicles' approach, where pedestrian behaviour is of interest. If the pedestrians are only being used to demand pedestrian stages at junctions then the social force model is not necessary.

Many schemes are interested in the interaction of vehicles with pedestrians and the effect they may have on each other. If modelling shared spaces or areas where pedestrians move between vehicles, the use of Viswalk pedestrians is recommended over the 'no interaction' pedestrian. Standard Vissim licences are restricted to 30 Viswalk pedestrians, which is usually insufficient for this type of modelling, so a licence with a larger number will need to be purchased. If full pedestrian modelling is being carried out in Viswalk then Chapter **C3** on **Pedestrian Modelling** should be consulted.

7.4.4 Routing

Routing in Vissim is either static, involving Routing Decisions which dictate the proportions of traffic heading to each destination via specified Routes, or dynamic, which is based on iterated simulations where traffic is assigned to paths based on results of preceding runs. TfL predominantly uses static routing, often with the route assignment carried out in tactical modelling and the resulting routes transferred to the Vissim model. The process of transferring routes between the modelling levels is undertaken during the Three Stage Modelling Process (section **B2.1.4**)

7.4.4.1 Static Routing

There are various methods of obtaining static routing information for a Vissim model. Which one is used is dependent on the data available and the complexity and size of the area to be modelled. The ideal scenario would be to have global OD information for each vehicle to be modelled and simply input this into the model. With the advent of GPS vehicle tracking this is closer to becoming a reality, however, at the time of

102 D. Helbing and P. Molnár (1995). Social force model for pedestrian dynamics. In *Physical Review E* 51(5), p. 4282-4286

publishing, only smaller networks that can be covered by cameras on all entries and exits have this complete dataset.

If tactical modelling is available for the modelled area, and particularly if it will be used to model the proposal, then routing information can be transferred to the Vissim model in the form of global OD routes. Since the Vissim model has to be validated against junction turning counts (section **B7.5.2.1**), it is important that the tactical model is updated to include these, and that the networks of the two models match. It is also necessary to verify that all the generated routes are realistic. Depending on the tactical model used, it may be possible to automate the route transference, but in general there is a certain amount of manual matching that must take place, even when tools are used to speed up the process.

Although the use of global OD routing is preferred, if global data or tactical modelling is not available, then junction turning counts can be converted into local Routes for each individual junction. Where this is done, close attention should be paid to any unrealistic weaving that may occur between the end of one Route and the start of another. It is also necessary to ensure that Routing Decision start points are placed sufficiently upstream of any Connectors to allow vehicles to get into the appropriate lanes without causing unrealistic congestion or blocking. In later versions of Vissim, the option Vehicle Routing Decisions Look Ahead is available in the Driving Behaviour parameters. If set, this enables vehicles to anticipate an upcoming Routing Decision on the destination Link of their current Route. The Route to be used from the upcoming Routing Decision is selected when the vehicle passes the previous Routing Decision, and that Route is used in lane choice decision making. A Routing Decision must have the flag Combine Static Routing Decisions set, in order to activate this behaviour. Once volumes have been finalised, it is possible to combine these routes together, however, care should be taken during this process as it may generate unrealistic routes, particularly at gyratories or where there is route choice. Even when local junction routing is used, it is desirable to have flows between junctions balanced as far as possible. Section **B2.3.4.1** highlights recommended methods for reconciling surveyed traffic flow differences within a modelled network.

Whichever method is chosen, Routes must be audited to ensure the correct Link-Connector sequence has been defined from start to finish. It is not acceptable to rely on the default path defined by Vissim. It should be noted that it is also possible to change the Connectors in a Route by accident when editing either spline points on the Route or Links and Connectors along the Route, so repeated checking during calibration is recommended. This also applies to Public Transport Lines.

Vehicle flows within Routing Decisions are relative. They can be specified as either proportions (percentages) or as total flow and this choice should be carried over to any future scenario models.

All Vehicle Inputs require at least one Routing Decision. In the absence of this, Vissim does not produce warnings, but routes traffic across the first Connector encountered (provided the Desired Direction attribute of the Connector is set to All). This is also the case if there is no Routing Decision for a particular Vehicle Type, so care must be taken that all Vehicle Types are covered, particularly when the Vehicle Classes specified in the Routing Decisions are not the same as the Vehicle Compositions used for the Inputs. The choice of how to group Vehicle Classes into Routing Decisions will depend on how the routing information is obtained, however, it is preferable to choose one system for the whole model rather than, for example, having most of the Routing Decisions split into Lights, Heavies and Taxis, with a few applying to All Vehicle Types. It is simpler for auditing purposes, as well as future users of the model, to be consistent.

7.4.4.2 Dynamic Assignment

Dynamic Assignment (DA) is a method of traffic assignment that assigns traffic to competing alternative routes, where they exist, based on the difference between the modelled costs on those routes.

In many cases, Vissim models developed for use in London do not include any significant alternative routes and using DA is therefore typically not necessary. Where route choice does exist within a model, it is often more appropriate to use available assignment models to inform routing.

It should be carefully considered whether the benefits of calibrating a model using DA are outweighed by the additional time required to calibrate the model. The decision to use DA should be agreed at MAP Stage I in order that all parties understand the additional time required to undertake the modelling.

In cases where dynamic modelling is justified, a combined static-dynamic assignment is preferred, with the proportion of DA based on consideration of routes which will not reassign under any circumstances. Where this is the case, OD demand matrices must be generated for the DA traffic. It is recommended to produce matrices at a minimum of 900-second intervals.

There are some special considerations and extra steps for the building of Vissim networks being developed with DA:

- Dynamic assignment nodes should be placed in the network at every junction or merge point;

- Link-connector structure should be as simple as possible in order to reduce the number of parallel routes through the network; and
- Route / edge closures may be required to remove unrealistic or duplicate routes.

The Vissim manual explains in more detail how to use DA within Vissim.

7.4.4.2.1 Convergence

The guidance provided in TAG¹⁰³ (section **A3.6.1**) on Assignment does not specifically cover microsimulation models and states that for microsimulation-based route choice:

“The concepts of equilibrium and convergence are difficult under such conditions and stability becomes a more crucial concern for microsimulation based assignments, particularly for models of large areas.”

TAG does not state any specific convergence requirements for DA models, however convergence should be monitored.

Convergence and model stability will be deemed to have been satisfactorily achieved when the following criteria have been met over the modelled peak hour:

- 95% of all path traffic volumes change by less than 5% for at least four consecutive iterations; and
- 95% of travel times on all paths change by less than 20% for at least four consecutive iterations.

Model convergence criteria will require analysis of path volumes and travel times after each simulation run. If convergence has been achieved for four iterations but is then lost in subsequent iterations, a note should be made of the number of iterations when convergence was achieved. Assignment and validation should then be performed with the use of the cost and path files (*.bew, *.weg) from the last of the four converged iterations.

Additional monitoring of the model through convergence using Vehicle Network Performance Indicators will give the modeller confidence of model stability. Two methodologies and additional troubleshooting that may help in achieving convergence using DA in Vissim are outlined in **Appendix IV**.

The methods and specific parameters used to converge a model should be reproducible and all steps must be documented.

7.4.5 Signal Control

Vissim has a few different methods of controlling signals. The two main methods used by TfL, and discussed in this section, are VAP and External. The external method in this case is UTC-Vissim, which refers to connecting a Vissim model to a simulated version of TfL's Urban Traffic Control system. Which method is used for a particular modelling project depends on the complexity of the project and signal control strategies, the required outcomes and whether it is possible to gain access to the UTC-Vissim Interface, which contains proprietary software.

7.4.5.1 VAP Controller Logic

For simple projects, or if UTC-Vissim is not available, VAP is the preferred method for implementing signal control logic and timings in Vissim, even for fixed time signal plans (section [B2.3.8](#)). VAP is flexible enough to model any UTC plan using phases, stages and intergreens as found in signal controllers on street. It can also run many of the features found in VA or MOVA junctions, although in this case the routines can get quite complex and simplifications may need to be agreed. Where it is necessary to simulate VA junctions, NP should be consulted and Controller Specification documentation should be thoroughly understood.

7.4.5.2 Demand-Dependent Stages in VAP

VAP is capable of accurately modelling demand dependency using either detector activations or directly input frequencies. Where a stage is called by vehicles on street then the VAP routine must use vehicle detection, and the frequency is determined by the number of vehicles making the movement. For pedestrian-only stages, however, there are two different options, both of which make use of demand dependency stage frequencies recorded from UTC (section [B2.3.8.5](#)):

- Use pedestrian Inputs and place Detectors in the model in a similar method to traffic stages. Even where pedestrian counts have been surveyed it may be necessary to adjust the flows further to achieve the desired frequency. The VAP function 'TRACE' can be used to generate calibration data which specifies the number of stage appearances relative to the number of demand-dependent opportunities; and
- Enter the UTC percentage directly into the VAP routine to automatically achieve the desired frequency.

7.4.5.3 UTC-Vissim

The UTC-Vissim Interface is a fully functional copy of the UTC system which controls London's traffic signals. It can be used to model many dynamic UTC traffic control scenarios including SCOOT, SASS, Gating and SVD Bus Priority without the need to use average signal timings. Each stream on street has a Signal Controller in the model, and all Detectors on street (SCOOT, bus, and demand) also have a modelled equivalent. These model objects are linked to their UTC counterparts via object naming conventions, so it is critical when setting up a UTC-Vissim model that all the elements are named correctly. This similarly applies to the model filename (*.inpx), which should not be changed once there are Signal Controllers in the model as links to the UTC controller configuration files will otherwise be lost. It is also important to ensure that all Detectors are activated by the correct Vehicle Classes so that, for example, regular vehicles do not activate the Detectors for bus priority.

Demand-dependent pedestrian stage frequencies can be directly entered into the UTC-Vissim Interface as a percentage based on observed appearance recorded from the UTC system. This facility should only be used for stages demanded by pedestrians where pedestrians are not being modelled. Any stages called by vehicle detection should be modelled using Detectors with the appropriate naming convention so that these stages are only called when relevant vehicles are present.

As indicated in **B7.2.2.2**, a UTC-Vissim model requires one or more UTC cells that have been copied from the live system at a particular point in time. This must then be checked to ensure that the signal control data matches that which was running on the day the model represents. NPD should be consulted to ensure the signal timings used are appropriate as they have access to historical UTC data.

NP must be consulted when a UTC-Vissim model is required. This is particularly the case since multiruns need special treatment to check that cells start correctly before each model run and are reset appropriately between model runs to ensure repeatability. Further technical advice is available from NP on request. It should also be noted that at the time of publishing TfL is in the process of upgrading its UTC system, so a new microsimulation interface is being developed (see **B2.3.8.2** for further details).

7.5 Base Model Validation

Base models must demonstrate that they replicate observed conditions to a sufficiently high level of accuracy, as described in **B2.4.1** and **B2.4.2**. This section describes validation requirements with respect to Vissim and section **B7.7** indicates how outputs can be obtained from Vissim to prove they are met.

7.5.1 Randomness

Traffic conditions vary day-to-day as a result of random driver behaviours such as speed selection, lane changing, route choice, bus and parked vehicle dwell times. The stochastic microsimulation traffic model in Vissim attempts to replicate this day-to-day random variability by altering individual driver decisions based on random numbers. The set of random numbers is generated from an initial 'seed' value specified at the start of a simulation run. A single set of random numbers, generated by a single seed value, therefore represents one potential outcome, or one particular day of traffic operation. The actual value of the seed has no significance; however, the seeds from different runs must be different from each other to produce different outcomes. Basing results on a single seed value has the potential to randomly bias the overall result.

An accepted method of reducing potential bias is to run several simulations using a range of initial seeds and to present mean average results. For this reason, both calibration and validation should be conducted using a minimum of 20 seed values, as stated in MAP.

Ideally any on-site surveys would be carried out over multiple days to mirror the number of seeds, however this is not usually possible. Where surveys are carried out on a single day, as is the case with most manual classified counts, observations should be conducted to ensure the traffic conditions are considered typical and unaffected by significant disruption. These observations can be backed up by analysis of background data, including SCOOT data and incident records. This checking reduces (or highlights) potential bias in the observed data and provides reassurance that it can be used to validate average microsimulation results (or an indication that the data collection exercise should be repeated on a more typical day).

It is important to note that the more saturated a network becomes, the more variable the results. This occurs because small adjustments in model behaviour (such as lane changes) have an amplified impact within a

congested network. It is usual that more simulation runs be used for saturated models. It is possible to calculate the number of simulations necessary to produce a reliable result if the required confidence level is known for a traffic model, but as a guide 20 simulation runs are normally sufficient.

The use of seed values should be described in technical notes. A sample range of results, using different seed values, should be provided for the validated Base model to demonstrate variability between simulation runs.

All seed values used should be included in the report. 'Cherry picking' seed values biased toward validation targets is not acceptable, so the seed values chosen should form a continuous range with a fixed increment. This also ensures that results can be easily reproduced. It is expected that the same seed values are carried over to Proposed modelling runs.

The initial random seed, seed increment and number of runs are set in the Simulation Parameters window (section [B7.4.1.3](#)).

7.5.2 Validated Model Requirements

Validated Base models are submitted during VMAP Stage 3, and all validation threshold figures quoted are from the latest version of MAP (section [B2.1.5](#)), at the time of publishing¹⁰⁴. It is required that the following outputs are reported to indicate that a model has been calibrated and is validated.

7.5.2.1 Traffic Flows

The GEH parameter ([Appendix II](#)) should be used to demonstrate that traffic flows within the model (on internal mid-links, stoplines and individual turning movements) match traffic counts to an acceptable level of accuracy.

When comparing modelled flow to observed flow volumes, the aim is for GEH values of less than five. However, GEH values of less than three are strongly recommended for all important / critical links within the model area. Results should be reported to include data showing all observed and modelled flows together with calculated GEH values. Modelled flows should be averaged over multiple seeds, as described in section [B7.5.1](#).

All entry links into the network are required to show modelled flows within 5% of observed flows. This requirement should be achieved, since

¹⁰⁴ SQA-0685, Model Auditing Process (MAP) – Traffic Schemes in London Urban Networks, Engineer Guide for Design Engineer (DE), Checking Engineer (CE) and Model Auditing Engineer (MAE), Version 3.5, Transport for London, March 2017

vehicle flows on external links are direct input values, and ensures that all assigned vehicle flows are being successfully loaded into the network during the peak modelled period.

7.5.2.2 Saturation Flows

Saturation flows are used to compare the discharge behaviour of the model at junction stoplines with on-street observation. All observed and modelled saturation flows should be tabulated and the percentage error between the two values reported. Modelled saturation flows values should be within 10% of observed values, or values used in any corresponding validated and approved LinSig or TRANSYT modelling.

During the process of calibration, time headways should be studied. This can be done using Discharge Record evaluation files in later versions of Vissim (section **B7.7.2.2**), or special evaluation files in earlier versions. The discharge record evaluation files should be filtered to remove measurements that do not correspond to saturated conditions (for example where there are very large headways). M&V can supply a spreadsheet-based tool which aids the filtering and processing of vehicle headway data. Alternatively, models can be viewed and measured as on street.

Wherever saturation flows have been measured on street during the relevant time period, providing the model is a fair representation of on-street conditions, it should be possible to measure saturation flows from the Vissim model. An inability to collect saturation flow data across a stopline in Vissim where it was successfully collected on street should be an indication that the model is not performing as desired.

It is possible, however, that saturation flows were measured on street at different times of the day in more appropriate conditions, or that RR67, possibly with a local factor (section **B2.3.9.1**), has been used to calculate a saturation flow.

There are times when a saturation flow cannot be measured within Vissim that is representative of on-street conditions, for example, where a stopline has low flows crossing it, or where downstream congestion causes queuing which prevents free-flowing movement over the stopline. If this is the case it is acceptable to make a copy of the model and modify it appropriately to generate the necessary traffic conditions. This may be by adding vehicles or removing causes of congestion. This model should be

submitted for auditing along with the main model, and appropriate reference made in the model report.

7.5.2.3 Demand Dependency

All demand-dependent stages within the network should show a frequency that is within 10% of that observed on street. The average count for each peak modelled should be reported and supplied along with any output files generated for each simulation run.

Demand dependency can be observed in the model or using the Signal Times Table (section **B7.7.2.5**), analysed from the Signal change model output (section **B7.7.1.1**), using TRACE files (*.trc) for VAP models, or checked in the UTC-Vissim Interface using a similar method to the live UTC system.

In UTC-Vissim models, a demand frequency for pedestrian stages can be entered into the settings so validation of these stages is not necessary. As stated in section **B7.4.5.3**, stages which are demanded by vehicles should use Detectors rather than being entered in settings, so it is a good idea to check these stage frequencies as if they are incorrect it may indicate a problem elsewhere in the model.

7.5.2.4 Journey Times

Modelled journey times should be averaged over multiple seeds, as described in section **B7.5.1**, and be within 15% of surveyed on-street journey times. Validating over longer journey time distances is favoured over shorter ones, although long journey times can be broken into smaller segments to identify problem areas. Journey time output can be analysed as the cumulative journey time obtained by all vehicles that follow smaller journey time segments, as well as complete journey times for vehicles that follow the entire journey time surveyed route. **Figure 133** shows an example of using the cumulative journey times of smaller segments (1 to 8) to indicate the location of a validation problem (segment number 4) with the whole route journey time, which means more modelling focus can be applied to this area.

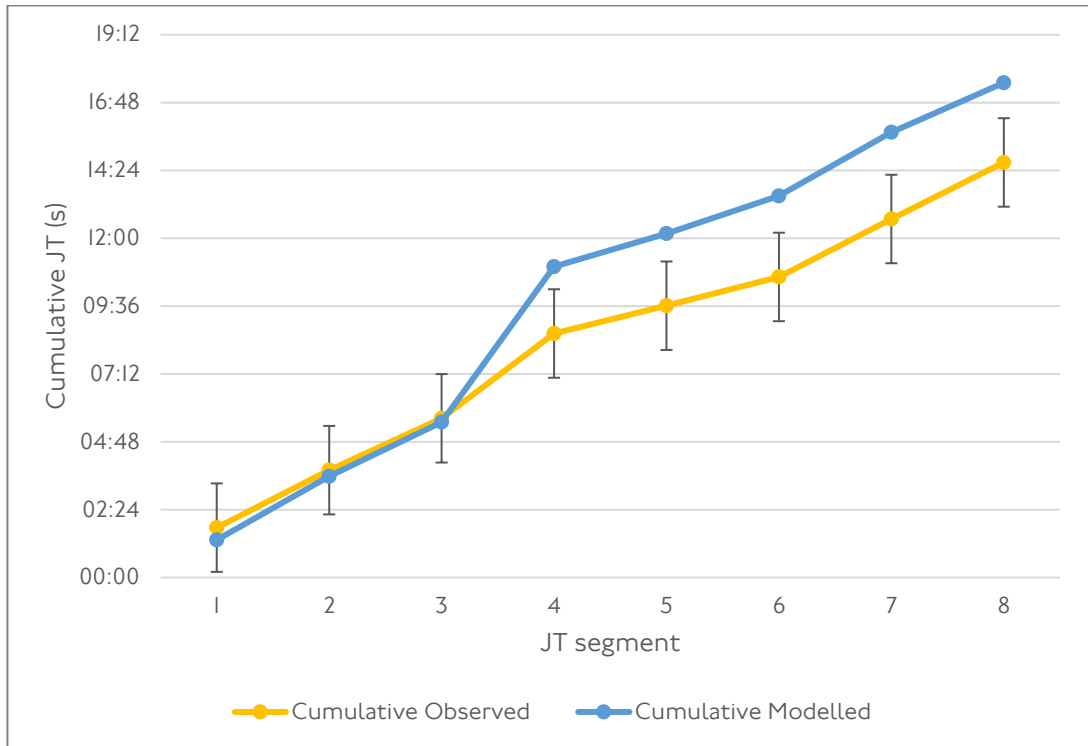

Figure 133: Example of cumulative observed vs. modelled journey times

Travel Time Sections should match the distances over which the data was collected on street as closely as possible. Information on how to output journey time data for validation can be found in section [B7.7.2.3](#).

7.5.2.5 Queue Data

Given the difficulty of measuring queue lengths on street in the same way as in a model, a direct comparison of simulated vs. observed queue lengths is not a validation criterion; journey time validation is a more reliable indicator of congestion levels. Queues should, however, appear in the model at the same locations and during the same time periods as they are observed in reality, and queuing behaviour in the model should be consistent with site observations.

Queue survey data is useful when determining bottlenecks within a network. It can be used as a measure of the model's performance and for direct comparison with scheme proposals. Modelled and surveyed queues should be compared and presented in accompanying reports. Section [B7.7.2.4](#) contains information on queue length output in Vissim.

7.5.2.6 Public Transport

Similarly to general traffic, modelled public transport journey times should be averaged over multiple seeds and should be within 15% of surveyed on-street journey times. As mentioned in section **B7.4.3.4**, it is preferable to report on each route separately, although this is dependent on the purpose of the modelling. Any grouping of routes for reporting or validation purposes should be agreed in advance.

Counts should be checked to ensure that there are no problems with the inputs or Travel Time Sections, and that no buses are being removed from the network due to modelling issues.

7.5.2.7 Error Files

Vissim generates error files (*.err) while running, which should be analysed after the simulation run. If there are any VAP Signal Controllers in the model, a VAP error file is also generated. These files should be thoroughly audited as they may contain indication of errors such as:

- Vehicles and Public Transport Lines being removed from the network;
- Vehicles reaching the end of links while still searching for routes;
- Vehicles not being loaded onto the network (latent demand). Note that in later versions of Vissim this is only reported at the end of the simulation, rather than for each time interval;
- Circular routes indicated by Travel Time measurements;
- Minimum green and/or minimum stage length violations; and
- Unusual stage change sequences.

Ideally, no error files should be produced at the end of the simulation runs. However, small error files with non-critical error messages are acceptable within VMAP.

In later versions of Vissim, errors in the network are displayed in the Messages window. This allows errors to be checked prior to and during a simulation run. Between runs, this window offers an opportunity to fix the errors.

7.5.3 Use of Multithreading

The use of multiple processor cores may help Vissim to run faster. Since version 5.30, Vissim output data can be reproduced when using multiple processor cores. The use of multithreading is therefore recommended during model development and validation.

7.6 Proposed Model Development

As is outlined in section **B2.5**, the Proposed model should be implemented in the Base model (or Future Base model if the Three Stage Modelling Process is being followed, see section **B7.6.1** below) by only modifying elements which will change as part of the scheme, including any signal timing changes. Adjusting other elements, which will not change on street, 'to make it work better' is not acceptable. If the Proposed model will not work without additional changes then this is a sign that either the proposed design is not viable or the Base model was not fit for purpose and should be revisited. As noted in section **B7.1.2**, the same version of Vissim must be used for Base and Proposed scenarios.

This section deals with aspects which particularly need to be considered when building a Proposed Vissim model. For a more general overview refer to section **B2.5**.

7.6.1 Future Base

The Future Base model bridges the gap between Base and Proposed scenarios and provides a reference when analysing the Proposed results. As described in section **B2.5.1**, the Future Base model includes all likely network changes which will occur between the base year and the year being examined in the proposal, excluding the scheme under consideration. It is built from the Base model by changing as little as possible in relation to each new scheme that has been identified to be added. The guidance in this section applies to creating the Future Base model as well as to the Proposed scenarios.

7.6.2 Scenario Management

The preferred method for generating a new scenario is to copy the model folder and use the copy to build the Proposed model. Alternatively, however, Scenario Management may be useful when testing different options. The scenarios are set up with a Base network that is common to all scenarios. Once Scenario Management has been enabled via File > Scenario Management > Place Under Scenario Management... scenarios are controlled in the Project Explorer window (**Figure 134**).

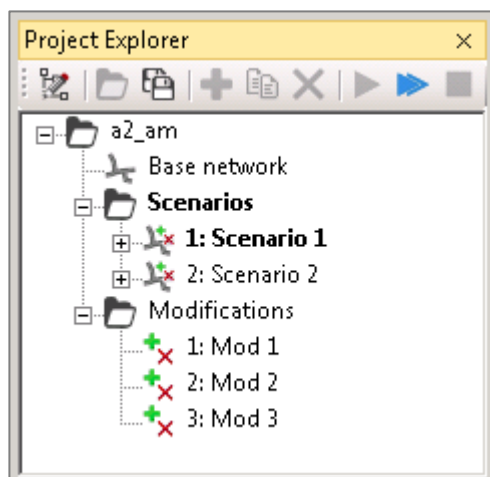

Figure I34: Screenshot of Project Explorer window

Care must be taken when using Scenario Management with external signal control files, as changing timings in one file will affect every scenario which uses it. With VAP control (section [B7.4.5.1](#)), this can be solved by using separate VAP (*.vap) and PUA (*.pua), if necessary, files for each scenario, however, with UTC-Vissim (section [B7.4.5.3](#)), this is not possible as the signal configuration files are linked to the model input file name (*.inpx). For this reason, it is preferable that Scenario Management is not used with UTC-Vissim models and a copy of the model folder is made for each scenario. It is recommended that if Scenario Management has been used for any interim modelling a full description should be added for each scenario and any modification files.

It is down to personal preference as to whether the use of Scenario Management would be beneficial in comparing scheme options, however, as indicated in section [B7.3.4](#), each scenario should be submitted to TfL for auditing as a single model input file (*.inpx).

7.6.3 Proposed Flows and Routing

Proposed flows and routing can be obtained in a number of different ways. The methodology should have been agreed in the MAP Stage 4 Proposal Scoping Meeting (section [B2.1.5.1](#)), but also considered at the MAP Stage I Base scoping meeting as the Base model build will dictate the appropriate methods for the proposal, to some extent. The methodology should be suitable for the purpose and timescales of the modelling. Once the new routing is implemented, the advice in section [B7.4.4](#) still applies with regard to checking that the routes function properly.

Future year flows of cyclists and pedestrians is usually decided on a project basis. Refer to Chapter [C2](#) on [Cyclist Modelling](#) and Chapter [C3](#) on [Pedestrian Modelling](#) for further details.

7.6.3.1 Input Adjustments

The simplest method is to use the same Routing Decisions, with a percentage change, or no change, to the Vehicle Inputs. This is most likely if tactical modelling is not being used. If this is the case, then any network changes involving Link-Connector sequences should avoid breaking the existing Routes. After the network changes have been made, the full length of Routes must be checked as it is possible to change the Link-Connector sequence when adjusting Connectors.

This method can be complicated if movements are banned or introduced as part of the proposal. For example, a turning movement at a junction may be removed for safety or efficiency reasons. In this case, a decision must be agreed as to how traffic should be rerouted. If the rerouting is likely to be widespread then tactical modelling may be necessary.

Conversely, a new traffic source / sink may be added as part of a proposed development. In the absence of tactical modelling, this extra traffic can be modelled by leaving existing flows and routing in place and introducing duplicate Vehicle Types and Vehicle Inputs with separate Routing Decisions leading to and from the new location. These would be informed by projections of the usage of the proposed development.

7.6.3.2 Tactical Modelling

As explained in section **B2.5.2.2**, the Three Stage Modelling Process will often lead to routing information for Vissim models being transferred from tactical modelling. If this is the case, the tactical routing can be transferred directly into the Vissim model. The tactical flows should be used to assess the change in flow from the Base tactical model. Each traffic input in the microsimulation model should be reviewed to determine whether applying a factor or an absolute change in flow from the Base model is more applicable.

Any changes made to tactical routing in the Base model for validation purposes should be carried across appropriately to the Proposal.

7.6.4 Proposed Signal Timings

Signal timings in VAP models are updated by creating new VAP files (*.vap), along with new PUA files (*.pua) if the method of control (section **B2.3.8.1**) has changed. The new signal timings will come from an optimised deterministic model or models, which include any junctions whose timings may be changed by the proposal. Once these have been imported, the timings can be refined in Vissim to meet any scheme objectives.

Signal timing changes in a UTC-Vissim model (section **B7.4.5.3**) should be made in a copy of the Base cell, so the Base model can still be run against the original cell. The link to the cell must be updated in the Simulation Parameters. It is often the case, however, that even in UTC-Vissim models new junctions will have signal timings implemented using VAP, while the rest of the model continues to run UTC-Vissim. As with VAP models, the new signal timings would come from optimised deterministic models. The remaining junctions run their original timings, or may be used to test mitigation measures, depending on the needs of the project.

Demand dependency levels should be carefully considered if there is reason to believe they will change from the Base scenario (**B2.5.2.3**). Assuming full demand as a worst case could mask a capacity issue downstream so a judgement on the expected levels must be agreed.

Any new methods of control will need to be signed off for SQA-0640 compliance as part of VMAP Stage 5.

7.6.5 Proposed Saturation Flows

Saturation flows should only be changed from the Base model if there is clear evidence that they would be different in the Proposed scenario.

Reasons for this include:

- A new junction or major layout change;
- Change in lane width; or
- Change in flow volumes for particular turning movements.

If any of these apply then RR67, with an appropriate local factor (section **B2.3.9.1**), should be used to implement new saturation flows using the methods described in section **B7.4.2.4**. The reasoning behind any changes must be documented in the modelling report.

7.6.6 Proposed Public Transport

Any changes to public transport must be coded into the Proposed model. These may include routes that have been diverted due to the proposal, bus stops which have been moved and bus lanes that have been introduced or removed. It is also possible that dwell times may be adjusted, for example due to stops for different routes being combined or split, or a new development which is expected to generate more bus passengers. Any change in dwell times must be justified in the report.

7.7 Model Outputs

Vissim can output data for analysis in a variety of different ways, depending on the type of data and how it will be used. The most commonly used outputs of earlier versions of Vissim were all in the form of text files, which were generally imported into spreadsheets for analysis. In later versions the situation is more complex; there are various interlinked methods for accessing the results of models, which are described in the following section.

7.7.1 Methods

Vissim has the capability to output data in various formats, both during and after a simulation run, and also provides facilities to visualise different data while the model is running.

7.7.1.1 Numerical Outputs

Different types of numerical outputs are available, including:

- The List window for each type of result. With the addition of UDAs, these can be used to display validation results directly, or they can be copied to spreadsheets for further analysis;
- Attribute (*.att) files, which are text files that can be exported from the List window either during or after the simulation;
- Database (*.db) files, which are saved to the **<model filename>.results** folder in the model folder. They contain the data which populates the List windows so deleting them will remove the data from Vissim. They can be accessed directly through a database or SQL reader; and
- Text output files are still available for certain parameters, but generally only for raw (rather than compiled) data.

Whether results get generated at all, and also some of the configuration settings, are determined in the Evaluation Configuration window. The Result Management tab (**Figure 135**) determines whether anything is recorded:

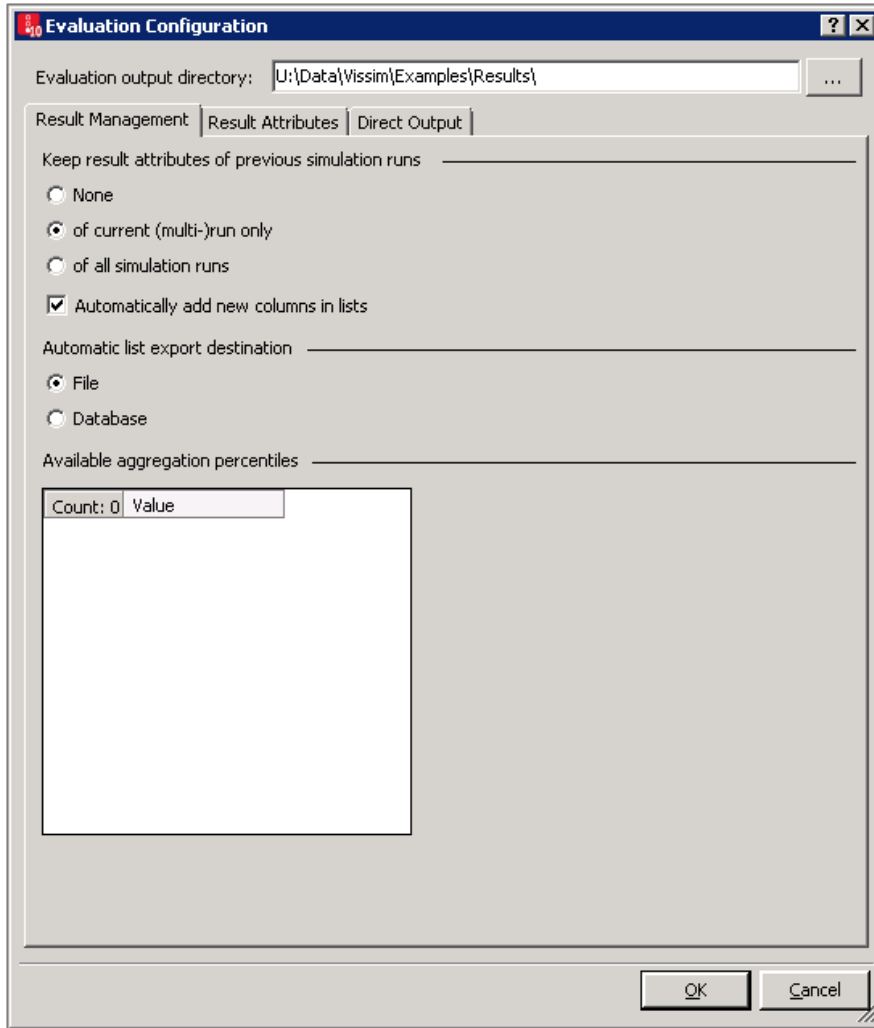

Figure 135: Evaluation Configuration window, Result Management tab

The Results Attributes tab (Figure 136) controls the data which appears in the results List windows, including the time periods and intervals it is collected over. This tab also contains the list of Vehicle Classes the data will be collected and aggregated for. The Direct Output tab (Figure 137) controls the data which is written to text files.

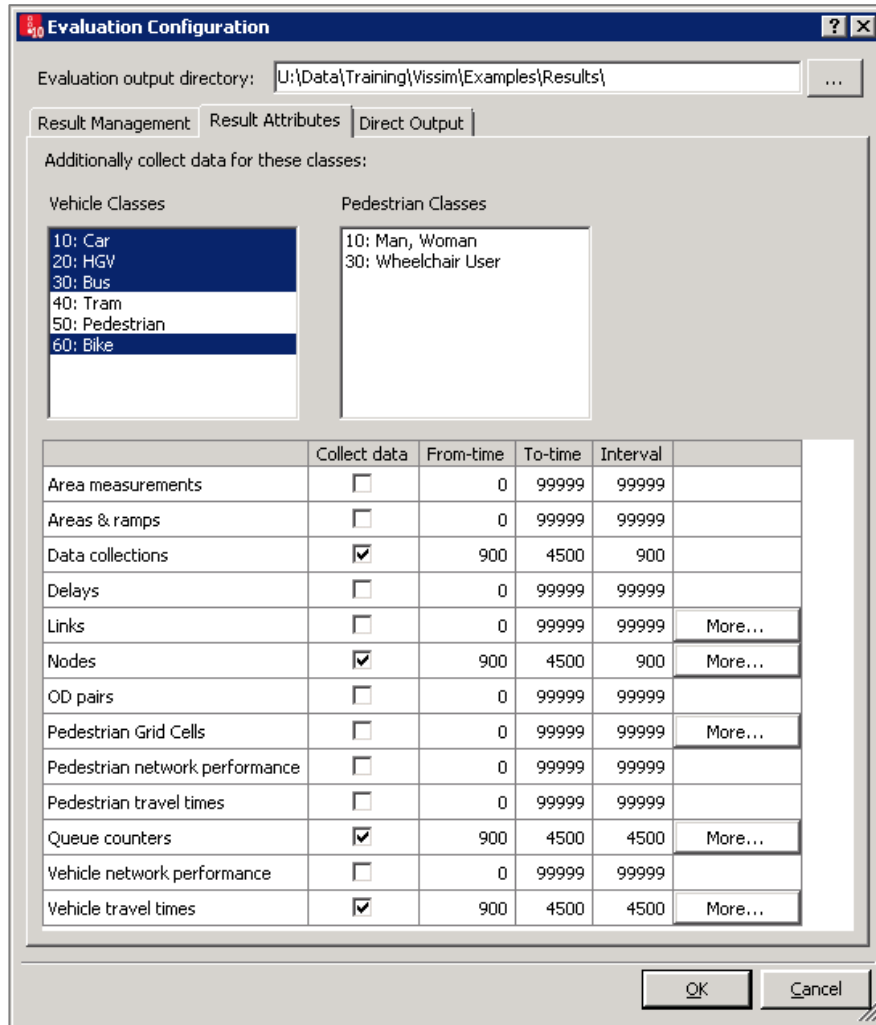

Figure 136: Evaluation Configuration window, Result Attributes tab

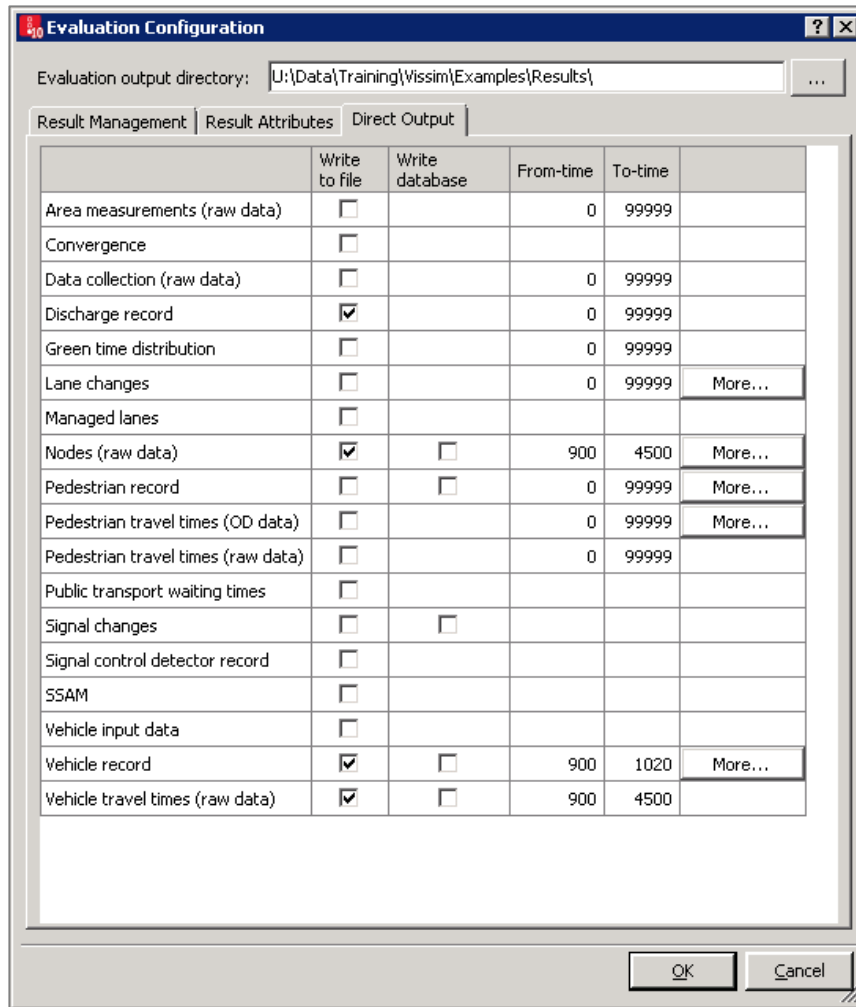

Figure 137: Evaluation Configuration window, Direct Output tab

The controls to output Attribute files are found in the individual results List windows (Figure 138). The buttons can be set to automatically output the file after the simulation run, or a file can be output manually, containing the data that is currently in the List.

Count	SimRun	TimeInt	VehicleTravelTimeMeasurement	VehicleTravelTimeMeasurement\Name	Vehs(All)	TravTm(All)	DistTrav(All)
19	1	1800-2700	202: A2_02b_20-19	A2_02b_20-19	39	245.72	1283.22
20	1	1800-2700	203: A2_03_19-18	A2_03_19-18	111	76.41	567.83
21	1	1800-2700	204: A2_04_18-17	A2_04_18-17	252	118.01	632.52
22	1	1800-2700	205: A2_05_17-16	A2_05_17-16	98	57.83	302.09
23	1	1800-2700	206: A2_06_16-15	A2_06_16-15	80	396.30	838.61
24	1	1800-2700	207: A2_07_15-14	A2_07_15-14	220	55.24	386.47
25	1	1800-2700	208: A2_08_14-13	A2_08_14-13	211	84.55	757.61
26	1	1800-2700	209: A2_09_13-12	A2_09_13-12	154	193.11	1537.39
27	1	1800-2700	211: A2(A102)_06_632-88	A2(A102)_06_632-88	99	146.21	1486.75
28	1	1800-2700	213: A2(A102)_08_87-77	A2(A102)_08_87-77	272	76.18	1605.32
29	1	1800-2700	214: A2(A102)_09_77-76	A2(A102)_09_77-76	360	56.20	1267.62

Figure 138: Results List window

7.7.1.2 Network Object Display

As mentioned in section [B7.3.1](#), the Network Objects window controls how objects are displayed. Various options are available in the Edit Graphic Parameters box, depending on the network object. These options include:

- **Label Attribute:** can show, for example, the Link name, Signal Controller number or Detector name;
- **Label Colour Scheme;**
- **Colour scheme:** can display simulation data including Link volumes, speeds (shown in [Figure 139](#)) or UDA values; and
- **Link bar:** shows similar data to a Link colour scheme in bar form.

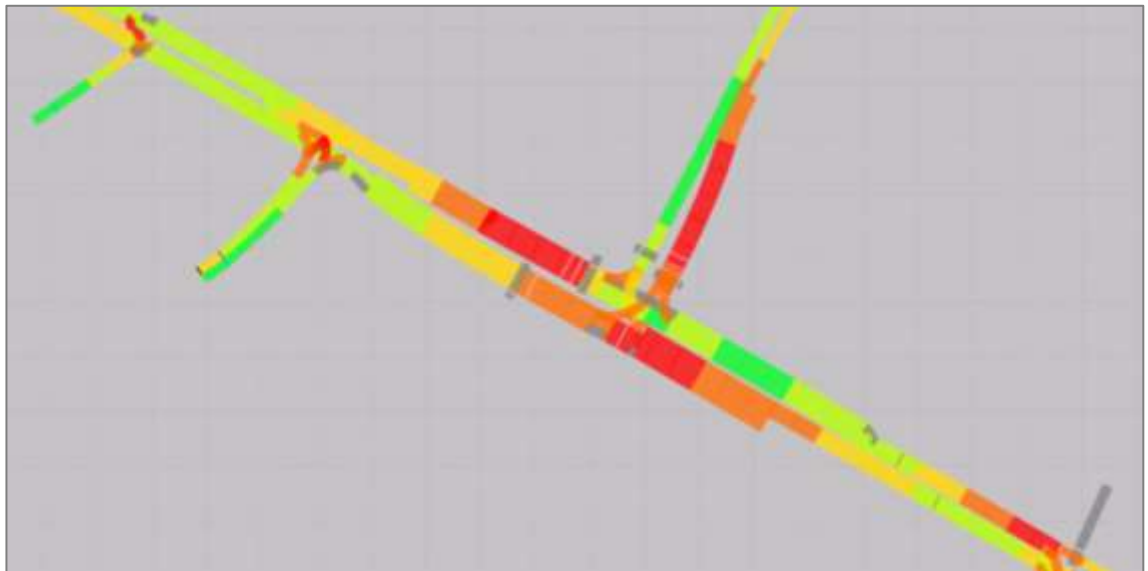

Figure 139: Links with a colour scheme based on speed

7.7.1.3 Charts

The Create Chart option in the View menu provides the ability to create bar or line charts of input data, attributes of objects in the network or results data. Charts can also be created by selecting appropriate data in a List, right-clicking, and choosing the Create Chart option. [Figure 140](#) shows an example Chart displaying Delay Measurements. Depending on the data type, the Chart will display instantly or update during the simulation. Note that Charts do not update when Quick Mode is active. If required, Charts can be exported as an image file or copied and pasted into another program.

More information on how to set up and adjust the settings for Charts can be found in the Vissim User Manual¹⁰⁵.

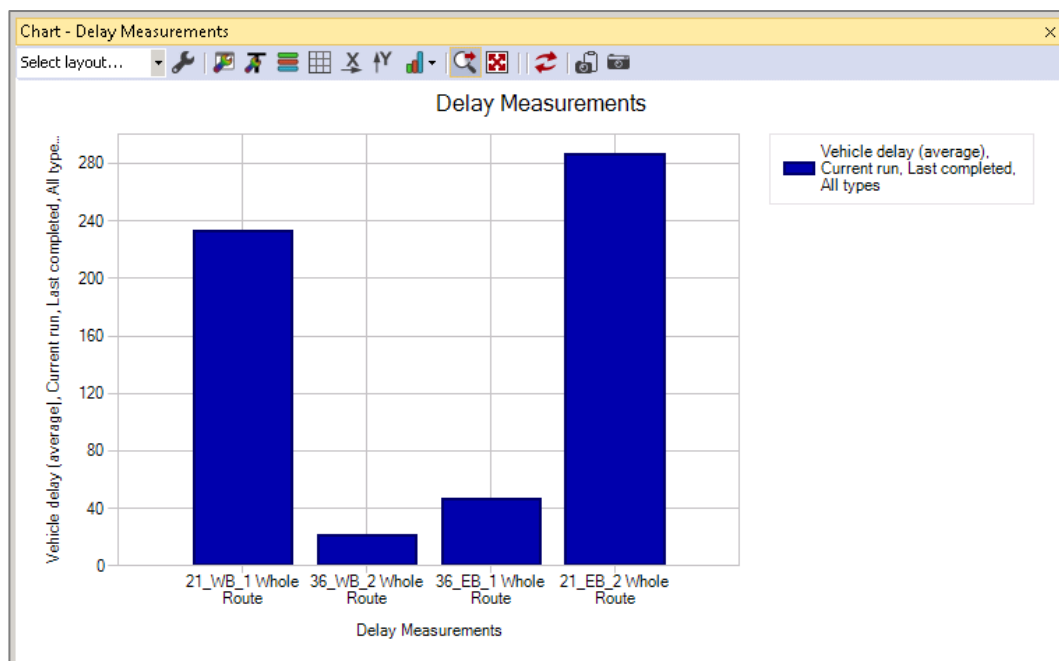

Figure 140: Example of a Chart

7.7.1.4 Scripting

Vissim scripting, using Python, can be used to automate various tasks including importing and exporting model data. Further information on the key classes and functionalities provided by Vissim can be found in the Vissim scripting documentation, which can be found under the Help menu.

7.7.2 Data

While the section above gives general guidance on extracting data from a model, this section provides specific advice on generating the commonly used data outputs.

7.7.2.1 Traffic Flows

A convenient method for assisting with traffic flow calibration and validation is Node Evaluation. This can be output as a raw file or displayed in a List window, which can be directly copied and pasted into a spreadsheet or exported as an Attribute file. All critical junctions can be defined as Nodes, from which Vissim can collect multiple pre-defined

parameters for every turning movement, Vehicle Type and time period. Such parameters can include traffic flow by Vehicle Type, average delay by Vehicle Type, average queue lengths per Link and maximum queue lengths per Link.

Since the movements that are evaluated rely on the Link-Connector structure in the model, it is important to set up the Nodes in a consistent manner, taking into account all the surrounding geometry. Nodes should include all Connectors which carry junction turning movements and cut through as few Links as possible. Older versions of Vissim run slowly with more than ten Links crossing any Node boundary, so if the road layout requires more than this then Travel Time Sections can be placed across each turning movement as these also collect vehicle counts. Depending on the Link structure, it may be necessary to include one or two intermediate Nodes in between pairs of junctions. An example is shown in **Figure 141**. The Nodes should have Use for Evaluation checked, and Dynamic Assignment should be unchecked as this speeds up simulation times.

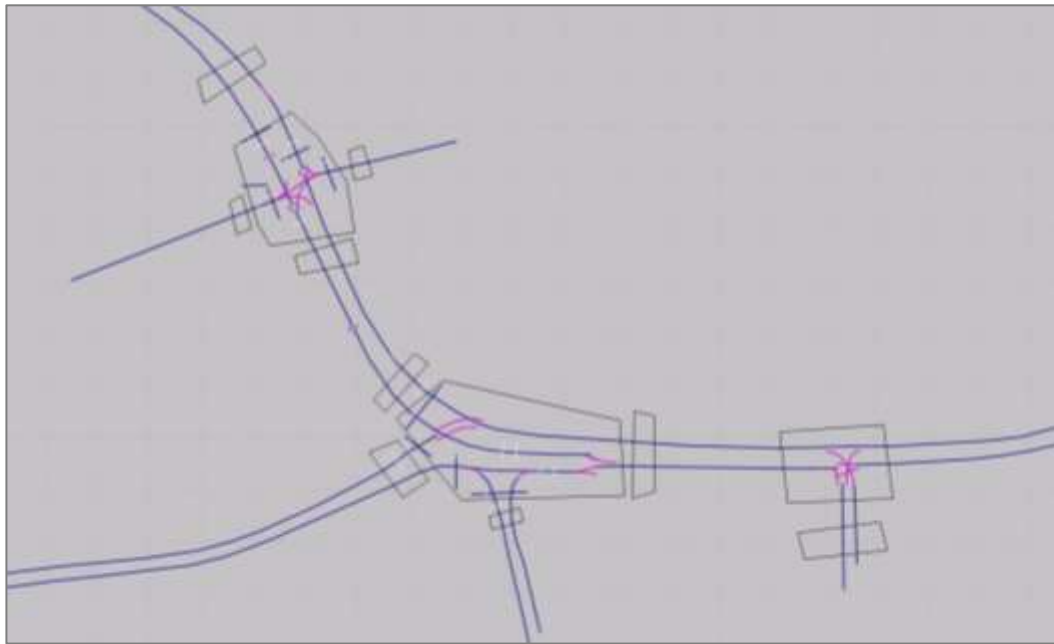

Figure 141: Example Node layout

Alternatively, when observed traffic data is entered in Vissim as a Link or Connector UDA, the GEH per movement can be calculated by using the specific GEH formula UDA. Once the GEH has been calculated, the values can be visualised on the Links or as labels in different colours, which gives an indication of where to target calibration effort (section **B7.7.1.1**).

7.7.2.2 Saturation Flows

As mentioned in section **B7.5.2.2**, saturation flows in later versions of Vissim are measured by using Discharge Record evaluation files (*.dis). These are activated individually for each Signal Head (**Figure 142**), and Discharge Record must be turned on in the Direct Output tab of the Evaluation Configuration window (section **B7.7**). A saturation flow validation spreadsheet can be provided by M&V.

The screenshot shows the 'Signal Head' configuration dialog box. The 'Discharge record active' checkbox is checked and highlighted with a red box. Other settings include:

- No.: 1
- Link - lane: 1 - 1
- SC - Signal group: 1 - 1
- Type: Circular
- Rate of compliance: 100.00 %
- Is block signal:
- Amber speed: 0.00 mph
- Show label:
- Vehicle classes: All vehicle types
- Vehicle classes list:
 - 1: All Motorised
 - 2: JT
 - 10: Car
 - 20: HGV
 - 30: SD Bus
 - 40: Tram
 - 50: Pedestrian
 - 60: Cyclist
 - 70: Motorbike
 - 80: Artic Bus

Figure 142: Setting to record saturation flows from Signal Heads

7.7.2.3 Journey Times

Journey times are collected using Travel Time Measurements, which can be set up between any two points on the network, even if there is no route between them (although, in this case, they would record nothing). If there is more than one route, Vissim will count any vehicle which crosses the start and end markers regardless of the route in between, so care should be taken when there is route choice in the model.

Travel Time data can be output as a raw file or aggregated in a List window. The aggregated data is usually used for validation as it is easier to work with. Different Vehicle Classes can be set up to study each Vehicle Type separately as well as aggregating them together. To make sure of collecting the appropriate Vehicle Types it is good practice to set up a Vehicle Class specifically for journey time measurements. The travel times options should be set to aggregate by time of passing the destination section, as in **Figure 143**, so that model results do not change depending on whether a cool-down period is run or not.

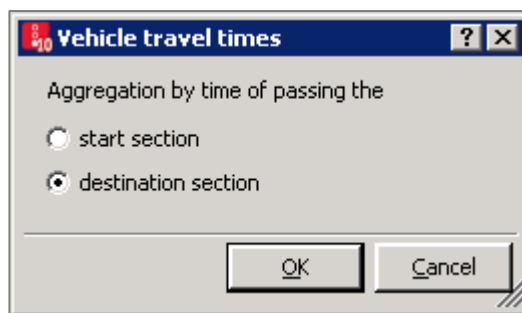



Figure 143: Vehicle travel times setting

7.7.2.4 Queue Data

As mentioned in section **B7.7.2.1**, average queue lengths per Link and maximum queue lengths per Link can be output using Nodes. In addition, Queue Counters can be set up where required in the network, and these output aggregated data in a List window.

It should be noted that Vissim measures queue lengths according to a set of parameters based on vehicle speeds and headways. Changing these parameters will result in different queue lengths being reported where in fact queues have not actually changed. Apart from the Max Length, the default queue configuration parameters should be used. The Max Length should be checked, and increased if necessary, to ensure all modelled queues are properly captured.

Queue length data is available in later versions of Vissim as a graphic parameter for Queue Counters and/or Nodes as shown in **Figure 144** below.

Show queue lengths	<input checked="" type="checkbox"/>
Queue length attribute	QLenMax(Current,Avg)
Queue length color	 (150, 219, 164, 255)
Show queue length label	<input checked="" type="checkbox"/>

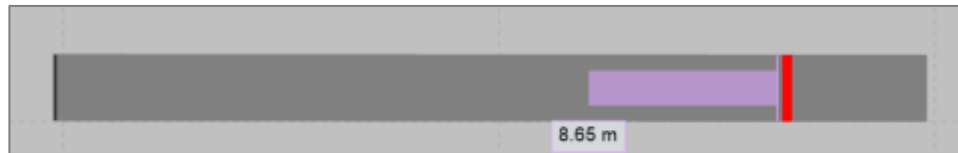

Figure 144: Queue length bars

7.7.2.5 Signal Timings

Signal timings can be output as raw data, using the Direct Output tab, with a line written every time a Signal Group changes state. The data includes the Simulation Time, cycle time, Signal Controller, Signal Group, and colour of the signal. Signal timings can also be checked while the simulation is running using Evaluation > Window > Signal Times Table (Figure 145). This displays the selected Signal Controllers in a format similar to that used in LinSig or TRANSYT, which means this is usually the easiest method of determining whether signal timings are correct. It can also be used as a visual check that all stages are being called.

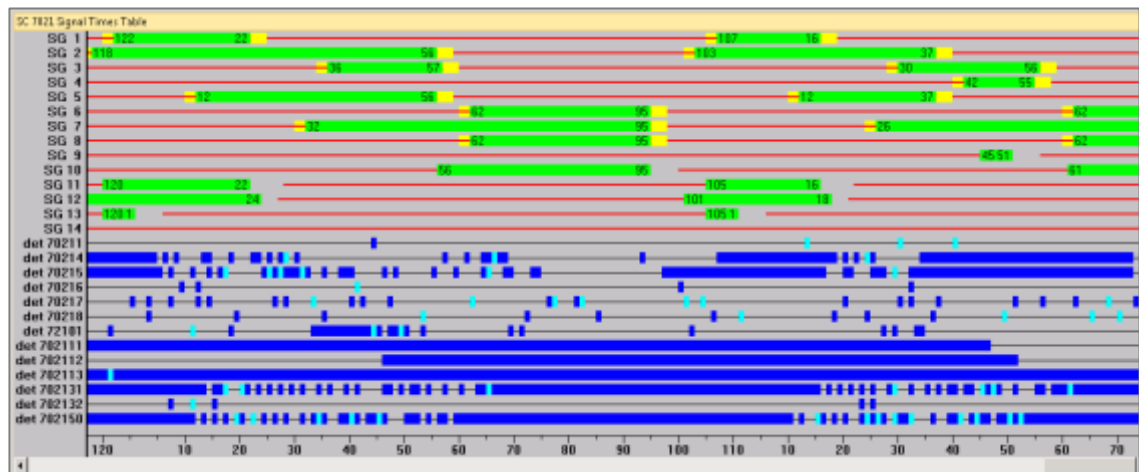

Figure 145: Signal Times Table

7.7.2.6 Network Performance

A quick method for indicating the performance of a network is the Vehicle Network Performance Evaluation (**Figure 146**), which is output in a List, as described in section **B7.7.1.1**. This outputs network-wide performance statistics such as stops, delay and speed for all vehicles and also the Vehicle Classes specified in the Result Attributes tab, which allows for a simple cost / benefit analysis.

Count	TimeInt	DelayAvg(All)	DelayAvg(10)	DelayAvg(60)	DelayAvg(100)	DelayAvg(201)	DelayAvg(30000)	StopsAvg(All)	StopsAvg(10)	StopsAvg(60)	StopsAvg(100)
1	900-1800	162.52	172.60	57.22	197.62	108.91	163.63	3.46	3.53	3.52	4.94
2	1800-2700	247.49	261.48	67.52	224.47	228.94	175.34	4.07	4.10	3.80	4.91
3	2700-3600	333.73	353.91	67.41	247.76	310.76	226.67	4.32	4.34	3.99	5.43
4	3600-4500	338.74	357.55	75.91	265.57	364.12	191.77	4.98	5.03	4.92	3.90

Figure 146: Vehicle Network Performance Evaluation Results

7.7.2.7 Vehicle Trajectory Files

Vissim can output vehicle trajectory text files for a variety of uses, for example, emissions modelling, data visualisation and 3D animations. There are two different output files:

- Animation files (*.ani.txt), include vehicle and pedestrian positions over time (**Figure 147**), which are primarily for 3D animations and work with PTV's 3ds Max import MAXScript. Apart from specifying the time period and area of coverage, these files are not configurable. They are not available on a standard Vissim licence and require the Export 3DS MAX module; and

```
0,1500,00
2502,0,1,"",[0,000000,0,000000,0,000000],[0,000000,0,000000],[0,0,0],[0,0,0],[0,0,0],[0,0,0],[-1,1.000000,1.000000,0,0,0
2445,0,1,"",[0,000000,0,000000,0,000000],[0,000000,0,000000],[0,0,0],[0,0,0],[0,0,0],[0,0,0],[-1,1.000000,1.000000,0,0,0
2153,0,1,"",[0,000000,0,000000,0,000000],[0,000000,0,000000],[0,0,0],[0,0,0],[0,0,0],[0,0,0],[-1,1.000000,1.000000,0,0,0
2389,0,1,"",[0,000000,0,000000,0,000000],[0,000000,0,000000],[0,0,0],[0,0,0],[0,0,0],[0,0,0],[-1,1.000000,1.000000,0,0,0
2516,0,1,"",[0,000000,0,000000,0,000000],[0,000000,0,000000],[0,0,0],[0,0,0],[0,0,0],[0,0,0],[-1,1.000000,1.000000,0,0,0
2585,0,1,"",[0,000000,0,000000,0,000000],[0,000000,0,000000],[0,0,0],[0,0,0],[0,0,0],[0,0,0],[-1,1.000000,1.000000,0,0,0
2445,0,1,"",[0,000000,0,000000,0,000000],[0,000000,0,000000],[0,0,0],[0,0,0],[0,0,0],[0,0,0],[-1,1.000000,1.000000,0,0,0
2565,0,1,"",[0,000000,0,000000,0,000000],[0,000000,0,000000],[0,0,0],[0,0,0],[0,0,0],[0,0,0],[-1,1.000000,1.000000,0,0,0
2764,0,1,"",[0,000000,0,000000,0,000000],[0,000000,0,000000],[0,0,0],[0,0,0],[0,0,0],[0,0,0],[-1,1.000000,1.000000,0,0,0
2430,0,1,"",[0,000000,0,000000,0,000000],[0,000000,0,000000],[0,0,0],[0,0,0],[0,0,0],[0,0,0],[-1,1.000000,1.000000,0,0,0
2462,0,1,"",[0,000000,0,000000,0,000000],[0,000000,0,000000],[0,0,0],[0,0,0],[0,0,0],[0,0,0],[-1,1.000000,1.000000,0,0,0
2585,0,1,"",[0,000000,0,000000,0,000000],[0,000000,0,000000],[0,0,0],[0,0,0],[0,0,0],[0,0,0],[-1,1.000000,1.000000,0,0,0
2484,0,1,"Lumina",[532765,567572,182396,975518,0,000000],[-1,414554,0,000000,[0,0,0],[211,211,0],[24,24,0],[0,0,0],[0,5.009999,1.700000,0,0,0
1880,0,1,"Lumina",[532756,745003,182524,923445,0,000000],[-2,23927,0,000000,[0,0,0],[211,211,0],[24,24,0],[0,0,0],[0,5.009999,1.700000,0,0,0
1578,0,1,"486",[532732,569909,182473,735582,0,000000],[1,259530,0,000000,[128,128,192],[0,211,0],[0,24,0],[0,0,0],[0,4.610003,1.700000,0,0,0
2389,0,1,"Bus_Doublendecker",[532765,751253,182432,382901,0,000000],[-1,694487,0,000000,[255,0,0],[0,211,0],[0,24,0],[0,0,0],[0,11.550000,1.700000,0,0,0
2386,0,1,"Bus_Doublendecker",[532763,847621,182444,138828,0,000000],[-1,405425,0,000000,[255,0,0],[0,211,0],[0,24,0],[0,0,0],[0,11.550000,1.700000,0,0,0
2710,0,1,"bike",[532758,865308,182464,208370,0,000000],[2,128142,0,000000,[255,128,0],[0,211,0],[0,24,0],[0,0,0],[0,1.445144,1.700000,0,0,0
2069,0,1,"car4",[532846,394679,182509,612143,0,000000],[0,459566,0,000000,[0,0,128],[0,211,0],[0,24,0],[0,0,0],[0,8.4.610003,1.700000,0,0,0
1977,0,1,"",[0,000000,0,000000,0,000000],[0,000000,0,000000],[0,0,0],[0,0,0],[0,0,0],[0,0,0],[-2,1.000000,1.000000,0,0,0
1949,0,1,"car3",[532736,362158,182603,452572,0,000000],[1,451747,0,000000,[0,0,128],[0,211,0],[0,24,0],[0,0,0],[0,8.4.610003,1.700000,0,0,0
1997,0,1,"",[0,000000,0,000000,0,000000],[0,000000,0,000000],[0,0,0],[0,0,0],[0,0,0],[0,0,0],[-2,1.000000,1.000000,0,0,0
2040,0,1,"",[0,000000,0,000000,0,000000],[0,000000,0,000000],[0,0,0],[0,0,0],[0,0,0],[0,0,0],[-2,1.000000,1.000000,0,0,0
2769,0,1,"486",[532770,174737,182367,735216,0,000000],[-1,478801,0,000000,[0,0,128],[0,211,0],[0,24,0],[0,0,0],[0,8.4.610003,1.700000,0,0,0
2381,0,1,"",[0,000000,0,000000,0,000000],[0,000000,0,000000],[0,0,0],[0,0,0],[0,0,0],[0,0,0],[-2,1.000000,1.000000,0,0,0
401283,2,0,"",[533208,421532,182621,522380,0,000000],[1,496206,0,000000,[0,0,1],[0,0,0],[0,0,0],[0,0,0],[0,1.000000,1.000000,0,0,0
2,2,0,"3/114",[533289,395565,182825,638025,0,000000],[2,773084,0,000000,[1,0,0],[0,0,0],[0,0,0],[0,0,0],[0,1.000000,1.000000,0,0,0
3,2,0,"3/113",[533205,482099,182834,240611,0,000000],[0,350894,0,000000,[1,0,0],[0,0,0],[0,0,0],[0,0,0],[0,1.000000,1.000000,0,0,0
3,2,0,"",[533610,181957,182032,433653,0,000000],[-0,904500,0,000000,[1,0,0],[0,0,0],[0,0,0],[0,0,0],[0,1.000000,1.000000,0,0,0
10,2,0,"",[533222,468972,182829,100720,0,000000],[1,581602,0,000000,[1,0,0],[0,0,0],[0,0,0],[0,0,0],[0,1.000000,1.000000,0,0,0
1040,0,1,"",[0,000000,0,000000,0,000000],[0,000000,0,000000],[0,0,0],[0,0,0],[0,0,0],[0,0,0],[-2,1.000000,1.000000,0,0,0
1005,0,1,"",[0,000000,0,000000,0,000000],[0,000000,0,000000],[0,0,0],[0,0,0],[0,0,0],[0,0,0],[-2,1.000000,1.000000,0,0,0
1240,0,1,"",[0,000000,0,000000,0,000000],[0,000000,0,000000],[0,0,0],[0,0,0],[0,0,0],[0,0,0],[-2,1.000000,1.000000,0,0,0
```

Figure 147: Animation file (*.ani.txt) example

- Vehicle Record files (*.fzp), which can be used for many purposes and whose content is completely user-specified (Figure I48). Specification of Vehicle Record files is found in the Direct Output tab in the Evaluation window (section B7.7). More information on the use of Vehicle Record files in emissions modelling can be found in Chapter C4 on Emissions Modelling.

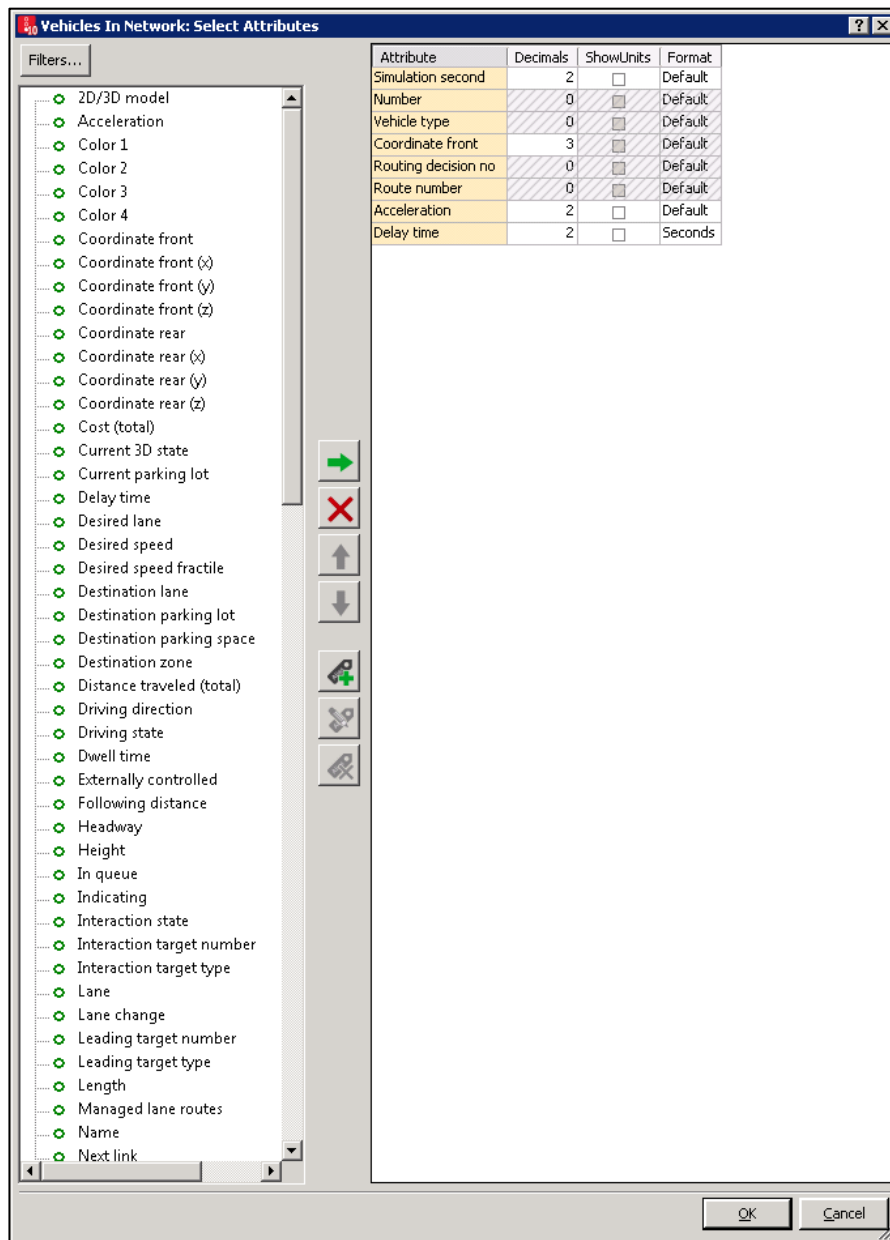

Figure I48: Vehicle record file (*.fzp) data selection



PART C – THE HEALTHY STREETS APPROACH

I Introduction to Part C



The Mayor's Transport Strategy (MTS)¹⁰⁶ sets out the Healthy Streets Approach¹⁰⁷ for active, inclusive and safer travel that aims to deliver improvements to walking and cycling environments in order to encourage more trips via these active travel modes. Enhancements to pedestrian and cycling facilities allow short to medium length journeys to be conducted actively and sustainably. A significant part of the environment for these modes is influenced by air quality, which will also be improved by people switching away from motor vehicles. In the MTS, it is estimated that 5 million car journeys per day in London could potentially be walked or cycled. One of the aims in the MTS is to transfer a sizeable proportion of these journeys to active travel modes.

In TfL Surface Transport, Network Management (NM), has a responsibility to support the assessment and delivery of a wide range of road transport schemes, which requires consideration of benefits and impacts for all road users. There has therefore been a focus in recent years on evolving modelling capabilities to ensure that scheme assessments better capture the relative benefits for both powered vehicles and non-powered road users. There has also been a growing emphasis on sustainable transport provision and associated planning considerations when delivering road schemes in London, prioritising improvements for both public transport

106 *Mayor's Transport Strategy*, Greater London Authority, March 2016

107 *Healthy Streets for London*, TfL, February 2017

and active travel modes including pedestrians and cycles. This part of the Modelling Guidelines covers modelling techniques to assist with:

- Cycling schemes and assessment of cycle infrastructure provision (see Chapter **C2** on **Cyclist Modelling**);
- Walking schemes and assessment of pedestrian infrastructure provision (see Chapter **C3** on **Pedestrian Modelling**); and
- Emissions studies undertaken as part of road network scheme assessment (see Chapter **C4** on **Emissions Modelling**).

For illustration, real-world examples are presented relating to modelling projects covering each of these areas. Each case study is briefly outlined alongside the modelling tools used for assessment, with the benefits and limitations explored. The approach taken for each project is contrasted against previous and existing methodologies in order to highlight the improvements and set out aims for the future.

The remainder of each chapter looks in more detail at the processes involved in the different types of modelling, referring to relevant software packages where appropriate.

Before reading this section, it should be considered a pre-requisite to be familiar with the content contained within Chapter **B2** on **Modelling Principles**. Further technical detail on specific modelling software covered within **Part B** should also be consulted as necessary.

Some of the modelling advice presented within this part of the Guidelines, particularly in the **Cyclist Modelling** and **Emissions Modelling** chapters, represents initial guidance based on TfL's experience to date and continues to be developed. TfL welcomes discussion of alternative methods used in the wider industry, is eager to engage on advancing modelling capability and continues to collaborate with software suppliers on these topics.

2 Cyclist Modelling



2.1 Introduction

The number of cyclists in London is growing, especially during peak periods. For example, in the Congestion Charging Zone it has reached 16% of total vehicle flow¹⁰⁸. As growth in cycling is integral to the Mayor's vision for increasing the use of sustainable modes in London, it is important to consider the role and impact of cyclists in the network.

In recent years there has been progress towards ensuring the provision of a more balanced transport impact assessment for all schemes, particularly for those with an emphasis on Healthy Streets. One result of this change in focus was to highlight that established modelling approaches using existing tools were not entirely suitable, as is outlined in more detail in the case study below. TfL has evolved existing road scheme assessment techniques so that they are more appropriate for modal interaction and ultimately more reflective of the modern road network.

This chapter explores the updated traffic modelling approach when applied to a cycle infrastructure scheme assessment. It considers currently available modelling tools and best practice methodology, within existing constraints and limitations, focusing on traffic modelling software that has been covered in **Part B**. The aim is to provide a point of reference to those

108 Harryman, M., Traffic Note 3 – TfL Cordon & Screenline Surveys 1971-2018, Transport for London, 2019

considering Healthy Streets schemes that specifically focus on cycling provision enhancements, as well as traffic schemes that incorporate cycle facilities into the wider scope of the proposals.

Any effects of a proposed scheme on cycling, and any possible growth in cycle demand, need to be carefully considered before selecting the most appropriate software for a modelling project. Particularly in inner London, cyclists should typically be considered in any modelling work unless there is reasonable justification to exclude them.

The cyclist modelling advice presented within this chapter represents initial guidance based on TfL's experience to date and continues to be developed. TfL welcomes discussion of alternative methods used in the wider industry, is eager to engage on advancing cyclist modelling capability and continues to collaborate with software suppliers on this topic.

2.1.1 Case Study

This case study has been included to illustrate the difficulties in modelling cyclists using previous approaches and techniques and to highlight the improvements that have been made.

As part of the Mayor's Cycling Vision¹⁰⁹, a segregated East-West Cycle Route (EWCR), which incorporated the existing Cycle Superhighway 3 (CS3, the eastern end of the route, opened in 2010), was proposed to run along the City Route corridor from Barking in east London to Wood Lane in the west. One of the proposed routes through the central section is shown in **Figure 149**.

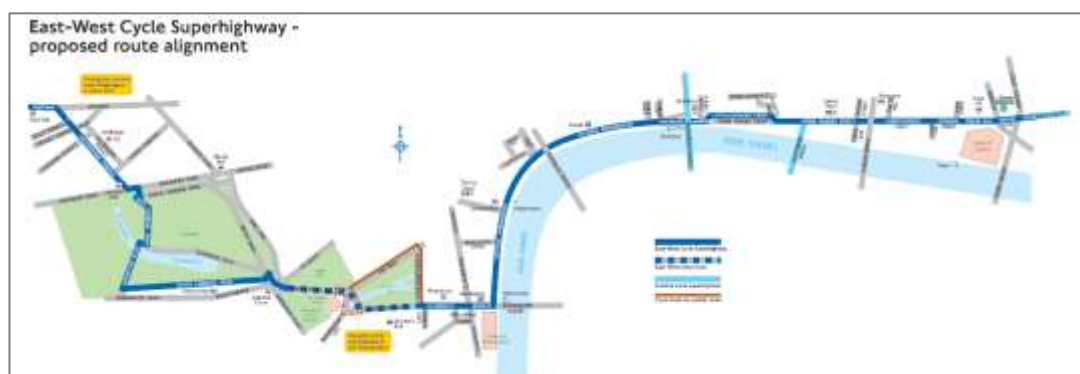

Figure 149: East-West Cycle Superhighway proposed route alignment

¹⁰⁹ The Mayor's Vision for Cycling in London – An Olympic Legacy for all Londoners, Greater London Authority, March 2013

At the time of publishing, a long section of the route has been completed, from Barking to Lancaster Gate. A large part of it is on TfL roads and all of it needed to be modelled. Like many of the latest cycle schemes planned or delivered in London, a large proportion of this route is physically segregated in order to provide a safer environment for cyclists. Dedicated infrastructure is implemented at signalised junctions to provide a safer, smoother transition for those using the route.

Prior to Cycle Superhighways, cyclists were rarely explicitly modelled, either in deterministic or microsimulation modelling (section [C2.4.1](#)). When they were included it was as a capacity constraint in deterministic modelling or, in microsimulation, as an aesthetic addition which did not interact with other vehicles. This was due to difficulty in modelling their behaviour accurately but, since they were often low in number, it was not a significant problem. EWCR represented a number of reasons these approaches were no longer sufficient:

- EWCR was a high-profile scheme along a highly visible part of the TLRN with some vocal opponents. It was necessary to carry out a thorough investigation into the potential impacts of the scheme in order to support the business case;
- Since the scheme was specifically intended for the benefit of cyclists it was important to produce modelling results, such as delay and journey times, for cyclists as well as other modes of transport;
- The scheme was predicted to attract high numbers of cyclists so it was important to give some confidence that the new facilities would have sufficient capacity;
- The aim was to provide complete segregation for cyclists wherever possible, which required separate phasing at signalised junctions and led to more complicated methods of control than before ([Figure 150](#)); and
- Any visualisations of the scheme which could be used to show stakeholders how it would operate would need to include cyclists.

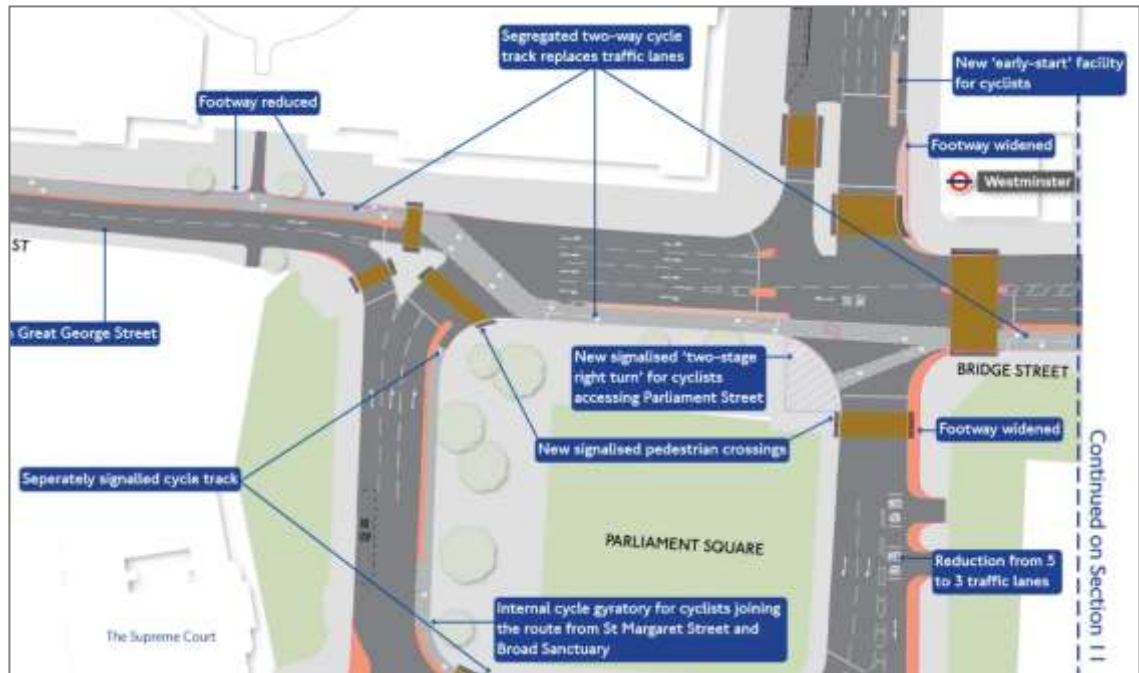

Figure 150: Proposed changes at Parliament Square for EWCR

In order to facilitate this work, Modelling & Visualisation (M&V) liaised with Network Performance Delivery (NPD) to review performance data gathered from cycle infrastructure based on on-street observations across London. This led to desktop studies with a focus on better application of techniques and behavioural models using existing modelling tools. Development has continued in recent years with a succession of similar schemes employing the modelling tools that are required for Three Stage Modelling (sections [A3.5](#) and [B2.1.4](#)) of cycle infrastructure delivery projects. It also includes a requirement to produce deterministic models to derive signal timings and understand the capacity constraints of the new infrastructure.

The key objectives of the revised methodology are:

- To realistically model cyclist capacities along varying widths of segregated cycle lanes (modelling cyclist saturation flow);
- To model cyclist behaviour in a manner suitable for presentation; and
- To minimise the modelling effort by categorising behaviour scenarios.

Attempts have also been made to improve the modelling of cyclists on mixed traffic links. Rather than focusing on cyclists' impact on traffic, assessment of cycle progression and performance relative to other modes in a shared road environment is key. In order for cyclists to be explicitly included in the modelling, improved techniques were required in the following areas:

- Deriving capacities and signal timings in deterministic modelling; and
- Lateral behaviour in microsimulation modelling, including cyclist interactions with general traffic as well as how they behave in segregated lanes.

All of this work led to a successful opening of the central section of EWCR, from Tower Hill to Parliament Square, in April 2016 (**Figure 151**). The usage of the route increased from an average of 22,500km cycled per day in 2014 to a daily average of 35,000km in 2016¹¹⁰.



Figure 151: Cyclists on EWCR

2.2 Research

This section includes research on cycling that has been carried out or commissioned by TfL, and which provides the basis for cyclist modelling work.

2.2.1 TfL Research

The following research was conducted within TfL by M&V.

2.2.1.1 Cyclist-Vehicle Interaction at ASLs^{III}

Research was carried out, in preparation for the introduction of Cycle Superhighways in 2010, to better understand the impact of cyclists at junction stoplines with ASLs on the discharge rate of motorised vehicles. Cyclists moving away from an ASL on a green signal can delay vehicular traffic for a short period of time, effectively reducing the vehicle discharge rate and causing Underutilised Green Time (UGT).

The study concluded that although the number of cyclists waiting in the ASL did not entirely account for the time taken for cyclists to clear – junction geometry also played a significant role – there was enough evidence to introduce a figure of two seconds UGT per green period when the number of cyclists exceeded 470 per hour. This figure is only used in deterministic modelling with high volumes of cyclists, and when it is used cyclists should not be included in the modelled flows. This research was carried out on both one- and two-lane approaches.

2.2.1.2 Cyclist Saturation Flows at Segregated Stoplines^{II2}

Observations were made of cyclist discharge rates and behaviour at five segregated stoplines on existing Cycle Superhighways in 2013, and further updated in 2017 to include two busier stoplines. The method used was similar to that used when collecting vehicular saturation flows. Analysis of these observations led to the following conclusions:

- The discharge rate of segregated cyclists is related to the lane width and the number of queues that can form;

III Hooper, D., Green, J., Farren, R., Hook, C., Cyclist and Vehicle Interaction Study – Preliminary research into the relationship between cyclist traffic and vehicular traffic at Traffic Signals, Transport for London, September 2009

II2 Bulmer, S., Investigation into Cyclist Saturation Flows, Transport for London, May 2013

- On narrower lanes of around 1m, where only one queue can form, a reasonable saturation flow is around one cyclist per second;
- Once the lane is wide enough for two queues to form (between 1 and 2 metres), the discharge rate is also related to the volume of cyclists. The higher the cyclist volumes, the more use is made of the extra queuing width, and so the higher the discharge rate; and
- A good rule of thumb is that for fully saturated approaches with no unusual geometry, for example a straight, flat road, a stopline can discharge a maximum of one cyclist per second for every metre of lane width, as is shown in **Table 14**.

Table 14: Observed discharge rates of cyclists at segregated stoplines

Width of Cycle Lane (metres)	Cyclists per second	Saturation Flow (PCU/hr)
1	1	720
1.5	1.33 – 1.5	960 – 1080
2	1.67 – 2	1200 – 1440

2.2.2 TRL Research

TRL has performed a number of research projects on behalf of TfL. This section outlines the results of two studies relevant to cyclist modelling.

2.2.2.1 Cycle Behaviour and Dispersion Research

TfL commissioned research from TRL¹¹³, which looked at cyclist behaviour at eight junctions across central London. It investigated the questions of dispersion and overtaking on links and at junctions. It is dated 2014-2015, which is towards the beginning of the relatively recent rise in cyclist numbers and should be viewed in that light. The key points to take away from this research, from a modelling point of view, are:

113 Crabtree, M., TfL cycle behaviour and dispersion research, Pilot study – Items to measure from video captured 12th and 13th August 2014, Transport Research Laboratory, September 2014
 Emmerson, P., TfL cycle behaviour and dispersion research, Pilot study – Initial analysis, Transport Research Laboratory, October 2014
 Emmerson, P., Crabtree, M., TfL cycle behaviour and dispersion research, Main study - Analysis, Transport Research Laboratory, April 2015

- Cyclist speeds are higher in the AM than inter-peak or PM, as shown in **Table 15** below:

Table 15: TRL-measured cycle speeds¹¹³

Period	Speed (m/s)	Standard Error
AM	6.64	0.05
IP	5.20	0.09
PM	4.05	0.1

- Cyclists on cycle hire bikes were, on average, 1.1m/s slower than other cyclists.
- Potential cyclist dispersion factors were derived using three different estimation methods; however, two of the three derived factors indicate that cyclists disperse less than cars, which seems counterintuitive due to the high variability in cyclist speeds and the relative ease with which they can overtake. More research with higher numbers of cyclists is therefore considered to be needed on cyclist dispersion. Until this has been carried out, existing dispersion factors for vehicles should be used as there is insufficient evidence to alter them.

2.2.2.2 Impact of Cyclists on Saturation Flows

In 2012, TfL commissioned TRL to investigate discharge at traffic signals¹¹⁴ in the presence of cyclists. The key relevant findings were:

- At stoplines with ASLs, the PCU value of cyclists was estimated at about half that for stoplines without ASLs. The range of values for different scenarios fell between 0.05 for a Cycle Superhighway with an ASL and 0.8 for no ASL; and
- As cyclist volumes increased, the PCU value of cyclists decreased.

The report acknowledges that more research is required to investigate and confirm these findings, however they can be borne in mind when modelling cyclists.

114 Emmerson, P, Crabtree, M, Gibson, H, The estimation of saturation flows at traffic lights in London, and the impact of cyclists on saturation flows, Transport Research Laboratory, December 2012

2.2.3 Cynemon

Cynemon is a strategic cycling model, built by TfL City Planning Strategic Analysis on the Cube platform, which estimates cyclist routes, flows and journey times at a strategic level across London for scheme and policy appraisal.

Demand data is taken from a number of sources, including the London Travel Demand Survey, Census, cycle hire OD data, and various other surveys, and put into a gravity model¹¹⁵. The network comes from the Integrated Transport Network (ITN) layer from Ordnance Survey's MasterMap, since superseded by the Ordnance Survey MasterMap Highways Network layer, with added TfL GIS layers. A route choice algorithm was developed from observed GPS data collected through an online survey and mobile phone application. Observed routes were used to determine the value that cyclists place on road type, cycle infrastructure, bus lanes, traffic volume and gradients when choosing their routes.

This model can be used to assess options and appraise schemes that have a strategic impact on cycling. Methodologies for transferring data into local or microsimulation models are currently being developed. For further information, contact Cynemon@tfl.gov.uk.

115 A gravity model uses the relative sizes and distance between two places to predict the amount of flow between them. For example, people are more likely to travel further to go to a supermarket than a corner shop.

2.3 Data Collection

Collecting site data on cycling can be challenging, however cyclist behaviour can be key to understanding the operation of a junction or facility. On-site observation of existing conditions and cyclist behaviour is essential for the development of accurate models of current situations and, where possible, similar facilities should be observed to inform proposed designs.

It is important to note that at different times of day or days of the week, different types of cyclists are likely to use the same facilities. For example, data collection during weekday peak periods will likely result in a high proportion of commuter cyclists, whereas weekend observations will include larger numbers of cyclists riding for leisure. This will have an impact on routing behaviour and cyclist speeds. In addition, seasonality causes large changes in the number of cyclists observed using the network, as can be seen in **Figure 152**.

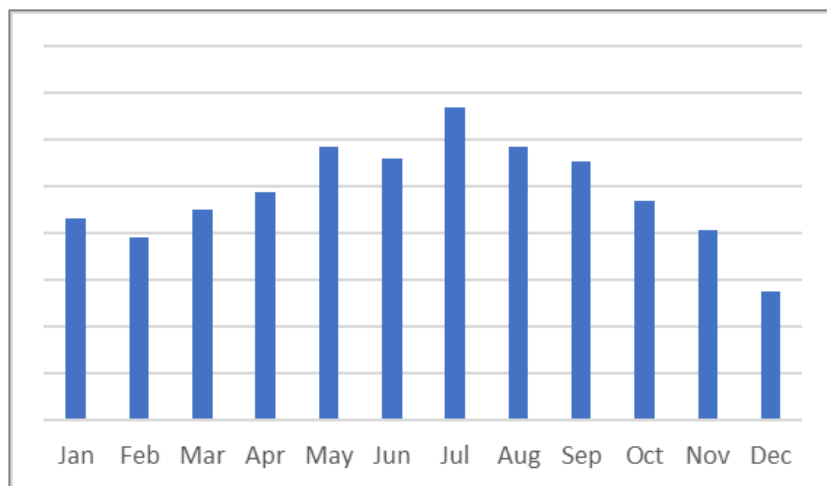

Figure 152: Cyclist trips throughout 2019 ¹¹⁶

Conducting surveys in the colder months could lead to a significant underestimation of cyclist volumes and have an impact on the viability of design proposals.

Both general traffic and cyclists should be considered when deciding on an appropriate time to carry out surveys. A neutral month should be chosen if possible, however adjustments can be made to cyclist flows if required.



Figure 153: Cyclist not impeding other traffic

When collecting saturation flows, Degrees of Saturation (DoS) and queue lengths for general traffic, a decision must be made as to whether to include cyclists. It is important that this decision is consistent across all of these measurements.

As a rule, cyclists that queue separately to the side of the traffic and discharge without impeding it should not be included in these measurements (**Figure 153**). Any cyclists that sit in the traffic queue should be measured, traditionally with a PCU value of 0.2 (see section **B2.3.4.1.1** for PCU table).

2.3.1 Flows and Routing

The most straightforward data collection exercise is manual classified counts, in which the numbers of vehicles, including cyclists, are counted for all movements through a junction. This should be sufficient for localised models, which represent the design of a single junction or proposed facility. If cyclist counts are collected at multiple sites it is very likely that flows will not be balanced between sites, as cyclists can start and end their journeys at almost any point in the network. Cycle parks and stands should therefore be included in counts as they represent significant sources and destinations for cyclists.

In some cases, where a high level of detail is needed, it may be necessary to divide cyclists into cycle hire and non-cycle hire. This is the one category of cyclists that is easy to distinguish and therefore possible to count. Also, as mentioned in section [C2.2.2.1](#), cycle hire bikes are generally slower than normal bikes, so this added level of detail may be useful. If cycle hire bikes were not included in the original counts, then spot counts can be carried out to determine their proportion. Alternatively, in central London, the average proportion of cyclists using cycle hire bikes was found to be 13% in 2017. Updated figures, in some cases with site-by-site breakdowns, can be obtained from ModellingData@tfl.gov.uk. Clearly, this distinction can only be made within the cycle hire area¹¹⁷.

Some schemes may require a more detailed understanding of cyclist origin and destination points in order to model cyclist routes. Since cyclists are not uniquely identifiable in the same way as other vehicles with registration plates, postal surveys may be required to identify key routes. After postal surveys, further assumptions would be required to obtain a full Origin-Destination (OD) matrix of cyclist movements, using matrix estimation for example, as it is impractical to collect data for all possible origins and destinations. Alternatively, there is the potential to use Cynemon for determining cyclist routing (section [2.2.3](#)).

117 <https://tfl.gov.uk/modes/cycling/santander-cycles/find-a-docking-station>

2.3.2 Journey Times

When considering journey time validation, one difficulty is acquiring the data to validate against. In recent years, TfL has started to use GPS data from social fitness networks for this purpose. The cycling data is aggregated and anonymised before matching the GPS tracks to OS MasterMap Highways Network edges (edges are sections of the network between junctions).

Data may be collected for each edge each hour per direction, consisting of the number of cyclists and the median average time it took cyclists to travel the length of the edge. These can be further aggregated to provide average travel times and counts by edge and hour for each month as well as summing edges together between junctions. Median average travel times are used as they are less sensitive to outliers. This is important because it is possible for users to accidentally be tracking a cycle trip while actually using another type of vehicle or walking.

Additional types of cyclist data that are important for modelling are speed and acceleration / deceleration rates. This data is needed if journey time analysis is required or there is an interest in progressing cyclists through a series of facilities with minimal delay and stops.

2.4 Cyclist Modelling

Cyclist modelling lacks the industry-wide research and experience that has built up over many years with respect to general traffic. This is partly because until relatively recently cyclist numbers have been quite low, and partly because modelling cyclists is more difficult than for general traffic.

Cyclist behaviour is considerably less predictable than for other vehicles, as they have a large variety of potential (legal and illegal) routing choices. These include actions such as red light violation¹¹⁸ and cycling on the pavement, as well as cycle-only routes, segregated lanes and filtering through traffic. Cyclists also vary widely in their speed, ability and assertiveness. Any traffic model involves simplification and this is particularly the case when modelling cyclists due to the wide variety of observed behaviours. It can also be challenging to capture suitably detailed data for the purpose of calibration and validation. It is important to observe cyclists' behaviour in the area of interest and capture the relevant features.

In addition, it is important to take account of the behavioural responses of all road users to proposed designs, for example, how different modes react to lane markings on the approach and through junctions. For this reason, microsimulation is often the most appropriate assessment tool. Capacity constraints of cycle lanes should be modelled accurately, including situations where cyclist demand may exceed the capacity.

Models of proposed designs should generally assume full compliance with signals and lanes, as proposed infrastructure should be designed to cater for all demand. In order to provide a fair comparison, this means that full compliance should also generally be modelled in Base scenarios, even where this is not the case on street. Further advice should be sought in the case where there is a high degree of non-compliance that is affecting validation. A possible exception in the case of Proposed modelling would be if it was anticipated that new infrastructure would increase compliance levels. This would have to be agreed with NP in advance, in accordance with the model purpose, and detailed records made of the nature and level of non-compliant behaviour.

118 Road Network Performance & Research Team, RNPR Traffic Note 8 – Proportion of Cyclists Who Violate Red Lights in London, Transport for London, June 2007

On street, cycling can be split into two categories:

- **Segregated** – cyclists occupy a dedicated cycle lane and have no interaction with other traffic; and
- **Non-segregated** – cyclists influence, and are influenced by, other vehicles as they share road space.

When modelling cyclists, the recommended approach depends on the nature of the modelling software being used, typically deterministic or microsimulation (see Chapter **A5** on **Which Traffic Modelling Software? Why?**).

This chapter therefore considers the modelling methodologies for the following four groups:

- Deterministic segregated cyclists;
- Deterministic non-segregated cyclists;
- Microsimulation segregated cyclists; and
- Microsimulation non-segregated cyclists.

2.4.1 Deterministic or Microsimulation?

It is often the case that factors other than cyclists determine which type of modelling will be used, however, cyclists should always be included in the decision-making process. Points to consider are:

- **Interaction** – the more interaction cyclists have with other traffic, the more useful microsimulation becomes in generating realistic modelling;
- **Volume** – higher cyclist numbers are likely to need microsimulation as they are more likely to interact with general traffic or require special consideration;
- **Objectives** – if the scheme has specific cycling objectives then microsimulation is likely to be required;
- **Results** – if journey time comparison is necessary then microsimulation should be used. Journey times are difficult to validate successfully, even in microsimulation models (sections **C2.3.2** and **C2.6.7**), so deterministic modelled journey times should be treated with caution; and
- **Outputs** – high-profile schemes are likely to require some form of animated visualisation of the modelling results.

2.5 Deterministic Modelling

Deterministic traffic modelling software can only reflect the aggregate impact of a scheme by directly modifying parameters that influence junction performance, such as saturation flows and signal timings.

Traditionally, cyclists were not always explicitly included in deterministic traffic models due to difficulty in modelling their queuing behaviour accurately, and since they were often low in number. As described in section [C2.1.1](#), the significant growth in cyclist numbers in London over recent years, including the introduction of Cycle Superhighways and separately phased cycle lanes, means that approach is no longer viable in many locations.

2.5.1 Segregated Cyclists

For segregated cycle lanes, measuring saturation flows can be carried out in a similar manner to that for motorised vehicles. For this purpose, cyclists can generally be treated as a single vehicle class although measurements with a particularly slow-moving cyclist may need to be omitted from counts, as a motorised vehicle measurement would be if, for example, a vehicle stalled. This may need to be revisited if electric scooters become more prevalent or in particular areas with large numbers of cargo bikes or cycle rickshaws. It is rare that cyclists will suffer from junction exit-blocking as motorised vehicles do, however, if cyclists are regularly impeded by other vehicles then this should be captured using UGT.

The methodology used when modelling the proposed introduction of Cycle Superhighways has been to fix the green time for the cycle lane, based on the proposed lane width and the predicted number of cyclists, and then to optimise the other stages around it. The green times used in these calculations come from the following formula:

$$\text{Green time} = \frac{\text{Predicted flow}}{\left(\text{Cyclists per second} * \left(\frac{3600}{\text{Cycle time}} \right) \right)}$$

The number of cyclists per second in the formula is derived from the lane width, using the observations from existing Cycle Superhighways detailed in section [C2.2.1.2](#). The cyclists per second value can also be adjusted to take account of any site-specific junction geometry. Since the observations were taken in ideal conditions with an average of 30 cyclists per green period, the value of one cyclist per second for every metre of lane width in a single direction should be taken as a maximum.

Without fully calibrated and validated cyclist flows in a Base model, as will be the case for new segregated cycle lanes, this method of fixing green times in Proposed models is the recommended methodology. For example, a 2m lane can discharge two cyclists per second in ideal conditions. If the predicted flow is 900 cyclists per hour at a junction with a 96 second cycle time, using the formula above gives a green time of 12 seconds. This should be calibrated in the model using an appropriate fixed stage length before any optimisation is carried out. The application of this methodology in a deterministic model is shown in [Figure 156](#).

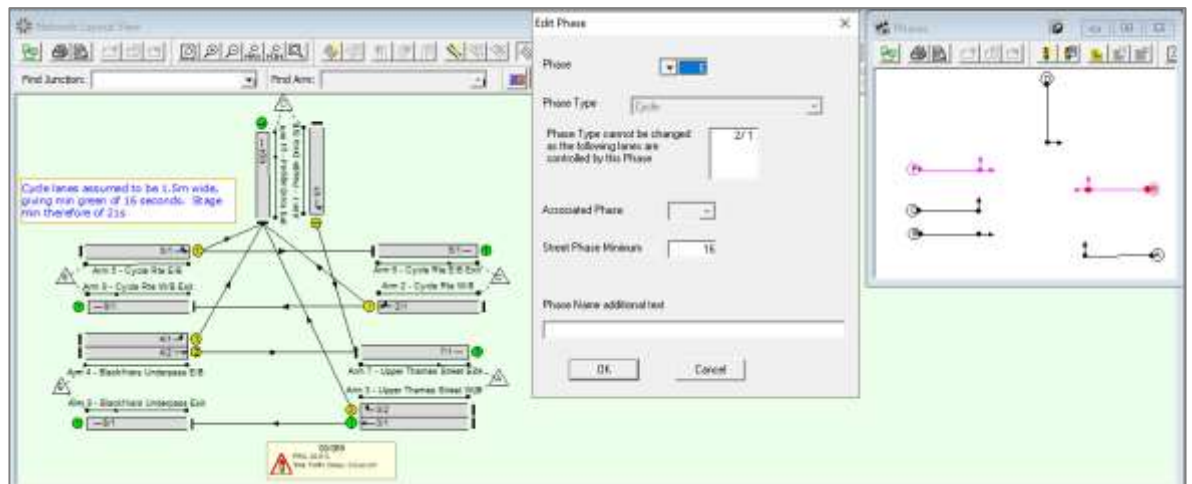

Figure 154: Modelling of a segregated cycle lane in a deterministic model, with fixed green times based on cycle lane widths

Since there is a growing need to optimise offsets for cyclists as well as general traffic, it is recommended that cyclist cruise times are measured in key locations.

2.5.2 Non-Segregated Cyclists

The key point to consider when modelling cyclists in mixed-traffic conditions is to observe the impact cyclists have on traffic capacity and try to replicate it. If cyclists entirely queue and discharge beside vehicles without impeding them, at all junctions in the model, they can be excluded without affecting modelled capacity. Including cyclists as additional PCUs serves no useful purpose when the aim is either to validate a Base model or to optimise a Proposal, as it adds unrealistic PCUs to the vertical queue model, making queues appear longer than they really are.

If any cyclists queue with traffic and occupy space that would otherwise be taken up by vehicles, at any stopline, then these should be included in the model as part of the flow, saturation flow and DoS measurements. An appropriate PCU value should be used in these cases. A value of 0.2 is

traditionally used (section [B2.3.4.1.1](#)), although findings from the TRL research in section [C2.2.2.2](#) may be relevant if issues are encountered.

If cyclists are not being included as PCUs, ideally a vehicular saturation flow would be measured with as few cyclists present as possible. This means that any increase in cyclist numbers and interaction can be accounted for using the UGT method of collecting DoS. The UGT can usually be modelled using negative bonus greens, or by adding a dummy stage which does not include the relevant phase in order to decrease the green time, where bonus greens are unavailable. Adjusting phase delays and intergreens is a possibility but is not recommended as it interferes with the audited controller configuration. Care must be taken when using these methods in Base models that they are transferred appropriately to any Proposed models.

As described in section [C2.2.1.1](#), when an ASL is present or it is anticipated that cyclists will behave as if there is, site observations have shown that the impact of cyclists on vehicular traffic amounts to 2 seconds of UGT per green period when the number of cyclists exceeds 470 cyclists per hour¹¹⁹. This can be applied in Proposed models where the proposal includes a new ASL and there are no Base measurements to carry across. As above, it can usually be modelled with a 2-second negative bonus green, or by adding a dummy stage which does not include the relevant phase in order to decrease the green time.

If it is difficult to distinguish whether cyclists queue in the same manner as vehicles, cyclists significantly interfere with vehicular traffic or the impact of the cyclists is unpredictable from one cycle to the next, then it is possible that deterministic modelling is not suitable and that microsimulation should be considered.

119 Hooper, D., Green, J., Farren, R., Hook, C., *Cyclist and Vehicle Interaction Study*, Transport for London, August 2009

2.6 Microsimulation Modelling

Microsimulation traffic modelling software is capable of modelling general cyclist behaviour and can highlight potential design issues that other tools cannot. As with any microsimulation modelling, the key consideration is to replicate observed behaviour to the level of accuracy necessary for the modelling purpose. Fundamental aspects to consider when modelling cyclist behaviour are:

- Cyclist trajectories;
- Lane positioning;
- Lateral clearances;
- Queuing formations; and
- Performance (speeds and acceleration profiles).

All of the above points need to be modelled accurately if the inclusion of cyclists in a traffic model is to yield reliable modelling outputs and inform the design process in a constructive manner. Poorly modelled cyclist behaviour can be detrimental to the analysis of model outputs and reflect badly in the evaluation of otherwise viable schemes. Modelling cyclists, whether segregated or not, requires the modelling of overtaking behaviour so the chosen modelling software should support this.

The parameters M&V developed in order to produce modelling for the East-West Cycle Route¹²⁰ have been incorporated and further refined into the latest TfL Vissim Template (section **B7.1.2**). This section includes details of these parameters along with advice on how to use them. While the parameter names are specific to Vissim, the techniques can be applied in other microsimulation software where equivalent parameters are available.

2.6.1 Links and Behaviour Parameters

The link and connector network structure for cyclists can be modelled using the four main behaviour types defined in the TfL Vissim Template (section **B7.1.2**):

- Segregated links;
- Segregated stopline links;
- Non-segregated (mixed) links; and

¹²⁰ Green, J., Cyclist Modelling Briefing Note East-West Cycle Super Highway, Transport for London, April 2014

- Non-segregated (mixed) stopline links with an ASL, or equivalent behaviour, present.

Lane and vehicle widths are particularly important when modelling cyclists, as lateral behaviour, such as vehicles overtaking in the same lane, plays a significant role in their movements and interactions.

2.6.1.1 Segregated Links

In order to prevent unrealistic two-way overtaking manoeuvres, segregated links should have a width of 0.25m less than the design width so that two-way paths have a 0.5m clearance between them¹²¹. As is shown in **Figure 155**, the gap also helps cyclists maintain the safe separation that they would on street.

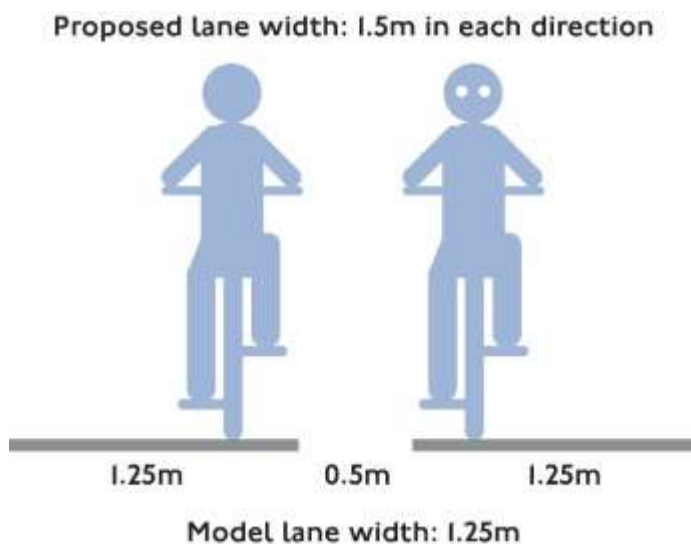

Figure 155: Lane widths showing 0.5m clearance between opposite directions

Segregated stopline links should be modelled using the entire design width specified. As a starting point, they should begin approximately 8m before the stopline and terminate approximately 8m after the stopline. However, when the exit of a stopline link is connected to a segregated link of lesser width some bunching and snagging can occur, due to cyclists not having dispersed adequately and alternative lateral behaviour parameters taking effect. It may therefore be necessary to increase the length of the segregated stopline link beyond the stopline to reduce this snagging. In addition, it is also helpful to reduce the link widths following a segregated stopline link in increments to further reduce snagging. In **Figure 156**, with cyclists travelling from left to right, the width of the cycle lane is 1.5m

which increases to 2m at the stopline (stopline behaviour applied) and tapers back to 1.5m via a 1.75m Link to help cyclists disperse smoothly.



Figure 156: Stopline location and decreasing link widths

2.6.1.2 Non-Segregated Links

For junction turns it is often beneficial to provide cyclists with their own connectors, separate from other vehicles, as cyclists generally take different paths through turns to motorised vehicles. This is one of the most challenging areas of modelling cyclists and a significant amount of testing and calibration is required. Conversely, ahead movements can work better using one connector for all traffic, particularly if cyclists delay other traffic discharging from the stopline.

The recommended starting point for modelling the different cycle facilities provided in mixed traffic conditions are summarised below:

- **Mandatory cycle lane, separated from traffic with wands (semi-segregated)** – Due to the physical separation between cyclists and traffic, these cycle lanes should be modelled using the segregated link behaviours (section [C2.6.1.1](#));
- **Mandatory cycle lane, with little or no incursion** – it is recommended that a separate cycle only lane is modelled, with the on-street width of the mandatory cycle lane reflected. The ‘observe adjacent lane(s)’ parameter should be applied for all vehicle types;
- **Advisory cycle lane, with little or no incursion** – these should be modelled in the same way as a mandatory cycle lane with little or no incursion;
- **Advisory cycle lane, with incursion or narrow width** – it is recommended that the carriageway is modelled as a single wide lane with non-segregated (mixed) traffic behaviours; and
- **No cycle lane** - it is recommended that the carriageway is modelled as a single wide lane with non-segregated (mixed) traffic behaviours.

For further information on how to model the different cycling facilities listed above, please refer to the TfL Vissim Template guidance documentation (section [B7.1.2](#)).

Where cycle lanes have been provided on a shared link, the traffic lane adjacent to the cycle lane should be open to cyclists to allow realistic overtaking behaviour, while any other offside lanes should be closed unless in the vicinity of right turns. The starting point to allow lane changing for right turns should be carefully calibrated from site observations.

Particular consideration should be given to links where cyclists can overtake buses at bus stops. The model should be configured so that buses stop on the left-hand side of the link and cyclists can overtake on the offside only. Link widths and lateral behaviours should be set up so that vehicles can only overtake the bus if they are able to on street, for example, it may be the case that cyclists and cars can overtake where lorries cannot. **Figure 157** shows a cyclist completing an overtaking manoeuvre and a car attempting to start one. The lane width has been increased to allow these manoeuvres to happen as they do on street. A behaviour type has been included in the TfL Vissim Template (**B7.1.2**) to assist with modelling cyclists at bus stops.

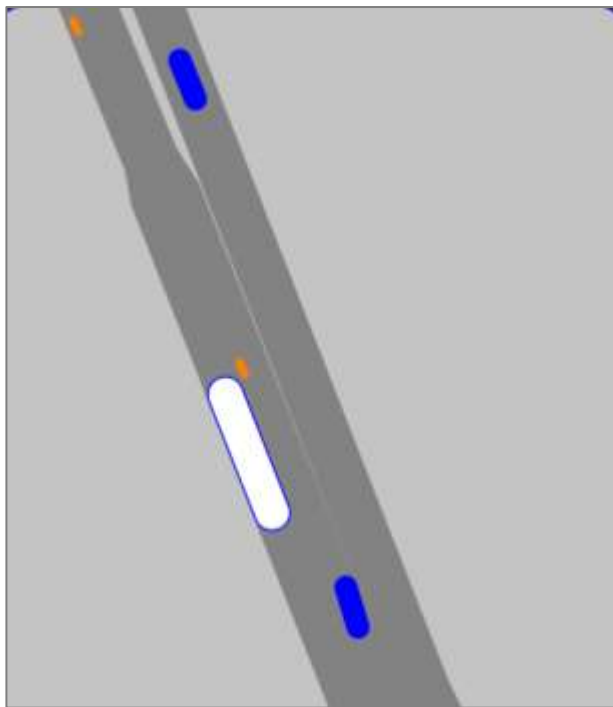

Figure 157: Cyclist overtaking a bus at a bus stop

2.6.1.3 General

Cyclist-cyclist driving behaviour can be a challenge to model correctly in high-volume cyclist situations. Priority rules for cyclist-cyclist conflicts have been seen to work effectively by adjusting the typical Min Gap Times and Min Headways values used for general traffic conflicts. The calibration starting point for these values are demonstrated in the TfL Vissim Template (section [B7.1.2](#)) and supporting guidance documentation.

Where cyclists make turns an appropriate reduced speed distribution should be used and the Connector's Desired Direction set to All, Right or Left accordingly. This causes cyclists (and vehicles in general) to adopt the correct lane position before turning and prevents blocking of other movements. It should be noted that use of the Desired Direction parameter may cause unrealistic single file queues, so it could subsequently be necessary to set it back to All or adjust the positioning of the connector in relation to the link.

Since a large part of cyclist modelling is dependent on observation, regular reviews of the models should be performed in 3D mode to check that behaviour looks acceptable. A general principle of modelling cyclist behaviour can be stated, "if it looks wrong then it probably is"¹²². If this is the case, then further adjustments will need to be made. Feedback on unusual situations is welcome and should be sent to TfLModellingGuidelines@tfl.gov.uk.

2.6.2 Composition

For cycling-specific schemes in central London where a high level of detail is required, it may be necessary to split cyclists into general and cycle hire bikes. See section [C2.3](#) for further details.

2.6.3 Speed and Acceleration

The TRL research discussed in section [C2.2.2](#) suggests that the main influencing factors on cycle speeds are time of day, and whether the cyclist is using a cycle hire bike or not. Speed distributions have been included in the TfL Vissim Template files (section [B7.1.2](#)) to cover these possibilities.

The speed distributions in the TfL Vissim Template have been based on observed data; however, a limited number of sites with differing characteristics were involved so they should only be considered as a

¹²² Green, J., Cyclist Modelling Briefing Note East-West Cycle Super Highway, Transport for London, April 2014

starting point. Adjustments may be required depending on turning movements, gradients or other factors.

Similarly, preliminary acceleration profiles have been added to the Template.

2.6.4 Routes

As with general traffic (section [B7.4.4](#)), it is preferable to use end-to-end routing for cyclists if possible. Depending on the proposed scheme, simply implementing turning counts as local routes through a junction in a microsimulation model can cause problems when moving to the proposed design, for example if junction layouts have changed or movements banned.

A simple matrix estimation exercise can be used to generate routes from turning counts if no other information is available. Caution should be used, however, as this can generate unrealistically long routes in larger models and can lead to some inappropriate routing.

This is one possible use for Cynemon (section [C2.2.3](#)), and methods of using Cynemon routing data in microsimulation models are being explored at the time of publishing.

2.6.5 Stopline Capacity for Segregated Cyclists

As is the case for deterministic modelling, cyclists should be calibrated to achieve the stopline capacity derived from the research outlined in section [C2.2.1.2](#). The TfL Vissim Template (section [B7.1.2](#)) includes parameters for segregated link stoplines, which can be used as a starting point ([Figure 158](#)).

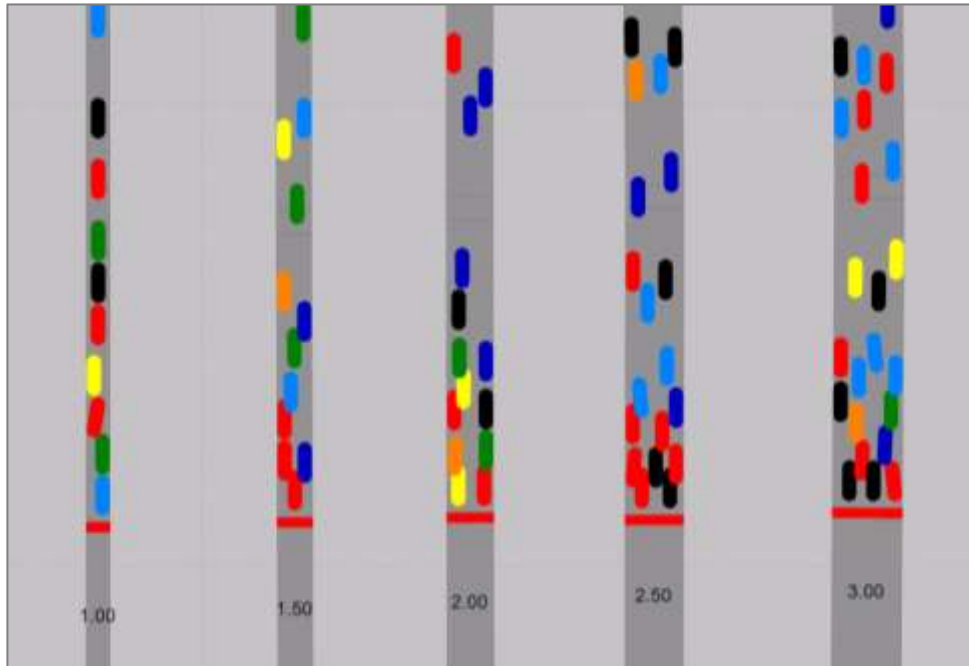

Figure 158: Vissim cyclists forming queues at various lane widths

If the link is at, or intended to be at, capacity, then the stopline discharge rate is achieved if the cyclists use all the green time but no queues form between green periods. Otherwise, the discharge rate can be checked manually against the required capacity by observing the model. As indicated in section [C2.6.1.3](#), it is good practice to watch each stopline in any case, as this will help identify any other modelling issues.

2.6.6 Stopline Capacity for Non-Segregated Cyclists

Modelling cyclists in mixed traffic conditions is often more challenging than for segregated situations, as there is more interaction at the stopline. It can be particularly difficult to measure and calibrate saturation flows at these stoplines. An ideal methodology would be:

- Measure the traffic saturation flow at a time of day when there are few cyclists, or when cyclists do not affect the vehicular discharge rate;
- Measure the traffic saturation flow with cyclists present. Note that cyclists should not be included in the vehicles counted unless they form part of the main queue;
- Calibrate the modelled saturation flow without cyclists present; and
- Introduce cyclists into the model and verify that the saturation flow matches the on-site value including cyclists.

Whether this amount of effort is justified depends on the purpose of the modelling. In theory, it should deliver good results, but it is not a complete solution. The exact methodology to be used should be discussed and agreed in the MAP Stage I Base scoping meeting (section **B2.1.5.1**).

2.6.7 Validation

Before attempting to validate cyclists in a model, it should be considered whether validation is necessary. This will depend on the purpose of the model and should be agreed in MAP Stage I.

Cyclist flows can be validated against surveyed counts in the same way as for general traffic. Any routing should be checked to ensure that it looks sensible. In addition, there should be a visual validation of cyclist trajectories to ensure they match those observed on site.

The observed average travel times from GPS data (section [C2.3.2](#)) can be used to validate microsimulation Base model results. For each validation route the validation of cyclist travel times should be carried out in a similar way to other traffic and using the standard validation criteria.

Based on research TfL has undertaken, it is recommended junction approaches are excluded from validation using GPS data. Travel time markers should be placed beginning in the centre of one junction and ending 10m before the stopline of the next junction ([Figure 159](#)). This has been found to improve validation. A potential reason for recommending this is due to the compliance level of cyclists at red signals. As described in section [C2.4](#), to provide a fair comparison with proposals, cyclists should be assumed to be compliant with red signals in Base and Future scenarios.



Figure 159: Diagram showing Travel Time Section start and end locations

3 Pedestrian Modelling



3.1 Introduction

The Mayor's Transport Strategy has placed a focus on improving London's walking environments in order to promote active, inclusive and safe travel. More appealing streets and footways encourage people to walk more, improve the quality of journeys that are already walked all or part of the way, and enable everyone to make the most of their local area. This is particularly important in town centres, around homes, workplaces, schools, and transport hubs.

In recent years there has been progress towards ensuring the provision of a more balanced transport impact assessment for all schemes, particularly for those with an emphasis on Healthy Streets. As such, there is requirement to consider pedestrian assessments for any scheme in Greater London which includes signalised crossings, TLRN footways, TfL bus stops or any other TfL assets. For schemes that are anticipated to affect a large number of pedestrians or have significant impacts on movement at street level, pedestrian modelling would be considered a requirement. TfL has evolved existing road scheme assessment techniques so that they are more appropriate for modal interaction and ultimately more reflective of the modern road network.

This chapter explores the modelling approach applied to a pedestrian / walking infrastructure scheme assessment. It considers currently available

modelling tools (LEGION, described in section [C3.3.2.1](#) and Viswalk, described in section [C3.3.2.2](#)) and the best practice methodology. The aim is to provide a point of reference to those considering Healthy Streets schemes that specifically focus on walking provision enhancements, as well as traffic schemes that incorporate pedestrian facilities into the wider scope of the proposals.

This chapter is intended to assist both a technical and non-technical audience, and to provide guidance to transport professionals assessing pedestrian conditions in the surface level environments of Greater London. These environments include but are not limited to:

- Pedestrian areas on the TLRN;
- Areas that contain TfL assets such as traffic signals (for example pedestrian crossings) or bus stops;
- Surface level public transport hubs which serve TfL services such as buses, coaches and trams; and
- Areas around rail stations which serve TfL services such as the Underground, Overground and DLR.

The objective is to produce safe, pleasant and functional pedestrian environments by establishing a consistent approach to the planning and implementation of modelling. Schemes should deliver improvements for pedestrians that are well-designed, fit for purpose, cost effective, and sustainable.

3.1.1 Case Study

This case study has been included to showcase the improvements in pedestrian modelling processes which have been brought about over recent years in order to provide robust assessments of network changes on pedestrians.

The Parliament Square Streetscape Project (PSSP) examined the feasibility of developing and implementing a scheme of security, public safety and public realm improvements in the vicinity of Parliament Square, outside the Palace of Westminster and Westminster Abbey. It was proposed by the Mayor of London, TfL and Westminster City Council with the aim of improving the local environment for workers, visitors and residents alike. As part of the design, sections of Parliament Square and the road from Lambeth Bridge roundabout are closed to through traffic, so the proposals affect pedestrian and vehicular movements in and around the square. As such, modelling was undertaken to understand the impact of the proposed alterations on pedestrian flows and journey times through the area, to inform the design and next stages of the project.

Figure 160 shows the layout of the proposal and the modelled area. The detached area to the bottom left depicts the underpass which stretches from Westminster Bridge, through Westminster Underground station, to the lower end of Whitehall, as in LEGION different vertical levels are modelled separately and linked together. The underpass is linked via relevant staircases to the rest of the model.

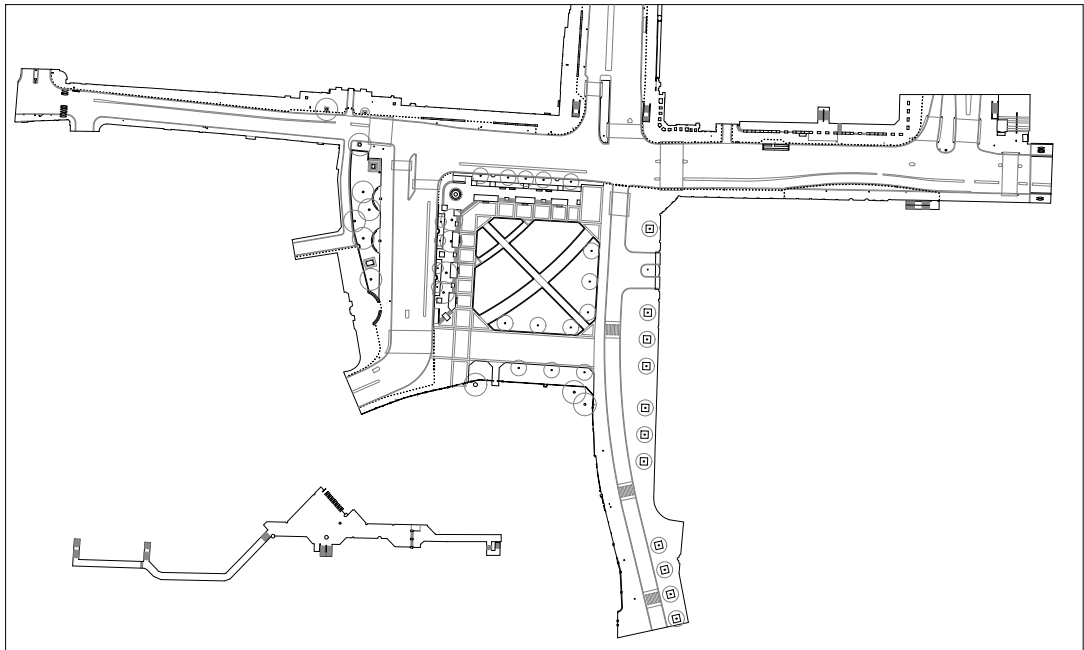

Figure 160: Layout of PSSP proposal

Until relatively recently, surface pedestrian modelling has been carried out on an ad hoc basis and has not been subject to the same prescribed processes as vehicle modelling. Change has come about due to the increased focus on Healthy Streets and the need to quantify benefits to pedestrians where schemes are intended to provide improvements, and to ensure they are considered and not disadvantaged by other schemes.

A pedestrian modelling study should be an expected contribution to a more balanced transport impact assessment for all schemes, and particularly those that have an emphasis on Healthy Streets. This is in order to better understand the operational impact and interactions between modes sharing road space, and more effectively capture relative performance measures as part of a cost benefit analysis exercise. The traditional approach that only considers the impact of pedestrian provision on traffic performance is no longer appropriate for modern transformational scheme assessment.

Specific aims of pedestrian modelling include:

- Understanding route choice;
- Identifying potential safety issues;
- Identifying potential points of congestion;
- Testing signal timings for pedestrians;
- Verifying that footway and crossing widths are adequate; and
- Deriving pedestrian journey times and social costs which can be used in scheme assessments.

The methodologies used in PSSP were peer-reviewed by an external consultant to verify that they provided a robust assessment process which could be taken forward to future schemes. Parliament Square provides a wide-ranging example of street-level pedestrian modelling as it contains many different features which are obstacles to pedestrians, including trees, bollards, lamp posts and hostile vehicle mitigation. It has a tube station, bus stops and crossings and also includes different types of pedestrian, including commuters who know where they are going and large numbers of tourists who stop to look around and take photos. All these features needed to be included in order to make the model as close to reality as possible and achieve the aims of the modelling assessment.

In order to incorporate these features, data from multiple sources was used, including passenger numbers for Westminster station, passenger numbers and timings for local bus routes, and interchange data to estimate the numbers who changed between bus and train or between bus routes. Innovative methods were used to combine these datasets to produce an OD matrix (section [C3.4.6](#)) and assist in more accurate routing. An advantage for PSSP was that the pedestrian modelling was planned from the beginning of the project. This meant the pedestrian models could be built in parallel with traffic models to ensure consistency between the signal timings, and any possible impacts of vehicles on pedestrians or vice versa could be reflected in the modelling.

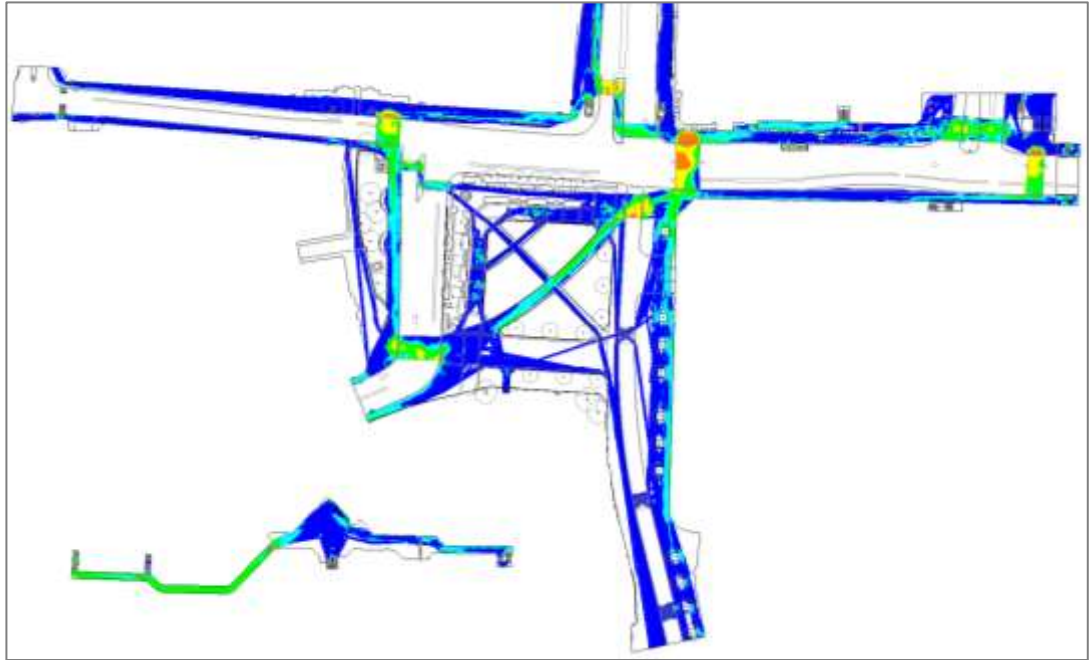

Figure 161: Heat map showing the Cumulative Mean Density for pedestrians across the peak 15 minutes, using Fruin's LoS for walkways

Lasting improvements have also been made to the pedestrian modelling assessment and reporting processes. These have carried through to future projects and include:

- Creation of a pedestrian-focused Modelling Expectations Document (section **B2.1.5.2**) outlining the requirements for all stakeholders at the start of the project, including software versions, scenarios, programme estimates and outcomes;
- Calibration and validation recorded and reported on in a clearer way (including diagrams with tables to outline flow differences);
- Detailed reporting that can be used as the basis for future pedestrian modelling reports;
- Ability to calculate social costs (section **C3.6.4**) within modelling, using pedestrian journey times and weightings based on type of movement (walking / queuing / waiting);
- Routine use of heat maps (**Figure 161**) showing the average level of service experience, giving a better understanding of the implications of the scheme and which areas experience most congestion; and
- Creation of 3D visuals for high-profile schemes.

A further goal is to include pedestrian modelling in the upcoming version of MAP (section **B2.1.5**), so that all surface-level schemes and types of modelling will be subject to similar levels of verification and oversight.

At the time of publishing, PSSP has not progressed past the feasibility stage, however it is already possible to get an idea of how the scheme would look since the project included producing 3D visualisations, as shown in **Figure 162**. Including 3D visuals in the modelling outputs gives all stakeholders a clearer picture of how the scheme would work and is useful for conveying technical data to a non-technical audience.



Figure 162: 3D visualisation of the PSSP modelling

3.2 Relevant Guidance Documents

The TfL publications outlined in this section are important references for pedestrian planning studies. Information provided in these documents should be used to supplement street level modelling studies as appropriate. For pedestrian assessments which will be submitted for approval by TfL, the guidance in Modelling Guidelines should be followed in conjunction with more detailed technical guidance provided in these TfL documents.

Pedestrian modelling has been used by London Underground (LU) for many years and, although based around station design, their guidance documents provide a useful reference when carrying out street-level modelling.

The Pedestrian Comfort Guidance for London (PCGL) and Legion Best Practice Guide (LBPB) are heavily referenced in this document as they have the most relevance to street-level pedestrian modelling. Station Planning Standards and Guidance (SPSG) may be useful if the area to be modelled contains a station or other building where the configuration inside is relevant. The Planning for Walking Toolkit contains guidance on designing, rather than modelling, pedestrian spaces but is a useful reference. Finally, the two software manuals provide specific advice on how to get the most out of the pedestrian modelling software.

3.2.1 Pedestrian Comfort Guidance for London



The PCGL¹²³ (with supplementary spreadsheet templates) is aimed at anyone involved in planning London's pedestrian spaces. It is intended to ensure that the design of footways and crossings is appropriate for the volume and type of users. The guidance is applicable whether evaluating a new design or an existing footway. Outputs include Pedestrian Comfort Levels (PCL, sections **C3.3.1.1** and **C3.6.1.2**) and can be used to derive appropriate signal timings or crossing widths (section **C3.3.1.2**).

123 PCGL <http://content.tfl.gov.uk/pedestrian-comfort-guidance-technical-guide.pdf>

3.2.2 LEGION Best Practice Guide



The LBPBPG¹²⁴ summarises the key steps for modelling TfL stations using LEGION pedestrian simulation software. At the time of publishing, specific guidance on modelling footways and crossings is due to be added to the latest version. It promotes a consistent approach to LEGION modelling studies through the creation of robust models that deliver accurate and reliable results.

3.2.3 Station Planning Standards and Guidelines



The SPSG¹²⁵ document is LU's source document for space planning in stations. It establishes the requirements for all station works that affect passenger movement or that have an impact on overall station size. Further information can be found in section **C3.3.1.4**.

3.2.4 Planning for Walking Toolkit



The Planning for Walking Toolkit¹²⁶ is a handbook providing advice for planners and designers involved in the redesign or creation of pedestrian areas, including streets, off-road footpaths and public spaces across London. It aims to embed good practice urban design principles in the planning and design process, setting out these principles alongside recommended analytical tools. It provides guidance on subjects from data collection and identifying existing issues through to supporting the development of the design brief in order to set the vision for creating good environments for walking.

124 LBPBPG

125 G371A – Station Planning Standards and Guidelines, Issue A4, Transport for London, May 2012

126 <http://content.tfl.gov.uk/the-planning-for-walking-toolkit.pdf>

3.3 Modelling Approach

When changes are made to a surface level pedestrian environment as part of redesigns, planned works or events, the impact on pedestrians should be considered. Changes which should be assessed include:

- Adjustments to the street-level space provided to pedestrians (for example footways);
- New or redesigned pedestrian crossings;
- Changes to walking routes; and
- Redesign of public transport stations.

It is advisable to consult with NP to confirm if an assessment of pedestrian conditions is required. Any scheme that may have an impact on pedestrians should be considered and a decision made based on pedestrian demand, location and scheme objectives. Once the need for pedestrian modelling has been identified, a decision can be made as to what type of analysis is required.

Pedestrian modelling can be split into two distinct types, static and dynamic (also known as microsimulation). Static assessment is usually carried out in spreadsheets and is described in full in this section. Dynamic modelling involves specialist pedestrian modelling software and is far more complex to carry out. It is covered in the remainder of the chapter. An individual scheme may require static or dynamic modelling, or a combination of the two approaches.

3.3.1 Static Modelling

A static assessment is a form of deterministic modelling (section [A3.4.1](#)) as the results are fully determined by the inputs, meaning the same inputs will always give the same outputs. NP have developed a number of spreadsheets that can be used when looking at different aspects of the pedestrian experience. These are applied to schemes where it has been decided that full dynamic pedestrian modelling is not necessary or possible. Static assessment can be undertaken to provide technical reassurance when assessing the condition, with regard to pedestrian usability, of public spaces across different scenarios.

The two main forms of static assessment that are used are:

- Pedestrian Comfort Levels (PCLs) on footways and crossings; and
- Journey times and delay at signalised pedestrian crossings.

The limitation of static assessment is that it does not consider variable flow rates, which may occur due to conditions such as the arrival of pedestrians exiting a bus. Consequently, static assessment is best suited to projects that do not have complex requirements or are constrained by the project timescales. Static assessment may be more appropriate for small-area, low population, studies such as a section of footway or a simple pedestrian crossing design.

Conversely, static assessments have very low data and time requirements. They will usually only need:

- Diagrams of the layout, which can be measured in order to determine the dimensions of the areas available to pedestrians;
- Current or predicted pedestrian volumes in the form of hourly bi-directional flows at each section of footway or crossing being evaluated; and
- Signal timings of the crossings.

Once these are available, the spreadsheets can be filled in and the results generated for any scenario or time period which is required.

When a surface level pedestrian environment is being assessed statically, a best-fit approach using the most appropriate published guidance should be adopted, with all assumptions documented as part of a technical note. This should identify whether it is pedestrian comfort, signal timings or specific design elements that need to be assessed and detail which static assessment technique(s) is being used. It is recommended that agreement is reached, on a case-by-case basis, with all relevant stakeholders, on the approach and guidance that will be used. It may be necessary to undertake a mixture of assessments or even a combination of static and dynamic modelling. This approach has proved useful for producing PCL outputs for future (predicted) conditions where pedestrian flows on footways are measured from a dynamic model and used as inputs for PCL spreadsheets.

The different static assessment methods are outlined below.

3.3.1.1 Pedestrian Comfort Levels

For surface level static assessments, the most common requirement is the calculation of PCLs. Section [C3.6.1.2](#) shows how measurements of people per metre each minute (ppmm) are converted into PCLs and gives a description of what each level is like for a pedestrian to experience. Whether each level is considered acceptable is dependent on the type of area that it is applied to. For example, a retail area such as a high street would become unacceptable to pedestrians at a lower PCL than a transport hub. Pedestrians may consider going elsewhere if a high street

reached PCL B- or C+, whereas they could tolerate the transport hub up to PCL C- or D. **Figure 163** shows PCLs applied to different sections of footway. It highlights general areas which may have capacity problems.



Figure 163: Pedestrian Comfort Levels applied to sections of footway

PCL calculations require footway dimensions and average and peak hourly pedestrian flow rates. If a crossing is to be assessed then the signal timings are also required. Further information on how PCLs are measured and applied can be found in TfL's guidance document, *Pedestrian Comfort Guidance for London (PCGL)*¹²⁷, which also includes a spreadsheet that contains the calculations.

Following this process can provide information to those assessing the validity of a scheme by way of offering high-level outputs demonstrating how crowded pedestrian areas may become. For proposed schemes, levels of crowding are derived from forecasted pedestrian flows and the proposed dimensions of pedestrian spaces, and can be used to assess how these levels compare to the existing situation.

127 *Pedestrian Comfort Guidance for London – Guidance Document, Version 2, Transport for London, 2019*

3.3.1.2 PCLs and Signal Timings at Crossings

As mentioned in the previous section, PCL calculations can be used to assess pedestrian crossings. This also includes any islands that may be part of a staggered crossing.

The following input data is required:

- **Pedestrian phase green time [gt] (s);**
- **Pedestrian phase blackout [bl] (s)** – this is a safety-critical value based on the length of the crossing¹²⁸ (the width of the road). Depending on the type of crossing, it may include flashing amber or pedestrian countdown;
- **Pedestrian crossing width [w] (m)** – the distance between the rows of crossing studs;
- **Cycle time [ct] (s);** and
- **People per Hour [pph]** – Hourly pedestrian flow, at average and peak levels.

The spreadsheet then calculates the following:

- **Percentage Time available to Cross [%tc]** – This is the proportion of time in a signal cycle that people can cross the road (during the green man and blackout periods). Given as; $\%tc = \frac{gt+bl}{ct}$; and
- **Relative People per Hour [rpph]** – This figure is used in the assessments and describes the equivalent number of people per hour that would cross the crossing if it was permanently on green and the crossing rate remained the same. It is calculated by dividing the pph by the percentage of time available to cross. Given as; $rpph = \frac{pph}{\%tc}$.

Using these values, a PCL is derived from Figure I77 in section 3.6.1.2 using the following formula:

$$ppmm = \frac{rpph}{60 * w}$$

This ensures that the PCL only applies to the crossing when it is in use.

As well as assessing existing and proposed PCL levels, PCL calculations can be used in reverse to provide indications of optimal pedestrian green times or required crossing widths for a particular proposed PCL, based on existing and future pedestrian flows.

In order to decide on appropriate crossing timings given a fixed width (w), predicted flows (pph) and a required PCL (for example, B+ which is 9 $ppmm$), manipulating the above formulae gives the following:

$$\%tc = \frac{pph}{rpph} = \frac{pph}{60 * w * ppmm}$$

The $\%tc$ value can be used in conjunction with the cycle time and the blackout to obtain a minimum green time for the pedestrian phase. The $ppmm$ value should be assumed to be within the range of the required PCL. It should be no greater than 17, which is the cut off for the B- comfort level. Once these timings have been produced, the spreadsheet then compares the proposed green and red pedestrian times with the required ones to see if they would be viable.

If the $\%tc$ is greater than or equal to 100% it indicates that the crossing is not wide enough to accommodate the flow of pedestrians. The people per hour must be less than the relative people per hour ($pph < rpph$). This assessment method cannot calculate meaningful signal timings if the crossing width is not wide enough. The minimum width can be calculated and input in order to continue and test signal timings. Any issues with the proposed crossing width should be fed back to the scheme designer.

To calculate the minimum width required for a specified PCL the following formula is used:

$$w = \frac{rpph}{60 * ppmm}$$

The spreadsheets can be used on multiple crossings and the cycle times can be adjusted to test further mitigations and impacts. It is important to take note of traffic signal arrangements such as SCOOT regions and minimum green times.

For further information on this method of assessment refer to the PCGL¹²⁹ and for further guidance contact StreetsPedestrianModelling@tfl.gov.uk

3.3.1.3 Wait Times at Signalised Crossings

NP has created a spreadsheet that can be used to assess average wait times and journey times at signal-controlled pedestrian crossing facilities. It can be used for up to four linked crossings to assess direct and staggered configurations.

¹²⁹ Pedestrian Comfort Guidance for London – Guidance Document, Version 2, Transport for London, 2019, accessible at <http://content.tfl.gov.uk/pedestrian-comfort-guidance-technical-guide.pdf>

The spreadsheet calculates the wait time and journey time for a pedestrian arriving at the crossing at each second of the cycle time. It uses these values to identify the average, minimum and maximum wait times and journey times.

Where staggered crossings are involved, the offsets between the crossing signal timings and walking time between the crossing points are considered. The walking speed is assumed to be 1.2m/s, although this can be adjusted if required. Calculations are automatically produced for both crossing directions. The following input data is required:

- Pedestrian phase start of green (s);
- Pedestrian phase end of green (s);
- Pedestrian crossing length (m);
- Distance between crossings (m); and
- Cycle time (s).

In some cases, such as asymmetric double-cycling of staggered crossings, the spreadsheet may need to be manually adjusted.

The spreadsheet can be used to provide a high-level comparison of pedestrian impacts between different junction designs and/or different sets of signal timings.

For access to the spreadsheet email
StreetsPedestrianModelling@tfl.gov.uk

3.3.1.4 Station Planning Standards and Guidelines

Although the focus of these Guidelines is street-level modelling, there may be occasions where it is necessary to consider pedestrian behaviour inside structures, for example, for the assessment of elements within surface level public transport stations. TfL has produced a guidance document “G371A - Station Planning Standards and Guidelines” (SPSG)¹³⁰ which forms a guide to LU’s Station Planning Standard number SI371. The Station Planning Standard is LU’s source document for space planning in stations and applies to all LU stations, existing and planned. It establishes the requirements for all station works that affect passenger movement or that have an impact on overall station size. The guidance document includes examples of static assessment approaches based on spreadsheet calculations which may be relevant to any public transport station. These calculations focus on short time intervals (such as peak minutes) and outputs are typically limited to identifying the minimum size and quantity of discrete elements, such as staircases and ticket gates. The inter-

relationship of such elements is usually beyond the model's capability. For further guidance in relation to a particular scheme contact

StreetsPedestrianModelling@tfl.gov.uk.

3.3.2 Dynamic Modelling

Dynamic pedestrian modelling, which is a form of microsimulation modelling, provides a more detailed representation of pedestrian movement than static modelling, as it simulates individual pedestrians and how they interact. Different types of pedestrians, for example men, women, tourists and commuters, can be modelled if required and the data is available. These can be given different speeds and routing based on research and data collected on site. For example, tourists with suitcases take up more space and are likely to move more slowly than commuters who travel to the area every day. This variability means that dynamic models are a more accurate representation of real life and can provide valuable insights into the performance of pedestrian spaces.

Dynamic modelling has the visual benefit of being able to present crowding maps and videos of recognisable two-dimensional plans, which can easily highlight problem areas and display the model outputs to a non-technical audience. It also measures pedestrian walk times which can be used to demonstrate the performance of various layouts and also to provide social cost outputs for different options and scenarios, which can be used for assessing schemes. Further information on dynamic outputs can be found in section **C3.6**.

Dynamic modelling requires a large amount of data which in turn takes longer to process compared to a static assessment. When a need for dynamic modelling is anticipated, it is recommended that NP is consulted at an early stage so resources can be allocated and data requirements identified.

The software involved in pedestrian microsimulation can be specifically designed to model pedestrians only or it may be integrated as part of traffic microsimulation. The two pedestrian modelling software packages used by NP are LEGION, which only models pedestrians, and Viswalk, which is integrated within Vissim (see Chapter **B7** on **Vissim Modelling**). Any pedestrian modelling which will be submitted for approval by TfL should therefore be completed in either of these packages.

The rest of this chapter applies to all dynamic pedestrian modelling, whether LEGION or Viswalk is used (any exceptions will be noted).

3.3.2.1 LEGION

LEGION is pedestrian modelling software developed by Bentley Systems¹³¹ which represents pedestrians as adaptive agents and treats pedestrian movement as a multi-agent complex system. The interactions between individual pedestrians lead to crowd behaviour emerging naturally rather than being explicitly modelled. LEGION uses inputs along with other types of object such as direction modifiers and drift zones, in order to best represent pedestrian movement and interaction in the modelled area. LEGION has been used for many years by LU to model passenger behaviour in stations and is also often used to model high-profile surface schemes. A screenshot from the LEGION Model Builder is shown in **Figure 164**.

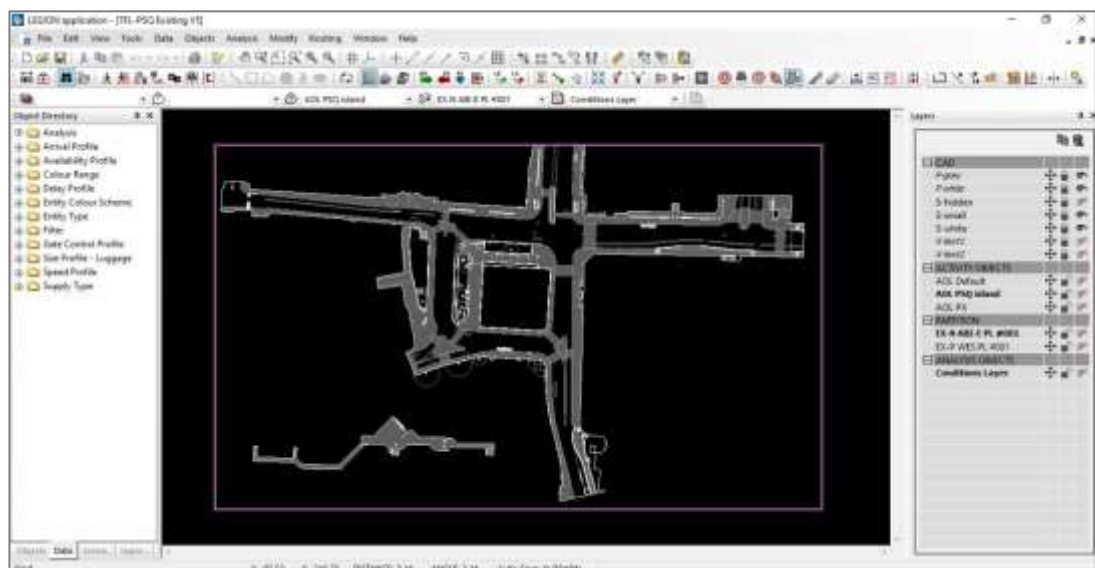

Figure 164: LEGION Model Builder screenshot

LEGION cannot explicitly model signalised junctions or crossings. Signal control is simulated using waiting zones, where pedestrians are stationary for a defined and fixed period of time, so adaptive timings are not possible. In addition, LEGION does not include vehicles and so cannot predict situations where vehicles may affect pedestrian movements or vice versa.

More technical guidance which sets out best practice that modellers should adhere to when using LEGION can be found in TfL's Legion Best Practice Guide¹³². This contains reference to numerous different scenarios encountered on TfL projects, including those at a surface level. This

¹³¹ <https://www.bentley.com/en/products/brands/legion>

¹³² Modelling with LEGION: TfL Best Practice Guide, v4.0, Transport for London, June 2019

document is available on request when working on a project for or on behalf of TfL.

3.3.2.2 Viswalk

Viswalk, developed by PTV AG¹³³, specifically models pedestrians in urban areas. Pedestrian movement in Viswalk is built on a ‘social force’ model, so movement is based on forces assumed to be exerted by pedestrians and obstacles. Viswalk uses inputs in order to best represent pedestrian movement and interaction in the modelled area. The key benefit of Viswalk over other pedestrian modelling software is that it is integrated seamlessly within Vissim, so it can take advantage of all Vissim’s signal control capabilities and investigate the impact of interactions between vehicles and pedestrians. Viswalk can also model in 3D, so that features such as footbridges, underpasses and stairs can be built in the correct location with the appropriate height or depth. **Figure 165** shows the Network Objects window in Vissim with the objects which are available for use when modelling pedestrians.

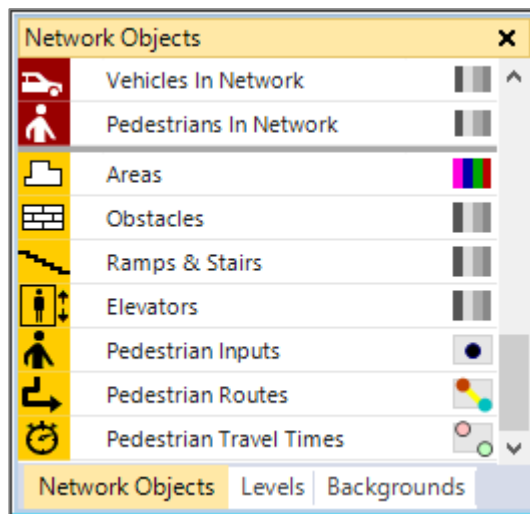

Figure 165: Pedestrian part of the Network Objects window in Vissim

For the purposes of this document, it is assumed that Viswalk is being run from within Vissim to gain the full benefit of pedestrian-vehicle interaction, further information on the use of Vissim can be found in Chapter **B7** on **Vissim Modelling**. TfL’s use of Viswalk is relatively new therefore further detailed guidance is not yet available.

3.4 Preparation

Once a decision has been made to carry out a dynamic modelling assessment, there are various requirements before modelling can begin. Preparations and inputs may vary from project to project but should always consider the elements described in the following section.

3.4.1 Modelling Expectations Document

A successful Modelling Expectations Document (MED) will aid efficient production of the necessary preparations and inputs required to complete a pedestrian modelling project. Section **B2.1.5.2** contains a detailed summary of the information that should be included in an MED, however, pedestrian modelling has a separate MED as there are some particular aspects which need to be considered. The amount of detail to be included should be proportionate to a study's scale and complexity.

Pedestrian modelling should be considered from the start of the project, in particular, the aims of the modelling and how both the modelling process and these aims could be integrated into the wider modelling work.

Pedestrian modelling has specific data requirements which should be considered and recorded as early as possible to ensure that site visits can be arranged which cover the relevant time periods.

Pedestrian time periods may need to be different to those of any associated traffic modelling. If this is the case it should be recorded, along with the reasoning and the expected source of signal timings for any extra periods of pedestrian modelling.

Pedestrian models require a high level of detail for the street environment. Existing CAD drawings should be examined to ensure that they are suitably detailed to provide a realistic assessment of the environment, for example, there may be a recent topographical survey. If this is not the case, then more time may need to be allocated to record the locations of street furniture and relevant features.

Finally, the MED should record the data sources that will be used to calibrate and validate the models, and any validation criteria that will be required. It should also detail the outputs that are expected, based on the type of modelling assessment and the results that are needed to demonstrate the outcomes of the scheme.

3.4.2 Time Periods

Typically, as a minimum, two peak periods of a day in terms of demand are modelled. These are generally the recognised weekday AM (07:00-10:00) and PM (16:00 to 19:00) peak periods. However, the actual peaks should be measured from demand data and utilised in the modelling. Likewise, other periods may also be relevant if it is known that a site is busy on weekends or outside of the usual peak periods, or if an assessment is being made for an event at a particular time of day.

If it is deemed that a three-hour model is not necessary then, as a minimum, the models should cover the actual peak hour period being assessed. The warm-up and cool-down periods are recommended to be 30 minutes but should cover, as a minimum, the length of time required for pedestrians to complete their journey within the model or 15 minutes, whichever is longer. Therefore, an absolute minimum period of 90 minutes per scenario should be modelled.

3.4.3 CAD Preparation

Once the study area and layouts of the pedestrian modelling have been agreed on as part of the project scoping, CAD drawings should be used that provide adequate detail to perform a realistic assessment of pedestrian space. CAD files are typically organised in layers so that different features, such as kerb lines, buildings and bollards, would be on different layers. Logical organisation of layers can significantly improve model building.

The assessment of pedestrian space is based on a two-dimensional representation of what the pedestrian experiences and can be considered in the same way as viewing a map. Therefore, all street furniture that acts as an obstacle at ground level should be included, such as lampposts, cycle racks, barriers, bollards and bus shelters. For street level assessments it is preferable to use topographical CAD, as this will contain sufficient detail of these obstacles.

Even with a topographical survey, it is recommended to complete a site inspection to check there are no changes to the area that impact pedestrian space. Also, time should be taken to detail any temporary objects that may not have been included in the CAD, such as café tables and chairs and pop-up advertising signs. For areas without a topographical survey, an OS tile can be used, however most street furniture must be added, and correct building and kerb lines checked. In this case it would be required to undertake a site visit to confirm the dimensions given by the

CAD as OS data has a relative accuracy of ± 1.1 metres¹³⁴, which could be significant when dealing with pavement widths, for example. An example is shown in **Figure 166**, where the OS tile pavement outline is shown in blue and the topographical survey is shown in red. The top right corner of the image demonstrates a significant difference.



Figure 166: CAD showing an OS tile and topographical drawing

Consideration should be given to the appearance of the CAD when presenting modelling work to a non-technical audience, so the CAD and layout of the models are as easily recognisable as possible. It is recommended that this is considered at the beginning of a project, to ensure consistency between modelling work and presented results, and because changing background data late in the project is not advisable. Street layouts should reflect how they appear on most maps, with north at the top. The CAD drawings of all existing and proposed layouts should be aligned with each other to assist the audience in visualising how the assessed future year will look in comparison to the existing layout.

Consideration should also be given to what CAD is presented and what should be hidden. It is recommended that separate CAD layers are used appropriately, so that CAD included for simulation purposes only can be hidden and, conversely, CAD that should be viewed can be presented but have no impact on the simulation. For example, a street level model may include a pedestrian crossing. In this case the kerb line should be visible

¹³⁴ <https://www.ordnancesurvey.co.uk/business-government/tools-support/mastermap-topography-support>

but not serve as an obstruction. This line should therefore be in a presentation layer but not a simulation layer. This applies more to LEGION than Viswalk as CAD cannot be used directly as a simulation object in Viswalk, although appropriately formatted data can be converted for use.

More detail on CAD preparation can be found in the relevant pedestrian modelling software guidance.

3.4.4 Public Transport Hubs

It is common for a surface level model to include a transport hub such as a train or bus station. Pedestrian flow generated by the hub can dominate other flows in the area so it is important that this is captured and modelled in sufficient detail for its impact to be represented. If the hub has multiple access points then these may need to be modelled separately, or it may even be necessary to include key areas such as ticket halls and gatelines. The level of detail required should be agreed prior to data collection so that the appropriate surveys can be specified.

3.4.5 Data Collection

Pedestrian modelling has more complex data requirements than other types of modelling due to the fact that pedestrians can start and end their journeys at any point in a network and, within reason, are not constrained to any particular route in between. They can travel at any speed and may pull bags behind them, use a wheelchair or mobility scooter, concentrate on their phones or travel together in groups. Their behaviour also changes depending on their journey purpose and whether they know the area well. Whilst it may not be possible to collect all this information and it may be too detailed for the modelling project, it is useful to be aware of the general characteristics of people that usually frequent the scheme area. This section provides guidance on the data collection process required for the assessment of pedestrian environments. Further information on data collection can be found in section **B2.3**.

3.4.5.1 Site Observation

Dynamic models can simulate complex interactions between pedestrians and their environment. It is therefore essential that on-street observations are undertaken at sites being modelled so that interactions can be noted and replicated in the model. It is not sufficient to use drawings and aerial photography only to build a model, as these are static sources and may not convey all the dynamic aspects of the site. CCTV may also be used; however, this is not an ideal solution as not all areas are covered and it is

easy to pay less attention to areas which cannot be seen. Preferably, CCTV would be used in addition to, rather than instead of, site visits.

Site visits and surveys should include observations about pedestrians' behaviour and decision making. Features and conditions that induce unexpected decisions should be noted. A site visit can be helpful in understanding pedestrian routing, in particular identifying:

- Any preferences for routes that avoid congested areas but involve longer journeys, or a dislike of pedestrian crossings with long wait times;
- Situations where pedestrians congregate in large numbers and may be present at the start of a study period, for example queuing or waiting;
- Points of Influence, waypoints or intermediate destinations. For example, ticket machines, cash points or queues;
- The impact of sinks and sources, which include shops, cafes and other buildings not considered a main entry or exit point to the analysis; and
- Informal crossing points where pedestrians cross the road away from a designated crossing. This behaviour should be noted adjacent to existing crossings to ensure that these movements are captured in the demand for the crossing points, and also in situations where no crossing is present, if significant numbers of pedestrians are involved.

These can significantly affect model results and must be understood from site visits in order that they can be accurately replicated in the model.

It is also important, whenever possible, to carry out site observations on days when other surveys, for example counts or journey times, are taking place. It is necessary to verify that the data collected represents a day that is considered typical or the data collection may need to be repeated at a later date.

Useful information on site visits for pedestrian data collection can be found in the appendices to PCGL¹³⁵.

3.4.5.2 Dates and Times

Whenever possible, pedestrian surveys should be undertaken for different time periods on the same day to ensure consistency. It may be appropriate to repeat counts on multiple days to ensure that the survey day is representative. In addition, there may be a need to amalgamate data from other sources such as rail, tube or bus data, where applicable.

¹³⁵ Pedestrian Comfort Guidance for London – Guidance Document, Version 2, Transport for London, 2019, accessible at <http://content.tfl.gov.uk/pedestrian-comfort-guidance-technical-guide.pdf>

There is a need to consider the time periods for which data is collected. This can vary depending on the project requirements. For example, collecting data in 5- or 15-minute time periods might be appropriate for a larger model site, but for a project involving a single pedestrian crossing it might be more appropriate to collect data every minute or each cycle time of the junction.

Unless the assessment is specifically looking at a particular scenario, it is important to ensure that the data collected is not impacted by any events or incidents in the immediate or wider area. When trying to survey for an average day or time, ensure there are no events such as protests, football matches, tube closures or rail replacement buses. Counts should usually be carried out on a standard working day during term time.

The weather can have a huge impact on pedestrian movements, so it is vital to take this into account when surveying. Poor weather can mean higher use of private vehicles or public transport which could skew an assessment.

3.4.5.3 Flows and Journey Times

There are several sources of flow data that can be collected to assist a pedestrian modelling assessment, these can include:

- Manual Classified Counts, which involve a person on street counting different types of pedestrians making particular movements, for example across a crossing or along a section of footway;
- Video surveys, for counts and journey times; and
- Wi-Fi / Phone signal / Bluetooth capture methods.

When commissioning pedestrian count or journey time surveys it is important to consider the locations of each camera, enumerator and survey point carefully. It is necessary to ensure that there is no bias or impact on pedestrian movement as a result of obstructive surveying methods. When considering locations of cameras, it is recommended to locate these on existing infrastructure whilst also being careful to think about potential obstructions to the view. For example, if the camera is set up on the southern footway looking at the northern footway will the camera view be obstructed by a bus or large lorry? Are there any trees in the area that may move in the wind obscuring the view? For enumerator locations, are they in a suitable place for someone to stand without obstructing the usual flow of pedestrians?

It is necessary to capture the total flows at each entry and exit point, as well as a suitable number of internal footways and crossings for calibration and validation purposes. With dynamic models of pedestrians,

careful consideration needs to be taken of sinks and sources. It will not be possible to model every single entry and exit point of a surface level model, for example individual houses, workplaces or shops. However, it is important to model all the main entry and exit points, such as schools, large offices and housing developments.

For journey time data it is necessary to collect pedestrian journey times on the key routes for model validation. Journey times should be collected across each peak hour being modelled, ensuring a random selection of pedestrians is chosen. It is important that enough pedestrians are surveyed for each PRM type to ensure a robust average.

It is necessary to ensure that all data collected and used in a project is GDPR-compliant and that individual pedestrians cannot be identified. For further information or details contact

StreetsPedestrianModelling@tfl.gov.uk.

3.4.5.4 Public Transport Data

If an area is being surveyed for pedestrian flows then it is important to include any public transport impacts such as bus, coach or tram stops and rail and underground station entries and exits. Boarding and alighting at each of these should be included in any pedestrian surveys undertaken. Where this is not possible, or it is known that adjustments to services or routes are planned then specific data can be requested from TfL. This will typically be average data or figures derived through some form of model and will therefore not exactly match any other survey data. Before requesting any data, contact StreetsPedestrianModelling@tfl.gov.uk to ensure that it is suitable for the intended purpose.

Rail data comes from a tool called NUMBAT which can be used to inform the total numbers of people entering and exiting a station. This model represents a typical autumn weekday, Saturday and Sunday for all TfL-run rail and tram stations. Data is split into 15-minute intervals throughout the day and assumes a perfect service is operated.

Bus boarding and alighting data has two different sources:

- ODX data can report exact boarding, alighting, bus to bus and bus to tube interchange data by route and stop in 15-minute time periods. However, this data is subject to GDPR and has specific terms of use. Use of ODX data should be discussed before modelling to determine if it is suitable and/or available for the project; and
- BUSTO is an annual bus demand tool representing a typical autumn weekday, Saturday and Sunday. Data is extracted from ODX and averaged across days of the same day type. As this is aggregated data

it is not subject to GDPR and can therefore be shared externally where necessary.

In addition to usage data, it is important to have either the timetable or average arrival times of the buses to create a profile for boarding and alighting. Actual bus arrival, dwell and departure times are recorded via the iBus system. This data should be requested from a TfL sponsor to ensure the request is valid and formatted correctly. If it is not available then scheduled timetables can be found on the TfL website¹³⁶.

Information on the running of coach lines should be sourced from the relevant operator's website.

3.4.5.5 Signal Timing Data

For models that include signalised crossings it is important to collect traffic signal data. Guidance on the collection and use of signal timing data can be found in section **B2.3.8**.

Signal timings for Base models can be derived from deterministic models built for the scheme or obtained directly from NPD. Where available future year signal timings should be taken from a TfL approved Proposed model of the scheme.

This data should include the following for each pedestrian phase:

- Cycle time;
- Start of green;
- Green time; and
- Any other signal data, such as double-cycling.

Demand-dependent pedestrian stage appearances can be extracted from the Urban Traffic Control (UTC) system. This data is available in aggregated over 15-minute time intervals (section **B2.3.8.5**).

Since Viswalk can make use of Vissim's signal control capabilities Chapter **B7** on **Vissim Modelling** should be consulted when collecting signal data for Viswalk models.

¹³⁶ <https://tfl.gov.uk/travel-information/timetables/>

3.4.6 Demand

The total number of pedestrians within a pedestrian model should be represented in the form of an Origin-Destination (OD) matrix. An OD matrix forms the basis for all model demand inputs as it contains all the sources and sinks which will be modelled. It should cover the agreed model duration.

A difficulty of street level modelling is the potential to require many OD pairs. Where possible, OD matrices should be limited to those essential to the study in order to maintain a usable model structure. It may be beneficial to combine minor roads into a single OD or combine entrances of a station where the station interior is not being modelled.

One way of converting count data into an OD matrix is by a method called Furnessing. This can be carried out in a spreadsheet template using the total number of entities (the visual representation of pedestrians within the model) entering and exiting a model at each location. M&V has an OD Furnessing template that can assist with this process.

Another method of generating OD data is by matrix estimation performed in 'dummy' pedestrian assignment models. This approach uses assignment modelling software such as Visum to build a pedestrian network and enter count data. The model can then be assigned before using the software's matrix estimation procedure to match the count data and generate the OD matrix.

In LEGION, as well as an OD matrix, all entries should have an associated arrival profile in time periods of no longer than 15 minutes, giving a breakdown of the total pedestrian flow every 15 minutes by each entry. Arrival profiles can be generated by the LEGION Data Template (LDT), as shown in [Figure 167](#). An example of the arrival profile for single run, when imported into LEGION, is shown in [Figure 168](#). Public transport hubs such as bus stops and stations should have their arrival profiles based on the service timetables, or 5-minute time periods if timetables are unavailable. For further information on these methods contact StreetsPedestrianModelling@tfl.gov.uk.

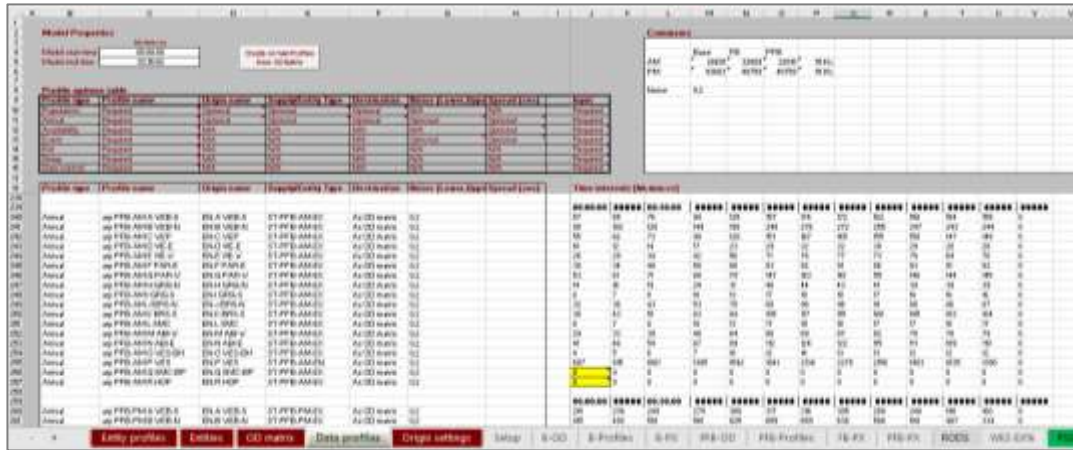

Figure 167: Example of the LDT with arrival profiles in 15-minute sections, noise between 0 and 2 and random arrival within that time period

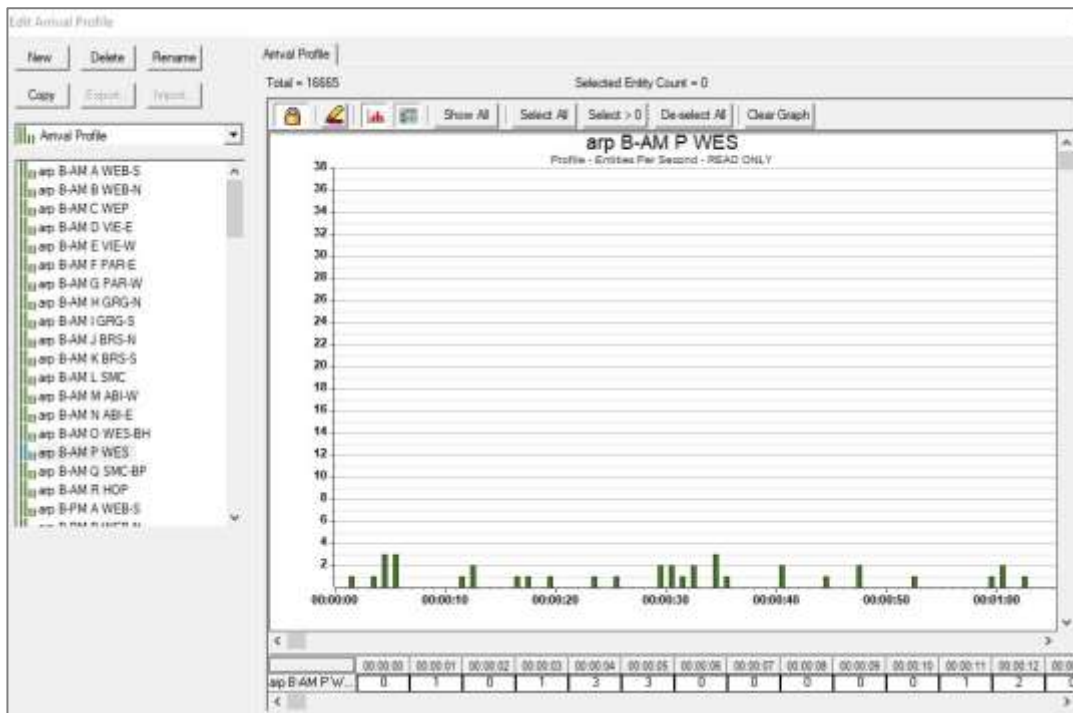

Figure 168: Example LEGION arrival profile

Viswalk pedestrian inputs are entered in OD matrices for each time period, as shown in **Figure 169**. Vissim automatically varies the exact entry time of each pedestrian in different random seeds (section **C3.5.6.1**), whilst still matching these values. The numbers in the OD matrices are in persons per hour, however long the time period which the matrix covers.

Origin \ Destination	100 PED-C	110 WEA-N	120 WEP	130 HE-E	140 HE-W	150 PAR-E	160 PAR-W	170 WGN-N	180 WGS	190 WSN-N	200 WSE-E	210 WNC	220 WSN-W	230 WSE-E	240 WSN-W	250 WSE
100 PED-C	0	0	0	0	0	0	0	0	0	0	0	0	0	0	0	0
110 WEA-N	0	80	0	0	0	0	0	0	0	0	0	0	0	0	0	0
120 WEP	0	0	80	0	0	0	0	0	0	0	0	0	0	0	0	0
130 HE-E	0	0	0	80	0	0	0	0	0	0	0	0	0	0	0	0
140 HE-W	0	0	0	0	80	0	0	0	0	0	0	0	0	0	0	0
150 PAR-E	0	0	0	0	0	80	0	0	0	0	0	0	0	0	0	0
160 PAR-W	0	0	0	0	0	0	80	0	0	0	0	0	0	0	0	0
170 WGN-N	0	0	0	0	0	0	0	80	0	0	0	0	0	0	0	0
180 WGS	0	0	0	0	0	0	0	0	80	0	0	0	0	0	0	0
190 WSN-N	0	0	0	0	0	0	0	0	0	80	0	0	0	0	0	0
200 WSE-E	0	0	0	0	0	0	0	0	0	0	80	0	0	0	0	0
210 WNC	0	0	0	0	0	0	0	0	0	0	0	80	0	0	0	0
220 WSN-W	0	0	0	0	0	0	0	0	0	0	0	0	80	0	0	0
230 WSE-E	0	0	0	0	0	0	0	0	0	0	0	0	0	80	0	0
240 WSN-W	0	0	0	0	0	0	0	0	0	0	0	0	0	0	80	0
250 WSE	0	0	0	0	0	0	0	0	0	0	0	0	0	0	0	80

Figure 169: Viswalk pedestrian OD matrix

3.4.7 Pedestrian Types

When modelling pedestrians there are three main parameters that should be considered: speed, size and choice of route. Pedestrian modelling software should be able to reflect variance in these three parameters, and models should be reflective of the population being modelled.

Differing pedestrian types, including Persons with Restricted Mobility (PRMs), commuters and tourists, should be considered in all models, and have appropriate speed, size and routing profiles assigned. The proportions of PRMs for surface level models should be agreed as part of the project scope, and should be reflective of site survey data where available. Where site-specific proportions are not available it may be appropriate to use the default values as outlined below.

A 50:50 split of male and female pedestrians should be assumed where there is no site-specific data to suggest otherwise.

3.4.7.1 PRM Types

For modelling purposes, TfL has divided PRMs into categories according to the degree to which mobility is restricted. These categories can be used to define behaviour and routing characteristics such as speed and stairs / lift usage. They are defined in [Table 16](#).

Table 16: PRM type definitions

Entity Type	Description	Examples of accompanying items
N	Non-PRM	Handbags, backpacks, umbrella, laptop case, pocket dogs, single shopping bags
A	Wheelchair users	Wheelchairs
B	Passengers with permanent or temporary physical mobility impairments	Walking sticks, guide dogs
C	Non-disabled passengers with heavy luggage	Rucksacks, sports bag, tennis racket bags, multiple shopping bags, toolbox, wheelie case (flight cabin luggage), fold bikes, fishing rods, golf bag, guitar case, (walking) dogs
D	Non-disabled passengers with large luggage	Cello case, all suitcases and large bags (including wheelie cases that are bigger than flight cabin luggage), full-size bikes, flat pack packages
E	Adults with young children (including with pushchairs)	Young children, pushchairs

3.4.7.2 Default PRM Proportions

Proportions of PRMs should be obtained from site surveys wherever possible. The proportions of PRMs defined in **Table 17** were developed for stations and so may not be suitable for a street environment, however, where no site-specific data exists they may be used as a starting point. Decisions on appropriate entity proportions should be agreed during the Base scoping meeting (section **B2.1.5.1**).

Table 17: PRM proportions

Entity Type	Overall Proportions	Time of day variants		Station type variants		
	Default	Inter-peak	Weekend	Outer Suburb	Euston, Paddington, King's Cross St Pancras	Victoria, Waterloo
N	89.40%	86.40%	88.50%	88.75%	85.40%	88.60%
A	0.10%	0.10%	0.10%	0.10%	0.10%	0.10%
B	1.00%	1.50%	1.00%	1.20%	1.00%	1.00%
C	6.00%	7.20%	6.00%	6.00%	9.00%	6.60%
D	2.00%	2.40%	2.00%	2.00%	3.00%	2.20%
E	1.50%	2.40%	2.40%	1.95%	1.50%	1.50%

3.4.7.3 Default PRM Speed Distributions

The speed distributions for PRMs defined in **Table 18** were developed for stations and so may not be suitable for a street environment, however, where no site-specific data exists they may be used as a starting point. Decisions on appropriate entity speeds and sizes should be agreed during the Base scoping meeting (section **B2.1.5.1**).

Table 18: PRM speed distributions

Entity Type	Speed (m/s)								
	1.10	1.20	1.30	1.40	1.50	1.60	1.70	1.80	1.90
N	5%	8%	12%	16%	18%	16%	12%	8%	5%

Entity Type	Speed (m/s)
	0.58
A	100%

Entity Type	Speed (m/s)
	0.80
B	100%

Entity Type	Speed (m/s)								
	1.10	1.20	1.30	1.40	1.50	1.60	1.70	1.80	1.90
C	5%	8%	12%	16%	18%	16%	12%	8%	5%

Entity Type	Speed (m/s)								
	0.90	1.00	1.10	1.20	1.30	1.40	1.50	1.60	1.70
D	5%	8%	12%	16%	18%	16%	12%	8%	5%

Entity Type	Speed (m/s)								
	1.00	1.10	1.20	1.30	1.40	1.50	1.60	1.70	1.80
E	5%	8%	12%	16%	18%	16%	12%	8%	5%

3.5 Model Building and Development

Once the input data has been collected, it can be used to build and calibrate the model. This section provides guidance on how to approach the model build.

A calibrated pedestrian model should have as a minimum:

- Correct fundamental parameters and units;
- The correct, appropriate pedestrian area structure which replicates behaviour on street;
- Appropriate and correct flow and routing behaviour, in accordance with the scope and purpose of the model;
- Correct public transport data collected from reliable sources and modelled accurately. The level of detail of public transport modelling is dependent on the purpose of the model; and
- Appropriate signal control data with representative signal timings for the network during the period under consideration.

A key part of building a properly calibrated and validated pedestrian model is observing the model while it is running. Accurate representation of pedestrian behaviour is necessary for the model to fulfil its purpose. The animation features of LEGION and Viswalk can be used during calibration to identify irregularities in behaviour that may adversely affect model operation. The model should be observed during multiple runs to gain a rounded picture of its performance and provide reassurance that all the network elements are functioning correctly.

3.5.1 Entity Routing

When building dynamic pedestrian models, it is recommended that entities should be left to auto-navigate to their final destination as specified by the OD matrix or hard coded to match observed behaviour. Any intervention by the modeller to control the entities' route and decision-making should be clearly defined and should only be included to make movement more realistic rather than reducing entity congestion in order to make the model run more smoothly.

The overarching aim is that models achieve a good level of realism. To this end it is recommended that the following factors are considered as a minimum when calibrating a model:

- Unrealistic pedestrian movement or behaviour; and
- Unrealistic route choices.

Behaviour should be adjusted with as little intervention as possible and that intervention, when required, should be straightforward and transparent so that it can be understood by anyone reviewing the model.

In LEGION, primary routing between OD pairs should be based on Final Destination assignment and shortest path auto-navigation. User-defined fixed routes to intermediate targets should only be used where essential and the reason for taking this approach should be documented. Before pedestrian crossing operation is introduced, it is important to simulate the shortest-path auto-navigation between OD pairs in order to get the true shortest distance.

For Viswalk, entity routing should be hard coded based on survey data or site observations. It is important to observe entity behaviour during model runs, as anomalous routing may be a sign of an error in the coding of pedestrian areas, particularly at crossings or when Levels are used to model bridges or underpasses.

3.5.2 Street Level Footways

Since pedestrians can usually access any part of a street environment, decisions must be made in the model about which areas should be available for pedestrians to use. A busy road would not be included in the usable area, so the kerbline would mark the edge of the footway space which entities could use. Less busy roads with high pedestrian flows, however, may be regularly used by pedestrians and so could be modelled as part of the usable area. Decisions should be based on site observations and all assumptions should be agreed and recorded.

In LEGION, areas where pedestrians can occupy the same geographic location but at different heights, such as bridges and underpasses, must be offset within the model. When the different levels are connected at staircases or ramps, entities are automatically moved between them if their route requires it. An example is shown in [Figure 170](#); the staircase in the centre links street level (left) to the tube station (right). The background CAD must be split into sections to account for this and consideration should be given to the layout so it is as clear as possible which levels connect and where.



Figure 170: A staircase linking levels in a LEGION model

In Viswalk each area can have a 'z' coordinate so that features can be built in their exact location. Levels may be used so that areas of different heights can be connected by stairs or ramps. In **Figure 171**, street level footways and crossings are shown in light green and the underpass, in dark green, is connected by stairs.



Figure 171: Vissim screenshot showing different levels

3.5.3 Bus Service Intervals and Dwell Times

Most TfL bus service timetables are specified by frequency rather than departure time. This, along with changing traffic conditions, means that the headways between individual buses can be variable. Buses from different routes, or even different buses on the same route, can arrive at the same stop concurrently so bus stops should be modelled to take account of this. Site observations can be used in conjunction with iBus data to understand how the stops are used by buses.

Buses on street do not have fixed dwell times at stops; the dwell time is dictated by the number of passengers that need to board or alight. However, depending on the software, it may be necessary to model a fixed dwell time. If bus capacity is known to be an issue at a particular stop then site observations should be carried out to determine if any passengers are regularly left behind.

3.5.4 Bus Stops

Behaviour at bus stops can have an impact on pedestrian movements in the area. A bus shelter will cause a width restriction of the footway at all times, but the queuing behaviour of those waiting for a bus can also cause a temporary obstruction which should be accounted for in modelling. The key points that should be observed on site are:

- Type of bus stop / shelter;
- Queuing behaviour of the people waiting for a bus; and
- Routing and behaviour of pedestrians passing the stop.

Figure 172 shows an example of a bus stop where people usually wait under the shelter and those passing the stop have to fit into half the usual footway width in order to pass it. If the number of waiting passengers regularly exceeds the capacity of the shelter then site observations should determine where the surplus passengers prefer to wait.

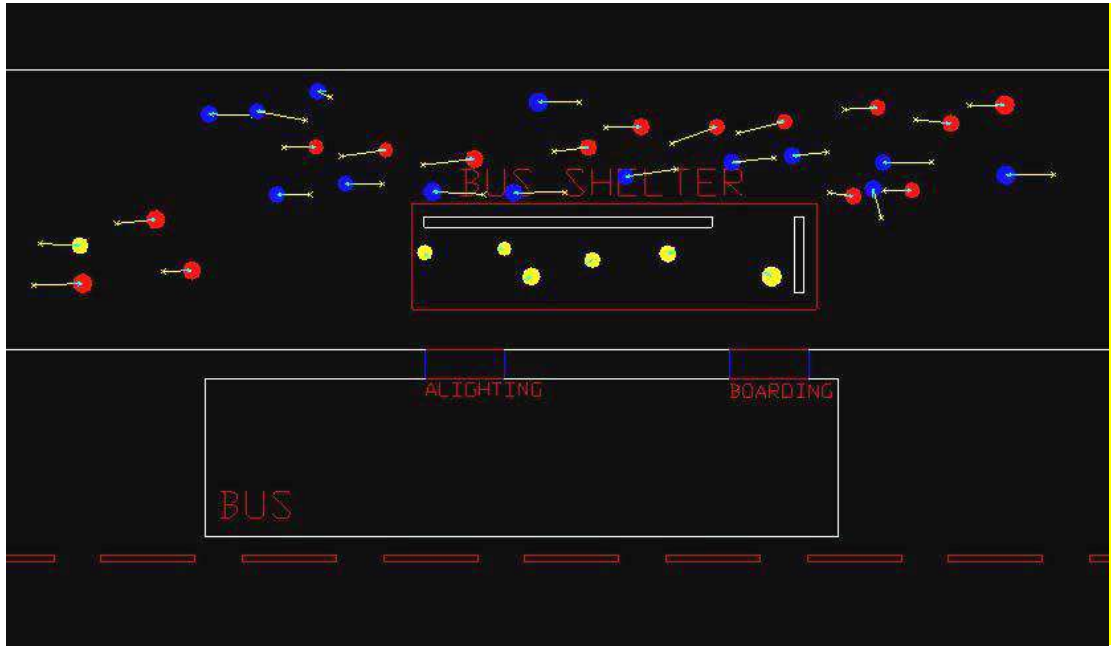

Figure 172: Example Bus Stop with shelter in LEGION

3.5.5 Pedestrian Crossings

Pedestrian crossings on street fall into four categories:

- Signalised crossings at junctions or crossings that are part of UTC-controlled groups of signals. These have a fixed or variable cycle time and the crossing can only turn green at a certain point in the cycle;
- On-demand crossings which are locally controlled. There may be a delay after the push-button is pressed, dependent on traffic levels and how recently the crossing last went green;
- Zebra crossings, where pedestrians have priority and can cross as soon as they are sure the traffic is stopping for them; and
- Informal crossings, where pedestrians cross between traffic outside designated crossing areas.

Modelling of these types of crossing depends on the software used. In LEGION the main methods are availability or delay profiles, with specific guidance in the LBPg. In Viswalk they can usually be modelled using the timings or rules that are found on street. Further detail is outlined in Chapter **B7** on **Vissim Modelling**.

For each model period, site visits should be conducted to review pedestrian behaviour, including waiting and crossing, at both formal and informal crossings.

3.5.5.1 Signalised Junctions

In LEGION, signalised junctions should be assumed to work on a fixed cycle time. The cycle time should come from plans, SCOOT messages or deterministic modelling. The minimum green that the pedestrian phase can receive can be found in the timing sheet, however, at a junction where pedestrians run in parallel with vehicles, it may receive longer. Further information on collecting signal timing data can be found in section [B2.3.8](#). The crossing timings should be modelled using availability profiles, as shown in [Figure 173](#). These can be generated with the LDT using a similar method to arrival profiles (section [C3.4.6](#)). On-demand crossings connected to a wider junction, such as those that share a controller, should also be modelled with fixed time availability profiles. LEGION only assesses pedestrian movements (not vehicles) and cannot model variable availability profiles based on demand, so the crossing is green at every opportunity for the pedestrian stage to come in.

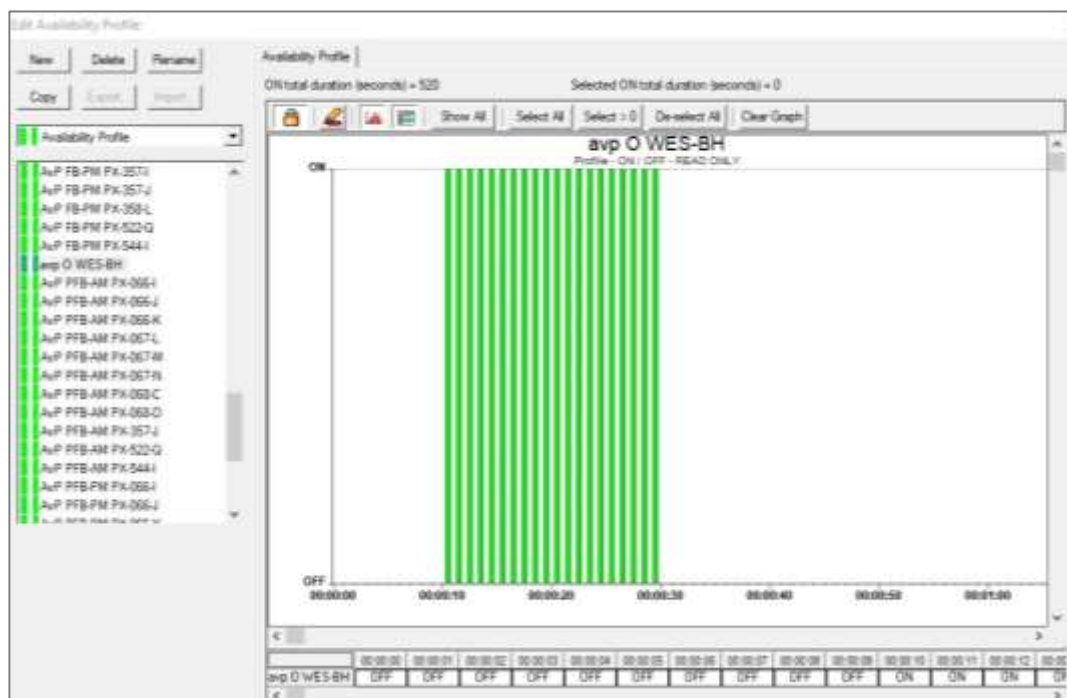

Figure 173: Availability profile for a crossing in LEGION

An example of LEGION pedestrian crossings is shown in [Figure 174](#), where three crossings meet at a central island. Direction modifiers are shown in pink and waiting areas in dark blue. Availability profiles are assigned to each of the crossing arms. Specific guidance on model objects and set up can be found in the LBPB.

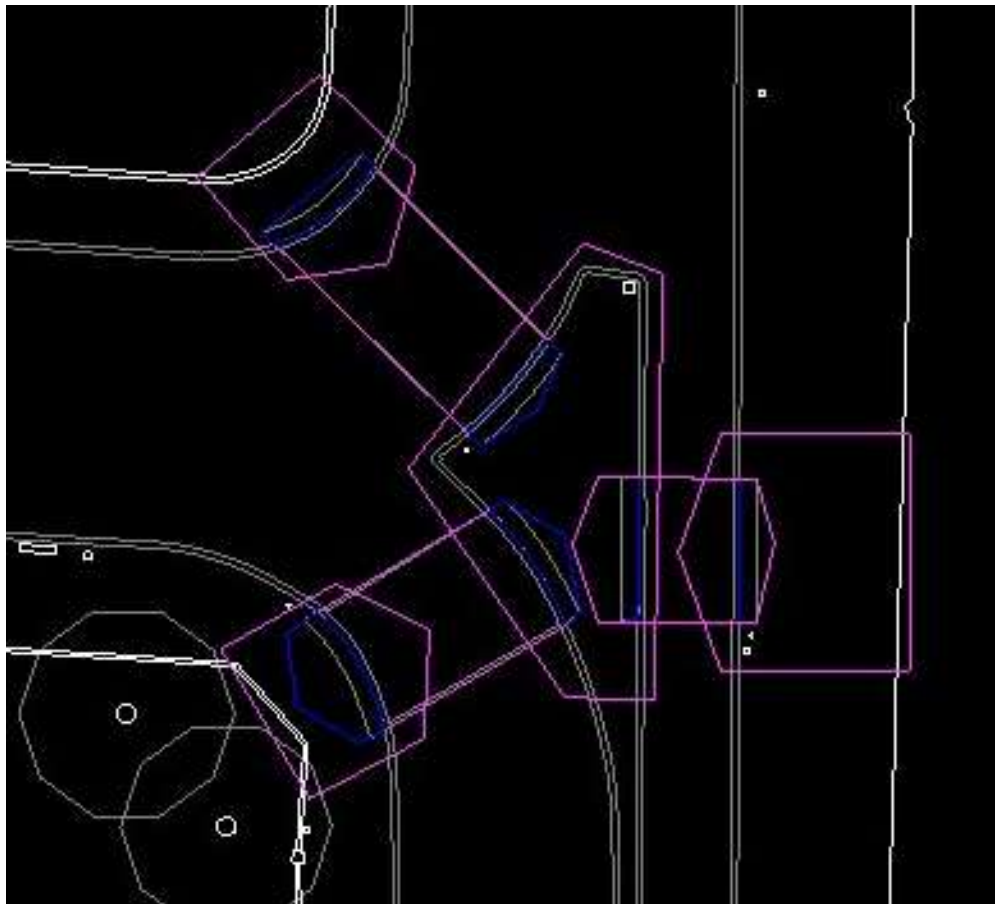

Figure 174: Example of pedestrian crossings in LEGION

UTC-controlled junctions can be modelled in Vissim using the UTC-Vissim Interface (B7.4.5.3), so any pedestrian phases should be modelled using signal heads in the same way as for vehicles. In order to apply a Signal Head to pedestrians, a Link must be used, with the 'Is pedestrian area' check box activated. Signal Heads cannot be applied to pedestrian areas directly.

It is important to ensure that the Signal Heads are applied to the Link in the correct direction on each side of the road. If the crossing is not rectangular then a pedestrian area can be used to fill in any gaps, with pedestrian links on either side to hold the Signal Heads. In Figure 175, the pedestrian Links with Signal Heads on are in a slightly darker green, with the pedestrian area which has been used to fill the gap on the left of the crossing outlined in yellow. It is important that the area does not overlap the Signal Head or pedestrians could use this area to bypass the Signal Head and get onto the crossing.

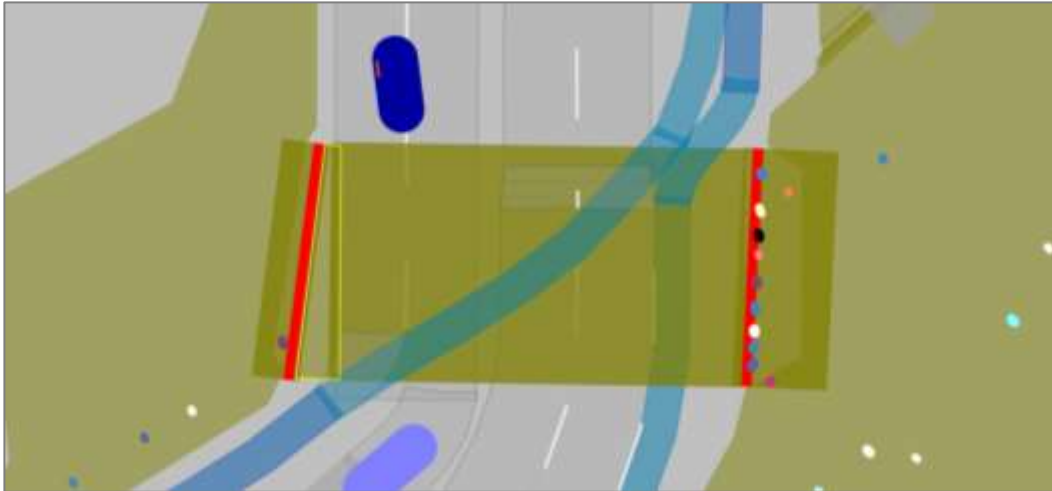

Figure 175: Signalised pedestrian crossing in Vissim

3.5.5.2 On-demand Crossings

Timings for on-demand crossings which are locally rather than UTC controlled are dependent upon the geometrical features of the junction and can be found in the timing sheet. It is necessary to check how often the crossing is called, to verify that appropriate timings are used.

In LEGION, on-demand crossings can be modelled as Zebra Crossings (section [C3.5.5.3](#)), with a delay profile representing the average amount of time between pressing the button and the green man being displayed to cross. There is no way to represent the minimum time before the signal can be green again for pedestrians, as LEGION works with fixed availability / delay profiles.

In Vissim, the same method of building crossings with signal heads and links should be used, however, since these crossings are not controlled by UTC, the signals should be controlled using VAP, as described in Chapter [B7](#) on [Vissim Modelling](#) (section [B7.4.5.1](#)).

3.5.5.3 Zebra Crossings

Although pedestrians have right of way on zebra crossings, there is usually some delay before traffic has stopped and the pedestrian decides it is safe to cross. Surveys can be conducted to determine the average delay to each pedestrian.

In LEGION this delay is modelled using delay profiles, while in Viswalk priority rules or conflict areas should be used (section [B7.4.2.5](#)). Conflict areas are quicker to apply, whereas priority rules are more flexible. Both rely on a validated traffic model so the vehicle flow is appropriate.

3.5.5.4 Informal Crossing

A certain amount of crossing away from designated pedestrian crossings is likely to occur occasionally in most areas. Usually the interaction between pedestrians and vehicles is relatively limited and impacts are negligible. Modelling any interaction between pedestrians and vehicles should be avoided outside crossings unless there is considerable delay to pedestrians (or vehicles) and it is necessary to validate the model, or where the informal crossing is regular and the level is significant. In this case NP should be consulted as to the possible and preferred methodologies which can be used to capture the impact of this crossing.

3.5.6 Validation

Base models of the existing layout with the latest available data should be validated against real life data from pedestrian surveys to ensure they replicate observed conditions to a sufficient level of accuracy.

Models should run without errors or significant warnings before validation is attempted.

A model should be validated to:

- Provide evidence that it reflects the on-street conditions;
- Give confidence to stakeholders, including public consultations, that the modelling can be trusted; and
- Provide a basis to build Proposed models.

Base models should be validated using real-life data collected through surveys. Data used for model validation should be agreed at the MAP Stage I meeting (section [B2.1.5.1](#)).

For information on LEGION modelling refer to the LBPG where there is specific guidance on validation criteria. Key assumptions which differ from TfL standards should be referred to in the project-specific Modelling Expectations Document (section [C3.4.1](#)) for agreement early in the process.

3.5.6.1 Randomness

Exact conditions on street vary day-to-day as a result of random pedestrian behaviours such as speed and route choice, and also as a result of external factors such as the weather. Dynamic pedestrian models attempt to replicate this day-to-day random variability by altering individual pedestrian decisions based on random numbers. The set of

random numbers is generated from an initial seed value specified at the start of a simulation run. A single set of random numbers, generated by a single seed value, therefore represents one potential outcome, or one particular day of pedestrian movements. The actual value of the seed has no significance; however, the seeds from different runs must be different from each other to produce different outcomes. Basing results on a single seed value has the potential to randomly bias the overall result.

An accepted method of reducing potential bias is to run several simulations using a range of initial seeds and to present mean average results. For this reason, both calibration and validation should be conducted using at least 5 seed values.

Ideally any on-site surveys would be carried out over multiple days to mirror the number of seeds, however this is often not possible. Where surveys are carried out on a single day, observations should be conducted to ensure the conditions are considered typical and unaffected by significant disruption. These observations can be backed up by analysis of background data, including signal control data and incident records. This checking reduces (or highlights) potential bias in the observed data and provides reassurance that it can be used to validate average results (or an indication that the data collection exercise should be repeated on a more typical day).

All seed values used should be included in the report. 'Cherry picking' seed values biased toward validation targets is not acceptable, so any seed values chosen which are replaced because they cause blocking must be noted. Results from the different runs will ideally be relatively consistent. One method of testing this consistency in LEGION is to look at the social cost value for each run (section [C3.6.4](#)). Typically, the difference in social costs between model runs is around 2%. If this is not the case, then more runs should be carried out to ensure a robust average.

Where possible the same seed values used in Base models should be carried over to Proposed modelling runs.

3.5.6.2 Requirements

Pedestrian flows should be validated by comparing the OD Matrix against entry and exit counts in the model to ensure the correct number of pedestrians are present. It is also necessary to include pedestrian flow counts at key locations, such as crossings and important footways, in the flows that are compared. Although validation criteria may differ between projects depending on the data available, in general, pedestrian flows should be within 5% of the expected values.

Pedestrian journey times on key routes should be recorded from models and compared to real world values. The routes that are used should be agreed between all stakeholders. The simulated journey times along these routes should be within 10% of surveyed journey times.

An important part of validation is ensuring that model behaviour replicates on-street behaviour. Visual validation should be carried out by comparing model movements with observations on site to ensure they are realistic and representative of real-life behaviour. Any unrealistic entity movement or blocking should be eliminated as far as possible.

3.5.7 Proposed Models

As is outlined in section **B2.5**, the Proposed model should be implemented in the Base model (or Future Base model if the Three Stage Modelling Process is being followed, section **C3.5.7.1** below) by only modifying elements which will change as part of the scheme, including any signal timing changes. Adjusting other elements, which will not change on street, 'to make it work better' is not acceptable. If the Proposed model will not work without additional changes then this is a sign that either the proposed design is not viable or the Base model was not fit for purpose and should be revisited.

This section deals with aspects which particularly need to be considered when building a Proposed pedestrian model. For a more general overview refer to section **B2.5**.

3.5.7.1 Future Base

The Future Base model bridges the gap between Base and Proposed scenarios and provides a reference when analysing the Proposed results. As described in section **B2.5.1**, the Future Base model includes all likely on-street changes which will occur between the Base year and the year being examined in the Proposal, excluding the scheme under consideration. When applied to pedestrian modelling, this will normally only involve

changes in pedestrian flows. Flows are adjusted to reflect demand changes from Buses, LU, predicted background demand and any other schemes in the area. Public Transport demand changes should be agreed with the scheme Promoter and M&V and based on knowledge of the area and relevant supporting data. Predicted flow changes from nearby schemes can be found in the transport assessment for each scheme or informed from the scheme Promoter or M&V.

3.5.7.2 Proposals

Proposed models should be built in the Base (or Future Base) model whilst changing as little as possible. The main changes that will be required are to the layout, signal timings and flows. The new layout should come from proposed CAD drawings which should include as much detail as possible on street furniture and footway and crossing widths. Any changes to signal timings can be transferred from other traffic modelling work being carried out for the scheme.

The flow changes that are introduced at this point should be those that are a direct result of the scheme. Depending on the type of scheme, these flow changes can be sourced from different locations:

- Changes to public transport, for example new bus stops or changes in bus routes, come from Public Transport Service Planning (PTSP) within TfL;
- Estimated demand generated by a new development would be provided by the transport assessment from the developer or City Planning; or
- If the scheme only involves layout changes to the road or pedestrian space then there will usually be no changes to Base (or Future Base) flows.

In LEGION, this new routing can be implemented by adding any new entries and exits that are required and updating the OD matrix. In Viswalk, some assumptions may be required about the route choice of any additional demand.

3.6 Model Outputs and Analysis

In any scenario where pedestrian impact assessment is deemed necessary, the following outputs should be considered:

- Crowding levels;
- Journey times; and
- Social costs (including generalised journey times and congestion factors).

In addition, there are various visual outputs which can be used to demonstrate modelling results and scheme operation.

Table 19 summarises the different modelling methods that are required for each type of output. They are explained further in the rest of this section.

Table 19: Modelling methods required for different output types

Output Type	Data	Static Assessment	Dynamic Modelling
Analysis	PCL	PCGL Spreadsheet	
	Counts	PCGL Spreadsheet	LEGION / Viswalk
	Density / Space utilisation maps		LEGION / Viswalk
	Journey times	TfL Spreadsheet	LEGION / Viswalk
	Generalised journey times / Congestion factors		LEGION / Viswalk
	Social costs		LEGION
Visualisation	Simulation screenshots / videos		LEGION / Viswalk
	Integration with Vissim		Viswalk
	3D visualisations		Viswalk

3.6.1 Crowding Levels

When assessing a pedestrian environment, a key output is how busy or congested that environment becomes under certain defined conditions. It is very important to consider how much space and comfort a pedestrian will experience as part of changes to the street and surface level layout. The two most widely used measures of pedestrian experience at TfL are Fruin Levels of Service (LoS) and Pedestrian Comfort Levels (PCL).

3.6.1.1 Fruin's Levels of Service

Fruin's Levels of Service¹³⁷ were developed in 1971 to give an idea of crowding levels in pedestrian areas. They are one of the outputs from pedestrian modelling software and are commonly used when assessing the performance of a scheme for pedestrians. They are particularly useful when displayed as plots, as is explained in section [C3.6.2](#).

The LoS are based on the amount of space available to each pedestrian at any given moment. The LoS for a particular area of walkway is usually a result of averaging the levels for that area over a 15-minute period. There are different thresholds for walkways, stairs and queues which are summarised in [Figure 176](#).

¹³⁷ Fruin, J, *Designing for Pedestrians: A Level-of-Service Concept*, The Port of New York Authority, 1971

Level of Service	Persons per square metre (Walkways)	Persons per square metre (Stairs)	Persons per square metre (Queues)	Visual Indication (Walkways)	Description (Walkways)
A	< 0.31	< 0.54	< 0.83		Free movement
B	0.31 – 0.43	0.54 – 0.72	0.83 – 1.08		Free movement with only minor conflicts
C	0.43 – 0.72	0.72 – 1.08	1.08 – 1.54		Slightly restricted movement and difficulty passing. Bi-directional flow possible.
D	0.72 – 1.08	1.08 – 1.54	1.54 – 3.59		Restricted movement. Bi-directional flow difficult.
E	1.08 – 2.15	1.54 – 2.69	3.59 – 5.38		Restricted movement. Intermittent stopping. Bi-directional flow very difficult.
F	> 2.15	> 2.69	> 5.38		Breakdown in movement with many stops.

Figure 176: Fruin's Levels of Service for walkways, stairs and queues

3.6.1.2 Pedestrian Comfort Levels

PCLs were developed as a result of research commissioned by TfL which aimed to use new methodologies to understand pedestrian comfort. The research built on and updated LoS and provided a new set of levels which are tailored to the area types found on London's streets. The full list of PCLs is shown in **Figure 177** and a table defining how these levels are applied to different area types can be found in the PCGL document¹³⁸. Further information on how PCLs are measured and applied can also be found in this document, which includes a spreadsheet containing the calculations. The document outlines the process step-by-step and recommends the appropriate levels of comfort by area type, including at pedestrian crossings and on crossing islands. It also provides insights into the surveys on pedestrian behaviour that went into developing the levels.

In contrast to LoS, which work on an area-based estimation of how much space each pedestrian has, PCL is a more time-based measure of people per metre per minute (ppmm) walking along a footway. This allows surveys of pedestrian flows past a point to be used to calculate the comfort levels, which makes them easy to use. The Restricted Movement column in **Figure 177** refers to the percentage of people who had to change their speed or route, or who brushed against or bumped into someone else.

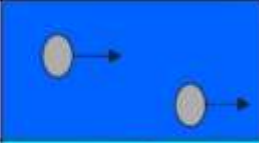
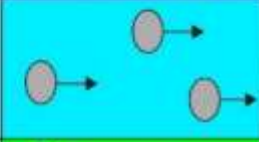
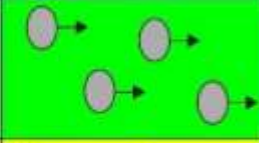
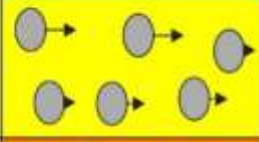
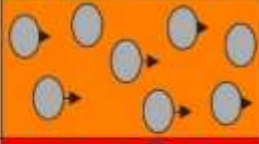
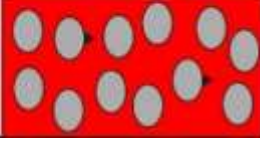
When applying PCLs to future scenarios, measurements can be made from dynamic modelling or recommendations can be made based on flow rates and widths or accessible space in the proposed design.

¹³⁸ Pedestrian Comfort Guidance for London – Guidance Document, Version 2, Transport for London, 2019, accessible at <http://content.tfl.gov.uk/pedestrian-comfort-guidance-technical-guide.pdf>











PCL	ppmm	Restricted Movement	Visual Indication	Description
A+	< 3	< 3%		Very comfortable environment where pedestrians have enough space to walk at the speed and route they choose.
A	3 – 5	13%		
A-	6 – 8	22%		
B+	9 – 11	31%		B+ is the recommended level for all area types. At B and B- normal walking speed is possible, but conflicts are more frequent and pedestrians are less comfortable.
B	12 – 14	41%		
B-	15 – 17	50%		
C+	18 – 20	59%		Environment is increasingly uncomfortable with frequent conflicts and bi-directional movement becoming difficult.
C	21 – 23	69%		
C-	24 – 26	78%		
D	27 – 35	100%		Walking speeds are restricted and overtaking is difficult.
E	> 35	100%		Very little personal space with speed and movement extremely restricted.

Figure 177: Pedestrian Comfort Levels

Table 20 shows an example of how the PCLs are applied to the pedestrian experience on a high street, which is one of the area types (the full table can be found in PCGL). It also gives an indication of how the levels relate to Fruin LoS thresholds.

Table 20: PCLs related to high street pedestrian experience and Fruin LoS for walkways

PCL scale	ppmm upper limit	Restricted movement	High Street suitability	LoS walkways scale
A+	<3	<3%	Comfortable	A
A	6	13%	Comfortable	A
A-	9	22%	Comfortable	A
B+	12	31%	Comfortable	A
B	15	41%	Acceptable	A
B-	18	50%	At Risk	A
C+	21	59%	Uncomfortable	A
C	24	69%	Uncomfortable	B
C-	27	78%	Uncomfortable	B
D	35	100%	Uncomfortable	CDEF
E	>35	100%	Uncomfortable	CDEF

3.6.2 Plots

Calculations as part of a dynamic assessment are able to provide a level of understanding of how conditions at street level might look. This is achieved by incorporating non-linear flow events, such as the arrival of a bus, and taking into account how flow rates may be affected as conditions become more congested. Pedestrian modelling software provides the facility to output heat map style plots for a variety of different datasets. Heat maps are based on flow rates and widths or areas of accessible space. The maps usually reflect differing LoS (section [C3.6.1.1](#)), which can be applied to different assessment conditions; walkways, stairways and queuing areas. Different LoS categories can be represented in a single plot, however, this usually only involves walkways and stairs as these areas can be easily differentiated. Walkways LoS and queuing LoS should not be shown in the same plot as it may be hard to determine which areas the different scales apply to. Queuing LoS plots are rarely produced and should only be used if there is a particular project requirement. Plots

should clearly identify which LoS have been used and which areas they apply to.

Plots are output from one model run, so once the modelling results are finalised using multiple runs with different seeds (section [C3.5.6.1](#)) the run that is nearest to average is chosen to produce the plots.

The plots to be produced should be agreed with stakeholders in advance of the analysis, however, the main plot would usually cover the busiest 15-minutes in the modelled period, as defined by the total number of people in the model. Plots of the other three 15-minute periods in the peak hour should be provided in report appendices. Different types of plots, such as the Cumulative Mean Density and Cumulative High Density plots detailed below, should cover the same time periods so their information can be directly related.

3.6.2.1 Cumulative Mean Density

A commonly used plot is the Cumulative Mean Density (CMD) plot, which displays the mean level of density in an area over the specified period. Plots are usually coloured according to the Fruin LoS, although a legend should be included to explain the colour scheme. The average calculation only includes time that the area is occupied, so areas which occasionally experience extremely high levels of activity will show as higher up the scale than areas with constant low levels of movement. This helps to highlight any crowding problems which may be caused by irregular events such as waiting for crossings or buses arriving, as well as any areas which are constantly busy. Smoothing should not be applied to CMD heat maps.

Figure 178 shows an example where the highest level is at the waiting area for the crossing in the bottom right. The crossing areas are also busy, where pedestrians from both sides meet and walk past each other.

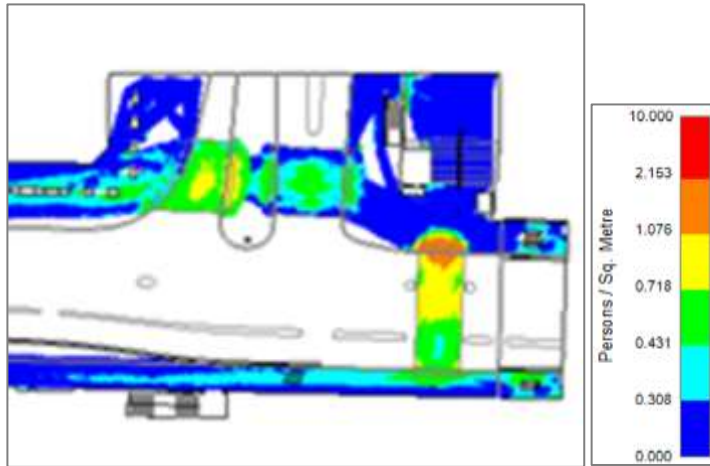

Figure 178: Example heat map showing Cumulative Mean Density, with Fruin's LoS for walkways

3.6.2.2 Cumulative High Density

Cumulative High Density (CHD) plots take a given density level and are coloured according to how much time is spent above that value. A white-pink-purple colour scheme is recommended, with the darker colours used for areas with longer times spent above the threshold. These plots are useful for highlighting areas which are constantly at a high density.

The CHD density level used for most projects will be time spent above 1.08 persons per square metre. This is the threshold for exceeding LoS D on walkways, LoS C on stairs and LoS B on queuing areas. **Figure 179** shows an example which has the darkest areas at the waiting areas for crossings, in particular in the bottom right, where the footway is narrow.

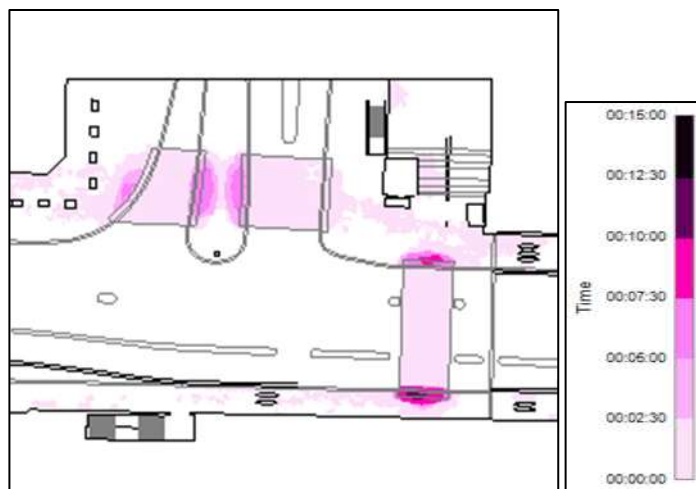

Figure 179: Example heat map showing Cumulative High Density: Time spent above LoS D using Fruin's LoS for walkways

3.6.2.3 Space Utilisation

Although not a required output, space utilisation plots can be useful for identifying shortest routes that pedestrians prefer to take. This information can be used to identify locations where it would be beneficial to locate signage and where it would be better not to put street furniture to minimise obstacles to pedestrian journeys. Colours in the plots represent how often the space is used within the relevant time period, with brighter colours representing longer times. **Figure 180** clearly shows the used areas in blue with highly used desire lines in green / yellow and congested areas in red.



Figure 180: Space utilisation plot

3.6.3 Journey Times

Journey times, or the times taken for pedestrians to walk between two points, are another key output of pedestrian modelling. Due to the nature of the output, journey times are normally only derived from dynamic modelling, although the spreadsheet tool mentioned in section **C3.3.1.3** can produce a simplified crossing time based on the signal delay.

Pedestrian models can be analysed to give a walk time for a single pedestrian making a defined movement, or an average for all pedestrians that are making that movement. Journey times can be used to help validate models, by comparing model walk times with those observed from surveys. They also are valuable in assessing the performance of different options against the Base or Future Base scenario.

3.6.4 Social Costs

Social costs assign a monetary value to pedestrian journey times, which enables cost comparisons to be made between different layouts and options. These comparisons can be used to support scheme assessments and are a key output from dynamic modelling.

To calculate social costs, pedestrian journey times need to be broken down into separate elements that include walking, waiting, queuing, walking on stairs, and travelling on escalators. Each element has a weighting applied to it based on how desirable that element of the journey is to the pedestrian, walking upstairs has a weighting of 4.0, whereas travelling on an escalator has a weighting of 1.5, for example. This method of applying a weighting to each element of a pedestrian journey time gives an output that is known as a generalised journey time.

In addition to the production of generalised journey times, a value known as the congestion factor is calculated by pedestrian modelling software. This congestion factor represents the perceived cost of delays to a pedestrian's journey due to crowded conditions.

The sum of appropriate generalised journey times and congestion factors gives the social cost. The latest weightings for journey times and congestion factors can be found in the TfL Business Case Development Manual (BCDM) data book. This can be obtained by contacting StreetsPedestrianModelling@tfl.gov.uk.

Social costs can also be represented annually by estimating the number of journeys over a calendar year, calculating the costs and then multiplying them by the number of working days over the year.

3.6.5 Screenshots and Videos

A key benefit of dynamic modelling is the ability to observe entities move through the model, and thus give a deeper understanding of how future layouts might operate. Screenshots can be taken at any point within the model to illustrate a point of interest, and can be a useful tool when reporting on key findings.

Dynamic models are based around the interactions between pedestrians and their environment. During model calibration, simulations are particularly useful to see issues which may not be picked up statically, for example, pinch points or safety concerns. Once the model has been finalised, pedestrian modelling software can generate 2D or 3D videos which can be used to visually demonstrate the pedestrian movements. These videos are very helpful in scheme consultations and provide an

excellent visual aid when presenting the performance of complex scheme designs to a non-technical audience, for example, **Figure 181** shows pedestrian movements along a pedestrianised street.

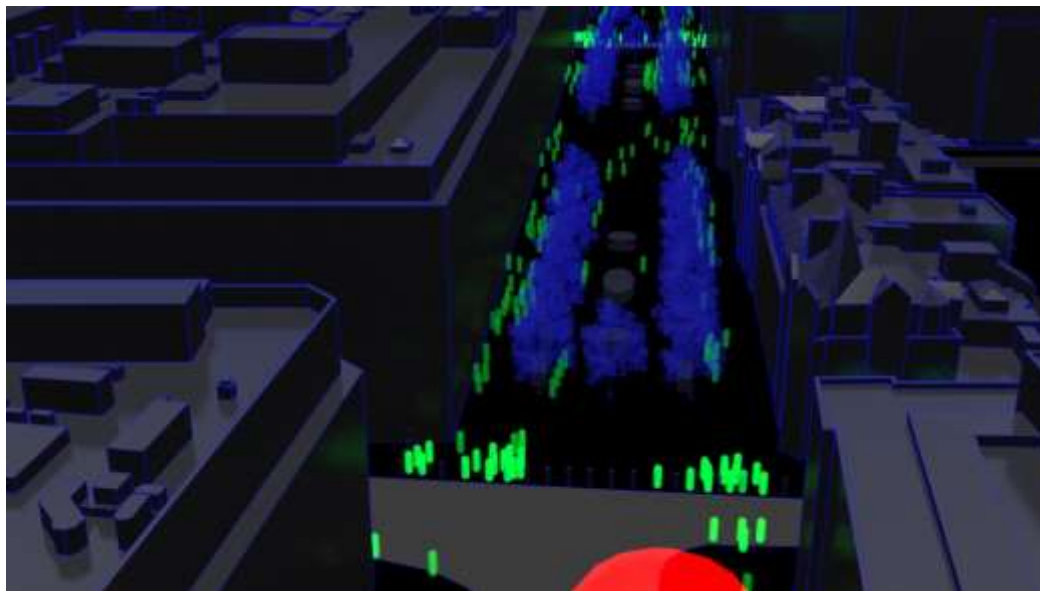

Figure 181: Modelled pedestrians in a 3D scene

4 Emissions Modelling



4.1 Introduction

Air pollutants are substances in the air that can harm human health and affect quality of life. The Mayor's London Environment Strategy¹³⁹ details the specific challenges surrounding air quality and the measures which are planned to overcome them. Air pollution causes thousands of Londoners to die sooner than they should (estimated over 9000 Londoners died prematurely from long-term exposure to air pollution in 2010¹³⁹). Children, the elderly and people already suffering from pulmonary or cardiovascular disease are particularly vulnerable. In order to tackle these issues, the London Environment Strategy aims to reduce car use and switch to cleaner fuels to ensure that London's transport system is zero emission by 2050. It also prioritises reduced air pollution at locations such as schools, nurseries, care homes and hospitals.

Road transport contributes significantly to the emission of air pollutants in London¹⁴⁰. Air pollutants from transport sources can broadly be divided into two categories:

¹³⁹ London Environment Strategy, Greater London Authority, May 2018. Can be accessed at <https://www.london.gov.uk/what-we-do/environment/london-environment-strategy>

¹⁴⁰ Air Quality Team, *London Atmospheric Emissions Inventory 2016*, Greater London Authority, 2019

- Pollutants that have an impact on local air quality and human health. The most significant of these pollutants, and the focus for TfL, the GLA and London boroughs include the following:
 - **Nitrogen dioxide (NO₂)** – NO₂ is mainly formed in the atmosphere from nitric oxide (NO) emitted by road vehicles, but it is also emitted directly. By convention, the sum total of NO and NO₂ is termed 'nitrogen oxides' (NO_x).
 - **Airborne particulate matter** – Different classifications are used to describe particulate matter according to their physical characteristics¹⁴¹, the most common being PM₁₀ and PM_{2.5}; and
- Greenhouse gases, which have an effect on the global environment. The most important of these, due to the total volume of production, is carbon dioxide (CO₂). Other pollutants, such as methane (CH₄) and nitrous oxide (N₂O), are stronger greenhouse gases but are emitted in smaller quantities and are not a focus for TfL.

The emissions produced by road traffic are influenced by a large number of factors including vehicle type, fuel type, vehicle age, driving behaviour, traffic conditions and road gradient. Hence the accuracy of emissions estimates depends on which of these factors are used as input information and the quality of the data behind them.

The most widely used approach to estimate road traffic emissions is based on the type of vehicle and its average speed on a section of road (further information can be found in section [A4.5.6](#)). This approach can be used with outputs from deterministic or tactical models, however, since these do not produce the second-by-second data of an individual vehicle it cannot capture the emissions produced as a result of the instantaneous acceleration of the vehicles. Hence, this approach may not estimate the emissions very accurately in an urban environment, where a lot of stop-start actions take place. In such areas, detailed emissions modelling using an instantaneous emissions model should be used when emissions need to be estimated more accurately. Microsimulation traffic models are needed to provide the detailed individual vehicle outputs needed for use by an instantaneous emissions model. This chapter focuses on this type of detailed emissions modelling.

141 PM₁₀ and PM_{2.5} relate to particulate matter with a diameter of less than 10µm and 2.5µm respectively

4.1.1 Scope

This chapter provides details on the methodology and requirements which were defined as a result of the Putney High Street study described below. It includes guidance on the estimation of vehicle emissions with purpose-built emissions modelling software, using the individual vehicle data collected from microsimulation models. Details are provided on the modelling methodology, including the parameter inputs required for both the emissions and microsimulation software, and the additional considerations for microsimulation modelling when used for emissions outputs. There are also sections on specifically how this is applied when using the commercially available software packages EnViVer (section C4.3) and PHEM (section C4.4).

Although vehicle emissions contribute to the air quality of an area, this guidance does not attempt to cover air quality modelling since it is dependent on many factors other than localised vehicle emissions. Detailed air quality models therefore require increased complexity involving other relevant sources of air pollution, dispersion modelling and environmental science expertise.

Meeting specific objectives is necessary for the success of any scheme. However, it is equally important that scheme designers, modellers and traffic engineers consider wider strategic transport objectives. This chapter provides a point of reference to the modeller when considering an approach to road traffic schemes that incorporate emissions studies as part of the air quality and environmental assessment requirement.

4.1.2 Case Study

A study was carried out around Putney High Street in south west London in 2017 and 2018. The area is well known for poor air quality attributed to the traffic and local topographic features. Putney High Street is a narrow road with tall buildings on either side creating a canyoning effect which causes emissions to disperse more slowly. It also has a high number of junctions in a short distance so, prior to the study, traffic moved slowly through the area and there was a lot of stop-start queuing behaviour which generates more emissions than free-flowing traffic. This combination of features, together with the large number of pedestrians in the area, meant that it was necessary to implement measures to improve the air quality. Although it is hard to measure a direct link as air quality is dependent on many factors, reducing vehicle emissions in an area has a positive impact.

The aim of the study was to explore the use of a traffic signal gating strategy to influence vehicle emissions. The control strategy was

developed by the corridor manager for the area, as they had the local knowledge necessary and would be responsible for implementing the timings on street. Signal timings were adjusted to decrease green times into Putney High Street so northbound queues were held on Putney Hill, an open area with fewer pedestrians, and away from the busy shopping area.

In order to investigate the impacts of this study in a simulated environment and test out different signal timing scenarios, microsimulation modelling of the area was carried out. This was used to check that the measures did not cause too much disruption to buses in particular, but also to general traffic. Since the goal of the measures was to reduce vehicle emissions in the target area, the modelling was also used to verify that this was achieved. Outputs from the microsimulation model, containing vehicle speeds and accelerations every second, were used as an input to the emissions model and the emissions results were reported based on the two defined areas of Putney High Street and Putney Hill. The results were also verified against on-street data using the second-by-second records from the iBus system, which could also be used as an input to the emissions software.

In addition to traffic and emissions results, the objectives of the modelling project were as follows:

- There was no history of emissions microsimulation modelling at TfL, so it was necessary to develop a methodology which could be used in future projects;
- Emissions modelling has a requirement for a vehicle fleet composition to be defined in terms of fuel types and engine standards, so this information needed to be collected for London; and
- To investigate any additional requirements in terms of data and microsimulation modelling techniques.

The remainder of this chapter details the results of these objectives.

4.2 Methodology

The methodology adopted in this guidance is based on the combination of a microscopic traffic simulation model (such as Vissim or Aimsun Next) and a microscopic emissions model (for example PHEM or EnViVer). In this process, the traffic model simulates individual vehicles and their interactions using model parameters such as flows, speeds, junction control, and vehicle types. The behaviour and positions of these individual vehicles are captured in output files, which are used as inputs for the emissions model to estimate resulting emissions. This approach takes the speed / acceleration of a vehicle into account at discrete time intervals when estimating emissions. An example speed profile for one vehicle is shown in **Figure 182**.

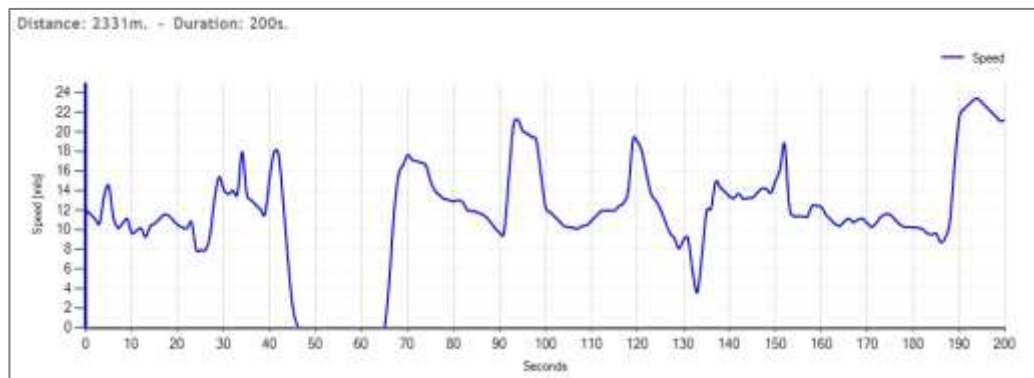

Figure 182: Speed profile of a vehicle

This type of model can therefore better account for the influence of congestion upon emissions levels than a deterministic or tactical model. The broad methodology is shown in **Figure 183**.

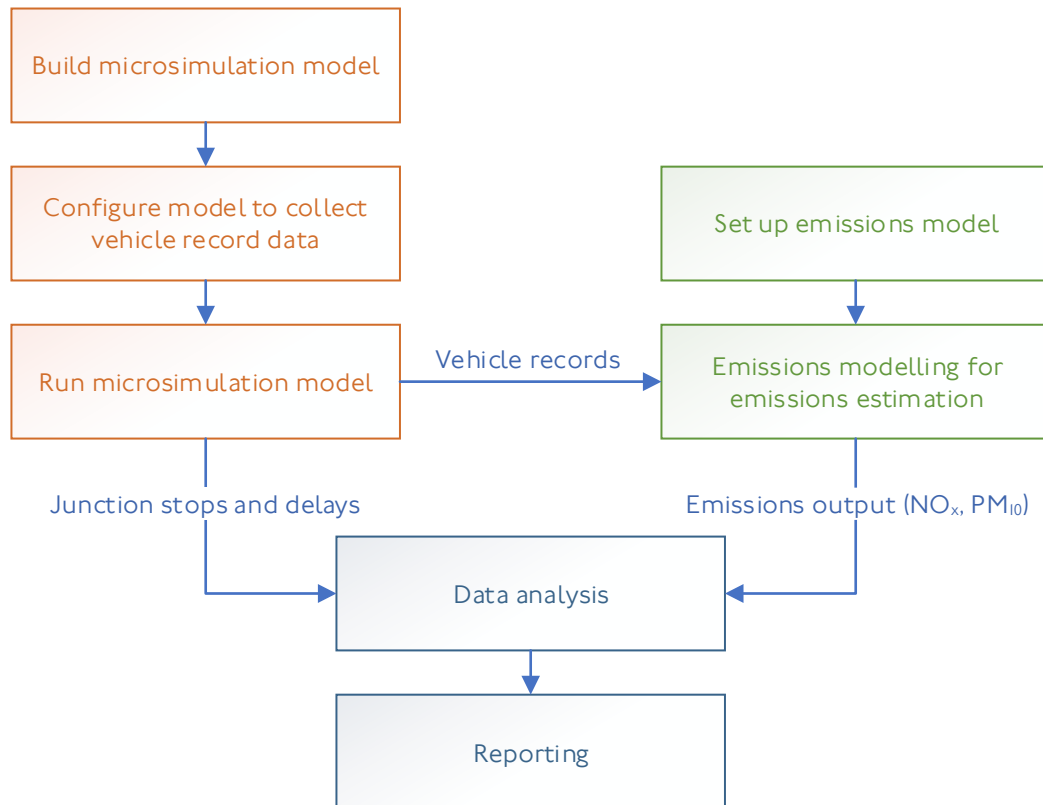

Figure 183: Emissions modelling process

As with most types of modelling, emissions modelling will usually be carried out to compare scenarios, either Base and Proposed or various Proposed options. The differences between these scenarios will be in the microsimulation model only; the emissions model fleet parameters should remain the same for all scenarios to ensure a fair comparison, unless a change in fleet composition is expected as part of the Proposed scenario.

4.2.1 Microsimulation Modelling

Microsimulation modelling is usually carried out to compare different scenarios with relation to a particular objective, for example reducing bus delay or improving cycle safety, where the network is too complex or congested for a simpler type of modelling. If the objective is to study detailed emissions outputs, then microsimulation modelling is used as a source of the individual vehicle data which is an input to emissions modelling.

The microsimulation software packages covered in these Guidelines are Vissim (in Chapter **B7** on **Vissim Modelling**) and Aimsun Next (in Chapter **B3** on **Aimsun Next Modelling**), and these chapters should be referred to for specific guidance on building the microsimulation models. The decision to undertake emissions modelling should be made at MAP Stage I as there are

specific data requirements which must be determined before modelling commences.

4.2.1.1 Model Boundaries

Modelling should cover the area of influence, which is the area where it is anticipated that the proposed measure will have an effect, rather than just the area where the proposal is implemented.

4.2.1.2 Vehicle Types

As the emissions characteristics of vehicles differ from each other (even for the vehicles having the same PCU factor), vehicles with different emissions characteristics should be categorised separately as far as possible, depending on the level of detail required in the outputs. For example, cars, taxis, LGVs, rigid and articulated HGVs, single-decker and double-decker buses and coaches can be modelled as different vehicle types. The relevant manual for the emissions software being used should be consulted to determine the vehicle classifications. Some of these classifications, particularly the difference between car and LGV, are not counted separately during a standard survey, so if they are required it should be determined at MAP Stage I. The fuel type and Euro engine standards are taken into account at the emissions modelling stage (section [C4.2.2](#)) and do not need to be separately considered in the microsimulation modelling.

4.2.1.3 Vehicle Dynamics

Vehicle emissions are greatly influenced by the dynamics of vehicles (acceleration and deceleration) hence the parameters used in a microsimulation model should reflect the characteristics of the vehicles in the network. Empirically derived vehicle dynamics values, based on the observed data, should be used if possible. In the absence of such data, default values from the relevant TfL microsimulation template may be used. If there is any doubt about the default values, the vehicle acceleration output can be checked by plotting the acceleration (every second) of a sample of vehicles to see if it looks sensible.

4.2.1.4 Road Gradient

Road gradient affects the amount of energy needed for a vehicle to travel through a road section and therefore the power output and emissions from an engine. For example, queuing traffic accelerating away from a traffic signal emits more emissions if pulling away on a steep uphill slope

than on a downhill approach. Therefore, as far as possible, road gradient should be taken into account when estimating emissions.

The gradient is specified as the percentage of altitude difference per unit length of a road section. The altitudes of both ends of the road section can be obtained from sources such as Ordnance Survey data or Google Earth. With the known length of the road section, the average gradient is calculated as:

$$\text{Gradient} = \frac{\text{Altitude of downstream point (m)} - \text{Altitude of upstream point (m)}}{\text{Length of the section (m)}} * 100 \%$$

In this case, a positive value relates to an uphill gradient and negative means downhill.

If no road gradient is used in a microsimulation model, the output text file could still be edited to include the road gradient if needed for an emissions model. If no road gradient is provided, the emissions calculation will be based on the assumption that the roads are flat (0% gradient).

4.2.1.5 Model Calibration and Validation

The microsimulation models used for emissions modelling should be developed and audited following MAP. The decision to undertake emissions modelling should be taken at the start of the process, in MAP Stage I, so the scope of the model and the validation criteria can be set in order to capture the detailed output data which will be used for emissions modelling. The **Aimsun Next Modelling** and **Vissim Modelling** chapters (**C3** and **C7**) contain more information on calibrating and validating microsimulation models.

Vehicle emission outputs themselves cannot be validated without detailed data collection on tailpipe emissions from vehicles. Fixed air pollution measurements are dependent on many other factors and so roadside emissions collection cannot be used. This means emissions predictions are highly dependent on accurate vehicle behaviour in the original microsimulation model. Some typical modelling practices, such as using RSAs to account for high street friction, might not accurately capture repeated stop-start behaviour, so more effort should be made to model the reasons behind any changes of speed, so the behaviour is represented accurately.

4.2.1.6 Model Output Configuration

Emissions modelling requires individual vehicle trajectory data, including position, speed and acceleration. The microsimulation model needs to be configured to collect this vehicle trajectory data into a vehicle record file. This data gives information about the state of each vehicle in a network at every second. The requirements for the vehicle record output might be slightly different depending on the emissions model used.

In Vissim, the main network element is a Link and in Aimsun Next it is a Section. For emissions modelling, the grouping of the Links or Sections to form Segments is done to reduce the analysis burden of data processing. A Segment is a group of one or more Links / Sections with similar characteristics in terms of the scheme impact, usually grouped by location. Note that this is not the same as a Segment in Aimsun Next. Segment IDs can either be allocated in the microsimulation software, via some kind of naming convention, or added to the output files later. In order to conduct proper analysis, each Segment must have a unique ID.

To collect the appropriate data, the following items need to be configured in the microsimulation model outputs:

- Vehicle types: as described in section [C4.2.1.2](#), all types of motorised vehicles producing emissions should be selected to generate output;
- Links / Sections: as described in section [C4.2.1.1](#), all Links / Sections in the area of interest should output data;
- Time resolution of data collection: should be set to one second for compatibility with common emissions modelling software; and
- Vehicle parameters data collection: at a minimum, the parameters selected for output should include:
 - Simulation Time;
 - Vehicle ID;
 - Vehicle Type;
 - Speed;
 - Coordinate X;
 - Coordinate Y;
 - Link / Section / Segment ID; and
 - Gradient, if available.

4.2.1.7 Running the Model

As with all outputs from microsimulation, it is recommended to carry out 20 simulation runs with differing random seeds in order to produce a range of results. More information on running microsimulation models can be found in the relevant sections for Vissim (section [B7.5.1](#)) and Aimsun Next (section [B3.5.1](#)). Depending on the emissions software used, the results can be combined and averaged before, during or after the emissions modelling process.

4.2.2 Emissions Modelling

In a microsimulation model, different vehicles with similar traffic characteristics (for example the same PCU value) may be grouped into one vehicle type. However, the vehicles within a vehicle type may be different in terms of other characteristics, such as fuel type and Euro engine standard, which will affect the level of emissions produced. For an accurate estimate of emissions using traffic model outputs, the proportions of vehicles with different characteristics within a vehicle type need to be inputs to the emissions model. Such proportions should be based on observed data, although existing London-wide proportions can be used if the precise vehicle types were not recorded during surveys.

The emissions software covered in this document calculates instantaneous vehicle emissions on a second-by-second basis, so the appropriate use is to carry out detailed emissions modelling using second-by-second vehicle data. For example:

- vehicle trajectories from a microsimulation model;
- any second-by-second automatic vehicle tracking data recorded from site, for example, appropriate GPS data or London's iBus system; or
- vehicle trajectories collected using an instrumented vehicle, for example floating car data.

The software links this data to an emissions model for estimation of CO₂, NO_x and PM₁₀ emissions. The emissions calculations are based on the speed-time profiles of the vehicles.

4.2.2.1 Fuel Types

The emissions produced from a vehicle are heavily influenced by its fuel type, namely: petrol, diesel, electric or hybrid. Hence, the proportion of these fuel types should be input and, as already mentioned, this will usually come from London-wide data.

4.2.2.2 Euro Engine Standards

The Euro engine standards are regulations across the EU and EEA member states which define acceptable limits for exhaust emissions of new vehicles. These standards have become stricter over the years so vehicles complying with the latest Euro standard produce far less emissions in comparison to their predecessors. For light vehicles, the standards range from Euro I introduced in 1992 to Euro 6 introduced in 2014, and for heavy vehicles Euro 0 was introduced in 1988 and Euro IV in 2012. Specific details on the standards can be found on the European Commission website¹⁴².

In order to model emissions, the appropriate proportion of vehicles with different Euro engine standards for each fuel type should be given. This results in vehicle categories such as Euro 2 petrol or Euro 6 electric. These can be obtained for London and also for the Ultra Low Emissions Zone (ULEZ) which was introduced in April 2019 from a TfL sponsor.

4.2.2.3 Running the Model

Running an emissions model, once the inputs are set up, is usually as simple as providing links to any input files and hitting a Start or Calculate button. Depending on the emissions software used, the microsimulation data can be combined and averaged before, during or after the emissions modelling process. If multiple microsimulation seeds are processed separately they can be combined as part of the analysis or post processing.

142 <https://ec.europa.eu/environment/air/sources/road.htm>

4.2.3 Output Reporting

Reporting of emissions modelling should include details of the microsimulation model and how it is linked to the emissions model. The report should also state the assumptions made and the inputs used in the emissions model. Content will be software specific but should include:

- The objectives of the project including any aims for the emissions outputs;
- All the assumptions made along with their implications. For example, if no road gradient is used in an emissions model it assumes that all the roads are flat. This may be an issue in an area where there are a lot of roads with steep gradients;
- The sources of any supporting information. For example, if the proportion of the vehicle mix is based on the observed data or from any other study in the area, it needs to be clearly stated;
- Emissions estimations, produced for:
 - Each vehicle type; and
 - Each modelled link / section / segment;
- If possible, a geographical representation of the results. This should be produced for easy demonstration of changes (examples can be found in the relevant emissions software output sections);
- Analysis of the results. Any anomalies where results aren't as anticipated should be clearly highlighted and discussed; and
- A comparison of the results between different scenarios. Where multiple scenarios are being tested results should be compared, with the relative differences highlighted and explained.

The purpose of the modelling should be considered when reporting the results. Any proposals which cause a change in emissions will generally aim to move queuing traffic from a sensitive area, such as a high street or outside a school, to a location where emissions can disperse with less impact on other road users. In this case, localised changes in vehicle emissions can be more important than totals across the entire model.

As mentioned earlier, it may not be possible to collect observed data to configure all the parameters of the microsimulation and emissions models which influence the emissions output. Assuming the same data is used across all scenarios, any changes in emissions predictions should be the consequence of implementing the proposal in the microsimulation model,

so the results can be compared. By producing relative results rather than absolute values, any error in the estimation of the emissions should be consistent between scenarios. For this reason, it is advisable to report the results in terms of the change in emissions rather than the absolute values from each scenario.

4.3 EnViVer

EnViVer (Environmental Vissim-VERSIT+ simulations) is an emissions modelling software package specifically designed to calculate emissions based on the simulated traffic data from Vissim. It is developed by TNO (the Organisation for Applied Scientific Research) in the Netherlands. The vehicle emissions calculation in EnViVer is based on VERSIT+micro, which is a version of VERSIT+ that works on individual vehicle data with a one-second frequency. VERSIT+ is a collection of emissions models derived from measuring and analysing the emissions behaviours of more than 20,000 vehicles under different traffic situations. A screenshot of the EnViVer user interface is shown in **Figure 184**, and a full description of the functionality can be found in the EnViVer Manual¹⁴³.

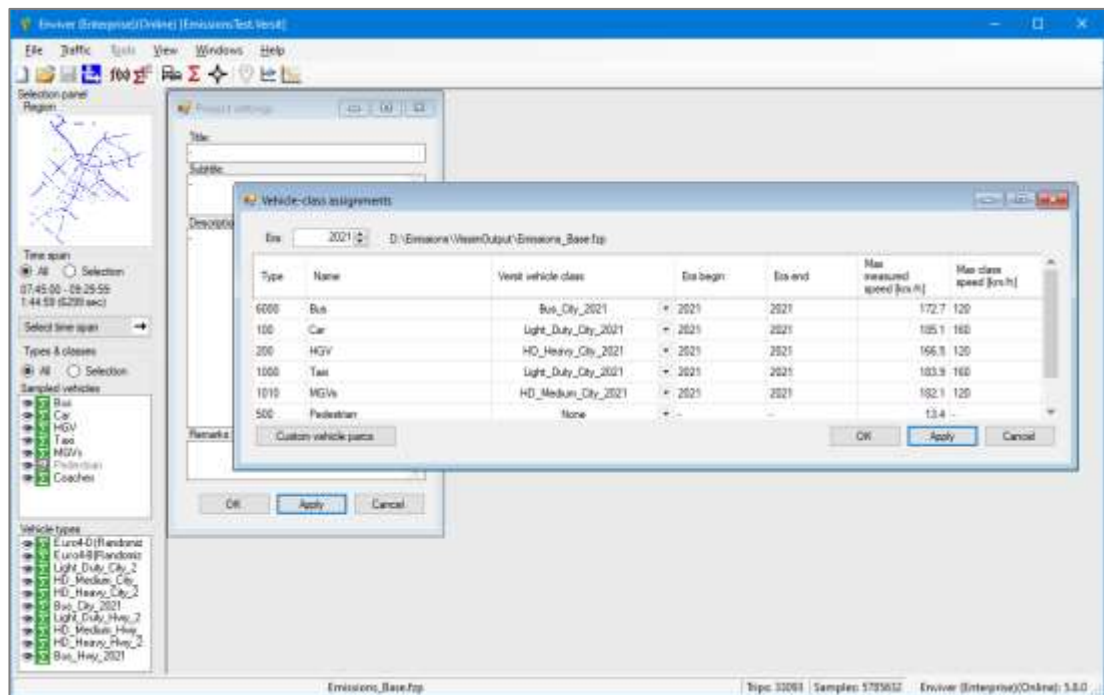

Figure 184: EnViVer main page

EnViVer allows users to define their own vehicle fleet models by configuring fuel type, vehicle age distribution and Euro engine standard proportions (section **C4.2.2.2**) so that the emissions calculations can be estimated based on local data. EnViVer also has batch processing and post-processing functionality which can be used to calculate, analyse and compare results for multiple different traffic scenarios.

143 Eijk A., Ligterink N and Inanc S. (2014). EnViVer Pro and Enterprise Manual, TNO (the Organization for Applied Scientific Research in Delft, the Netherlands)

4.3.1 Inputs

As outlined in section [C4.2](#), emissions modelling requires inputs on the emissions modelling side, relating to vehicle emissions characteristics, and on the microsimulation modelling side, relating to vehicle movements. This section details how these specifically relate to EnViVer.

4.3.1.1 Vehicle Record Data

EnViVer uses individual vehicle record data (known as *.fzp files in Vissim and Aimsun Next) which can be output from a microsimulation model. The vehicle record data should be collected at one second intervals for the required area and vehicle types. Vehicle record files are user configurable in Vissim (section [B7.7.2.7](#)) and should be set up to contain the following information at a minimum:

- Vehicle number: The unique number of each vehicle in the network;
- Vehicle type: The number of each vehicle type. At a minimum, this should include Car, HGV and Bus;
- Vehicle type name: The name of the vehicle type;
- Time: The simulation time as time of day [hh:mm:ss] (or simulation time in seconds);
- Speed: The speed of a vehicle at the end of the simulation second in kph;
- X-coordinate: The x-coordinate of a vehicle (vehicle front end at the end of the simulation step). This is not necessary for emissions modelling, but can be used for creating output plots;
- Y-coordinate: The y-coordinate of a vehicle (vehicle front end at the end of the simulation step). This is not necessary for emissions modelling, but can be used for creating output plots;
- Link: The unique number of each link / section / segment; and
- Gradient: The gradient of the link / section the vehicle is travelling on, if this is available.

In order for EnViVer to import the vehicle record file, the file and column headers need to be in one of two specific formats, relating to the formats output by older and more recent versions of Vissim (section [B7.1.2](#)). The older version is shown in [Figure 185](#), and is the easiest to replicate if manipulating outputs from software other than Vissim (the column spacing is not required). If using more recent versions of Vissim, it is important to note that the Vehicle Type column header needs to be VEHTYPE\NO and not simply VEHTYPE, or the import will not work. This can be achieved by selecting the vehicle type attribute from the expanding Vehicle Type list, rather than the main list, in a similar way to the Vehicle Type Name. Also, if required, the combined 'Coordinate front' attribute

should be selected, rather than the separate X and Y coordinates. Detailed requirements for the Vissim vehicle record data formatting can be found in the EnViVer manual¹⁴⁴.

```

Vehicle Record

File:      D:\Emissions\TestModel001.inp
Comment:   Emissions modelling
Date:      21 January 2021 11:50:28
VISSIM:    5.40-12 [44923]

VehNr      : Number of the Vehicle
Type       : Number of the Vehicle Type
VehTypeName : Name of the Vehicle Type
ToD        : Simulation Time as Time of Day [hh:mm:ss]
vMS        : Speed [m/s] at the end of the simulation step
WorldX     : World coordinate x (vehicle front end at the end of the simulation step)
WorldY     : World coordinate y (vehicle front end at the end of the simulation step)
Link       : Number of the Active Link
Grad       : Gradient [%] of the current link

VehNr; Type; VehTypeName; ToD; vMS; WorldX; WorldY; Link; Grad;
1; 100; Car; 07:15:01.0; 3.85; 537843.3344; 173977.2418; 30030; 0.00;
1; 100; Car; 07:15:02.0; 6.40; 537840.9230; 173972.8483; 30030; 0.00;
3; 100; Car; 07:15:02.0; 3.98; 537840.3201; 173977.4653; 30030; 0.00;
4; 100; Car; 07:15:02.0; 6.38; 537146.0004; 173317.2937; 30057; 0.00;
2; 100; Car; 07:15:02.0; 15.19; 536797.1596; 173280.9819; 30070; 0.00;
1; 100; Car; 07:15:03.0; 9.08; 537837.2978; 173966.0368; 30030; 0.00;
3; 100; Car; 07:15:03.0; 6.42; 537837.8212; 173972.9123; 30030; 0.00;
4; 100; Car; 07:15:03.0; 8.15; 537149.0653; 173323.8494; 30057; 0.00;

```

Figure 185: Format of the vehicle record data file (*.fzp) needed for EnViVer import

4.3.1.2 Vehicle Fleet Definition File

As a default, the four main categories which are used in VERSIT+micro are:

- Light duty vehicles (these include passenger cars and other vehicles with a mass ≤ 3500 kg);
- Buses (such as public transport buses, tour buses and coaches);
- Heavy duty medium (mass ≥ 3500 kg and 2 axles); and
- Heavy duty heavy (mass ≥ 20000 kg and 3 or more axles).

In addition, separate models have been created for urban areas, bus-only urban and a rural / highway combination. One of the main differences between them is that the vehicle fleet for an urban area contains a higher proportion of older cars and petrol cars compared to a rural / highway area.

¹⁴⁴ Eijk A., Ligterink N and Inanc S. (2014). EnViVer Pro and Enterprise Manual, TNO (the Organization for Applied Scientific Research in Delft, the Netherlands)

Vehicle parc

Light_Duty_City_2013
 HD_Medium_City_2013
 HD_Heavy_City_2013
 Bus_City_2013
 Light_Duty_Hwy_2013
 HD_Medium_Hwy_2013
 HD_Heavy_Hwy_2013
 Bus_Hwy_2013

Vehicle parc:
 Name: Light_Duty_City_2013
 Era: 2013
 Reset to road & vehicle type defaults

Road type:
 Urban Highway

Vehicle type:
 Light-duty Bus Heavy-duty

Fuel type

Fuel type	Percentage	Lock
Petrol:	67.0 %	<input type="checkbox"/>
Diesel:	30.5 %	<input type="checkbox"/>
LPG:	2.3 %	<input type="checkbox"/>
CNG:	0.1 %	<input type="checkbox"/>
Electric:	0.1 %	<input type="checkbox"/>

Vehicle age distribution

Newer than 1 year:	7.5 %
Average vehicle age:	7.7 year
Average exit age:	19.0 year
Maximum age:	40 year

Emission legislation

Euro norm	Regular date	Introduction date
Euro 1:	01/07/1992	1992 Year
Euro 2:	01/01/1996	1996 Year
Euro 3:	01/01/2000	2000 Year
Euro 4:	01/01/2005	2005 Year
Euro 5:	01/09/2009	2009 Year
Euro 6:	01/09/2014	2014 Year

Average regional CO2 emission

Petrol:	166 g/km
Diesel:	158 g/km

Figure 186: EnViVer custom vehicle distribution configuration window

To reflect local (city or country) vehicle characteristics, EnViVer facilitates the definition of a vehicle fleet using customisable properties (as shown in **Figure 186**):

- Fuel type proportion;
- Age distribution;
- Euro engine standard introduction date;
- Era; and
- Average CO₂ emissions for diesel / petrol vehicles.

For accurate emissions estimates, these proportions should be representative of modelled traffic and hence should be collected from the study area if possible. However, if this information is not available, the

composition should be based on TfL City Planning Directorate's vehicle composition data for London and/or ULEZ via a TfL sponsor.

EnViVer calculates the proportion of Euro engine standards of vehicles on the basis of vehicle age distribution and emissions legislation. The age distribution, combined with the specified era, results in a Euro-class distribution which should be cross-checked against the actual proportion from observed data, if available. Further information can be found in the EnViVer manual¹⁴⁵.

4.3.1.3 Assigning EnViVer Emissions Classes

Once vehicle record data from a microsimulation model has been imported into EnViVer, the vehicle types defined in the microsimulation model must be linked to vehicle emissions classes. EnViVer automatically shows the Vehicle-class assignments screen (**Figure 187**) after importing a new vehicle records file. The availability of the emissions classes depends on the selected era. All simulated vehicles with the emissions class set to 'None' are excluded from the emissions calculations, therefore appropriate values for matching vehicle types should be entered before starting the emissions calculations.

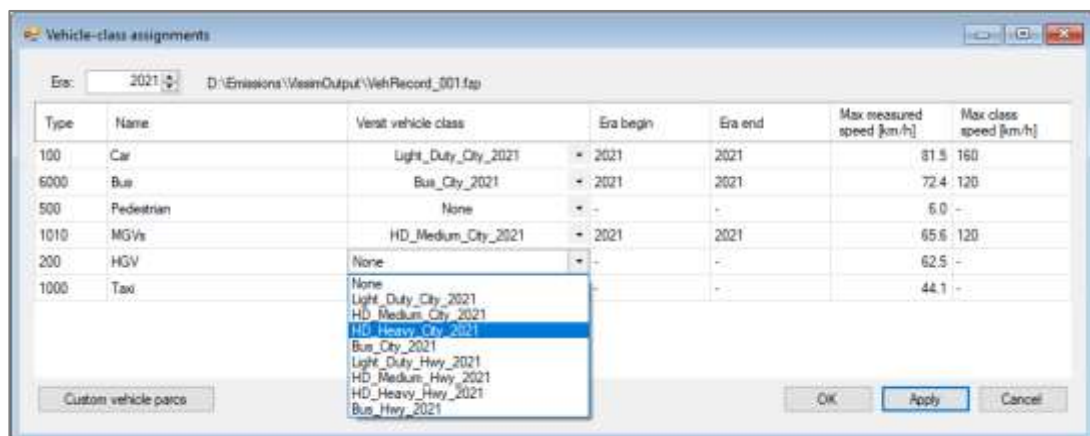

Figure 187: Vehicle-class assignments window screenshot

Emissions calculations in EnViVer are based on either pre-defined or user-defined vehicle emissions classes. The pre-defined vehicle emissions classes are based on the average Dutch fleet composition and are fixed, meaning that the user cannot change the contents of the underlying emissions model. If the data is available, the user should create a custom vehicle fleet that is more suitable to their specific situation by using user-defined vehicle emissions classes in EnViVer (section **C4.3.1.2**). Whichever

145 Eijk A., Ligterink N and Inanc S. (2014). EnViVer Pro and Enterprise Manual, TNO (the Organization for Applied Scientific Research in Delft, the Netherlands)

emissions classes are used, they must be the same across all modelled scenarios to give a fair comparison.

4.3.1.4 Data Verification

The analysis performed by EnViVer is reliant on realistic speed-time profiles being generated for each vehicle that is included. As indicated in the EnViVer manual¹⁴⁶:

“accelerations over 3m/s^2 are quite severe, especially at higher speeds ($V > 50\text{kph}$). The maximum acceleration should not exceed 4 to 5m/s^2 . Decelerations are in general maximum -3 to -4m/s^2 . The decelerations sometimes exceed these values but can never exceed approximately 10m/s^2 .”

EnViVer provides tools to examine the data in the vehicle record file.

The Speed-Acceleration plot provides a visual representation of the relative frequencies of speed-acceleration combinations over all vehicles in the vehicle record file. Blue shows occurrences, with higher frequencies moving towards red. **Figure 188** shows a reasonable range of values as the bulk of the points at all speeds are between $+3\text{m/s}^2$ and -3m/s^2 , with a few larger decelerations.

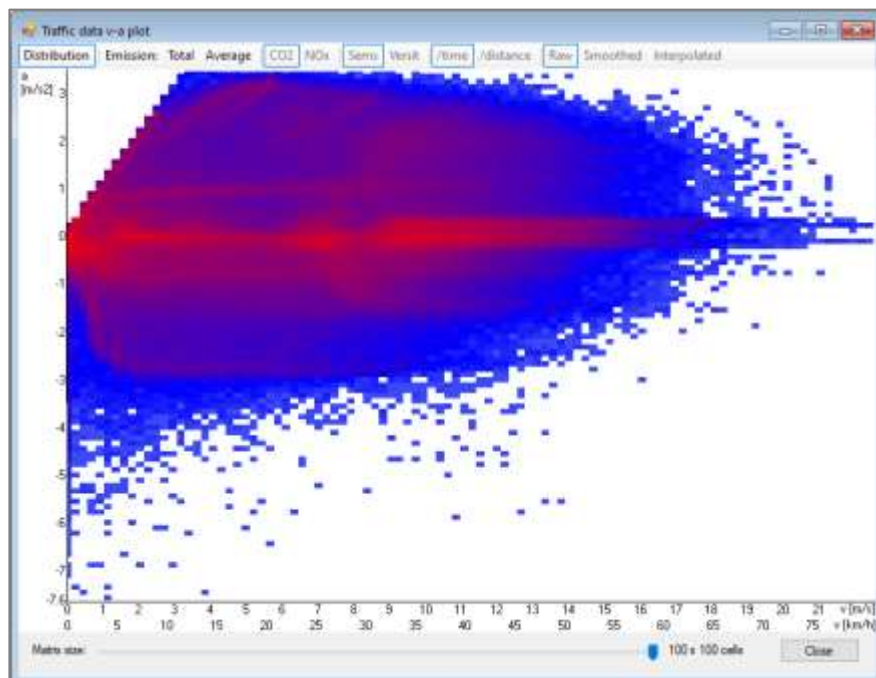

Figure 188: EnViVer Speed-Acceleration plot

146 Eijk A., Ligterink N and Inanc S. (2014). EnViVer Pro and Enterprise Manual, TNO (the Organization for Applied Scientific Research in Delft, the Netherlands)

As already mentioned, the basis of EnViVer emissions calculations is the speed-time curves produced by each vehicle. It is possible to view these profiles for individual vehicles via the Samples per trip plot (Figure 189). This has a list of all the vehicles on the left, together with a status column which highlights any vehicles that have anomalous speed or acceleration values. If too many of these errors are highlighted then the cause should be investigated before carrying out emissions calculations.

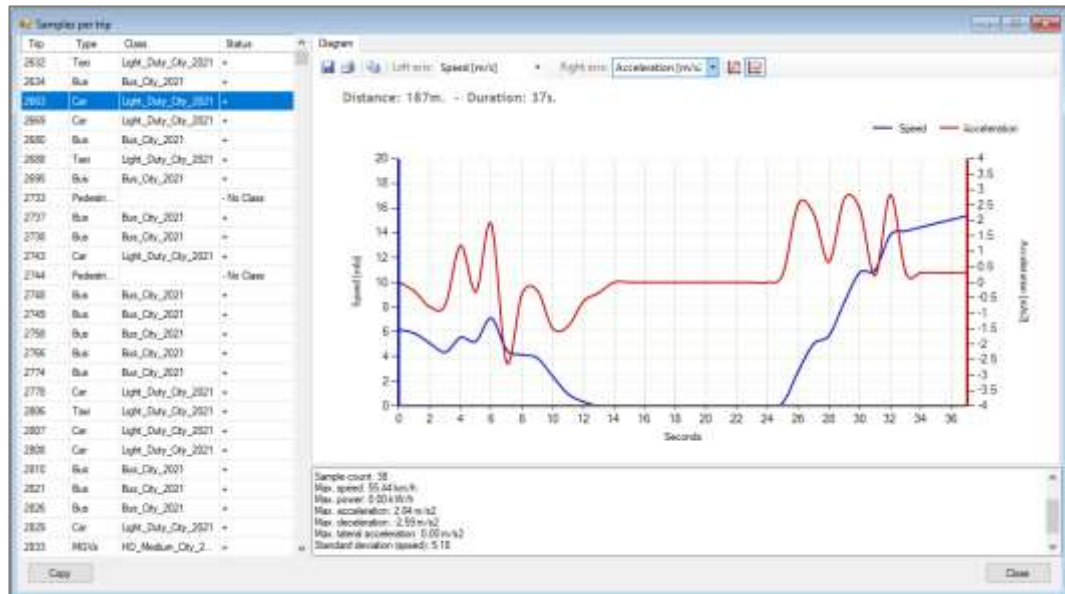

Figure 189: EnViVer speed and acceleration plot for an individual vehicle

4.3.2 Outputs

Based on the analysis of the EnViVer output, a report should be produced as described in section C4.2.3. EnViVer provides tools to produce the content for this report.

4.3.2.1 Report

EnViVer produces a concise report file (*.emissions) giving total emissions for the study area and for each vehicle emissions class. For more detailed analysis, EnViVer allows the selection of specific areas of the network, time intervals or vehicle emissions classes.

4.3.2.2 Plots

EnViVer has facility to plot vehicle emissions in the study area (Figure 190). Such plots are useful for visual identification of the impacts of any proposals, for example, hot spots of vehicle emissions or congested areas.

The plots can be set up with a grid size of 5m, 10m or 25m. The options available are traffic flow data (count per grid cell, average speed, sum of distance travelled), total emissions (per grid cell) and emissions per kilometre.

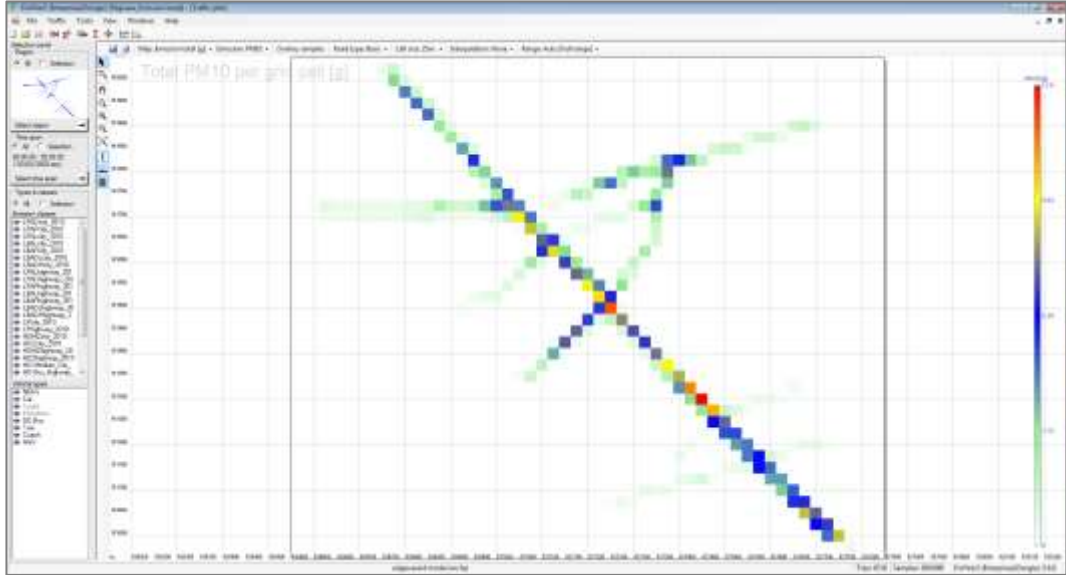

Figure 190: A screenshot showing EnViVer plot of PM₁₀ emissions

EnViVer can also output text files for use in external software, using the Save map data to Raster GIS file button in the plot window (Enterprise version of EnViVer only). Figure 191 shows an EnViVer output file (*.asc) with the values plotted and coloured in a spreadsheet.

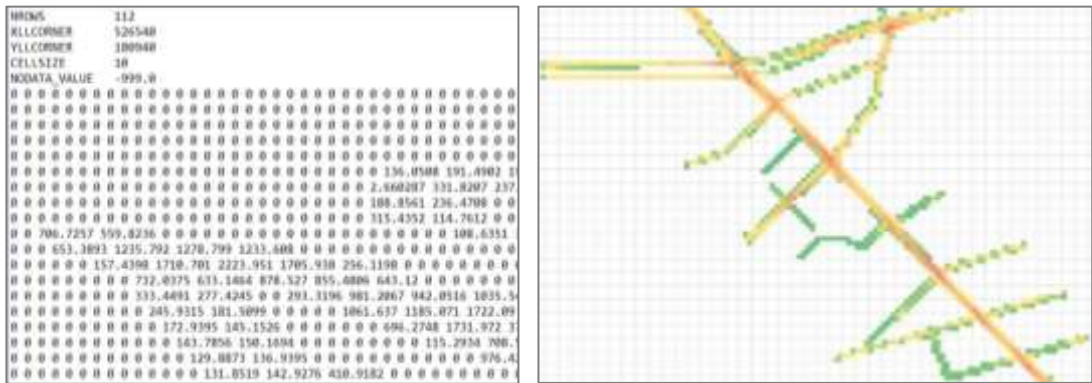

Figure 191: Excerpt from an EnViVer output file (*.asc) file and Excel plot of the output file values

4.3.2.3 Post Processing

The post processing tool in the Enterprise version of EnViVer provides functionality to:

- Calculate an average of the results of different traffic simulation runs; and
- Compare the results from different scenarios.

The tool can calculate and output results from any scenarios which have been run previously and stored using File > Export binary report. Post processing results can be viewed using the VERSIT Report Viewer, which must be installed separately to EnViVer. The resulting plots are similar in appearance to those shown above.

4.4 PHEM

PHEM (Passenger car and Heavy duty Emission Model) is an emissions modelling software package developed by Technical University of Graz (TUG) for calculating vehicle emissions. PHEM calculates the emissions of vehicles on the basis of their speed and acceleration / deceleration rates.

The model calculates the engine power output and engine speed from vehicle positions, speeds and accelerations, so any driving condition can be modelled as long as the vehicle record files are available. The simulation of different vehicle payloads in combination with road gradients, variable speeds and accelerations can be modelled replicating the different gear-shifting behaviour of drivers.

There are three versions of PHEM: STANDARD, BATCH and ADVANCE. PHEM STANDARD only requires the entry of speed curves (a vehicle's speed every second), whereas PHEM ADVANCE has the facility to configure individual vehicles if required. PHEM BATCH is a version of PHEM STANDARD with additional batch processing capability. ADVANCE mode, which allows calculations using the output of a traffic microsimulation model, should be used for the modelling work discussed here. The version of PHEM which will be used is selected on the Options tab, as shown in **Figure 192**.

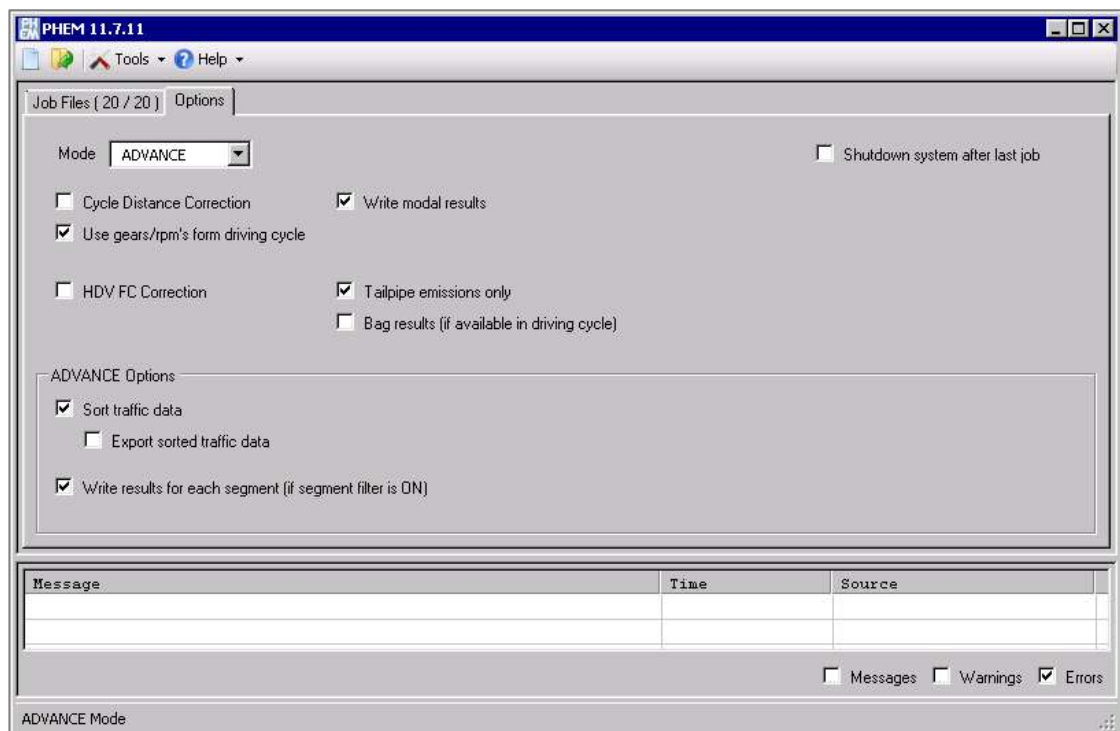

Figure 192: Options tab in the PHEM user interface

PHEM includes an extensive database of previously measured vehicles and engines for the calculation of road traffic emissions, however emissions levels can also be modelled for other types if the vehicle specifications are provided. The data is compiled as average vehicles, which illustrate the vehicle categories of passenger, light duty and heavy duty vehicles with petrol and diesel engines from Euro 0 to Euro 6 standards. The database for the average vehicles in PHEM comes from several national and international research projects.

PHEM uses the vehicle type as given in the vehicle record file and assigns the fuel type and Euro engine standard (such as Euro 5 petrol) to every individual vehicle according to the proportions given in the vehicle fleet composition file. It then calculates the emissions output for a vehicle depending on its speed at every second.

4.4.1 Inputs

PHEM uses various files (examples include vehicle specification, engine map, load and drag curve) to calculate emissions for all the vehicle categories given in the vehicle record data. It provides default files for a selection of vehicle categories based on measurements from different laboratories (TUG, EMPA – Swiss Federal Laboratories for Materials Science and Technology, and TNO). These vehicle categories differ in terms of their types, fuel types and EU engine standards. However, as driving conditions and driving behaviours differ between countries and cities, the latest files available from a TfL sponsor should be used if possible. These files will be the same in every study, unless they are updated or the study has vehicle categories which are not covered. The source of these files should be clearly identified in the report, as mentioned in section [C4.2.3](#).

Besides the input data for the definition of vehicle categories, other input files that are specific to a simulation study are needed. These input files are described below.

4.4.1.1 Job File

To run PHEM, a job file (*.adv), storing information for a simulation, is needed. This includes:

- Path of the vehicle record file (*.fzp);
- Path of the fleet composition file (*.flt);
- Paths of segment data files; and
- Job Settings (defining the type of the output needed).

If all required input files are available, PHEM starts the calculation and writes the output files into the path where the job file is stored. The output files have the same file name as the job file (*.adv) with different extensions (section C4.4.2). Job files can be created by using the ADV editor within PHEM, as shown in Figure 193, or by writing directly using a text editor.

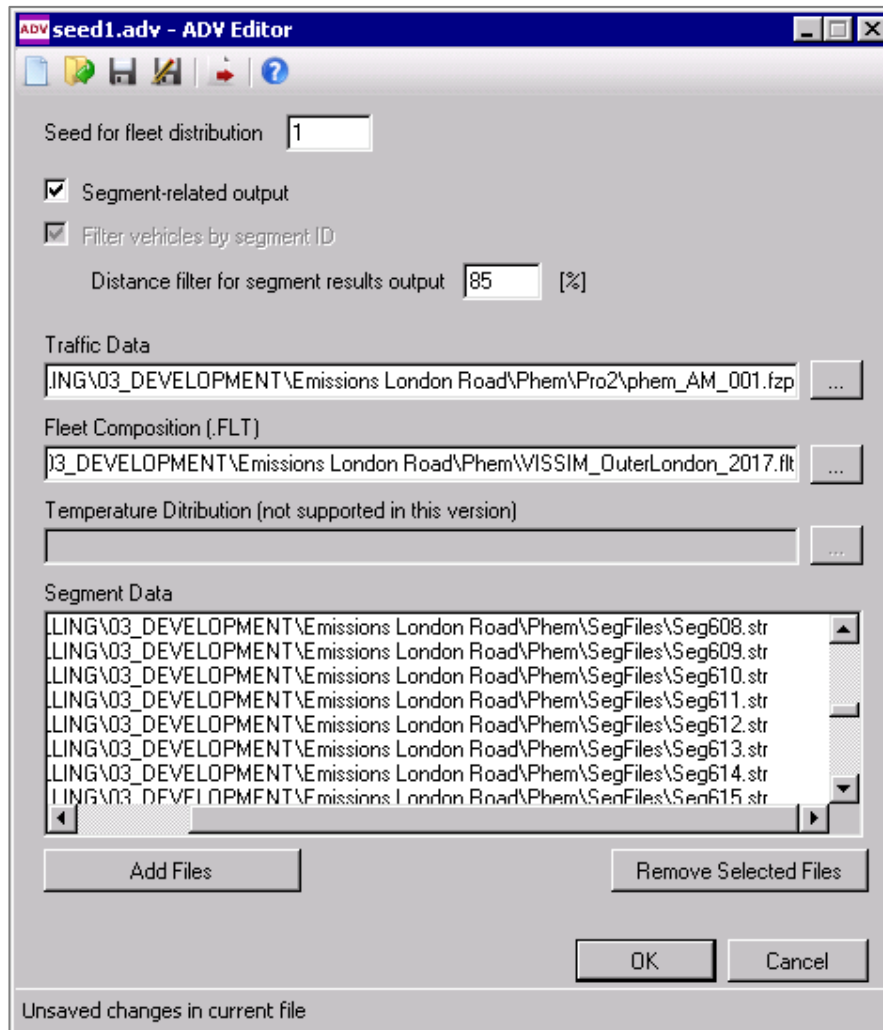

Figure 193: ADV editor which can be used to generate job files (*.adv)

The job files to be run are selected in the Job Files tab of the user interface, as shown in Figure 194. Each microsimulation run requires a separate job file.

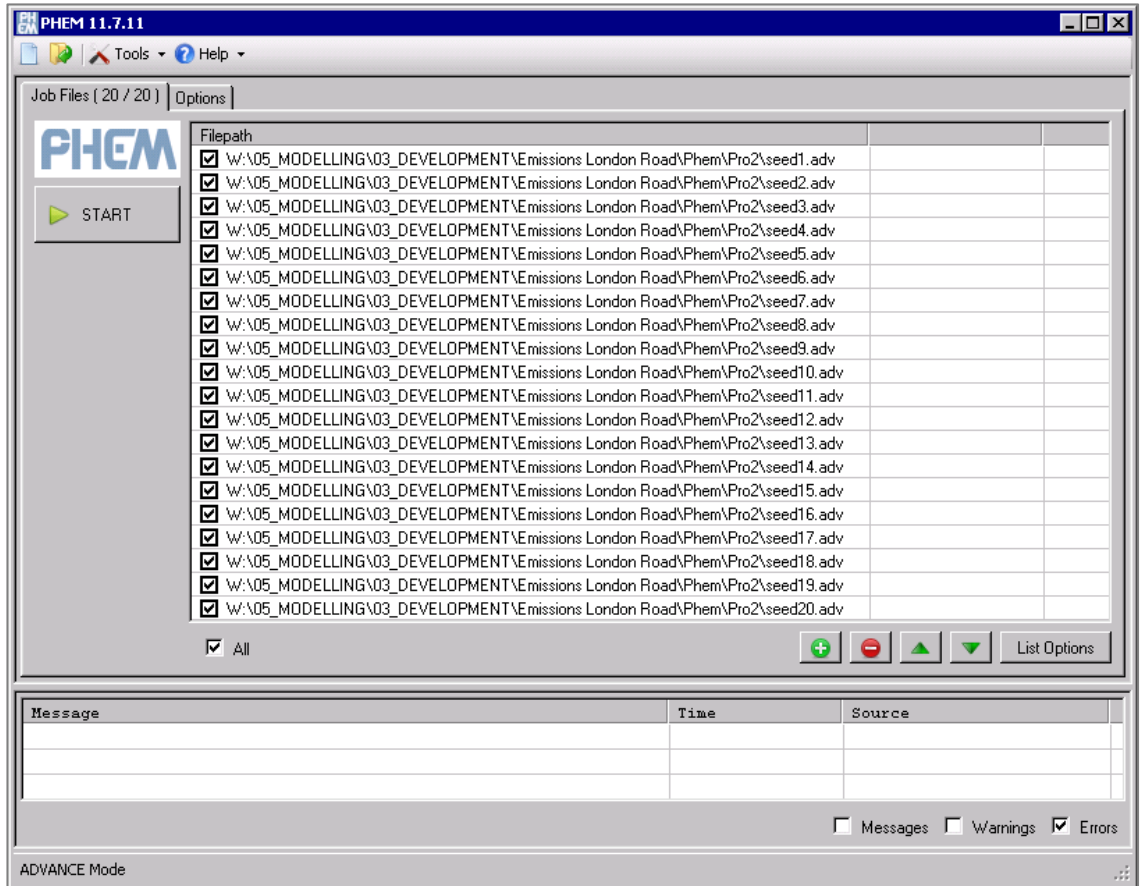

Figure 194: Screenshot of the Job Files tab in the PHEM user interface

4.4.1.2 Vehicle Record Data

PHEM has a pre-specified data structure for vehicle record data which needs to be collected with a one-second time interval from a microsimulation model. The data should be processed (if not already in the required structure) to include information as given below. The vehicle record data for PHEM should be in text format with data separated by semicolon, as shown in **Figure 195**:

- **Time** – A time in seconds. Needs to be an integer value in a sequence for each vehicle in the simulation (numbered after sorting the data by vehicle ID);
- **X-coordinate** – The x-coordinate of a vehicle at a simulation second;
- **Y-coordinate** – The y-coordinate of a vehicle at a simulation second;
- **Vehicle number** – The unique number of each vehicle in the network;
- **Speed** – The speed of a vehicle at a simulation time in kph (a conversion may be necessary if the output from a simulation model is in m/s);
- **Gradient** – The average gradient of a road link / section expressed as a percentage (section **C4.2.1.4**);
- **Vehicle type** – The type number of each vehicle category (for example Car, HGV, Bus and so on). The vehicle type numbers of all vehicle categories are predefined in PHEM and should be adopted in the vehicle record data accordingly (data processing is needed if the data from a simulation model is not same). The vehicle type numbers used in PHEM are:
 - 100=passenger vehicle
 - 200=freight vehicle
 - 300=light duty vehicle
 - 400=articulated vehicle
 - 500=city bus
 - 600=coach
 - 700=two-wheeler; and
- **Segment ID** – The unique number of each link / section / segment. Links / sections can be grouped into segments before the PHEM calculation or during the analysis of the output.

```

time;x;y;vehid;speed;gradient;vehdtype;section
0;531926.312;179129.892;235;34.4559694;0;900;208
1;531933.692;179123.818;235;35.1318922;0;900;208
2;531943.882;179123.486;235;35.807815;0;900;208
0;531898.375;179167.217;250;2.6232242;0;900;262
1;531899.269;179166.162;250;7.3385904;0;900;262
2;531901.011;179164.108;250;12.0539566;0;900;4
3;531903.552;179161.062;250;16.7693228;0;900;4
4;531907.042;179157.055;250;21.484689;0;900;4
5;531911.537;179152.23;250;25.8942806;0;900;613
6;531915.627;179146.022;250;27.2300328;0;900;613
7;531919.969;179139.671;250;28.1473566;0;900;613
8;531924.451;179133.108;250;29.0646804;0;900;10607
9;531929.094;179126.561;250;28.8232794;0;900;208
10;531936.318;179123.172;250;27.8898622;0;900;208
11;531944.248;179123.569;250;26.9725384;0;900;208
0;531699.496;179387.985;259;25.8460004;0;900;264
1;531694.92;179393.441;259;25.186171;0;900;264
2;531690.495;179398.683;259;24.2044736;0;900;264
3;531686.23;179403.697;259;23.2066828;0;900;264
4;531682.107;179408.471;259;22.208892;0;900;264
5;531678.103;179413.06;259;22.0801448;0;900;10137
6;531673.543;179417.363;259;23.0618422;0;900;130
7;531669.04;179422.114;259;24.059633;0;900;130
8;531663.718;179426.363;259;25.0574238;0;900;130
0;531859.121;179206.251;263;19.6500414;0;900;167
1;531862.092;179201.778;263;18.0085146;0;900;167
2;531864.548;179197.74;263;16.6083888;0;900;167
3;531867.378;179193.289;263;20.8731398;0;900;10001

```

Figure 195: An example vehicle record data file (*.fzp) extract

4.4.1.3 Vehicle Fleet Composition File

The fleet composition file (*.flt) is an input file which contains the proportions of different vehicle categories. PHEM assigns the fuel type and Euro engine standard (such as Euro 5 petrol) to every individual vehicle according to the proportions given in the fleet composition file. For accurate emissions estimates, these proportions should be representative of the modelled traffic. Therefore, as far as possible, this information should be collected from on-street observed data. An example of a fleet composition file is shown in [Figure 196](#).

```
c column 1: Vehicle Type ID ...used to assign vehicles in the .fzp file (column 7),,,,,,
c column 2: gen file ...name of the PHEM .gen inpute file. Use <VEHDR> for Default Vehicles.,,,,,,
c column 3: percentage ... share percentage of vehicle category. Category sum = 100% (NOT total fleet sum!),,,,,,
c column 4+: optional information,,,,,
c Vehicle Type ID,gen file,percentage,type,Fuel Type,EURO Class,Size Class,AGR/SCR (HGV)
c VISSIM vehicle categories = 100 PC + LGV (need to fuse) | 200 HGV artic |
c
c PASSENGER CAR: petrol, diesel, hybrid (petrol - rough), EV
100,<VEHDR>\PC\PC_EU0_G.GEN,0,PC,Gasoline,0,Average,-
c includes those with Failed CAT
100,<VEHDR>\PC\PC_EU0_G.GEN,0.00944,PC,Gasoline,0,Average,-
100,<VEHDR>\PC\PC_EU1_G.GEN,0.00311,PC,Gasoline,1,Average,-
100,<VEHDR>\PC\PC_EU2_G.GEN,0.01918,PC,Gasoline,2,Average,-
100,<VEHDR>\PC\PC_EU3_G.GEN,0.08740,PC,Gasoline,3,Average,-
100,<VEHDR>\PC\PC_EU4_G.GEN,0.12002,PC,Gasoline,4,Average,-
100,<VEHDR>\PC\PC_EU5_G.GEN,0.09615,PC,Gasoline,5,Average,-
100,<VEHDR>\PC\PC_EU6_G.GEN,0.09123,PC,Gasoline,6,Average,-
100,<VEHDR>\PC\PC_EU0_HybridG.GEN,0.00018,PC,HybridGasoline,0,Average,-
100,<VEHDR>\PC\PC_EU3_HybridG.GEN,0.00008,PC,HybridGasoline,3,Average,-
100,<VEHDR>\PC\PC_EU4_HybridG.GEN,0.00153,PC,HybridGasoline,4,Average,-
100,<VEHDR>\PC\PC_EU5_HybridG.GEN,0.00471,PC,HybridGasoline,5,Average,-
100,<VEHDR>\PC\PC_EU6_HybridG.GEN,0.01056,PC,HybridGasoline,6,Average,-
100,<VEHDR>\PC\PC_EV.GEN,0.00138,PC,EV,EV,Average,-
```

Figure 196: An example fleet composition file (*.flt) extract

4.4.1.4 Segment Data File

PHEM writes output files for each segment data file (*.str) defined, which can be used to analyse the results on an individual segment basis. These defined segments need to be included in the vehicle record file (*.fzp) and also specified in the input definition file (*.adv). An example of a typical segment file is shown in [Figure 197](#).

```
Str: Segment ID
Sp: Lane nr
SegAnX: Segment start x
SegEnX: Segment end x
SegAnY: Segment start y
SegEnY: Segment end y

Str; Sp; SegAnX; SegEnX; SegAnY; SegEnY;
130;0;0;0;0;0
```

Figure 197: An example segment data file (*.str)

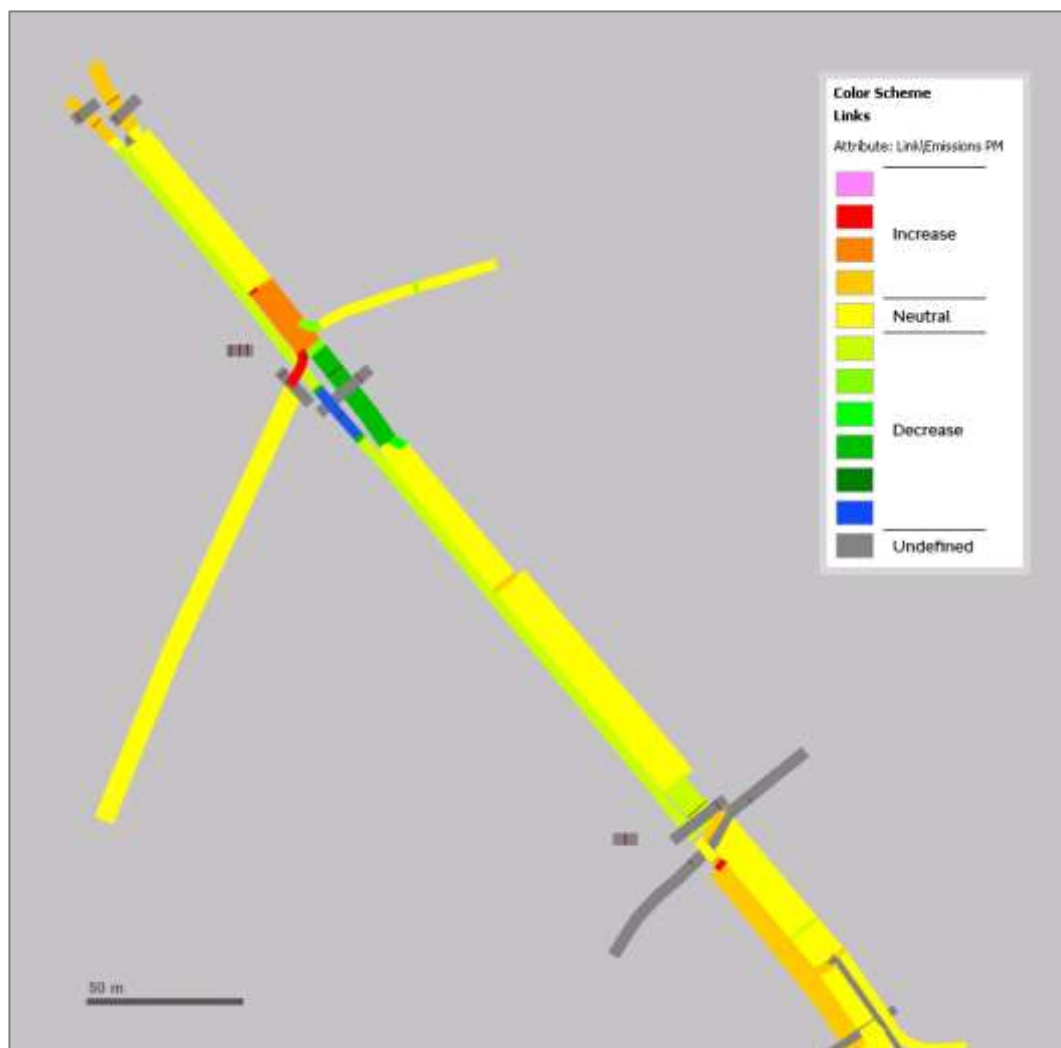

Figure 201: Difference in NO_x levels between two scenarios

Closing Summary

These Traffic Modelling Guidelines, produced by the Network Management Directorate within TfL Surface Transport, provide overarching guidance on the appropriate standards of traffic modelling required when proposing a traffic signal scheme within London.

Modelling experts within TfL and across the industry have contributed to this document. The document can be read as a whole, but can also be used as a reference for particular traffic modelling issues. **Part A** provides a high-level overview of traffic modelling for a non-technical audience, whilst **Part B** presents specific advice and standards for practitioners. **Part C** introduces techniques for modelling active travel modes in support of the Healthy Streets philosophy within the Mayor's Transport Strategy.

The content of these Guidelines is correct at the time of publishing, based on software versions currently in use within TfL. Since traffic modelling software developers frequently release new versions, this document is considered a source of evolving guidance. It continues to be updated with advice on best practice covering new products, concepts and techniques as they are developed and tested in our working environment.

All advice provided in the Traffic Modelling Guidelines is non-binding but is directly related to the way TfL operates London's traffic management systems. This document builds upon the success of the three previous versions, which have been used as guidance during the development of numerous traffic models both in the UK and overseas.

The latest version of this document is available to download from:
<https://tfl.gov.uk/trafficmodelling>

We encourage feedback on the advice given in this document. Please address all comments, specifying that they are related to the Traffic Modelling Guidelines Version 4.0, to:

TfL Traffic Modelling Guidelines
Modelling & Visualisation
Network Management Directorate, Surface Transport
Transport for London
3rd Floor, Palestra
197 Blackfriars Road
LONDON
SE1 8NJ

TfLModellingGuidelines@tfl.gov.uk

Contacts

The list below provides a summary of all the email addresses that have been identified in the Traffic Modelling Guidelines and a description of their use.

AssetOperationsDataLegalRequest@tfl.gov.uk - Traffic signal information, including site reference numbers, site paperwork and demand-dependent stage frequency data (section **B2.2.1**).

Cynemon@tfl.gov.uk - Information on the Cynemon strategic cycling model (section **C2.2.3**).

ModellingData@tfl.gov.uk – Requests to access modelling data (sections **B2.3.1** and **C2.3.1**).

NMSchemeAssessment@tfl.gov.uk – Model audit submissions to Network Performance (section **B2.1.5**).

ONE@tfl.gov.uk – Information on TfL's Tactical Highway Assignment model (the ONE Model, section **B5.2.2**).

PPD3rdPartyRequests@tfl.gov.uk – Registration of schemes on to the NM Workbook (section **A3.6.1**).

StrategicModelling@tfl.gov.uk – Information on TfL's Strategic Highway Assignment suite (including MoTiON, LoHAM, Railplan and Cynemon), including accreditation for use of the ONE Model (section **B5.2.1**).

StreetsPedestrianModelling@tfl.gov.uk – Information and guidance on pedestrian modelling within Network Management (section **C3.3.1**).

TfLModellingGuidelines@tfl.gov.uk – Feedback on the contents of the Traffic Modelling Guidelines and discussion of evolving modelling techniques (section **A6**).

Glossary

Term	Description
ACC	Automated Cycle Counters – provide volume and speed data for cyclists (section B2.3.1)
Aimsun	Developer of Aimsun Next, formerly TSS (Chapter B3)
Aimsun Next	Advanced Interactive Microscopic Simulator for Urban and non-urban Networks – modelling software developed by Aimsun (Chapter B3)
AMAP	Aimsun (Next) Model Auditing Process (see MAP) (sections A3.6.1 and B2.1.5)
ANPR	Automatic Number Plate Recognition – a method of counting and classifying vehicles using their number plates (section B2.3.4.1)
ARCADY	Assessment of Roundabout Capacity And DelaY – modelling software developed by TRL (section A5.1.2)
ASL	Advanced Stop Line – area in front of the main traffic stopline so cyclists can wait in front of other vehicles (section A4.5.5 and Chapter C2)
ATC	Automated Traffic Counters – roadside infrastructure which measures the volume and speed of traffic (section B2.3.1)
CAD	Computer-Aided Design – using computer software to record or design something, in modelling it usually refers to vector drawings of the layout of a particular junction (section C3)
CE	Checking Engineer – key role identified in MAP (sections A3.6.1 and B2.1.5)
CFP	Cyclic Flow Profile – a feature of deterministic modelling that displays a graph of the arrival pattern of vehicles at a stopline (sections B4.7.2 and B6.7.2.2)
CLF	Cableless Linking Facility – method by which signal controller timings are linked together using an internal clock (section B2.3.8.4)
CPDM	Congested Platoon Dispersion Model – a traffic model used in TRANSYT that accounts for flare blocking (section B6.4.3.3)
CTM	Cell Transmission Model – a traffic model used in TRANSYT that accounts for exit-blocking (section B6.4.3.4)

CYOP	CYcle time OPtimisation – a TRANSYT feature used to select an appropriate cycle time for a modelled network (section B6.6.4.1.4)
DE	Design Engineer – key role identified in MAP (sections A3.6.1 and B2.1.5)
DfT	The Department for Transport (section A2.1.2)
DMRB	Design Manual for Roads and Bridges – document containing information about the current standards on motorways and trunk roads in the United Kingdom (section A4.5.2.1)
DoS	Degree of saturation – measure used to determine how busy a stopline is by looking at the percentage of the capacity that is used (section B2.3.10)
DSD	Desired Speed Decision – used in Vissim modelling to set speed limits (section B7.4.2.3)
EIA	Environmental Impact Assessment – report on a scheme that should consider estimated emissions, traffic, noise and vibration, visual impact and impact on local ecology (section A4.5.6)
EQUISAT	A TRANSYT feature that provides an initial set of signal timings prior to optimisation, based on equal saturation of critical conflicting links (section B6.6.4.1.1)
FT	Fixed time – Traffic signal control method under UTC (see UTC) which operates via set plans which change by time of day (section B2.3.8.2)
FlowRound	Software for the analysis of spiral traffic lane movements at signalised and unsignalised roundabouts, developed by JCT (section B6.4.7.1)
Fusion	An optimisation algorithm, which is part of the RTO, and will replace SCOOT (section B2.3.8.2)
GIS	Geographic Information System – computer program that works with spatial data and mapping
GLA	Greater London Authority – administrative body responsible for the strategic administration of Greater London
GPS	Global Positioning System – a satellite-based navigation system that provides location and time information (section B2.3.4.3)
HCM	Highway Capacity Manual – publication of the Transport Research Board in the USA, containing guidelines and procedures

for computing the capacity and quality of service of various types of highway facilities (section [B3.7.1](#))

HGV	Heavy Goods Vehicle – vehicle classification including all goods vehicles with three or more axles (section B2.3.4.1.1)
HTA	Highway Traffic Assignment – a distribution of the travel on a set of routes among Origin-Destination pairs that estimates flows in such a way that no one vehicle can find a better generalised travel cost by switching its route (Chapter B5)
ICA	Intersection Capacity Analysis – used in Visum modelling to estimate the capacity of intersections (section B5.1)
IDP	Investment Delivery Planning, formerly Sponsorship, are the team that advocates TfL schemes.
ITN	Integrated Transport Network – a former layer from Ordnance Survey’s MasterMap, now replaced by the Highways Network layer (section B2.3.6.2)
JCT	JCT Consultancy Ltd – developer of FlowRound, LinSat, LinSig and TranEd (Chapter B4)
LMAP	LinSig Model Auditing Process (see MAP) (sections A3.6.1 and B2.1.5)
LEGION	Pedestrian modelling software, developed by Bentley (section C3.3.2.1)
LGV	Light Goods Vehicle – vehicle classification including all goods vehicles up to 3,500kg gross vehicle weight (section B2.3.4.1.1)
LinSat	Freely available software developed by JCT, allowing the estimation of effective flare usage based on flow data (section B2.5.2.2)
LinSig	Deterministic modelling software developed by JCT (Chapter B4)
LTA	Local Traffic Authority – the body responsible for local roads (section A2.1)
MAE	Model Auditing Engineer – key role identified in MAP (sections A3.6.1 and B2.1.5)
MCC	Manual Classified Counts – provide traffic turning count data (section B2.3.1)
MAP	Model Auditing Process – TfL’s framework which leads all interested parties through model development, submission and auditing (sections A3.6.1 and B2.1.5)

MGV	Medium Goods Vehicle – vehicle classification including all goods vehicles with 2 axles over 3,500kg gross vehicle weight
MME	Mean Modulus of Error – in TRANSYT modelling, a numerical value between zero and two, indicating how bunched a travelling platoon remains as it progresses between junctions (section B6.7.2.2)
MMQ	Mean Maximum Queue – the average of the maximum queue lengths in each cycle, used in deterministic modelling (sections B4.6.4.1.2 and B6.6.4.1.7)
MoTiON	Model of Travel in London – TfL’s strategic demand model, replacing London Transport Study, which covers all of Greater London and is built and used by TfL’s City Planning Demand Forecasting and Analytics team. (section A3.4.4)
MOVA	Microprocessor Optimised Vehicle Actuation – an improved method of VA which is more responsive to traffic conditions (section B2.3.8.4)
MTS	Mayor’s Transport Strategy – a document published by the Mayor of London, which sets out the Mayor’s policies and proposals to reshape transport in London over the next two decades (section A2.1)
NAE	Network Assurance Engineer – key role identified in MAP (sections A3.6.1 and B2.1.5)
NIST	Network Impact Specialist Team – team within TfL that works on behalf of the Traffic Manager to ensure that the NMD has been fully complied with in the development, design and implementation of highway scheme proposals impacting on London’s major roads (section A2.1.2)
NMD	Network Management Duty – under the TMA, requires an authority to manage all their activities in such a way as to maximise the efficiency of movement on their road network and minimise unnecessary delay (section A2.1)
NP	Network Performance (within NM), formerly Urban Traffic Control (UTC) (About the Authors)
OD	Origin-Destination – a matrix used to input traffic flows into a model, with the origins as rows and the destinations as columns
ONE	Operational Network Evaluator – TfL’s tactical model which covers Greater London and is used to assess schemes and investigate the implications of local network changes on the wider network (section B5.2.2)

OS	Ordnance Survey – the national mapping agency for Great Britain (section C3.4.3)
P	Promoter – key role identified in MAP (sections A3.6.1 and B2.1.5)
PCU	Passenger Car Unit – a common unit used to represent general traffic where vehicle types are assigned a conversion factor to the equivalent number of cars based on the amount of road space they take up (section B2.3.4.1.1)
PDM	Platoon Dispersion Model – the traditional traffic model used in TRANSYT (section B6.4.3.1)
PHEM	Passenger car and Heavy duty Emission Model – an emissions modelling software package developed by Technical University of Graz for calculating vehicle emissions on the basis of their speed and acceleration / deceleration rates (section C4.4)
PI	Performance Index – a monetary value used in TRANSYT to assess the cost of stops and delays in a network (section B6.1.3)
PICADY	Priority Intersection Capacity And DelaY – modelling software developed by TRL (section A5.1.2)
PRC	Practical Reserve Capacity – the spare capacity of a junction, used by LinSig during optimisation (section B4.6.4.1)
Prior matrix	The result of the matrix building process, including the use of observed data, data cleaning and infilling methods (such as a with a gravity model). This stage of development occurs before the final matrix adjustments during calibration and validation.
PTV	Planung Transport Verkehr (PTV) AG – developer of Vissim and Visum (Chapter B7 and section A5.3.3)
QueProb	TRANSYT feature allowing the estimation of effective flare usage based on flow data (section B6.4.4.4)
RFC	Ratio of Flow to Capacity – measure used to determine how busy an approach is at an unsignalised junction (section B2.3.4.4)
RR67	Research Report 67 – publication by TRL describing a methodology for the prediction of saturation flows (section B2.3.9.1)
RSA	Reduced Speed Area – used in Vissim modelling to implement changes in speed due to road geometry or factors that cannot be directly modelled (section B7.4.2.3)

RTO	Real Time Optimiser – the traffic signal control system that will replace TfL’s Urban Traffic Control (UTC) system (section B2.3.8.2)
SAE	Signals Auditing Engineer – key role identified in MAP (sections A3.6.1 and B2.1.5)
SASS	System Activated Strategy Selection – an automated method of adjusting on-street signal timings based on particular traffic flow criteria (section B2.3.8.2)
SATURN	Simulation and Assignment of Traffic to Urban Road Networks – modelling software suite developed by the Institute for Transport Studies, University of Leeds, and distributed by Atkins Ltd. (section A5.3.2)
SCOOT	Split, Cycle and Offset Optimisation Technique – technology that controls and optimises signal timings across London, developed by TRL (section B2.3.8.2)
SIR	Scheme Impact Report (formerly TSSR, Traffic Signal Supplementary Report) – a report on the impact of schemes which enables NIST to ensure that TfL is meeting the NMD (section A4.6.1)
SITS	Surface Intelligent Transport Systems – the programme within TfL that aims to respond to the future challenges that face London’s road network (section B2.3.8.2)
SLD	Site Layout Drawing – diagram showing the layout of junctions including the locations of all street furniture and ducting (section B2.3.1)
SQA-0640	TfL series of documents containing Design Standards for Signal Schemes in London (formerly SQA-0064) (section A4.5.2.1)
SRN	Strategic Road Network – borough roads comprised of 500km of routes which are considered to have a strategic importance in terms of network operation, including major bus routes (section A2.1)
StratMan	Strategy Manager – the component in the RTO system which will replace TfL’s current SASS (see SASS) functionality (section B2.3.8.2)
SVD	Selective Vehicle Detection – used in systems like iBus to give priority to specific types of vehicle (section B2.3.8.2)
TAG	DfT Transport Analysis Guidance (formerly WebTAG) (section A3.6.2)

TfL	Transport for London
TLRN	Transport for London Road Network – a network of nearly 580km of London’s roads which makes up 5% of the roads but carries 30% of London’s traffic and is the responsibility of TfL under the TMA (section A2.1)
TMA	Traffic Management Act 2004 – places a Network Management Duty (NMD) on all Local Traffic Authorities (LTAs) in England (section A2.1)
TMAP	TRANSYT Model Auditing Process (see MAP) (sections A3.6.1 and B2.1.5)
TNO	Organisation for Applied Scientific Research – developer of EnViVer emission modelling software (section C4.3)
TranEd	Software developed by JCT to provide an improved graphical user interface for TRANSYT versions 12 and earlier (Chapter B6)
TRANSYT	TRAffic Network StudY Tool – modelling software developed by TRL (Chapter B6)
TRL	Transport Research Laboratory (TRL Ltd) – developer of ARCADY, PICADY, SCOOT and TRANSYT (Chapter B6)
TUG	Technical University of Graz – developer of PHEM emissions modelling software (section C4.4)
UDA	User-Defined Attribute – used to expand the functionality of Vissim and Visum modelling and can consist of data from external sources or formulae using data already in the model (section B7.3.2)
UGT	Underutilised Green Time – time where there are vehicles trying to cross the stopline but they are unable to do so at full speed due to queuing or other obstructions (Appendix I)
UTC	Urban Traffic Control – the central computer system which controls a lot of the signalised junctions in London (section A2.2)
VA	Vehicle Actuation – a local method of controlling signalised junctions where timings are determined by detectors (section B2.3.8.4)
VAP	Vehicle Actuated Programming – a method used in Vissim modelling to control signal timings (section B7.4.5.1)
Vissim	Verkehr In Städten – SIMulation (meaning: Traffic In Towns – SIMulation) – modelling software developed by PTV (Chapter B7)

- Visum** Verkehr In Städten – UMlegung (meaning: Traffic In Towns – Assignment) – modelling software developed by PTV (section [A5.3.3](#))
- VMAP** Vissim Model Auditing Process (see MAP) (sections [A3.6.1](#) and [B2.1.5](#))

APPENDICES



Appendix I: Underutilised Green Time Calculation

Underutilised Green Time (UGT) is the time difference between the measured time during which high demand occurs on street (G_d), and the theoretical time that it would take for the platoon to cross the stopline under normal conditions (G_n).

$$UGT = G_d - G_n - L_t$$

Where:

G_d = Measured high demand duration during green + leaving amber period

G_n = (3600/measured saturation flow) x number of PCUs during high demand period (excluding any flare contributions)

L_t = start and end lost time

L_t can typically be assumed based on the following lane-specific behaviour:

- If high demand exists at the start of green only, then $L_t =$ one second;
- If high demand exists at the end of leaving amber only, then $L_t =$ one second;
- If high demand exists at the beginning of green and exists at the end of leaving amber, then $L_t =$ two seconds; and
- If high demand starts and/or finishes at any other time, then $L_t =$ zero seconds.

When high demand exists at the beginning of green and at the end of amber, the above assumed lost time (L_t) totals two seconds. This assumes that traffic flow takes two seconds to accelerate to saturated flow and two seconds to decelerate.

If it is the case that the start or end lost time is found to be different for a surveyed lane, then this can be incorporated if required. Any modification to the default assumed values must be outlined in an accompanying modelling report and analysed to ensure accuracy.

Without flare:

$$G_n = \left(\frac{3600}{S_{FF}} \right) \times q_d$$

With flare:

$$G_n = \left(\frac{3600}{S_{FF}} \right) \times (q_d - F)$$

Where:

q_d = Total Flow during high demand (PCU)

F = Effective Flare Utilisation (PCU)

S_{FF} = Saturation Flow (PCU/hr)

DoS Formula by means of UGT

Without flare:

$$DoS = \frac{q \times \left(\frac{3600}{T_c} \right)}{S_{FF} \times \frac{G_t - UGT + 1}{T_c}} \times 100$$

With flare:

$$DoS = \frac{q \times \left(\frac{3600}{T_c} \right)}{\left(S_{FF} \times \frac{G_t - UGT + 1}{T_c} \right) + \left(\frac{F \times 3600}{T_c} \right)} \times 100$$

Where:

q = Total Sample Flow (PCU)

G_t = Actual Total Green Time (seconds),
excluding Leaving Amber

UGT = Underutilised Green Time (seconds)

T_c = Cycle Time (seconds)

F = Effective Flare Utilisation (PCU)

S_{FF} = Saturation Flow (PCU/hr)

Appendix II: Flow Comparison (The GEH Statistic)

The GEH statistic is a standard measure of the ‘goodness of fit’ between observed and modelled flows. Unlike comparing flows using percentage difference, the GEH statistic places more emphasis on larger flows than on smaller flows.

The GEH statistic is calculated as follows:

$$GEH = \sqrt{\frac{2(M - C)^2}{M + C}}$$

Where:

M = Modelled flow

C = Counted (Observed) flow

Smaller GEH values indicate a better ‘fit’ between observed and modelled flows.

Below is a sample set of values to demonstrate the use of the GEH statistic compared with a simple percentage difference:

Table 2I: Comparative analysis contrasting GEH and percentage values

M (PCU)	C (PCU)	GEH	% Difference
10,000	9,000	10.3	10%
1,000	900	3.2	10%
100	90	1.0	10%
10,000	9,520	4.9	5%
1,000	850	4.9	18%
100	57	4.9	75%

An additional method for the comparison of flows is to plot observed versus modelled flows and carry out a correlation analysis. This method provides an indication of the goodness of fit (R correlation statistic) and clearly indicates whether the model is over or under-representing flows.

Appendix III: TRANSYT I2 Node / Link Labelling Convention

TRANSYT Labelling Convention

TI2 Nodes and Links are referenced by their user-assigned numbers, therefore it is recommended that a numbering convention is used during model development that is easily recognised and understood. This avoids confusion and allows clear assessment of model output during auditing and proposal optimisation. The numbering system described within this appendix is shown in **Figure 202**.

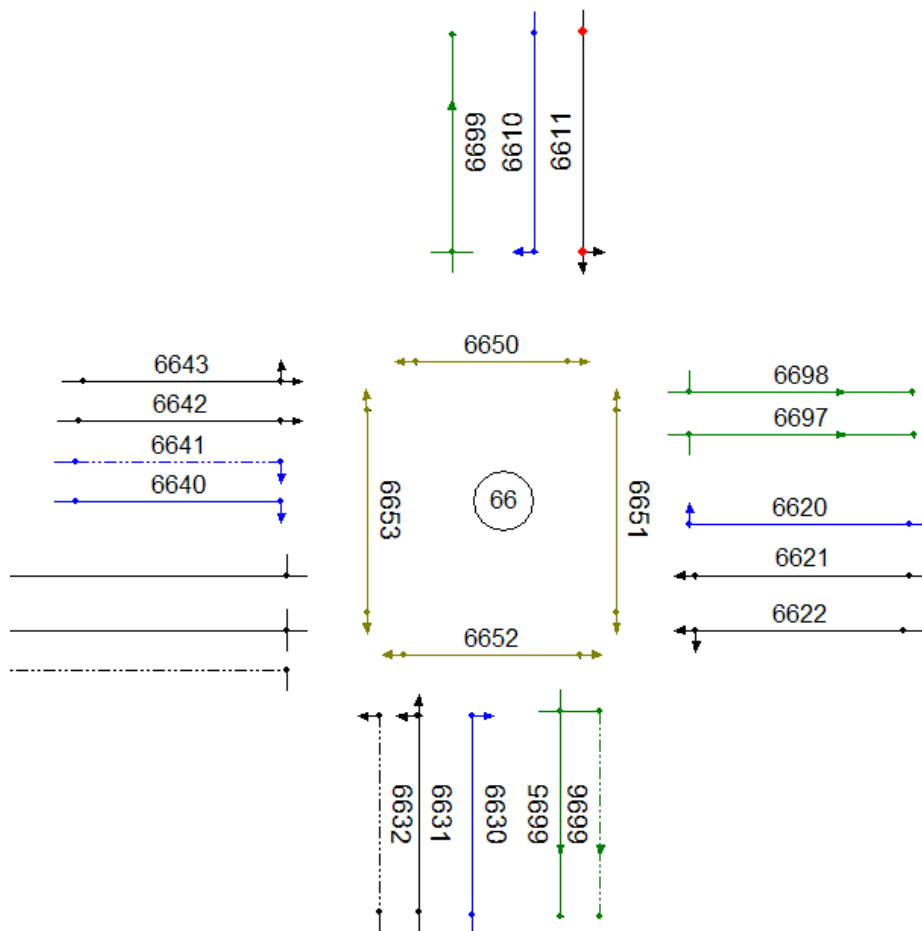

Figure 202: TRANSYT Node and Link labelling system (shown for J05/066)

T12 Numbering Limits

T12 has a maximum Link number of 32767. Therefore in the case where a Node number is 327 or higher, an alternative Link numbering convention should be used for the Node and described within the accompanying model report.

Node Numbering

For signalised intersections the TfL junction number short code should be used to label the Node without the group or region number, for example junction J05/000066 becomes J05/066 and hence TRANSYT Node 66. The borough code (in this example 05/xxx) should not be used to reference Nodes within TRANSYT. Unsignalised Nodes should be numbered using a unique number starting from ten and rising upwards in units of ten for additional Nodes.

Link Numbering

- **Traffic Links** -The traffic Link label should be constructed from the digits of the Node number (here it is 66) followed by a two digit number starting from ten. Link numbering for traffic Links should be applied in a clockwise direction, starting from an arbitrary reference direction that remains consistent throughout the model (for example southbound Links). As illustrated within **Figure 202**, Link numbers should begin with the offside Link of the reference direction, here 66I0, and increase in units of one until the nearside Link, 66II, is reached. The next junction arm in the clockwise direction is then labelled with the Node number and a two digit number starting from 20. The same numbering process then applies, from offside (6620) to nearside (6622). This is repeated for each Link moving in a clockwise direction around the Node until all approaches have been labelled. Shared minor Links should be labelled using the same technique as the associated major Link;
- **Pedestrian Links** - Pedestrian Links should be labelled in a similar manner to signalised traffic Links, following on from the last traffic Link to be labelled. For example within **Figure 202** the last traffic label was 6643, so the pedestrian Link numbering starts from 6650. Beginning at an arbitrary reference Link (such as pedestrians crossing the southbound traffic movement), the first pedestrian phase is labelled with subsequent pedestrian Links being labelled in a clockwise manner around the node, with Link numbers incremented in units of one. The next pedestrian Link would be therefore be labelled 665I, until all pedestrian Links have been labelled;

- **Exit Links** - Exit Links from the network should be labelled with the node number suffixed by two digits starting from 99. Working clockwise, starting from the same junction reference point as used for other traffic Links, the Link numbers should descend in units of one. The first exit Link in the example illustrated by **Figure 202** is therefore 6699, followed by 6698 until 6695; and
- **Priority Links** - Give-way Links use the same methodology as signalised Links, with labelling commencing with the associated node number and then a unique two digit number starting with 10, rising in increments of one on the same arm and ten for other arms.

Appendix IV: Vissim Dynamic Assignment Convergence Methods

Two steps are outlined below which may help achieve convergence when using Dynamic Assignment (DA) in Vissim.

DA Method One – Volume Increment and Cap

If congestion is preventing the model from converging, where the iterative process cannot find a solution, it may be possible to converge the model with costs representative of a lower demand level. The initial conditions are set as follows:

- Scale total volume value to 10%, store costs and paths, and create archive files;
- Set the dynamic assignment volume increment to be 10%;
- Collect the vehicle network performance indicators, matching the evaluation period; and
- Collect the Convergence file in Direct Output.

Then run the model using the following method:

- Use multirun feature and analyse the Vehicle Network Performance results for where the performance rapidly degrades to find the 'cliff-edge.' (Ideally this is as close to 100% as possible);
- Set the volume increment to 0% and use the cost and path files from the 'cliff-edge' demand volume percentage as a starting point to converge the model at the cliff-edge demand volume; and
- Monitor model convergence criteria and converge the model.

Once the model has converged, turn off 'store costs', set the volume to 100% and run the model again with the multirun feature. The model will now assign 100% of the demand, and store these volumes in the path file, based on the costs (edge travel times) calculated for the lower demand level.

Judgement must be used as to whether the costs / travel times collected at a lower demand level are representative enough to provide a basis to distribute the full demand level. In some cases it might be useful to use smaller volume increments.

DA Method Two – Partial Dynamic Assignment

If convergence criteria cannot be achieved using the first method the following technique can improve convergence stability.

For this technique, demand is assigned partially on fixed routes and partly dynamically. The fixed routes can be thought of as the proportion of travel demand that is unaware of the full set of possible routes and rat-runs in the network, and thereby uses the main signed routes. The part that dynamically assigns can be regarded as the amount of travel demand that fully understands the network and its performance and can therefore exploit any possible route that is available.

This document does not contain formal guidance on how to divide the OD matrices into the two elements, beyond the need to use sound engineering judgement. The fixed routes for the first part of the travel demand may be chosen either through local knowledge of the network or through dynamically assigning those matrices with an artificially high value for Kirchhoff's exponent. This approach should concentrate this part of the OD matrices onto a few fast routes which can then be converted to static routes once they are assured over route choice and number of available paths. The travel demand that is dynamic should be assigned over a number of iterations to show stable convergence of the assignment. be assigned over a number of iterations to show stable convergence of assignment.

Troubleshooting

Even after trying the above two methods, it may be difficult or impossible to converge or validate the Vissim model. The following tips may be useful if this is the case:

1. Monitor the model as it runs and iterates. As part of the iteration process, models can assign unrealistic volumes of vehicles on parts of the network. Where queues become long due to over-saturated stoplines, or lack of gaps, they can block other parts of the network. Model errors should be removed and the network fine-tuned to prevent the model from 'locking up', as this can prevent, or otherwise impact the rest of, the convergence process. In this case, the requirement of a stable network for convergence must be achieved without introducing unrealistic priorities or behaviour during the fine-tuning process;
2. Use a different random seed – depending on the network some will come to convergence more easily than others;
3. VA and Dynamic Signals may make it impossible to converge certain paths where small changes in traffic lead to a large impact in journey times on certain routes. It may be necessary to create VAP routines that mimic average green times and hard-code demand-dependent stages;
4. Close edges and use route closures in order to remove unrealistic / duplicate paths within the assignment;
5. Use Path pre-selection parameters to reduce the number of paths used for OD pairs;
6. Edit the path file (*.weg) directly in a text file to remove or add paths. Preserve the path list by de-selecting 'Search New Paths' in the assignment and select 'Keep paths for OD pairs with zero volume.'; and
7. Use surcharges on links / connectors to make certain links more costly. This is not routinely recommended, as the cause of vehicle delays can normally be explicitly modelled. All surcharges and costs must be justified.